

**PEPTIDE MARKERS FOR THE HIV-1 NEUTRALIZING
ANTIBODY 4E10**

by

Sondra Lynne Bahr
B. Sc., Simon Fraser University, 2000

THESIS SUBMITTED IN PARTIAL FULFILLMENT OF
THE REQUIREMENTS FOR THE DEGREE OF

MASTER OF SCIENCE

In the
Department
of
Molecular Biology and Biochemistry

© Sondra Lynne Bahr 2004

SIMON FRASER UNIVERSITY

August 2004

All rights reserved. This work may not be
reproduced in whole or in part, by photocopy
or other means, without permission of the author.

APPROVAL

Name: Sondra Lynne Bahr
Degree: Master of Science
Title of Thesis: Peptide Markers for the HIV-1 Neutralizing Antibody 4E10

Examining Committee:

Chair: **Dr. Bruce P. Brandhorst**
Professor Department of Molecular Biology and Biochemistry

Dr. Jamie K. Scott
Senior Supervisor
Professor, Department of Molecular Biology and Biochemistry

Dr. Michel R. Leroux
Supervisor
Assistant Professor, Department of Molecular Biology and Biochemistry

Dr. Mark Paetzel
Supervisor
Assistant Professor, Department of Molecular Biology and Biochemistry

Dr. Carl Lowenberger
Internal Examiner
Associate Professor, Department of Biological Sciences

Date Approved: August 18, 2004

SIMON FRASER UNIVERSITY



Partial Copyright Licence

The author, whose copyright is declared on the title page of this work, has granted to Simon Fraser University the right to lend this thesis, project or extended essay to users of the Simon Fraser University Library, and to make partial or single copies only for such users or in response to a request from the library of any other university, or other educational institution, on its own behalf or for one of its users.

The author has further agreed that permission for multiple copying of this work for scholarly purposes may be granted by either the author or the Dean of Graduate Studies.

It is understood that copying or publication of this work for financial gain shall not be allowed without the author's written permission.

The original Partial Copyright Licence attesting to these terms, and signed by this author, may be found in the original bound copy of this work, retained in the Simon Fraser University Archive.

Bennett Library
Simon Fraser University
Burnaby, BC, Canada

ABSTRACT

Monoclonal antibodies 2F5 and 4E10 neutralize a broad range of HIV-1 isolates. The epitopes for both antibodies are located in the membrane proximal region (MPR) of gp41, which is highly conserved among HIV-1 isolates. Attempts to use peptides or fusion proteins bearing the MPR as vaccines have failed, in that they produce antibodies that bind to gp41, but do not neutralize HIV-1. Thus, 2F5 and 4E10 are unique among MPR-binding antibodies in their ability to neutralize the virus.

The purpose of the work presented here is to identify peptides that are specific for 4E10, with the goal of producing a vaccine that elicits antibodies having 4E10's unique, virus-neutralizing properties. A panel of phage-displayed random peptide libraries was screened with 4E10, and two distinct peptides were identified. One is a "linear" peptide that is homologous to the native 4E10 epitope in the MPR, and the other is a "cyclic" peptide that bears no homology to the MPR. Binding of these peptides to 4E10 was optimized through the construction of two "doped" libraries that are based on each peptide's sequence. Clones isolated from both libraries bound more strongly to 4E10 than to the corresponding parental clone. Alignment of the peptide sequences from multiple clones isolated from the linear doped library revealed shared residues that are presumably important for binding. The consensus sequence they form aligns with the previously mapped 4E10 epitope in the MPR, and extends beyond that sequence. The cyclic peptide provides an alternative mechanism of binding to 4E10, and as a ligand, may reveal its unique structural features. Both the linear and cyclic peptides are specific markers for 4E10, as sera of HIV-1 infected people that bind to the 4E10 MPR epitope do not bind to either the linear or cyclic peptides. Thus, two types of peptide, which bind tightly and specifically to the neutralizing MAb 4E10, have been isolated and optimized. They have revealed the MPR epitope for 4E10 in more detail, and have served as specific serum markers for 4E10. In future, they will be tested as leads for a vaccine that targets the production of 4E10-like antibodies.

DEDICATION

To my husband Darren who has encouraged and supported me throughout my undergraduate and graduate degrees.

ACKNOWLEDGEMENTS

The work and effort of so many people have contributed to this thesis. First, I would like to thank my senior supervisor, Jamie Scott for giving me the opportunity to attend graduate school. Jamie has given me encouragement and guidance throughout my degree while also allowing me the freedom to learn from my own mistakes. I also would like to thank the members of my supervisory committee, Michel Leroux and Mark Paetzel, for their encouragement and helpful input.

I would also like to thank the members of the Scott Lab. First, I thank Alfredo Menendez who first trained me in the lab and who got this project started. Alfredo has provided invaluable advice and guidance throughout my years in the lab and during the preparation of this thesis. I also would like to thank Marinieve Montero for her helpful input and advice. I thank Sampson Wu, Heather Sarling and Keith Chow for their excellent technical support. I wish to thank Martina Mai whose help made it possible for me to complete the writing and preparation of this thesis from my new home in Toronto. I also thank Melita Irving and Nienke van Houten for their constant encouragement and who made the lab a fun place to come everyday. I would also like to thank my students Iva Kulic and Brad Jones who provided excellent help on another project during my degree. And finally, thanks to Dawn Armstrong and Joanna Chodkowska without whose help the Scott Lab would be in chaos.

TABLE OF CONTENTS

Approval	ii
Abstract	iii
Dedication	iv
Acknowledgements	v
Table of Contents	vi
List of Figures	viii
List of Tables	ix
List of Abbreviations	x
1 Introduction	1
1.1 HIV-1 and AIDS	1
1.2 Virus Entry and gp41	5
1.3 The Broadly Neutralizing Monoclonal Antibodies (MAbs)	11
1.4 Routes to Antibody Targeted Vaccine Development	19
1.5 Phage Display and Phage-Displayed Peptide Libraries	22
1.6 Thesis Work	24
2 Materials and Methods	25
2.1 Materials	25
2.2 Bacterial Strains and Culture Media	25
2.3 Cloning and DNA Sequencing	26
2.4 Biotinylation of Antibodies	27
2.5 Screening of Peptide Libraries and Selection of Clones	27
2.6 Enzyme-Linked Immunosorbent Assays (ELISA)	29
2.7 Sodium Dodecylsulfate-Polyacrylamide Gel Electrophoresis (SDS- PAGE) Analysis of the Major Coat Protein, pVIII	31
2.8 Dot Blot Analysis of Phage Clones	31
3 Results	33
3.1 Screening of Primary Libraries with 4E10 IgG	33
3.2 Doped Libraries Based on the Clones 10A.3 and E6.8 and Screening of the Libraries	41
3.2.1 Construction of the Doped Libraries	41
3.2.2 Screening of the Doped Libraries	44
3.3 Screening of Clones Picked from the Output Pools of the Doped Libraries	51

3.3.1	Clones from the 10A.3 Doped Library	52
3.3.2	Clones from the E6.8 Doped Library	55
3.3.3	Further Analysis of Optimized Clones	59
4	Discussion.....	66
4.1	4E10 Binds to a Linear Peptide with Homology to gp41	67
4.2	4E10 Binds to a Constrained Peptide with No Homology to gp41	70
4.3	The Mechanism of Neutralization of MAb 4E10 May Closely Resemble that of MAb 2F5	73
4.4	Future Studies.....	73
	References.....	76

LIST OF FIGURES

Figure 1. Schematic Representation of the Domains of gp41.....	7
Figure 2. Model of gp41-Mediated Membrane Fusion.....	10
Figure 3. SDS-PAGE Analysis of the Major Coat Protein of Phage Clones from the Screening of the Primary Libraries.....	38
Figure 4. DTT ELISA of Cysteine-Containing Clones from the Screening of the Primary Libraries.	40
Figure 5. Flow Chart of the First Screening of the Doped Libraries.	46
Figure 6. Flow Chart of the Second Screening of the Doped Libraries.....	50
Figure 7. SDS-PAGE Analysis of the Major Coat Protein of the Top Binding Clones from the Screening of the Doped Libraries.....	54
Figure 8. DTT ELISA of Clones from the Screening of the E6.8 Doped Library.	57
Figure 9. Competition ELISA of Optimized Clones from the 10A.3 Doped Library against gp41 for Binding to 4E10 Fab.....	63
Figure 10. Competition ELISA of the Optimized Clone from the 10A.3 Doped Library against gp41 for Binding to 4E10 Using a Low Antibody Concentration.....	64
Figure 11. Competition ELISA of Optimized Clones from the E6.8 Doped Library against gp41 for Binding to 4E10 Fab.	65

LIST OF TABLES

Table 1.	Primary Peptide Libraries Used in Initial Screening.....	34
Table 2.	Phage Clones Selected from Primary Libraries with 4E10.....	35
Table 3.	Analysis of Amino Acid Bias in the Doped Libraries.	42
Table 4.	Analysis of Clones from the 10A.3 and E6.8 Doped Libraries.	43
Table 5.	ELISA of Pools from the First Screening of the Doped Libraries.....	47
Table 6.	Clones from the Screening of the 10A.3 Doped Library, their Peptide Sequences and ELISA Signals.....	48
Table 7.	ELISA of Pools from the Second Screening of the Doped Libraries.	51
Table 8.	Clones from the Screening of the E6.8 Doped Library, their Peptide Sequences and ELISA Signals.....	52
Table 9.	Top Binding Clones Representing the Linear and Constrained Peptides to which 4E10 Binds.	67

LIST OF ABBREVIATIONS

ABTS	2,2'-azino-bis(3-ethylbenzthiazoline-6-sulfonic acid)
BSA	Bovine Serum Albumin
CHR	C-Heptad Repeat Region
DTT	Dithiothreitol
ELISA	Enzyme-Linked Immunosorbent Assay
Env	Envelope Glycoprotein
HIV-1	Human Immunodeficiency Virus Type 1
HRP	Horseradish Peroxidase
IPTG	isopropyl- β -D thiogalactopyranoside
LB	Luria Broth
MAB	Monoclonal Antibody
MPR	Membrane Proximal Region
NFDM	Non-Fat Dry Milk
NHR	N-Heptad Repeat Region
OD	Optical Density
PBS	Phosphate-Buffered Saline
SDS-PAGE	Sodium Dodecylsulfate-Polyacrylamide Gel Electrophoresis
TBS	Tris-Buffered Saline
Tet	Tetracycline

1 INTRODUCTION

1.1 HIV-1 and AIDS

Current estimates of the number of people infected with the Human Immunodeficiency Virus Type 1 (HIV-1) put the total at approximately 40 million adults and children worldwide, 95% of whom are living in developing countries, with approximately 5 million new cases each year (1). Therefore, HIV/AIDS truly has become a significant problem in the world.

There are three principal routes of transmission of HIV-1; all involve direct contact with bodily fluids of an infected individual such as blood, semen, vaginal fluid or breast milk (26). The majority of infections occur through sexual contact with an infected partner, the use of shared, infected needles for intravenous drug use, or from an infected mother to her child during pregnancy, the birth process, or breast-feeding. However, the risk of transmission from all of these routes can be reduced or eliminated. Education and awareness are key to the reduction of transmission in cases of unprotected sexual contact and intravenous drug use. In the cases of mother to child transfer, known as vertical transmission, risk can be reduced by the use of antiretroviral therapy and through delivery by caesarean section (42).

HIV-1 mainly infects cells of the immune system including macrophages and dendritic cells; however the primary target is CD4+ T-helper cells (73, 96). The infection and replication of HIV-1 in these cells progresses through several stages (reviewed in (32)). In the first stage, entry of HIV-1 is mediated by the envelope glycoprotein (Env),

which is composed of two subunits, the surface glycoprotein, gp120 and the transmembrane glycoprotein, gp41. Entry is initiated upon binding of gp120 to its primary cellular receptor, CD4 and a co-receptor, either CCR5 or CXCR4. It is co-receptor usage that determines the tropism of the viral strain (55, 73). Strains that utilize the CCR5 co-receptor, known as R5 strains, infect macrophages, dendritic cells and T cells, whereas strains that use the CXCR4 co-receptor, known as X4 strains, infect only T cells. Binding of gp120 to CD4 and co-receptor induces changes in gp41 that lead to fusion of the viral membrane with the target cell membrane and finally, to the entry of the viral core into the cell cytoplasm. The next stage in replication is the synthesis of two double stranded DNAs from the two copies of the viral RNA genome and their integration into the host cell genome. It is at the step of DNA synthesis that much of the variation observed in the HIV-1 population is established through the high error rate of the viral reverse transcriptase in addition to the high recombination rate between the two HIV-1 genomes (26). The double stranded DNA is then imported into the cell nucleus and integrated into the host genome as a provirus. The last stages of the viral replication cycle involve the expression of viral proteins followed by assembly and release of viral particles, and finally, maturation of infectious virus. Transcription of the viral genes occurs through the use of the transcription machinery of the cell (26). Synthesis of the envelope glycoprotein occurs in the rough endoplasmic reticulum as the precursor, gp160. It undergoes oligomerization into trimers and disulfide bond formation in the lumen of the ER and is then transported to the membrane via the secretory pathway. During transport through the Golgi, gp160 is cleaved by cellular protease into gp120 and gp41. All other viral proteins are translated in the cytosol on free ribosomes (26). After

synthesis of the viral proteins, assembly and release of the virus occurs. In T cells, the Gag precursor protein directs the assembly of the internal components of the virus and release via budding from the host cell plasma membrane (2, 32). However, it has recently been shown that in macrophages, HIV-1 accumulates in cellular compartments known as multivesicular bodies and exits the cell as exosomes (2, 62, 63). It is unclear why this difference exists but it is possible that the release of viral particles from macrophages via exocytosis may aid in the transfer of virus to T cells. If the release of HIV-1 through exocytosis occurs in a controlled manner upon activation of the cell, the release of HIV-1 could be targeted to T cell rich environments (2). However, it has not been determined if the release of HIV-1 from macrophages is constitutive or regulated (2). Finally, after release of the virions, viral protease cleaves the Gag and GagPol precursor proteins leading to structural rearrangements and maturation of the virus to its infectious form (26, 32).

The pathogenesis of HIV-1 is characterized by three distinct stages: seroconversion, latency, and AIDS (reviewed in (66)). Upon initial infection, an individual usually experiences only mild, flu-like symptoms, if any at all. There is a spike in detectable levels of viral particles in the blood, known as viral load, coinciding with a drop in the number of CD4+ T cells. This phase usually lasts a short time of a matter of weeks to a few months, and is followed by the second stage, termed clinical latency. The latency period can last from a few years up to 10-15 years or longer. During the latency period, an immune response is initiated which results in a rise of CD4+ T cell counts to a stable level and a decrease in viral load despite continual viral replication (26). Over time, there is a gradual decline in the CD4+ T cell count along

with an increased incidence of opportunistic infections. This eventually signals the beginning of the third and final stage, AIDS. At this stage, CD4+ T cell counts drop to extremely low levels and viral load increases in a dramatic spike. This stage is also usually characterized by an abundance of opportunistic infections, and it is usually these infections rather than HIV-1 itself that lead to death (26).

Because HIV-1 is such a devastating pathogen, there have been many attempts to develop therapeutics against it. This includes treatments such as Highly Active Anti-Retroviral Therapy (HAART) and the peptide inhibitor, T20 (pentafuside) (23). Although such treatments have been effective in reducing viral load in patients (26), they are not a cure and may induce secondary complications including the development of resistant viral strains (26). It is for this reason that treatments alone for HIV-1 will never be completely successful and thus emphasizes the need for preventative measures.

A sterilizing vaccine against HIV-1 is highly desirable. However, there are a number of criteria it would need to meet in order to be useful (61). It would need to be effective against a wide range of isolates and provide protection from isolates in all of the different clades. This is a particularly challenging requirement as HIV-1 has spread so rapidly and mutates at a high frequency. However, several sites that are important for the infection and replication cycle of the virus are highly conserved, and are being studied as potential targets for vaccines (100). Past studies have shown that to be most effective, a vaccine should initiate both cellular and humoral immunity (100). Because of the small number of broadly neutralizing antibodies to HIV-1 identified to date, there has been much debate on this subject and there have been varying trends in the past concerning the importance of antibody mediated immunity in protecting against HIV-1 infection.

However, most recent studies indicate that antibodies can provide sterilizing protection (18, 31, 47-49), and an effective vaccine should incorporate both cellular- and antibody-mediated immunity (61). Finally, a vaccine for HIV-1 should be cost effective and easy to transport and dispense to be useful to developing countries, where it is needed most (61).

1.2 Virus Entry and gp41

The envelope protein of HIV-1 is a desirable target for vaccine development because of its important role in infection, and, in particular, viral entry. It is for this reason that much work has been done on the structure and function of this important viral component. The envelope glycoprotein is present in the membrane as a trimer of dimers (74). That is, each envelope spike is made up of three gp120-gp41 dimers. gp120 is the extracellular component of the infectious spike, and is non-covalently linked to gp41, the transmembrane protein. Together, gp120 and gp41 make up the complete envelope protein and each plays its own part in the entry process.

The gp120 protein of Env is heavily glycosylated, with carbohydrate making up a large portion of its molecular weight. The most heavily glycosylated region of gp120 is the outer portion of the trimer, exposed to the extracellular environment (98). Other portions of gp120 are not readily exposed to the environment, as they are masked by inter-molecular interactions with other gp120 molecules of the trimer and with gp41. The gp120 protein initiates the virus entry process by binding to its primary receptor, CD4 which induces the binding site (the CD4i site) for a co-receptor molecule, either CCR5 or CXCR4 (26, 33, 98). Co-receptor binding induces further conformational changes in gp120 that lead to its dissociation from gp41 (33). Upon dissociation of gp120, gp41

then undergoes its own conformational changes that ultimately lead to membrane fusion, pore formation and virus entry.

The gp41 protein of HIV-1 is the transmembrane component of Env. It contains three very distinct domains: the extracellular domain, the transmembrane domain and a short intracellular domain (Figure 1). The extracellular domain can itself be broken up into several different regions (39). The N-terminal portion of gp41 is made up of the fusion peptide, which inserts into the target cell membrane and helps to bring this membrane in close contact with the viral membrane during the fusion process (33). C-terminal to the fusion peptide, are two 4,3 hydrophobic repeat regions, the N-heptad repeat region (NHR) and the C-heptad repeat region (CHR) (17). These regions are separated by a disulfide-bonded loop that contains the immunodominant region known as the Cluster I epitope (39). C-terminal to the CHR is the membrane proximal region (MPR) of gp41. This region contains the epitopes for the two broadly neutralizing antibodies against gp41 (76, 104), and thus has become of particular interest for vaccine development. C-terminal to the MPR is the transmembrane domain, and finally, the intracellular domain. The identification of antibodies directed against the intracellular domain has inspired some debate regarding the presence of a second transmembrane region and the possibility that part of this domain is exposed on the cell surface (19, 20).

Figure 1. Schematic Representation of the Domains of gp41.

The location of the putative functional domains of the gp41 protein are shown. The sequence of the membrane proximal region is indicated with the 2F5 and 4E10 epitopes shown in bold, respectively. FP, Fusion Peptide, NHR, H-heptad repeat region, CHR, C-heptad repeat region, TM, transmembrane domain.

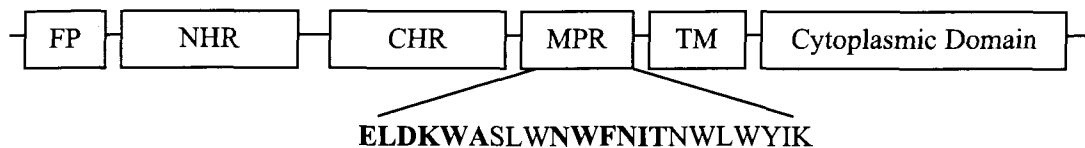

The structure of the entire ectodomain of gp41 has not yet been resolved, however, structures have been determined for versions including the heptad repeat regions and for the MPR. Three groups have independently resolved the structure of what is believed to be the fusion active state of the core of the extracellular domain of gp41, which includes the NHR and CHR. These structures were obtained using truncated regions of the ectodomain (13, 16, 92, 97). The two heptad repeat regions fold together to form a trimeric coiled coil. Three NHR pack closely together in a parallel manner forming a three helix bundle, and the three CHR pack in an anti-parallel orientation into hydrophobic grooves between the NHRs. The resulting six-helix bundle structure is extremely stable and is energetically favoured (92). The MPR of gp41 is also of great interest and importance due to the fact that it contains the epitopes of the broadly neutralizing antibodies 2F5 and 4E10. This region of gp41 is rich in Trp residues and has been shown to form a helical structure at the membrane interface (85). Although it has been shown that this region is essential to the fusion process (15, 38, 80), the structural role it takes in fusion, pore formation and viral entry is unclear. However, there are studies to suggest that it acts to perturb membranes (89, 90), and thus may aid in the mixing of the viral and cellular membranes during the fusion process.

Current models of membrane fusion involving gp41 closely resemble those of the highly characterized influenza virus haemagglutinin (Figure 2) (reviewed in (33), (22) and (29)). It is believed that gp41 is present on the surface of infectious HIV-1 as a component of envelope in its native pre-fusogenic state. This state appears to be a metastable intermediate that is poised for release (29). Upon binding of gp120 to its cellular receptor and subsequent dissociation from gp41, gp41 undergoes a conformational change that allows the fusion peptide to interact with the plasma membrane of the target cell (29, 33), and to form a new conformation known as the pre-hairpin intermediate (17). In this structure, gp41 is present in an extended state with the fusion peptide inserted in the target cell membrane, and the NHR and CHR extended and not in contact with one another. A subsequent conformational change then occurs resulting in the formation of the fusion active conformation, in which the two heptad repeat regions come together to form a stable, anti-parallel, six-helix bundle (29, 33). This brings the cellular and viral membranes into close contact with one another. It had long been assumed that the six-helix bundle was fully formed before membrane fusion and that some unknown mechanism brought about fusion after this step, however, most recent evidence suggests that this is not the case. Using sub-optimum temperatures to arrest the fusion process at the pre-bundle stage, Melikyan *et al.* showed that treating the temperature arrested intermediate with an inhibitor of membrane merger prevented bundle formation (51). Thus, they concluded that because the six-helix bundle required membrane merger to form, the bundle itself could not cause the merger. This was further supported by the work of Markosyan *et al.* who showed that not only is six-helix bundle formation dependant on membrane merger, but that some bundle formation actually

occurs after fusion pore formation itself, and thus that the bundle may act in stabilizing the pore against collapse (46). Further, there is evidence that the immunodominant Cluster I loop present between the NHR and CHR plays a role in preventing pore collapse by stabilizing the six-helix bundle (72).

The importance of the MPR in fusion and infection, and thus its desirability as a target for therapeutics and vaccines against HIV-1 has been demonstrated by the success of the fusion inhibitor T20. T20 is a peptide inhibitor derived from the CHR sequence that interferes with the development of the six-helix bundle formation of gp41. T20 is believed to act by binding to the NHR during the formation of the coiled-coil, thereby blocking the CHR from interacting with the NRH, and consequently, blocking the formation of the fusion active conformation of gp41 (3). The positive results found with the T20 peptide inhibitor (3) show the importance of this step in fusion, and thus infection, giving support to the notion that targeting this process is desirable in the development of a vaccine.

Figure 2. Model of gp41-Mediated Membrane Fusion.

A schematic model for gp41-mediated membrane fusion. The native envelope trimer on the surface of the virion undergoes a conformational change after gp120 binding to CD4 and co-receptor. Dissociation of gp120 from gp41 is followed by formation of the pre-hairpin intermediate and insertion of the fusion peptide in the target cell membrane. The fusion active, stable six-helix bundle conformation is then formed along with pore formation and expansion. Finally, the putative post-fusion conformation is shown. NHR, H-Heptad Repeat Region, CHR, C-Heptad Repeat Region.

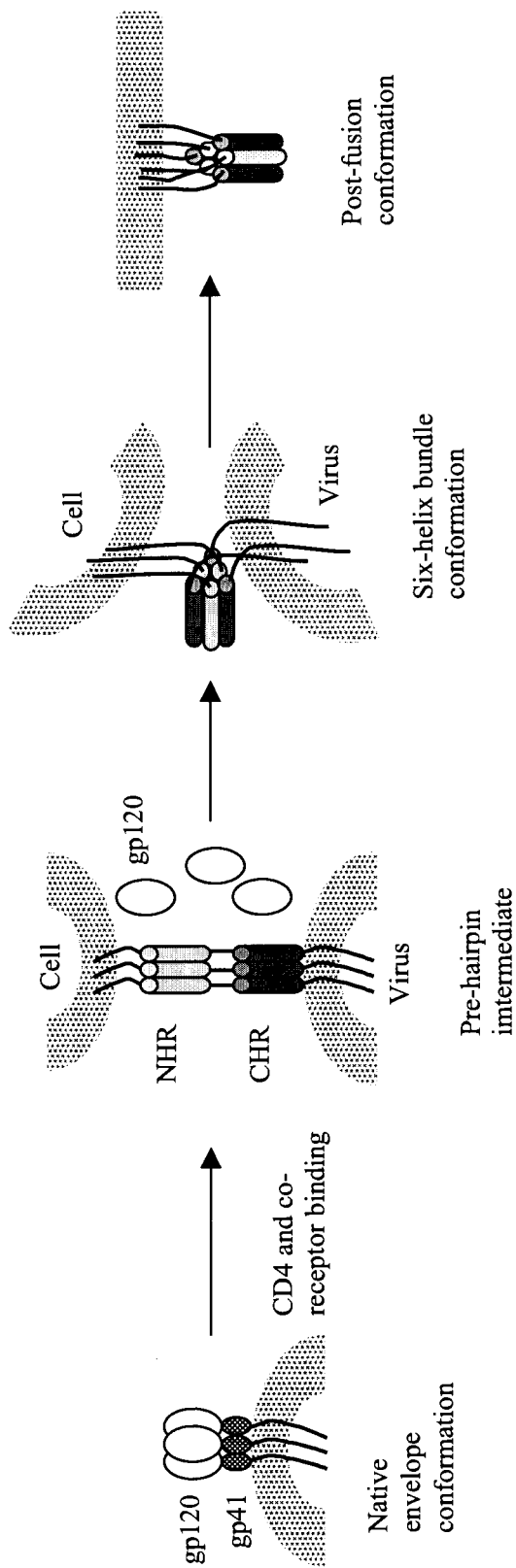

1.3 The Broadly Neutralizing Monoclonal Antibodies (MAbs)

Patients infected with HIV-1 have a robust antibody response to HIV-1; however, most of the antibodies produced are not neutralizing or are strain-specific and not broadly neutralizing (77). This lack of neutralizing antibodies led many researchers to conclude that antibodies are not important in the control and protection from HIV-1, and therefore they concentrated mainly on the cellular immune response in vaccine development. But, there have been a handful of broadly neutralizing antibodies identified that also protect against HIV-1 or SHIV infection *in vivo*, supporting the theory that antibody mediated protection from HIV-1 is possible.

Most HIV-1 neutralizing antibodies identified only neutralize type-specific or T-cell line adapted strains of the virus, which have been shown to be more susceptible to neutralization than primary isolates that have not been repeatedly passaged through cultured T cells (77). However, there are several broadly neutralizing MAbs that have been identified to date (11, 57, 104). These antibodies have been defined as broadly neutralizing because they are able to neutralize a broad range of isolates from a number of different clades. Four of these broadly neutralizing MAbs, IgG1b12 (b12), 2G12, X5 and 447-52D, are directed against gp120 and two, 2F5 and 4E10 are directed against gp41.

The gp120-binding antibodies recognize a diverse set of epitopes and all have unusual characteristics. The b12 and X5 antibodies were identified from phage-displayed Fab libraries created from the bone marrow of HIV-1 infected individuals (4, 57). b12

recognizes an epitope that overlaps the CD4 binding site of gp120 (78). Although many antibodies have been identified that bind to epitopes overlapping the CD4 binding site, b12 is the only one with broad neutralizing activity. Crystallographic analysis of the b12 structure by Saphire *et al.* revealed that the third complementarity determining region of the heavy chain (CDR H3) is very long, and protrudes from the antigen binding region (82). Further, this work suggested that the unusually long CDR H3 can penetrate the recessed cavity of the CD4 binding site, which may account for its unique neutralizing characteristics. X5 is directed against an epitope that is exposed after binding of gp120 to CD4 and that is very close to, but does not overlap, the CCR5 binding site (27, 57). X5 also has a long CDR H3 (27), and is unusual in that it is capable of neutralizing primary isolates only as a Fab or single-chain Fv (not as an IgG), most likely due to steric hindrance at this site after binding of gp120 to CD4 (44).

The MAb 2G12 was identified from a panel of human hybridoma cells derived from HIV-1 infected individuals (11). Like b12, it is an unusual antibody. The 2G12 epitope on gp120 is composed entirely of mannose glycans (81, 83). An unusual aspect of 2G12 has been revealed by analysis of its structure. 2G12 has swapped heavy chain variable region domains such that they cross over between C_{H1} and V_H (14). This results in the pairing of the heavy chain variable region with the opposite light chain variable region and a departure from the usual “Y” shape of an IgG molecule to a more extended “T” configuration. This creates a large antibody paratope comprising two V_HV_L interfaces separated by a V_HV_H interface. All three sites bind mannose residues, allowing this unusual antibody to bind the end of one or more branched mannose oligomers.

The final broadly neutralizing antibody against gp120, 447-52D, was also identified from a hybridoma cell line derived from an HIV-1 infected individual (35), and recognizes an epitope that includes the conserved GPGR motif on the hypervariable, V3 loop of gp120 (87). The V3 loop is important for co-receptor binding and contributes to viral tropism (32). Because 447-52D neutralizes both R4 and X5 strains, it is the most effective of all the anti-V3 neutralizing antibodies (87). Like b12 and X5, 447-52D was shown by crystallographic analysis to have a long CDR H3 that binds much of the length of the V3 loop (87).

Unlike the gp120-binding antibodies, the two anti-gp41 neutralizing antibodies recognize apparently linear epitopes that are closely situated in the MPR of gp41. The potent and broad neutralizing abilities of 2F5 and 4E10 have emphasized the importance of this region in the fusion process, and thus have drawn attention to this region as a possible target for vaccine development.

2F5 has long been acknowledged as possibly the most important neutralizing antibody against HIV-1, and thus, has been extensively studied. Soon after its discovery, 2F5 was shown to recognize the linear sequence ELDKWA present on the MPR of gp41, residues 662-667 (gp160 numbering of isolate HxB2) (24, 59). This epitope is highly conserved among isolates, and as such has been established as a desirable target for antibody-directed vaccine development. While numerous attempts to elicit neutralizing antibodies with various representations of the ELDKWA sequence produce a robust antibody response, immune sera so far have not been capable of neutralizing primary isolates (21, 30, 50, 58). It is likely that this sequence is not sufficient to induce neutralizing antibodies. In order to further understand the full nature of the 2F5 epitope

and the requirements for maximal binding by 2F5, many studies have been conducted on this region of gp41. The hexameric epitope for 2F5 was initially determined using overlapping peptide fragments of gp41 fused to GST (59), however more recent studies suggest that an extended sequence is required for optimal binding (5, 70, 93). In addition, the structure of 2F5 bound to the ELDKWA sequence by Pai *et al.* (65) demonstrated a β -turn configuration of the core DKW motif when bound, supporting the notion that structure plays a role in 2F5 binding. McGaughey and colleagues showed that peptides containing an extended sequence encompassing the 2F5 epitope only showed maximum binding to 2F5 when they were constrained by a side-chain to side-chain lactam bridge (50), and Joyce *et al.* showed that increasing the alpha-helicity in the HIV-1 inhibitory peptide DP178, increased the binding affinity of 2F5 (41). Menendez *et al.* have further defined the binding characteristics of 2F5. This group generated two phage-displayed peptide libraries having 12 randomized amino acids either N-terminal or C-terminal to the DKW core epitope, and screened them with 2F5. Three peptides from the C-terminal library were identified as having similar high affinity despite a lack of homology to each other. Additionally, through Ala substitution and deletion mutation analyses, it was demonstrated that each of these peptides bound 2F5 by a different mechanism, and thus it was concluded that 2F5 contains a second, multispecific region within its paratope.

Like the other broadly neutralizing antibodies, b12, X5 and 447-52D, 2F5 has been shown to have a long CDR H3 region (103). While the crystal structure of 2F5 bound to the ELDKWA sequence shows that only the base of this long H3 is in contact with the peptide (65), mutagenesis studies have shown that mutations to a Trp residue at

the apex of the H3 loop abrogate binding to gp41 (103). Further, this mutation had a negative effect on the neutralizing ability of 2F5. Recent studies by Ofek and colleagues (64) have further demonstrated the unusual characteristics of 2F5. This group showed by crystallographic analysis that only one face of the 2F5 epitope is actually in contact with the antibody, with the C-terminal region following DKW making extensive contacts with the H3 of 2F5. This structure suggests that the other face of the 2F5 epitope may be in contact with membrane, and that the apex of CDR H3 of 2F5 provides a flat, hydrophobic surface that could contact both the MPR and membrane when bound to gp41. They further support this notion by showing that binding to 2F5 is increased when the MPR is in contact with membrane. Additionally, Grundner *et al.* showed that affinity of 2F5 for mutant gp160 glycoproteins presented as trimers on solid phase proteoliposomes with membrane was up to ten times greater than for the mutant gp160 on beads without membrane (37).

An understanding of the mechanism of neutralization of 2F5 is also desirable. Several studies have been carried out to determine the conformational state of the gp41 MPR against which 2F5 is active (7, 28, 36). Binley and colleagues have developed a mutant HIV-1 envelope protein with a disulfide-bridge that links gp120 to gp41, which has enabled them to halt fusion at an intermediate state, and allow fusion to proceed upon addition of a reducing agent (7, 8). With this, they analyzed the timing of the neutralizing activity of various anti-envelope antibodies, including 2F5. This study showed 2F5 to be most active against the pre-hairpin intermediate present after initial attachment of the viral envelope protein to its cellular receptor, and not at all active against the fusion active, six-helix bundle conformation, indicating that it may act to

inhibit bundle formation, which mediates membrane fusion. de Rosny *et al.* also found that 2F5 binds the gp41 pre-hairpin intermediate, but not the six-helix bundle configuration (28), confirming the data of Binley *et al.* However, they also showed that incubation of 2F5 with Env-expressing cells did not prevent binding of a six-helix bundle-specific MAb to receptor-activated gp41. This suggests that 2F5 does not prevent six-helix bundle formation, and neutralizes HIV-1 by interfering with a later step in the fusion process, such as membrane fusion or pore formation. However, it is also possible that 2F5 is extremely efficient at neutralizing HIV-1, and only needs to bind to a few of the gp41 proteins, preventing these from forming six-helix bundles.

Although 4E10 was first identified ten years ago, it has only recently been thought of as an important anti-HIV-1 antibody (104) and has thus re-emerged as an exciting focus of HIV-1 research. Like 2G12 and 2F5, Katinger and colleagues identified 4E10 from a panel of human hybridoma cells produced by electrofusion of peripheral blood lymphocytes from HIV-1 infected individuals (11). Hybridoma cells were screened for antibody production, secreted antibodies were tested for binding and neutralization of HIV-1, and epitope mapping was carried out. In this study, the epitope for 4E10 was tentatively mapped to the sequence AEGRDRV, corresponding to residues 824-830 of gp160 (numbering of isolate BH10); this sequence is located on the putative intracellular domain of gp41, and thus is probably not exposed on the viral surface. However, it was noted that this antibody also showed much cross-reactivity with MHC class II protein as well as with other HIV-1 peptides by ELISA, and it was thus concluded that the binding properties of this antibody required further analyses for clarification.

Not much interest was taken in 4E10 for a number of years. Although it appeared to have some neutralizing activity, it was suspected that this was not real because it is unlikely that an antibody could be effective at neutralizing the virus if its epitope is not exposed on the surface of intact virus. However, this changed in 2001 when Zwick *et al.* published work showing that 4E10 recognizes an epitope that is in the MPR of gp41 and would be exposed on the intact virus, thus making it a prime target for a neutralizing antibody (104). This group tested the binding of 4E10 to a series of overlapping peptides from gp41 as well as to a number of other proteins. They observed strong binding to one peptide of the MN isolate from the MPR of gp41, but only weak binding to the peptide corresponding to the previously mapped epitope for 4E10. They also observed non-specific binding to a variety of other antigens at higher concentrations, and thus concluded that it was these characteristics that led to the original mapping of the epitope to the intracellular region. This group further supported their findings through the screening of a gene fragment library of gp160 expressed on the minor coat protein, pIII, of filamentous phage. Several clones identified from the screening of this library with 4E10 showed a strong alignment that represented the same region of the protein as the MN peptide, and further defined the epitope as the minimum binding sequence, NWFNIT (sequence from the HxB2 isolate).

At the same time, the group of Katinger *et al.*, which originally identified 4E10, published experiments remapping the 4E10 epitope. They independently identified the same region and sequence as the epitope for 4E10 (88). This group also carried out *in vitro* neutralizing assays to estimate the neutralizing potential of this antibody. They found that 4E10 neutralized several primary isolates of HIV-1 from diverse sub-types

including B, C and E. These findings of broad neutralization renewed interest in 4E10 and led several other groups to study the neutralizing ability of 4E10 in comparison to the other broadly neutralizing antibodies (43, 99, 107). So far, 4E10 seems to be by far the broadest neutralizer, if not always the most potent. Binley *et al.* recently presented a poster at the 2004 Keystone Symposia on Molecular Mechanisms of HIV Pathogenesis, showing the results of their study of five broadly neutralizing antibodies, in addition to several others antibodies (6). Their findings show that while some of the other antibodies neutralize several isolates at lower concentrations, 4E10 was the only one that neutralized, at least partially, every isolate tested. It is also important to note that this study is thus far the most extensive one done, in terms of the number of isolates tested, as well as the fact that the panel they tested contained representative isolates from all of the currently recognized sub-types of HIV-1.

In addition to studies on the *in vitro* ability of 4E10 to neutralize virus, there have been several studies on the protection by 4E10 *in vivo*. Passive transfer studies of 4E10 in combination with other neutralizing antibodies, including 2F5, 2G12 and b12, have shown protection of macaques from oral challenge with pathogenic SHIV strains, which are chimeric viruses having an SIV-derived genome, except for an HIV envelope gene (31, 79). Although 4E10 has not yet been tested on its own in passive transfer studies, *in vitro* neutralization assays have shown neutralization synergy among the antibodies in combination, suggesting that the contribution of 4E10 is significant. Additionally, the fact that the broadly neutralizing antibodies have been shown to provide protection from challenge with HIV-1 shows that antibody-mediated protection from HIV-1 is a desirable goal in vaccine development.

1.4 Routes to Antibody Targeted Vaccine Development

Traditional methods of vaccine development are not necessarily viable in the case of HIV-1. One of the first approaches for an HIV-1 vaccine attempted was that of a live attenuated virus. Although thought promising at first, this approach has raised too many questions regarding its safety for use in humans (45). For example, a live SIV vaccine, attenuated by deletion of the *nef* gene, was shown to produce disease in neonatal macaques and in long-term infected adults (45, 61). Another common approach for vaccine development is the use of recombinant viral proteins. Attempts to use recombinant forms of gp120 have proven safe for use in humans; however, antibodies induced by these vaccines do not neutralize primary isolates of HIV-1 (60). Researchers have instead turned to other strategies such as viral vector vaccines or DNA vaccines. While these strategies have shown promise in some animal models, there is no evidence that they will be any more effective in humans than the recombinant protein vaccines (45, 60).

HIV-1 has evolved many mechanisms for evading the immune system, making the job of researchers more challenging (40). One such mechanism involves the genetic diversity of HIV-1. Because it mutates very rapidly, there are many regions on HIV-1 proteins that are not highly conserved among isolates. An example of this is the third hypervariable loop (V3) of the gp120 component of envelope. Although V3 is important for co-receptor binding, it has considerable sequence variation, with the exception of a small region at its apex bearing a GPGR or GPGQ turn (87). The V3 loop is highly immunogenic, but because of its high variability, most antibodies directed against it demonstrate only type specific neutralizing properties (100). The broadly neutralizing

antibody 447-52D is an exception and has been shown to neutralize several primary isolates; however, because it requires a GPGR sequence for binding, it cannot neutralize the majority of isolates from non-clade B subtypes (6, 12). Another strategy employed by HIV-1 is to make sites related to important functions of proteins poorly accessible to antibodies or only transiently accessible (61). For example, an important part of the CD4 binding site on gp120 is present in a recessed cavity. While there are many antibodies against the CD4 binding site on recombinant gp160 capable of blocking CD4 binding, only the highly unusual b12 antibody has neutralizing ability (i.e., it alone can bind gp120 on the infectious trimeric spike). It is unclear why this is the case, but it may be due to the very long CDR H3 of b12 that is able to reach into the cavity of the CD4 binding site (82). Additionally, the conformational changes that occur in both gp120 and gp41 during the entry process likely reveal transient epitopes that are important to this process but exposed for only short periods. Glycosylation of gp120 is another way in which HIV-1 may “hide” from the immune system. The heavy glycosylation masks the protein making it inaccessible to antibody, and because carbohydrate is much less immunogenic than protein, there is not a very good immune response against this part of the protein (61, 71, 95). The only exception, of course, is the one broadly neutralizing antibody 2G12; however, this is a very unusual antibody, as noted above. There are also many highly immunogenic sites on gp120 that are not exposed on the exterior of the virus on intact, infectious envelope spike since these portions of gp120 are in contact with other gp120 molecules as well as with gp41 in the trimeric envelope spike. These sites, however, are readily available for antibody binding on monomeric gp120 that has been “sloughed off” the virus (61). While there are now attempts to engineer better

immunogens using various strategies such as generating a representation of the native viral spike protein or stable intermediates of the fusion process, so far none have proven effective (12).

Alternatively, some researches have devised a new strategy that has been described as “immunofocusing” (67). In this strategy, the researcher starts with a neutralizing antibody and works back towards the antigen, which is the opposite of more traditional methods in which one starts with the antigen and then works towards the desired immune response. Instead, analyses of the antibody interaction with its epitope help guide the engineering of an antigen that will be capable of eliciting the desired antibodies. In the case of HIV-1, there are several broadly neutralizing antibodies identified to date that one could start with. Already, work is in progress to develop a gp120 antigen that will induce the production of b12 or b12 like antibodies. Pantophlet *et al.* have developed a recombinant gp120 protein with amino acid replacements of several residues on the outer edge of the CD4 binding site cavity, as well as the addition of N-glycosylation signal sequences to mask other epitopes (68, 69). Together, these mutations significantly reduced the binding of several weakly or non-neutralizing antibodies, including anti-CD4 binding site antibodies, and CD4 itself, while preserving the binding of b12. It is hoped that this will reduce the production of these non-neutralizing antibodies and focus the response on the b12 epitope. However, it is not known what other effects this engineering may have, given that the CD4 binding site has been changed from its native structure to bind a single rare neutralizing antibody (67).

Another approach to the immunofocusing strategy is to develop novel peptide-based immunogens to help focus the immune response. Using a prime-boost

immunization protocol may enhance this further. For example, to identify possible peptide vaccine leads, a panel of phage-displayed random peptide libraries was screened with the b12 antibody and the tight binding peptide, B2.1 was identified (101). Therefore, a priming immunization might be carried out with whole gp120, with subsequent immunization using the B2.1 peptide. This should act to enhance production of b12-like antibodies produced in the priming immunization. Additionally, peptides can be used to gain a better understanding of the epitope and the antibody. Menendez *et al.* demonstrated this in the characterization of the multi-specificity of the 2F5 paratope. Structural studies of these peptides bound to 2F5 may further elucidate the binding characteristics of 2F5, which may in turn aid the development of an immunogen that will target its production.

Besides the use of peptides to understand antibody-epitope interactions, or for use in antibody-targeted vaccines, there is an additional reason why peptides specific for a particular antibody are desirable. Justification for an “immunofocusing” vaccine based on a particular anti-HIV-1 antibody, requires that HIV-1 infected individuals can in fact produce the targeted antibody, or ones like it. Peptides could thus be used as specific markers for these particular antibodies. This is important considering the high frequency of non-neutralizing antibodies elicited during HIV-1 infection (12).

1.5 Phage Display and Phage-Displayed Peptide Libraries

Phage-display technology is an extremely useful tool for identifying ligands for enzymes, receptors and especially antibodies. Small proteins such as peptides or antibody fragments are fused to the capsid proteins of bacteriophage and thus “displayed” on their surface. The filamentous bacteriophage are small, viral particles that infect

gram-negative bacteria through their conjugative pili (54). They contain a circular, single stranded DNA genome that is approximately 6400bp in length and about 2700 copies of the major coat protein, pVIII, package this DNA (94). Filamentous phage also contain several other minor coat proteins, including the pIII protein, which is present in three to five copies at one end of the phage and facilitates infection by binding to the bacterial F pilus (54).

Phage can be engineered to display small proteins or peptides on one of the coat proteins. Often larger protein fragments, such as Fab, are displayed on the N-terminus of the minor coat protein pIII. Smaller molecules, such as peptides, can be displayed on the N-terminus of the major coat protein, pVIII. This allows for a higher copy number of the recombinant protein, and thus a greater level of display.

The technology of phage display has allowed the creation of libraries of phage-displayed molecules such as peptides. It is possible to make libraries of random peptides displayed on the pVIII protein containing up to 10^{10} different possible clones (9, 86). This facilitates the identification of peptide binding partners for a variety of molecules, such as enzymes or antibodies. Such libraries can be “screened” using the protein of interest in a process known as panning. In this technique, successive rounds of affinity purification are carried out whereby phage, bearing peptides that can bind to the target protein, are isolated from the library by immobilized target (or target in solution and then the complexes of target and phage are captured). Unbound phage particles are then washed away leaving only those that bind, which are then amplified in bacteria. The new pool of amplified phage is enriched for phage bearing ligand peptides, and these can be further enriched by subsequent rounds of panning. Panning is carried out for three or

four rounds, depending on the target and the phage library. Through these rounds of affinity selection, phage that bind to the target will be enriched and are identified from the pools when picked as clones. Thus, phage display is a powerful tool for identifying specific binding partners from pools of millions to billions of different possible peptides.

1.6 Thesis Work

This thesis discusses work identifying and optimizing two peptides that bind to the broadly neutralizing anti-HIV-1 antibody, 4E10. These peptides were isolated through the screening of several random phage-displayed peptide libraries, and were subsequently optimized through the construction of two “doped” libraries based on the sequence of the parental peptides.

The two peptides identified represent distinct binding partners for the MAb 4E10. One peptide is linear and homologous to the native epitope for 4E10 on the MPR of gp41. The other peptide bears no homology to the epitope and is constrained by a disulfide bridge. These two peptides have helped gain insight into the 4E10 MAb. They have helped confirm the epitope identified for 4E10 as well as suggesting a possible extension of this epitope. In addition, the identification of the cyclic peptide has provided a marker that is specific to 4E10, and should serve to identify the presence of 4E10 or 4E10-like antibodies in the sera of HIV-1 infected individuals. It should also have the ability to distinguish these antibodies from others that bind to the 4E10 epitope but do not neutralize HIV-1.

2 MATERIALS AND METHODS

2.1 Materials

Eleven phage-displayed random peptide libraries were provided by J. K. Scott (9). The four “Cys” libraries were a gift from G. P. Smith (University of Missouri, Columbia, MO). 4E10 IgG was kindly provided by H. Katinger (University of Agricultural Sciences, Vienna, Austria) and 4E10 Fab by R. Stanfield (The Scripps Research Institute, La Jolla, CA). Horseradish peroxidase (HRP)-conjugated, goat anti-human IgG (Fab-specific), HRP-conjugated neutravidin, HRP-conjugated protein A/G and sulfo-NHS-LC biotin were purchased from Pierce (Rockford, IL). Dialyzed bovine serum albumin (BSA), dithiothreitol (DTT), tetracycline (Tet) and 2, 2'-azino-bis(3-ethylbenzthiazoline-6-sulfonic acid) (ABTS) were purchased from Sigma (St. Louis, MO). Recombinant gp41 was purchased from Cedarlane Laboratories, Ltd. (Hornby, ON). Oligonucleotides were synthesized at Simon Fraser University using an ABI 392 synthesizer by the two column method of Glaser *et al.* (34) and then gel purified.

2.2 Bacterial Strains and Culture Media

Phage production was carried out using the procedures of Bonnycastle *et al.* (9). *E. coli* strain K91 was used for phage amplification and the electrocompetent strain MC1061 was used for the production of the doped phage libraries. The media NZY supplemented with 15µg/ml Tet and the inducer 1mM isopropyl-β-D-thiogalactopyranoside (IPTG) was used for phage production.

2.3 Cloning and DNA Sequencing

The construction of the 10A.3 and E6.8 doped libraries was carried out using the procedures described by Bonnycastle *et al.* (10). Briefly, circular, single-stranded phage DNA of the phage vector f88.4 was linearized using a HindIII oligo annealed to the phage DNA and the restriction endonuclease, HindIII (Invitrogen, Carlsbad, CA). Library oligos were annealed to the linearized DNA and extended using Klenow fragment (Invitrogen) and Vent (New England Biolabs, Beverly, MA) DNA polymerases in a Hybaid PCR Express machine (Thermo Electron, Woburn, MA). Enzymes and excess dNTPs were removed from the reaction using phenol/chloroform and a QIAquick PCR Purification Kit (Qiagen, Valencia, CA). Double stranded DNA was then digested with Pst I (New England Biolabs) and purified as described above. Pst I digested DNA was then ligated overnight to form covalently closed, circular DNA. Ligation reactions were concentrated and desalted using a 10K Ultrafree®-MC Centrifugal Filter Device (Millipore, Billerica, MA) and then used to transform *E. coli* strain MC1061 electrocompetent cells. Library size was determined by plating a small portion of the transformed cells on NZY/Tet agar plates and counting Tet resistant bacterial colonies, which secrete phage.

DNA sequencing was performed on purified phage particles or on PCR amplified fragments derived from the DNA encoding the recombinant pVIII of phage clones. Sequencing was performed using either the Thermo Sequenase Radiolabelled Terminator Cycle Sequencing Kit (USB, Cleveland, OH) or the Thermo Sequenase II Dye Terminator Cycle Kit (Amersham Biosciences, Piscataway, NJ), following the manufacturer's instructions, or at the Centre for Molecular Medicine and Therapeutics at

the University of British Columbia (Vancouver, BC). DNA fragments generated using the radiolabeled kit were visualized using X-ray film and analyzed manually. DNA fragments generated using the Dye kit were resolved on an ABI 373 sequencing apparatus, and analyzed using the EditView 1.0.1 software.

2.4 Biotinylation of Antibodies

Biotinylation of 4E10 IgG and Fab was performed following the protocol of Menendez *et al.* (52). In a volume of 50 μ l phosphate-buffered saline (PBS), 50-100 μ g of antibody was mixed with 11 μ l of 1 M bicarbonate buffer and 50 μ l of a 0.5 mg/ml solution of sulfo-NHS-LC biotin in 2 mM sodium acetate, pH 6.0 and incubated at room temperature for 2 hours. The reaction was stopped by the addition of 500 μ l of 1 M Tris-HCL, pH 7.4 and allowed to incubate for a further 30 minutes. BSA (20 μ l, 50 mg/ml) was added to the solution as a carrier protein followed by 1 ml of Tris-buffered saline (TBS). The reaction was then washed three times in a Centricon-50 apparatus (Millipore). After washing, an equal volume of sterile, 100% glycerol was added followed by sodium azide to final concentration of 0.02% (w/v). Biotinylated antibodies were stored at -20°C .

2.5 Screening of Peptide Libraries and Selection of Clones

The protocols for in-solution and solid-phase panning were adapted from Menendez *et al.* (52). The in-solution panning was carried out in 1.5 ml microcentrifuge tubes. Prior to the affinity selection by antibody, library phage were subjected to a pre-adsorption step for every round of selection to remove non-specific binding phage. The phage libraries were incubated with 60 μ g streptavidin-coated magnetic beads (Dynal,

Lake Success, NY) in a total volume of 50 μ l TBS with 0.5% Tween 20 for 6 hours at room temperature. The pre-adsorbed phage were then separated from the beads using a magnet (Dyna) and transferred to a new microcentrifuge tube. Biotinylated antibody was added to the libraries and the final volume adjusted to 100 μ l with 2% BSA/0.5% Tween 20. The phage library-antibody reactions were incubated overnight at 4°C while rotating and then transferred to a new tube to prevent the capture of tube-binding phage. Streptavidin-coated magnetic beads (20–60 μ g) were added to the mixture and incubated for 30 minutes at room temperature to capture phage-antibody complexes out of solution. The magnetic beads were then washed 8 times with 200 μ l TBS/0.5% Tween 20 using either a magnet or a 96-well filtration plate and a vacuum manifold (Millipore). After the final wash, beads were re-suspended in 50 μ l TBS to which 50 μ l of starved K91 cells were added and incubated for 15 minutes at room temperature to allow infection to take place. Luria Broth (LB) supplemented with 0.4 μ g/ml Tet was added to the infections and allowed to incubate for 45 minutes at 37°C to induce the Tet resistance gene of the phage. A 5 μ l aliquot of the infections was taken for spotting on NZY plates supplemented with 40 μ g/ml Tet to calculate the phage yield. The remaining infection mixture was transferred to 2 ml NZY/Tet/IPTG and allowed to grow overnight at 37°C with shaking. Overnight cultures were spun in microcentrifuge tubes to pellet cells. Phage particles were purified from the supernatant and concentrated by precipitation with PEG/NaCl and then re-suspended in TBS containing 0.02% (w/v) sodium azide. Phage concentrations were estimated by agarose gel electrophoresis of lysed phage particles and visualization of ethidium bromide stained viral DNA by UV light. PEG-purified phage were then used as the input in the subsequent round of panning.

Solid-phase panning on beads was carried out in a similar manner as the in-solution panning described above with a few modifications. Excess streptavidin-coated magnetic beads were incubated with a biotinylated antibody then washed, in order to coat the beads with antibody. The pre-adsorbed libraries were then incubated with the antibody-coated beads for 2 hours at room temperature while rotating. To help reduce non-specific binding phage, 100 μ l 1 mM D-Biotin (ICN Biomedicals Inc., Irvine, CA) in 2% BSA was added to beads before washing. Beads were washed ten times in round 1 and fifteen times in round 2. Infections were carried out as described above.

Isolation of phage clones from the panning pools was performed by infecting 30 μ l of starved K91 cells with 10^6 phage particles from the panning pool in 10 μ l TBS. Infections were incubated for 10 minutes and then Tet resistance was induced by the addition of 160 μ l of NZY supplemented with 0.02 μ g/ml Tet and incubation for 45–60 minutes at 37°C with shaking. Infections were then plated on NZY/Tet plates and grown overnight. Colonies were picked and used to inoculate 2 ml NZY/Tet/IPTG media and grown overnight at 37°C. Phage were PEG-purified and phage concentration estimated as described above.

2.6 Enzyme-Linked Immunosorbent Assays (ELISA)

Direct phage ELISAs were performed as described in Zwick *et al.* (105) with some modifications. The wells of 96-well, flat-bottom, polystyrene microtiter plates (Corning, Corning, NY) were coated with 2×10^{10} phage or 50 ng of recombinant gp41 in 35 μ l TBS overnight at 4°C. Wells were then blocked with 200 μ l of 2% BSA in TBS for 45–60 minutes at 37°C. Plates were washed three times with TBS containing 0.1%

Tween 20 using an automated plate washer (BioTek Instruments, Winooski, VT) or washed by hand by submerging in wash buffer and slapping dry on a stack of paper towels. Primary antibody was added to wells in TBS containing 1% BSA and 0.1% Tween 20 and incubated for 2 hours at room temperature. Plates were washed six times as described. HRP-conjugated secondary antibody in TBS containing 1% BSA and 0.1% Tween 20 or HRP-conjugated protein A/G in TBS containing 0.1% Tween 20 was incubated for 1 hour at room temperature. Wells were again washed 6 times. 2, 2'-azino-bis(3-ethylbenzthiazoline-6-sulfonic acid) (ABTS) was added to wells and colour development was allowed to proceed in the dark. Absorbance was measured using a Versamax microplate reader (Molecular Devices, Sunnyvale, CA) at 405nm–490nm. In order to ensure that similar amounts of phage had been adsorbed to all wells, replicate wells were coated with phage, detected with a polyclonal, rabbit-anti-phage antibody and developed as described. ELISA data are representative of multiple assays performed under slightly varying conditions or were performed in duplicate, or both.

Reducing ELISAs were performed as described for direct ELISA with an added DTT incubation step. After blocking with BSA, 35µl TBS containing 100 mM DTT was added to the “plus DTT” wells and TBS only added to the “no DTT” wells and incubated 30 minutes at 4°C. Wells were aspirated only. Primary antibody was added containing 5mM DTT for the “plus DTT” wells to prevent the reforming of disulfide bonds in peptides. Primary antibody alone was added to the “no DTT” wells.

Competition ELISAs were performed as described for direct ELISA, with the additional step of incubating the competitor (gp41 or H3A4 phage) with the primary

antibody overnight at 4°C before addition to the ELISA. Primary antibody without competitor was also incubated overnight at 4°C for addition to the no competitor wells.

2.7 Sodium Dodecylsulfate-Polyacrylamide Gel Electrophoresis (SDS-PAGE) Analysis of the Major Coat Protein, pVIII

SDS-PAGE analysis was carried out following the protocol of Zwick *et al.* (105), which was modified from that of Schagger and von Jagow (84). The major coat protein of f88.4 phage was resolved on a 16% polyacrylamide, gel using either a Hoefer SE4000 electrophoresis apparatus (Amersham Biosciences) or Bio-Rad Mini-PROTEAN® II Electrophoresis Cell (Bio-Rad Laboratories, Hercules, CA). Gels were run using a tris-tricine based buffer system. Phage samples were mixed with sample buffer containing SDS and glycerol and boiled for 5 minutes to lyse phage and denature proteins before loading onto gel. Gels were silver stained (56).

2.8 Dot Blot Analysis of Phage Clones

Dot blot analysis was carried out on phage clones grown using a modified protocol. Infection of K91 starved cells and plating of the infections was performed as described above. Single colonies were used to inoculate the wells of a 96-deep-well plate containing 1 mL of NZY/Tet/IPTG and grown overnight at 37°C with shaking. The next day, deep well plates were centrifuged at 3000-3500 rpm for 25-30 minutes. A volume of 50 µL of the supernatant was added to the wells of a Bio-dot microfiltration apparatus (Bio-Rad Laboratories) containing a nitrocellulose membrane (Millipore). Supernatant was allowed to filter through by gravity for 30-40 minutes. Wells were washed by adding 100 µL of TBS pulled through with vacuum. The apparatus was disassembled

and the membrane was incubated in a solution of non-fat dry milk (NFDM) at 37°C for 30-40 minutes to block the membrane. After blocking, the membrane was incubated with biotinylated-4E10 IgG at room temperature for two hours. Following this incubation, the membrane was washed briefly with TBS containing 0.1% Tween 20, then washed for fifteen minutes in NFDM and finally washed twice for five minutes in TBS. After washing, the membrane was incubated with Protein A/G-HRP in a solution of NFDM containing 0.1% Tween 20 for one hour at room temperature. Membrane was washed briefly with TBS containing 0.1% Tween 20, then washed once with NFDM for fifteen minutes and finally washed four times for five minutes with TBS containing 0.1% Tween 20. The dot blot was developed using the ECL Western Blotting Detection Kit (Amersham Biosciences) following the manufacturers instructions and exposed to X-ray film.

3 RESULTS

3.1 Screening of Primary Libraries with 4E10 IgG

Biotinylated 4E10 IgG was used to screen a panel of 15 phage-displayed random peptide libraries grouped into three pools as shown in Table 1. The displayed peptides were fused to the N-terminus of the major coat protein, pVIII and expressed on hybrid phage bearing both the recombinant pVIII protein as well as wild type pVIII (9). The screening was carried out as three rounds of affinity purification done in-solution with capture on streptavidin-coated beads. Phage input for the first round was calculated in order to add approximately 10-80 copies of virus per clone, if possible, with a total number of phage particles of approximately 10^{11} phage per pool. Subsequent rounds were completed under the same conditions as round one with the exception that the phage input was decreased to 10^{10} phage per pool.

Table 1. Primary Peptide Libraries Used in Initial Screening.

Pool	Library	Peptide Sequence	Library Size	Copies/Clone in 10 ¹⁰ phage	Total Phage Used In Screening
A	X6	X6	8 x 10 ⁸	12	3 x 10 ¹⁰
	X15	X15	1.3 x 10 ⁹	7	
	X8CX8	X8CX8	2.5 x 10 ⁸	40	2 x 10 ¹⁰
	X15CX	X15CX	1.2 x 10 ⁸	83	2 x 10 ¹⁰
	XCX15	XCX15	1 x 10 ⁹	10	5 x 10 ¹⁰
B	LX-4	XCX4CX	2.2 x 10 ⁸	45	2 x 10 ¹⁰
	LX-6b	XCX6CX	1.5 x 10 ⁸	66	2 x 10 ¹⁰
	LX-6	XCX6CX	1 x 10 ¹⁰	1	2 x 10 ¹⁰
	LX-10	XCX10CX	1.4 x 10 ⁸	71	2 x 10 ¹⁰
	LX-12	XCX12CX	1.4 x 10 ⁹	7	2 x 10 ¹⁰
C	LX-8	XCX8CX	1.5 x 10 ⁹	6	4 x 10 ¹⁰
	Cys 3	X5CX3CX4	5.2 x 10 ⁷	192	1 x 10 ¹⁰
	Cys 4	X4CX4CX4	1.7 x 10 ⁸	58	2 x 10 ¹⁰
	Cys 5	X4CX5CX4	5.9 x 10 ⁸	17	3 x 10 ¹⁰
	Cys 6	X4CX6CX4	2.7 x 10 ⁸	37	2 x 10 ¹⁰

A total of 80 clones was picked from the output pools and tested by ELISA for binding to 4E10 IgG. Fourteen of the clones tested positive and DNA sequencing was carried out on these clones to deduce the amino acid sequence of their displayed peptide. The nine strongest binding clones all had the same sequence and clone, 10A.3 was taken as representative of that group (Table 2). The five remaining clones all had weak ELISA signals. Three of these clones displayed the same peptide and clone, 10B.5 was taken as representative of this group. Other unique clones were named 10B.23 and 10B.7 (Table 2). Because of the low number of positive clones and the low diversity of sequences, the screening was repeated.

Table 2. Phage Clones Selected from Primary Libraries with 4E10.

Clone	ELISA ^a	Peptide Sequence ^b
10A.3	1.19	AEP <u>A</u> ET <u>S</u> W <u>F</u> Y <u>L</u> T <u>T</u> F <u>L</u>
10B.23	0.20	DCKQSSANFWV <u>V</u> S <u>F</u> C <u>L</u>
10B.5	0.12	SCQREEW <u>V</u> C <u>V</u>
10B.7	0.06	QCSSIFR <u>D</u> C <u>Q</u>
E6.8	1.14	RCRTIDVFR <u>N</u> C <u>I</u>
E2.15	0.94	ECS <u>N</u> W <u>H</u> T <u>L</u> T <u>A</u> R <u>M</u> W <u>L</u> R <u>N</u> M
E6.10	0.70	T <u>C</u> G <u>T</u> F <u>S</u> <u>N</u> W <u>F</u> D <u>C</u> S
E4.7	0.45	S <u>C</u> E <u>S</u> <u>N</u> W <u>F</u> M <u>C</u> S
E2.5	0.15	M <u>S</u> P <u>E</u> L <u>L</u> P <u>S</u> W <u>F</u> N <u>I</u> S <u>L</u> N <u>L</u> T
E6.1	0.07	A <u>C</u> D <u>N</u> F <u>F</u> L <u>L</u> S <u>W</u> C <u>M</u>
E2.3	0.06	N <u>C</u> H <u>K</u> S <u>D</u> T <u>F</u> W <u>K</u> I <u>T</u> D <u>C</u> L <u>R</u>
E6.6	0.06	S <u>C</u> T <u>N</u> W <u>F</u> I <u>M</u> S <u>T</u> C <u>L</u>
f88.4	0.02	
no phage	0.03	

^aELISA data are expressed as Optical Density (OD) readings at 405nm-490nm

^cUnderlined residues indicate sequences that align with the cognate epitope NWF(N/D)IT

The second screening of the libraries was carried out with the same library mixes as the first screening, with the exception that the X15 library was dropped from pool A. This library was dropped because it was the one from which the clone 10A.3 came, and this clone appeared to dominate in the screening. The first two rounds of selection were performed with biotinylated 4E10 IgG in solid phase on streptavidin-coated beads. This was done to decrease the stringency as compared to that in the first screening of the libraries, as it was assumed that the lack of diversity seen in that screening was due to excessively high stringency. Library mix A was not carried through to the third round, since this pool had a positive phage yield and showed moderate binding to 4E10 by ELISA after the second round (data not shown). The other pools were carried through a third round of screening in solution with capture on streptavidin-coated beads.

A total of 40 clones was picked from the positive pools of the second screening. Positive clones showed binding to 4E10 in a similar range as the clones from the first screening of the libraries, with four clones showing strong or moderate binding and four clones showing weak binding (Table 2). DNA sequencing was carried out on these clones and their peptide sequences were determined (Table 2). There was no strong consensus sequence seen among the clones from the two screenings, however, the motif NWF, or the variation SWF, was seen in a number of clones from both screenings (underlined residues, Table 2). This is not surprising given that the putative 4E10 epitope on gp41 is NWFDIT (88, 104) with some variations among isolates including SWFDIT (Los Alamos database, <http://hiv-web.lanl.gov>). Of note, however, is the clone E2.5, whose sequence is very close to the entire 4E10 epitope, SWFNIS, and yet is one of the weakest binding clones. In contrast, clone 10A.3 (SWFYLT), which also contains a consensus with the epitope on gp41, showed relatively strong binding to 4E10 by ELISA.

SDS-PAGE analysis of the phage clones did not show visible recombinant peptide-pVIII bands for any of the clones with the exception of the very weakly binding clone, 10B.7 (Figure 3). The SDS-PAGE was repeated using a longer Hoeffler gel, or using a modified SDS-PAGE system that included urea in the resolving gel (as described in (106)), in an attempt to obtain resolution of the recombinant peptide-pVIII bands, but with no improvement in results (data not shown). It often can be difficult to resolve the recombinant peptide-pVIII band from the wild type by SDS-PAGE (9, 106), due to the small size and hydrophobic nature of the pVIII protein and the peptides. Western blot analysis was also performed with 4E10 IgG, however, background was high and there was binding to the negative control f88.4 phage (data not shown). It is possible that this

resulted from the non-specific binding of 4E10 discussed in the introduction. It is possible to perform amino acid analysis of the phage to determine copy number of the recombinant peptide-pVIII protein, however, this analysis usually does not produce reliable results. Therefore, attempts to determine the copy number of the recombinant peptide-pVIII protein were unsuccessful.

Figure 3. SDS-PAGE Analysis of the Major Coat Protein of Phage Clones from the Screening of the Primary Libraries.

Electrophoresis of the phage clones isolated from the screening of the primary libraries. The position of the wild-type pVIII band is indicated in (A) and the positions of the wild-type pVIII band and the recombinant pVIII band that displays the peptide in (B). The names of the clones are shown below their position on the gels.

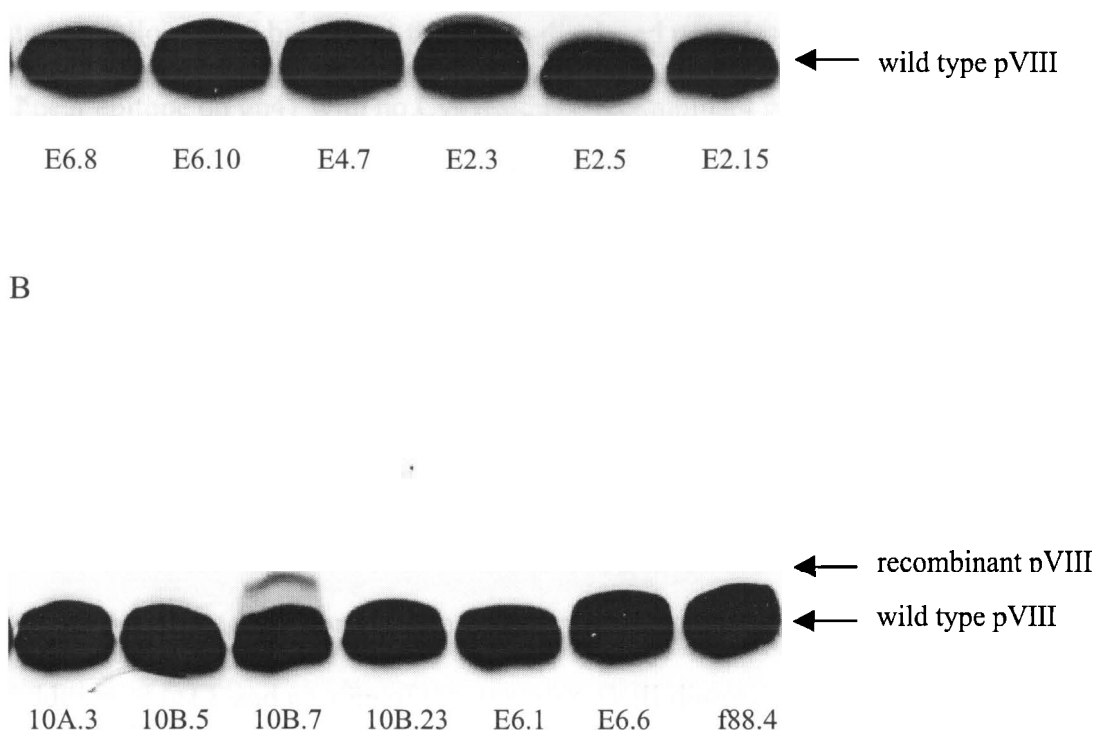

Of the clones without the (N/S)WF motif, many appear to have a significant number of aromatic and hydrophobic residues, and include two clones, E2.3 and 10B.23, which have the WF motif in reverse. It is also of note that one of the best binding clones, E6.8, appears to have little or no homology with the 4E10 epitope or with other clones from the screening. However, like the clones E2.3 and 10B.23, it has a part of the 4E10

epitope (DIT) in reverse. Ten of the twelve clones from the two screenings contained one or more Cys residues.

To determine if the binding of these clones to 4E10 was dependent on possible disulfide bridges between Cys residues, ELISA was performed under reducing conditions. Phage adsorbed to the ELISA plate were treated with 100 mM DTT to reduce disulfide bonds. 4E10 IgG, in the presence of a small concentration (5 mM) of DTT, was then added to the ELISA wells to prevent re-oxidation of the sulfhydryls and at the same time to allow 4E10 binding to the phage-displayed peptides. Because 4E10 binds to a linear epitope on gp41 with no Cys residues, recombinant gp41 was included in the ELISA as a control. The ELISA signals for the majority of the Cys-bearing clones were reduced to background with addition of DTT, the only exceptions being E2.15, and to a lesser extent, E6.6, and E6.1 (Figure 4). Clone E2.15 contains a single Cys residue in its displayed peptide (Table 2) and it is expected that the Cys residues of its displayed peptides could form a disulfide bridge with Cys residues of an adjacent peptide on the surface of the phage coat, forming homodimers, as shown by the work of Zwick *et al.* (106). However, this clone showed no significant reduction in binding to 4E10 with the addition of DTT and no sign of recombinant pVIII dimers on SDS-PAGE (Figure 3A), suggesting that the presence of a disulfide bridge is not necessary for binding to 4E10. The binding of the clones E6.6 and E6.1 to 4E10 was reduced to about half upon addition of DTT, and this may reflect a partial dependence of binding upon possible disulfide bonds. However, it may also reflect the effect of the presence of a small amount of DTT on the antibody as can be seen as a slight reduction in binding of 4E10 to gp41.

Because the clones E6.6 and E6.1 bind weakly to 4E10 they may be more sensitive to this effect.

Figure 4. DTT ELISA of Cysteine-Containing Clones from the Screening of the Primary Libraries.

Phage clones were immobilized to the wells of a microtiter plate and incubated either with DTT to reduce disulfide bonds (+DTT) or without DTT (-DTT). Antibody was added with a small amount of DTT to prevent reforming of disulfide bonds in the +DTT wells. OD was read at 405-490 nm.

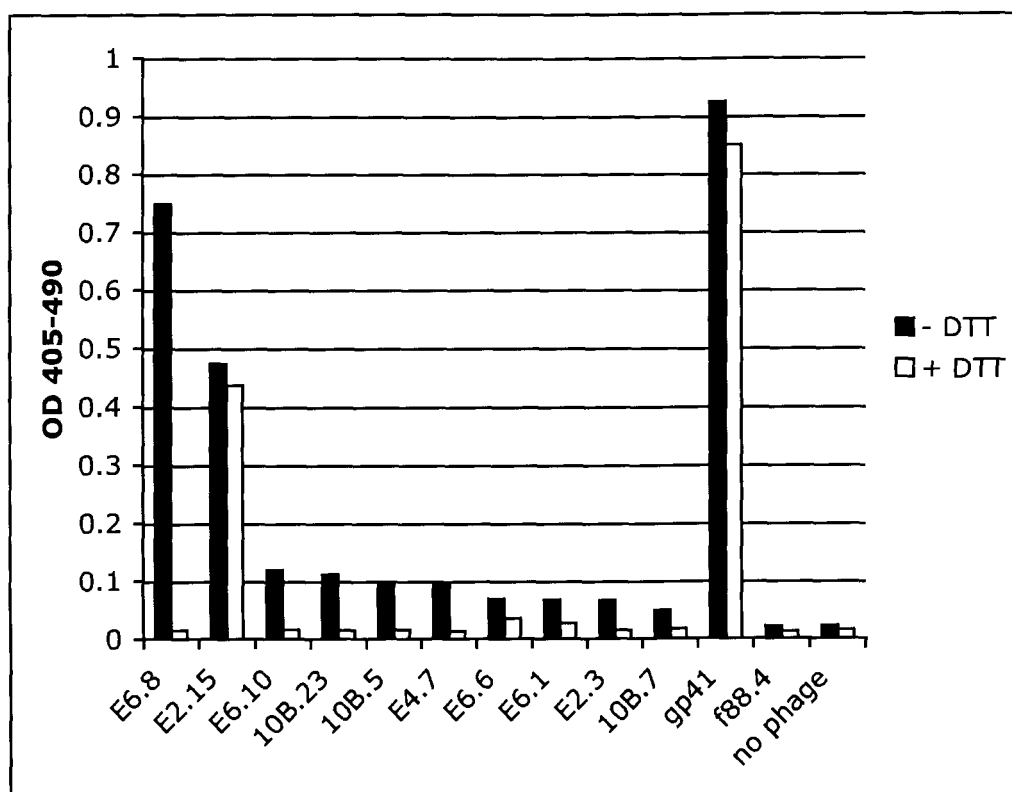

Based on the ELISA data (Table 2), clones 10A.3 and E6.8 were identified as the two best binding clones and were chosen for further analysis and optimization. These clones showed very similar binding to 4E10 by ELISA and yet display very different peptide sequences, thus representing two different types of peptides to which the 4E10 MAb is able to bind. 10A.3 appears to be a linear representation, and therefore a mimic,

of the native epitope on gp41, whereas E6.8 is a constrained peptide whose binding mechanism probably differs from that of the native epitope.

3.2 Doped Libraries Based on the Clones 10A.3 and E6.8 and Screening of the Libraries

3.2.1 Construction of the Doped Libraries

To optimize binding and to further characterize the clones 10A.3 and E6.8, two doped libraries were constructed based on their peptide sequences. The synthesis of the oligonucleotides for the construction of the libraries was performed following the two-column method of Glaser *et al.* (34). Briefly, the synthesis was carried out using two columns in parallel such that one column was used to synthesize the trinucleotide coding for the first residue of the parental peptide and the other column was used to synthesize a random “NNK” trinucleotide codon (where “N” represents a mixture of A, C, G and T nucleotides and “K” represents a mixture of G and T) as the first residue. The beads from the two columns were then removed and mixed, yielding a mixture of 50% parental codon and 50% degenerate codon encoding the first amino acid residue. The beads were then divided in half and placed back in the two columns for the synthesis of the next trinucleotide codon in the same manner, through the synthesis of the complete parental sequence. The resulting libraries contained clones with a bias favouring the parental peptide (Table 3 and Table 4).

Table 3. Analysis of Amino Acid Bias in the Doped Libraries.

A:

10A.3 parental residue	A	E	P	A	E	T	S	W	F	Y	L	T	T	F	L
Expected frequency parental residue	57 ^a	53	57	57	53	57	60	53	53	53	60	57	57	53	60
Observed frequency before selection	44	33	56	33	44	56	33	56	11	67	56	56	33	44	67
Observed frequency after selection ^b	74	58	79	42	84^c	68	10	100	100	47	95	100	68	58	95
Consensus	X	X	X	X	E/S	X	N	W	F	X	L	T	X	F/L	L

B:

E6.8 parental sequence	R	C	R	T	I	D	V	F	R	N	C	I
Expected frequency parental residue	60	53	60	57	53	53	57	53	60	53	53	53
Observed frequency before selection	73	73	64	45	27	73	45	45	9	73	45	36
Observed frequency after selection ^d	61	100	22	61	100	100	83	100	100	100	100	74
Consensus	X	C	X	X	I	D	V/I	F	R	N	C	I/V/L/F

^aValues are expressed as percent.

^bBased on data from Table 6

^cBolded numbers represent antibody selected parental residues whose frequency increased by >40%, or to >90%

^dBased on data from Table 8

Table 4. Analysis of Clones from the 10A.3 and E6.8 Doped Libraries.

Clone	Peptide Sequence	ELISA ^a
10A.3 parental	AEPAETSWFYLTTFLL	1.13
10A.3-1	AMRABGWYRYLTTL	0.06
10A.3-2	EEHQETDWMHQTVSL	0.05
10A.3-3	AMPPFTFWRYLTTFLL	0.04
10A.3-4	AYPAVTGWLYLSHFT	0.05
10A.3-5	IELRGTSWFBNLTFLL	0.05
10A.3-6	IEPTEFSWSYLTLLKL	0.04
10A.3-7	LTDCSQFFSYFQLB ^b	0.05
10A.3-9	AHPSETSPGYLTLILL	0.06
10A.3-10	NVPAEGDDPAKAAFD	0.08
E6.8 parental	RCRTIDVFRNCI	0.60
E6.8-1	RSRTIKPFFNRS	0.04
E6.8-2	RCRMIDVFSNCY	0.05
E6.8-3	RCQMDDSPLNKI	0.06
E6.8-5	RCHTLDVWKNKN	0.05
E6.8-6	nd ^c	0.05
E6.8-7	RKRGVSVBWNCT	0.06
E6.8-8	RCRTLDFKFSRPM	0.06
E6.8-9	VCREMDBRSNCD	0.06
E6.8-10	NCRTIDVQRHTI	0.05
E6.8-11	RSDATDPFINRI	nd
E6.8-12	YCRTSDVFLVKR	nd
E6.8-18	RCYCLHPPFNCI	nd
f88.4		0.05
no phage		0.03

^a OD readings at 405nm-490nm

^b B = amber stop codon

^c nd = not done

Clones were picked at random from each library for ELISA and sequencing analysis (Table 4). Table 3 shows the results of an analysis of the amino acid bias found in the sequences of the clones picked from each library. In the 10A.3 doped library, approximately half of the residues from the parental sequence appear in the library clones in similar frequencies as those expected. A few residues appear slightly more often or slightly less often. There is only one residue, Phe9, that appears in only about 11% of the clones picked. The E6.8 doped library seems to have a stronger bias towards the parental

sequence with four out of the twelve residues showing up considerably more frequently than expected. There are also two residues, Ile5 and Arg9 that appear in a very low percentage of the library clones, 27% and 9% respectively. This result is not entirely unexpected, however, because the division of the beads for the two columns in the synthesis of the library oligonucleotides is done by eye. It is therefore, very difficult to ensure an accurate 50/50 division of the beads every time. Alternatively, there could be a biological bias favouring certain residues at particular locations in the sequence. In either case, it was not expected that re-synthesizing the oligonucleotides for the E6.8 library would change the bias towards the parental clone significantly and so the library was used. Table 4 shows the results of a representative ELISA to test the binding of the randomly selected clones to 4E10. None of the clones bound to 4E10. Binding to the whole libraries was also similar to background, as discussed on page 44. Therefore, any positive clones picked from the screening will have come through as a result of affinity selection by 4E10.

3.2.2 Screening of the Doped Libraries

The initial screening of the doped libraries was done in solution with capture on streptavidin-coated beads. Biotinylated 4E10 Fab was used in all rounds of the screening following the strategy shown in Figure 5. None of the output pools for the screening of the E6.8 doped library were positive by ELISA (Table 5) so this screening was repeated. The first screening of the 10A.3 doped library, however, yielded several positive pools, and clones were picked from the pools R2A and R2B (in bold, Table 5). In order to screen a large number of clones, positive clones were first identified by dot blot analysis (data not shown) and then amplified and further analyzed by ELISA and DNA

sequencing. All of the clones that were sequenced displayed the same peptide (clone D4C10, Table 6) and so this library was also screened a second time. It is possible that using Fab in the first round of screening led to the loss of many clones due to excessively high stringency, and low capture yields. The bivalent binding of IgG may instead capture a wider range of clones with higher efficiency, thus selecting a greater diversity of phage in the first round. It is also possible that the concentration of Fab used in the screening was too low and contributed to the loss of diversity in clones in the screening and so higher concentrations were used in the next screening.

Figure 5. Flow Chart of the First Screening of the Doped Libraries.

Screening was performed as successive rounds of affinity purification. Antibody used in each round of selection is shown. Input for the first round was the whole library. Input for each subsequent round is derived from the output in the round preceding it, as indicated.

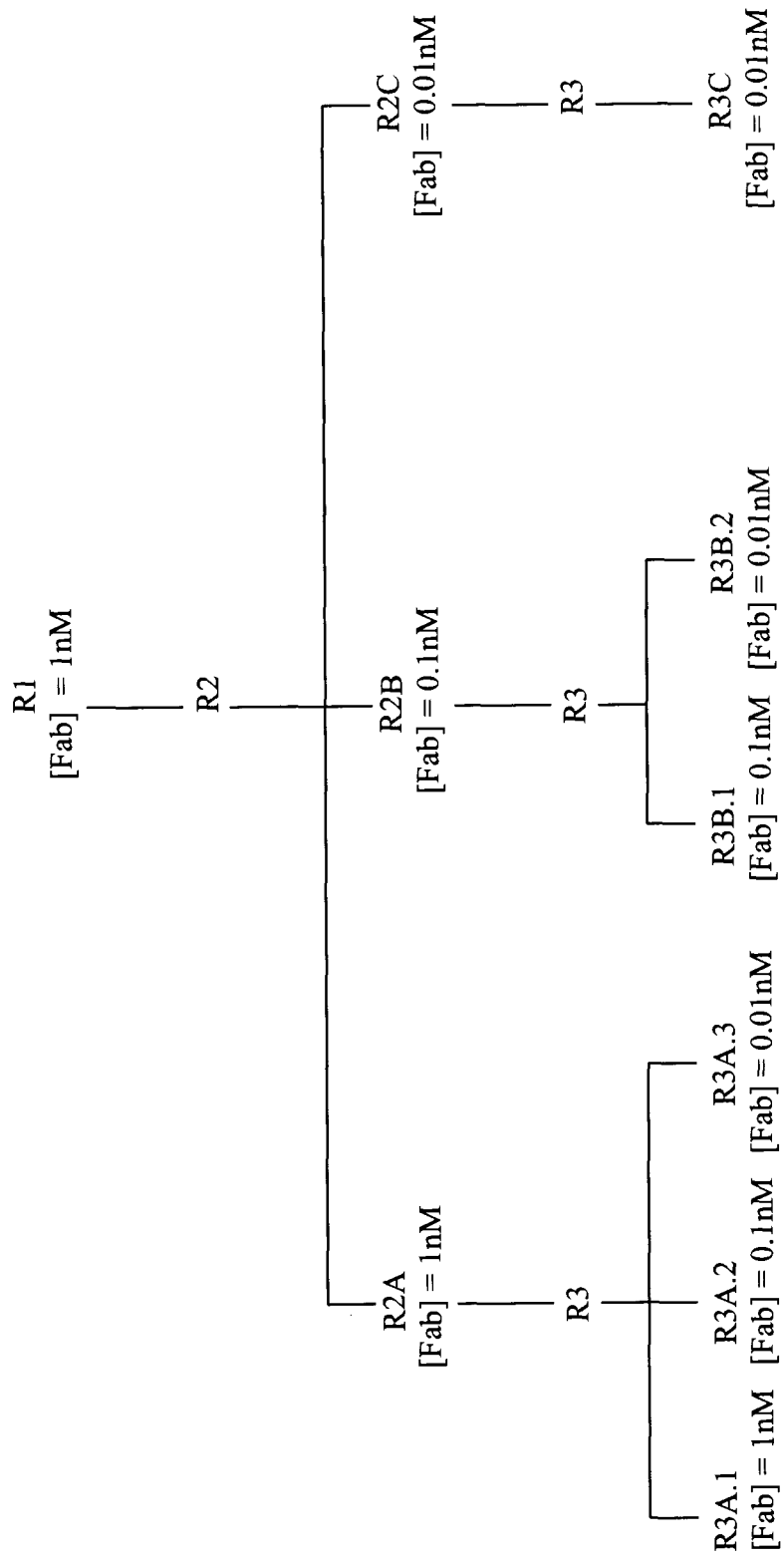

Table 5. ELISA of Pools from the First Screening of the Doped Libraries.

Pool	4E10 ^a	10A.3 ^b	E6.8 ^c
R1	1nM	0.15	0.11
R2A	1nM	1.03	0.11
R2B	0.1nM	0.35	0.12
R2C	0.01nM	0.17	0.13
R3A.1	1nM	1.10	0.10
R3A.2	0.1nM	0.39	nd ^d
R3A.3	0.01nM	0.51	nd
R3B.1	0.1nM	0.13	0.12
R3B.2	0.01nM	0.13	nd
R3C	0.01nM	0.11	0.11
library		0.10	0.10
parental clone		0.41	0.84
f88.4		0.10	

^aConcentration Fab used in screening

^bOD readings at 405nm-490nm of output pools from the screening of the 10A.3 doped library

^cOD readings at 405nm-490nm of output pools from the screening of the E6.8 doped library

^dnd = not done

Table 6. Clones from the Screening of the 10A.3 Doped Library, their Peptide Sequences and ELISA Signals.

Clone	Peptide Sequence ^a	ELISA ^b
10A.3 (Parental)	A E PA E T S W F Y L T T F L	0.05
H3A4	A E PA E N N W F M L T Y F L	1.76
H3D1	A P PA E T N W F N L T Y E L	1.64
H3A9	A V PRE T N W F A L T T W L	1.61
H3B6	A E PA E V N W F V L T Y F L	1.58
H4E3	A E IA E T N W F L L T T F L	1.52
H3A6	A E P W ET N W F L L T T F L	1.50
H4H3	A E PG S T N W F A L T T F L	1.47
H4G2	A Q PA E T N W F L L T F F L	1.42
H3D8	N A PP E T N W F Y L T T L L	1.39
H4E5	H K PE E T N W F Y L T T L L	1.31
D4C10	K G P V ET N W F Y L T T L L	0.94
H3C4	A E P Y ET N W F Y L T T L L	0.78
H3C8	A E PA E T N W F Y L T T F L	0.38
H4E4	A G PT E I N W F Y L T T F L	0.29
H4G4	A E PS S T N W F Y L T T L L	0.27
H3C7	A E PA E A N W F Y I T T F L	0.18
G3H9	M E Y Q H T N W F Y L T W F L	0.12
H4G5	A E Q S E F S W F L L T T F M	0.07
G3F4	G M SA E PS W F G L T L S L	0.03
gp41 HxB2	E L DK W AS L W N W F N I T N W L V I K	1.23
f88.4		0.02
no phage		0.02

^aBold residues indicate residues in consensus

^bOD readings at 405nm-490nm of 4E10 Fab binding

The screening of both libraries was repeated using 4E10 IgG in the first round and 4E10 Fab in subsequent rounds (Figure 6). ELISA was again performed on the output to identify positive pools (Table 7). Both 4E10 Fab and 4E10 IgG were used to test the pools. Binding to the whole libraries was similar to background with both IgG and Fab. However, all of the output pools from both libraries were positive with the IgG, but the Fab, being monovalent, showed much better discrimination and was thus used in all of the remaining ELISAs. Three of the pools from the screening of the 10A.3 doped library

clearly show much stronger binding to 4E10 Fab than any of the others, and so clones were picked from these pools (in bold, Table 7). None of the pools from the screening of the E6.8 doped library showed this same dramatic increase in binding to 4E10, however, there were a few pools that did show some binding, although not as high as the parental clone. This could be due to the fact that the 4E10 binding clones within these pools either do not bind to 4E10 as well as the parental clone, or that the binding clones represent a minority within the pool. Because binding to 4E10 dropped in the round 3 pools, clones were picked from the pools preceding round 3 (in bold, Table 7).

Figure 6. Flow Chart of the Second Screening of the Doped Libraries.

Screening was performed as successive rounds of affinity purification. Antibody used in each round of selection is shown. Input for the first round was the whole library. Input for each subsequent round is derived from the output in the round preceding it, as indicated.

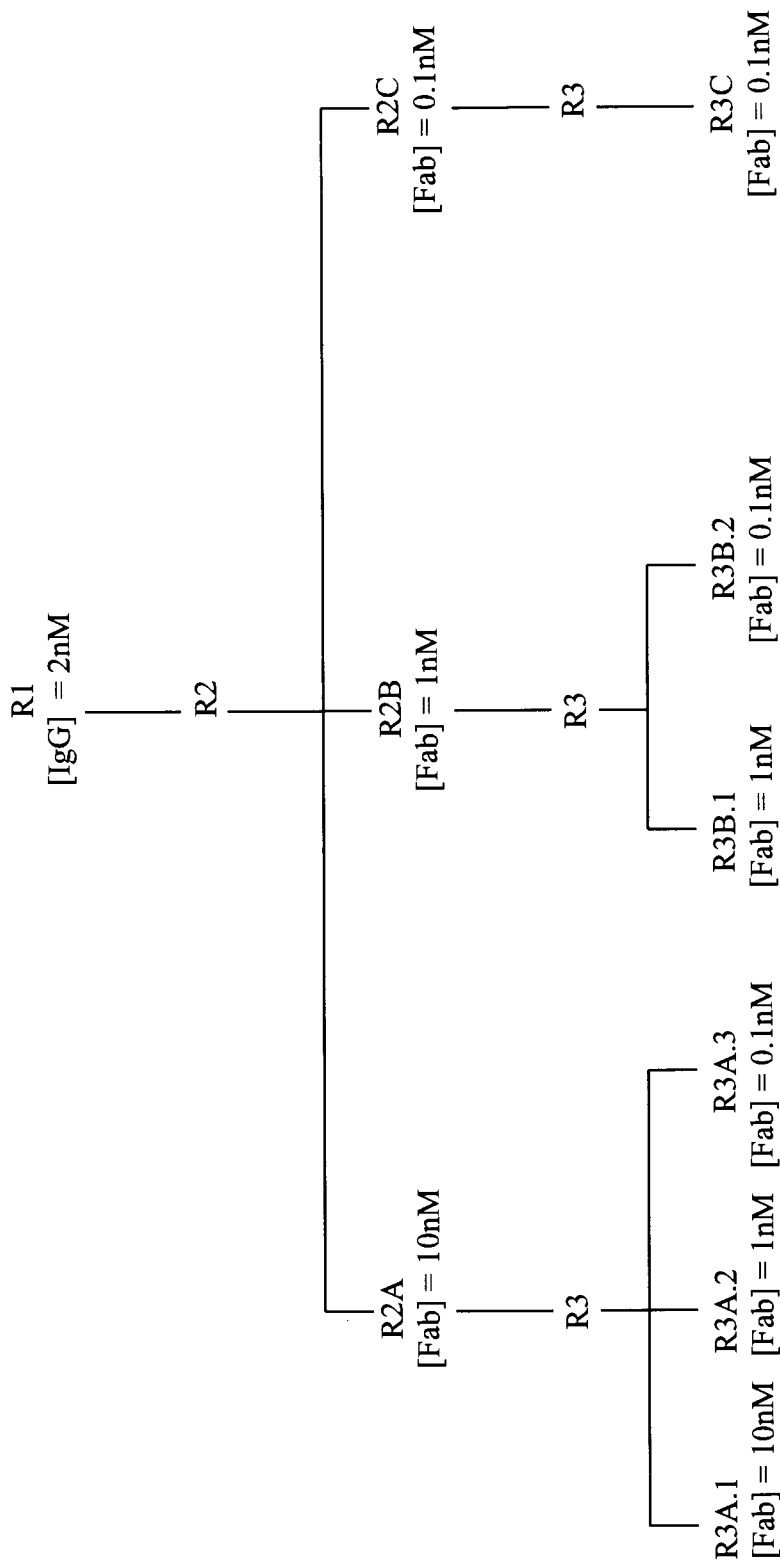

Table 7. ELISA of Pools from the Second Screening of the Doped Libraries.

Pool	4E10 ^a	10A.3 doped library ^b		E6.8 doped library ^c	
		Fab	IgG	Fab	IgG
R1	2nM IgG	0.18	0.74	0.09	0.69
R2A	10nM Fab	0.75	0.78	nd ^d	nd
R2B	1nM Fab	0.39	0.76	0.14	0.76
R2C	0.1nM Fab	0.06	0.73	0.09	0.73
R3A.1	10nM Fab	0.35	0.77	0.07	0.66
R3A.2	1nM Fab	0.81	0.79	0.05	0.64
R3A.3	0.1nM Fab	0.82	0.81	-	-
R3B.1	1nM Fab	0.01	0.74	0.04	0.62
R3B.2	0.1nM Fab	0.17	0.61	0.04	0.58
R3C	0.1nM Fab	0.05	0.55	0.03	0.45
library		0.02	0.06	0.02	0.04
parental clone		0.09	0.69	0.16	0.73
f88.4		0.02	0.03		

^aConcentration of IgG or Fab used in screening

^bOD readings at 405nm-490nm of output pools from the screening of the 10A.3 doped library

^cOD readings at 405nm-490nm of output pools from the screening of the E6.8 doped library

^dnd=not done

3.3 Screening of Clones Picked from the Output Pools of the Doped Libraries

Clones were picked from the positive pools and screened by dot blot analysis.

Positive clones were amplified and further analyzed by ELISA and the best binding clones were sequenced (Table 6 and Table 8, for the 10A.3 and E6.8 doped libraries, respectively).

Table 8. Clones from the Screening of the E6.8 Doped Library, their Peptide Sequences and ELISA Signals.

Clone	Peptide Sequence ^a	Fab ^b	IgG ^c
E6.8	RCRTIDVFRNCI	0.23	0.76
E7G3	TCQTIDIFRNCI	0.71	0.79
E5E1	RCVQIDVFRNCI	0.61	0.76
E5E11	RCREIDVFRNCI	0.57	0.71
E5C8	RCPTIDIFRNCI	0.56	0.70
E5E4	SCPTIDIFRNCI	0.55	0.75
R1C4	RCTTIDVFRNCI	0.43	0.75
R1C10	RCVTIDVFRNCI	0.40	0.77
R1A8	NCLTIDVFRNCV	0.38	0.71
R1D4	RCNQIDVFRNCI	0.37	0.66
E5E12	SCLTIDIFRNCL	0.35	0.80
E7F2	TCRTIDVFRNCI	0.28	0.79
E5E3	ECQKIDVFRNCI	0.27	0.74
E7F11	RCRQIDVFRNCV	0.23	0.77
E5D4	RCAKIDVFRNCI	0.21	0.77
R1A11	RCRSIDVFRNCI	0.20	0.73
R1B9	SCSTIDVFRNCI	0.19	0.77
E5D2	RCDTIDVFRNCI	0.17	0.71
E5D6	RCQTIDVFRNCV	0.17	0.75
R1A10	RCITIDVFRNCI	0.15	0.73
R1B10	RCNVIDVFRNCI	0.14	0.75
R1C3	TCADIDVFRNCL	0.13	0.72
R1D3	RCPTIDVFRNCI	0.12	0.69
E5E2	ECRTIDVFRNCF	0.04	0.40
f88.4		0.02	0.01
no phage		0.01	0.01

^aBold residues indicates residues in consensus sequence

^bOD readings at 405nm-490nm with 4E10 Fab

^cOD readings at 405nm-490nm with 4E10 IgG

3.3.1 Clones from the 10A.3 Doped Library

Table 6 shows the clones picked from the screening of the 10A.3 doped library.

There were a number of clones that appeared multiple times. In fact, all clones sequenced from the first screening of this library were the same clone (D4C10). In the second screening, there was one clone that dominated. This clone, H3A4 was also one of the best binding clones with a consistently high ELISA signal. There were several other

clones that also appeared multiple times, including H4G4, which was the second most common clone, and yet was one of the weakest binding clones from this library. It is possible that this clone may have had a growth advantage, causing it to appear so frequently. Most of the clones, however, only appeared one or a few times. Diversity, therefore, was achieved with the second screening of the 10A.3 library.

As shown in Table 3 and Table 6, a strong consensus sequence can be seen among all the clones from the 10A.3 doped library screening: X₄(E/S)XNWF₄XLTX(F/L)L. The motif NWF₄XLTX can be seen in 95 percent of the clones and most likely represents the core of the epitope recognized on the peptide. This motif is also homologous to the putative 4E10 epitope on gp41 (NWF₄DIT). It is interesting to note that in the parental clone 10A.3, there is a Ser residue directly N-terminal to the WF, but an Asn residue seems to have been strongly selected, as it appears in all but only the weakest-binding clones picked from the screening. It is possible to speculate about what effect changing the Asn back to a Ser would have on the binding of these clones. There is one clone (H3C8) in which this is the only difference from the parental clone. The Ser to Asn change increases the binding almost ten fold from a 0.05 signal for the parental to nearly a 0.4 signal for the new clone, suggesting that this is a very important difference. However, there are other clones that have the Ser to Asn change but do not bind to 4E10 as well as clone H3C8. It is possible that some of the other changes in these clones are actually detrimental to binding, and somewhat counteract the improvement seen from the Ser to Asn change. It is also possible that the expression of recombinant pVIII by these clones is lower than that of the others. It is difficult to determine this, since the SDS-PAGE could not resolve wild type and recombinant pVIII (Figure 7A). This is most

likely due to the overall hydrophobicity of the peptide sequences and the pVIII protein, as discussed above.

Figure 7. SDS-PAGE Analysis of the Major Coat Protein of the Top Binding Clones from the Screening of the Doped Libraries.

(A) Electrophoresis of the phage clones isolated from the 10A.3 doped library. The control phage f88.4 shows the position of the wild-type pVIII band. (B) Electrophoresis of the phage clones isolated from the E6.8 doped library. Positions of the wild-type pVIII band, and the monomer and dimerized recombinant pVIII bands are indicated.

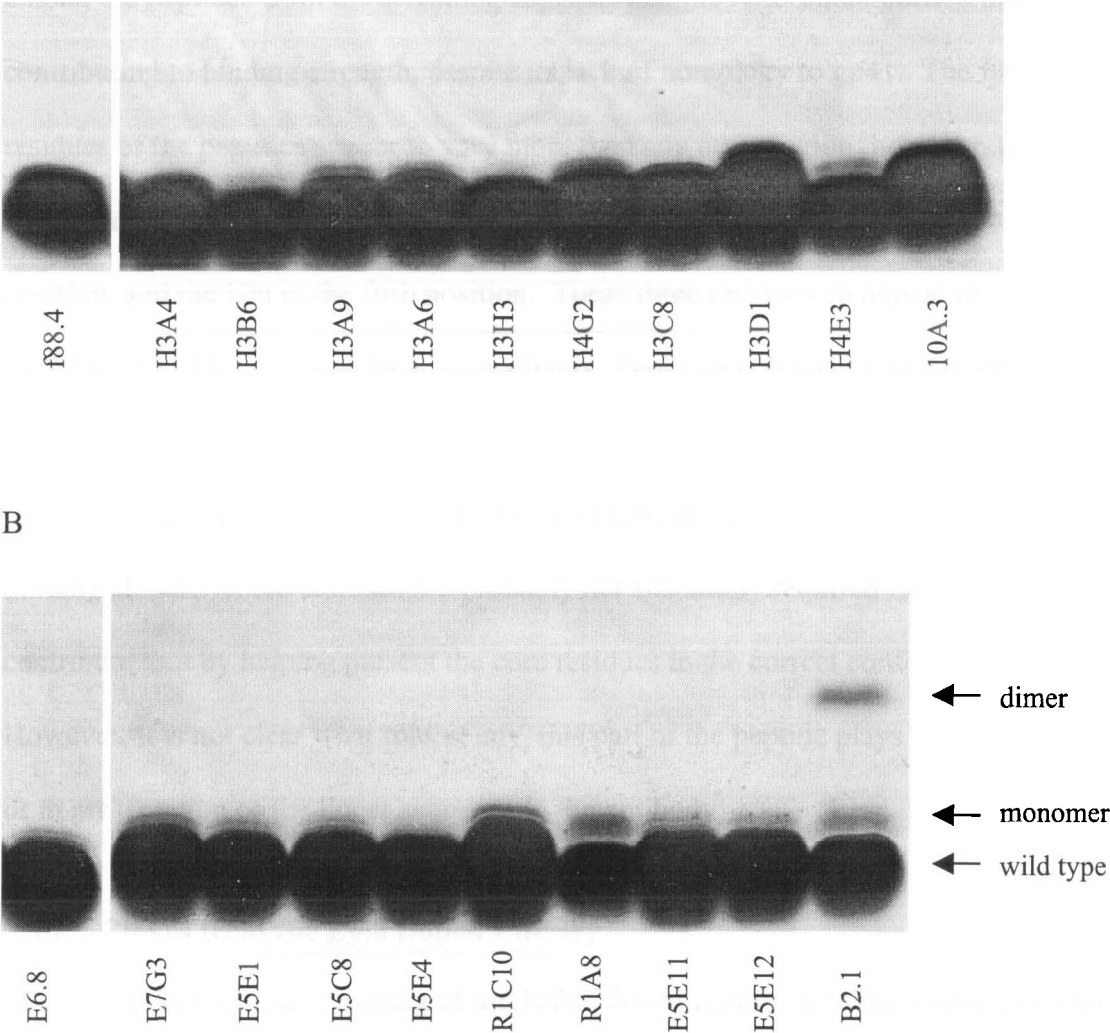

Additionally, there is a Leu residue in the +3 position from the final Thr of the putative 4E10 epitope that is present in 95 percent of the clones. In the +2 position from the Thr, there appears to be selection for either an aromatic residue (Phe or Trp) or a hydrophobic Leu residue. This (F/W/L)L motif aligns with the highly conserved WL in the gp41 sequence and suggests an expanded epitope necessary for optimal binding.

It is obvious that the above mentioned regions of the peptides are very important for binding to 4E10; however, the fact that there are such large differences in binding among the peptides from the screening suggests that the N-terminal portion may also be contributing to binding strength, despite its lack of homology to gp41. The first six residues of the peptides appear to vary more than any other region; however, there appears to be limited selection on three of the residues, the initial Ala, the Pro in the third position, and the Glu in the fifth position. These three residues all appear at increased frequencies (74%, 79% and 84%, respectively, Table 3A) compared to the initial library (44%, 56% and 44%, respectively, Table 3A). Additionally, there are fewer clones with changes at these positions among the strongest binding clones, than among the weaker binding clones. These residues are probably not absolutely required for binding, but may contribute to it by helping present the core residues in the correct conformation. However, it is not clear what role, if any, this part of the peptide plays in binding strength or in presentation of the linear sequence to the antibody.

3.3.2 Clones from the E6.8 Doped Library

Unlike with the screening of the 10A.3 doped library, there was little duplication of clones seen among those picked from the screening of the E6.8 doped library. In fact, only a few of the clones ever appeared more than once, and those that did, never appeared

more than a few times. There was, however, a very strong consensus sequence seen among the clones (in bold, Table 8): XCX₂ID(V/I)FRNC(I/V/L/F). The motif ID(V/I)FRNC(I/V) appeared in virtually 100% of the clones from the screening, even though there was not as strong a bias in the library for these eight residues as there was for the first four. Only two of the eight appeared more frequently than expected among clones in the initial library (Table 3B), suggesting that there was strong selection for this sequence. Additionally, both Cys residues of the parental clone E6.8 were present in every positive clone from the screening, despite the fact that they had not been fixed in the library. This supports the importance of a disulfide bridge in this sequence. This agrees with the finding that binding of the parental clone E6.8 to 4E10 IgG was reduced to background levels when assayed under reducing conditions (Figure 4). The results of Zwick *et al.* (106) have shown that phage displayed peptides bearing two Cys residues only rarely form intermolecular disulfide bonds to produce dimeric pVIII; they preferentially form intramolecular disulfide bonds. The fact that both Cys residues of the parental clone were found in 100% of the clones from the screening supports the notion that the two Cys residues in these peptides are forming intrachain disulfide bridges, and thus that the clones from the E6.8 library are constrained peptide ligands for 4E10. This was supported by the results of SDS-PAGE analysis of some of the clones from the screening of the E6.8 doped library (Figure 7B). None of the clones show a band migrating at the same mobility as the control clone, B2.1, which contains a single Cys residue in its displayed peptide and has previously been shown to form homodimers (106). Also, this was further emphasized by the results of an ELISA done under reducing

conditions in which the binding to 4E10 was reduced to near background for every clone (Figure 8).

Figure 8. DTT ELISA of Clones from the Screening of the E6.8 Doped Library.

Phage clones were immobilized to the wells of a microtiter plate and incubated either with DTT to reduce disulfide bonds (+DTT) or without DTT (-DTT). Antibody was added with a small amount of DTT to prevent reforming of disulfide bonds in the +DTT wells. Optical density was read at 405-490nm.

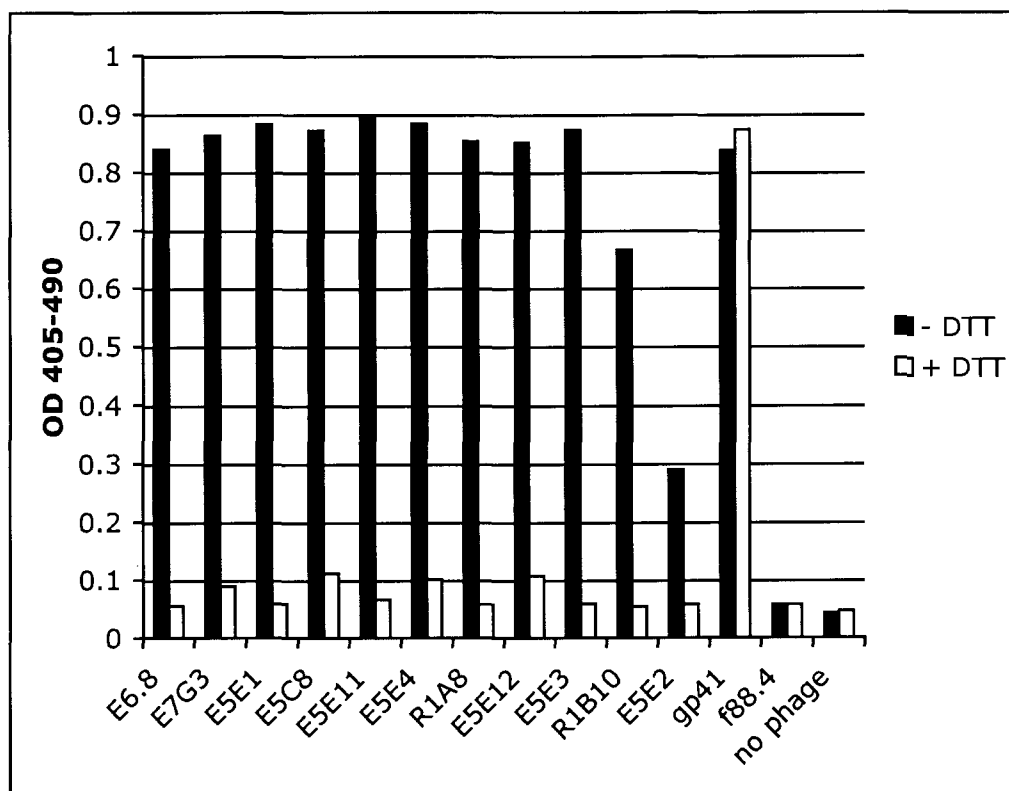

Because all of the peptides selected from the screening share an extremely strong consensus with at least two thirds of the parental clone E6.8, it could be expected that the improvement in binding over E6.8 seen with some of the clones must be due to changes in the remaining few residues of these peptides. However, there is no obvious pattern in the clones that suggests what might be responsible for this improvement in binding.

There does, however, appear to be some selection against the parental Arg residue at the

third position. It is present in only 22% of the clones from the screening versus 64% of clones in the initial library (Table 3B), and this is also despite the fact that there are 3 codons for Arg in “NNK” degenerate codons. It is also interesting to note that this Arg residue appears at a lower frequency among the clones that bind better than E6.8 to 4E10, than it does in those clones that do not bind as well. There does not appear to be selection for any particular type of amino acid in its place, with the exception that there also appears to be selection against aromatic and basic residues at this position. It should be noted, however, that these amino acids are all somewhat underrepresented in “NNK” degenerate codons with each amino acid having only one codon. Therefore, the absence of basic or aromatic residues could result from chance, due to the low frequency of codons for these types of residues.

There is also a fair amount of variation at the fourth position of the peptides. It had been suggested above that the TID sequence in the middle of the E6.8 peptide might represent a part of the 4E10 epitope (NWFDIT) in reverse order, and thus may be important for binding. If this were the case, it would be expected that this sequence should be found in most, if not all clones from the screening, and indeed, this was true for the dipeptide ID. However, the parental Thr is present in only slightly more clones from the selection than in the initial library (Table 3B), suggesting that there is little, if any, selection for this specific residue. The remaining half of the clones, however, contain mostly polar or charged residues, suggesting a possible selection against hydrophobic amino acids at this position. Additionally, the results from the screening of the 10A.3 doped library suggest that the most important residues for binding to 4E10 are the WF with help from the Thr6, but that the Asp is probably the least important, since this

position in the peptides seems to have the highest frequency of substitution. But, the WF motif was not a part of the E6.8 peptide and the ID that includes one of the least important residues for binding from the native epitope is actually entirely conserved in the clones from the cyclic library screening. Taken together, this indicates that the TID motif does not represent the reverse of the native epitope and the appearance of such in the parental clone E6.8 is just a coincidence.

As with the Thr in the fourth position, the parental Arg in the first position of the peptides appears in the same frequency as expected for the initial library (Table 3B). However, it is present in a lower frequency in the clones that bind more strongly to 4E10 than E6.8, and it is present in a higher frequency in the clones that bind more weakly than E6.8. But, some of the very best binding clones have this initial Arg in their peptides, suggesting that this result may be the result of chance. The remaining clones show a possible selection for a polar or aromatic residue at this position in place of the basic Arg. What, if anything, these patterns mean for the binding of these peptides to 4E10 is not clear.

3.3.3 Further Analysis of Optimized Clones

The goal of the construction and screening of the doped libraries was not only to further analyze the binding of the clones 10A.3 and E6.8 to 4E10, but also to optimize their binding. As there were several clones identified in the screening of both libraries that bound better to 4E10 than the parental clones, two of the best and most interesting clones from each library were chosen for further analysis. The clones H3A4 and H4H2 were chosen as optimized clones from the 10A.3 library. The clone H3A4 (Table 6) was chosen because it was consistently one of the best binding clones to 4E10 as well as

being the most common clone selected from the screening. The clone H4H2 was also chosen as one of the best binding clones and the initial sequence obtained for this clone was different from every other clone picked (data not shown). However, subsequent re-sequencing of this clone showed it has the same sequence as the clone H3A4, and so it was dropped from any further analyses. The clones E7G3 and E5E1 (Table 8) were chosen as the optimized clones from the E6.8 doped library. These two clones were chosen not only because they both bind more strongly to 4E10 than the parental clone, but also because they represent two interesting sequences. The clone E7G3 is a strong binding clone that does not have the Arg residue at the beginning of the peptide, and E5E1 is a strong binding clone that has the Arg as its initial amino acid. It is reasonable to suspect that some of the improvement in binding seen with the clone E7G3 may be due to an increased copy number of the peptide displayed on the phage surface as a result of the absence of a basic residue at the beginning of the peptide, however, SDS-PAGE analysis of the clones did not indicate this (Figure 7B).

Competition ELISA was performed to determine if the clones identified could compete with gp41 for binding to 4E10 (Figure 9, Figure 10 and Figure 11). Phage clones adsorbed to an ELISA plate were incubated with low concentrations of 4E10 Fab that had been pre-incubated either with or without recombinant gp41. It should be expected that if the clones bind to the same region of the antigen binding site on 4E10 as gp41, then the presence of gp41 in solution with the Fab should result in a decrease in the ELISA signal for binding to the phage. Although the ELISA signal was very low, competition was seen for the parental clone 10A.3, as the binding was reduced to background level upon the addition of gp41 (Figure 9A). 4E10 bound very strongly to

the optimized clone, H3A4, and did not show any competition (Figure 9A). There are several explanations for this result. It is possible that although the parental clone appears to bind to the same part of the antigen-binding site of 4E10, the optimized clone does not. It is not clear why this would be. However, it is also possible that due to the extremely strong binding produced by this clone, it is very difficult for gp41 to decrease this binding (i.e., affinity of 4E10 for the clone is similar to, or better than its affinity for gp41). This is demonstrated by the results of the competition of gp41 against gp41 where there is no significant reduction in binding. It can be presumed that even though there is no significant reduction in binding seen, that gp41 does indeed compete with itself for binding to 4E10. In an attempt to resolve this, a competition ELISA was carried out with gp41 adsorbed to the ELISA plate with the phage H3A4 in solution (Figure 9B). The results of this competition ELISA show a very slight reduction in 4E10 binding to gp41 upon incubation of the phage H3A4 with the Fab. Of note, however, is that there is even less reduction in binding observed for the phage clone against itself than against gp41, supporting the hypothesis that binding of 4E10 to this clone is so good that it is very difficult to see competition. It is possible that reducing the amount of antibody used in the competition would make it possible to alleviate this difficulty. In order to determine this, the competition ELISA was repeated using a lower concentration of Fab. First, a titration ELISA was performed on the parental and optimized clones as well as on gp41 (Figure 10A). 4E10 Fab was titrated on immobilized phage or gp41. The results of this titration demonstrate the extremely strong binding of the H3A4 clone in comparison to all the other phage clones as well as compared to gp41. It was determined from this ELISA that a concentration of 0.5 nM would be the optimum concentration to use in a

competition ELISA for H3A4 and gp41 because it produced a sub-maximal OD value. A concentration of 100 nM Fab was used in the competition for the parental clone 10A.3 (Figure 10A). Figure 10B shows the results of the competition ELISA. Binding to 10A.3 was reduced upon the addition of gp41 confirming the results of the previous competition ELISA. Once again, however, the addition of gp41 to 4E10 did not reduce binding to either H3A4 or to gp41 to background levels. However, incubation of the phage clone H3A4 in solution with 4E10 dramatically reduced 4E10 binding to 10A.3, gp41 and H3A4 (Figure 10B). This suggests that the H3A4 clone does compete with gp41 for binding to 4E10 and may also bind with stronger affinity than gp41. It is also possible that the affinity of gp41 for 4E10 when in solution is not as great as when it is immobilized on a plate. This is supported by the results of the competition of gp41 in solution against gp41 bound to the plate (Figure 10B).

Figure 11 shows the results of the competition ELISA performed with the cyclic clones. The binding to the parental clone E6.8 is not very strong, but is reduced to background upon the addition of gp41 to the Fab. It can be seen that gp41 competed effectively with both optimized cyclic clones for binding to 4E10. Binding to both clone E7G3 and E5E1 was significantly reduced by gp41, though not to background levels. It is possible that this represents a similar situation as with the linear clone H3A4, and these clones bind well enough to 4E10 that it is difficult to completely block binding. However it is also possible that this shows a partial overlap of the binding sites for these peptides and gp41 on 4E10, or that the binding regions for the peptides and gp41 do not overlap at all, but are close enough to each other that binding of one will create a steric hindrance

for the binding of the other. Future analyses will be necessary to determine if this is the case.

Figure 9. Competition ELISA of Optimized Clones from the 10A.3 Doped Library against gp41 for Binding to 4E10 Fab.

Phage clones or gp41 were adsorbed to the wells of a microtiter plate. 4E10 Fab was incubated either with or without gp41 in solution (A) or with or without the phage clone H3A4 (B) prior to addition to the ELISA. OD was read at 405-490 nm.

A

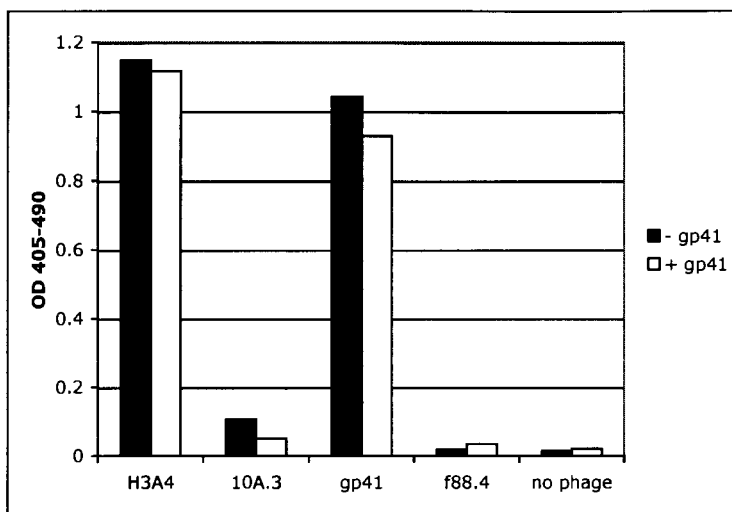

B

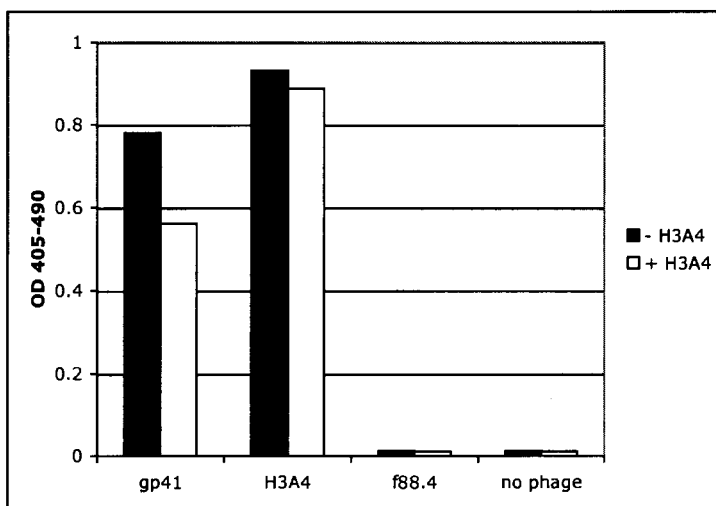
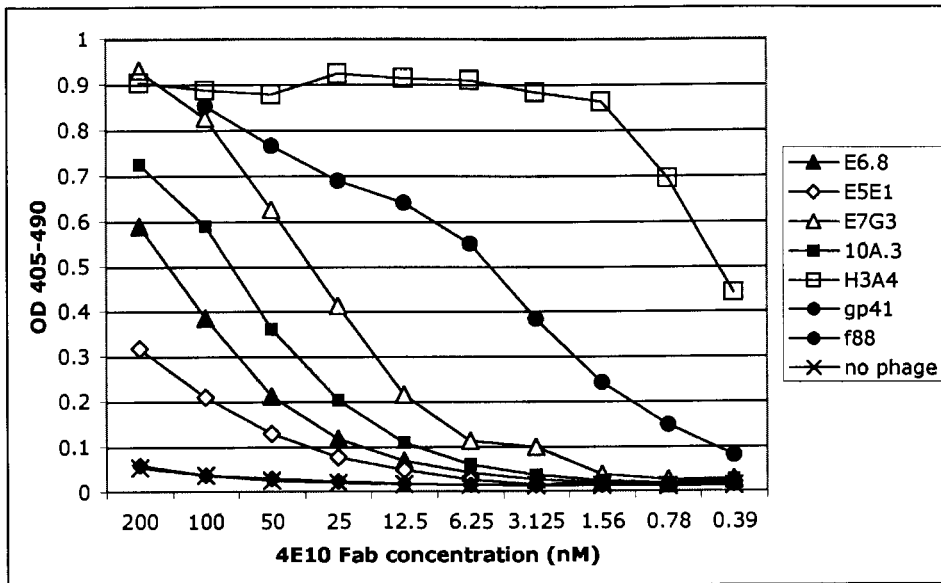

Figure 10. Competition ELISA of the Optimized Clone from the 10A.3 Doped Library against gp41 for Binding to 4E10 Using a Low Antibody Concentration.

(A) Titration of 4E10 Fab on the phage clones and gp41 for the determination of the optimal antibody concentration to be used in competition assays. Phage clones and gp41 were immobilized in the wells of a microtiter plate. (B) Phage clones or gp41 were adsorbed to the wells of a microtiter plate. 4E10 Fab was incubated either with gp41 or the phage clone H3A4 in solution or alone prior to addition to the ELISA. OD was read at 405-490 nm.

A



B

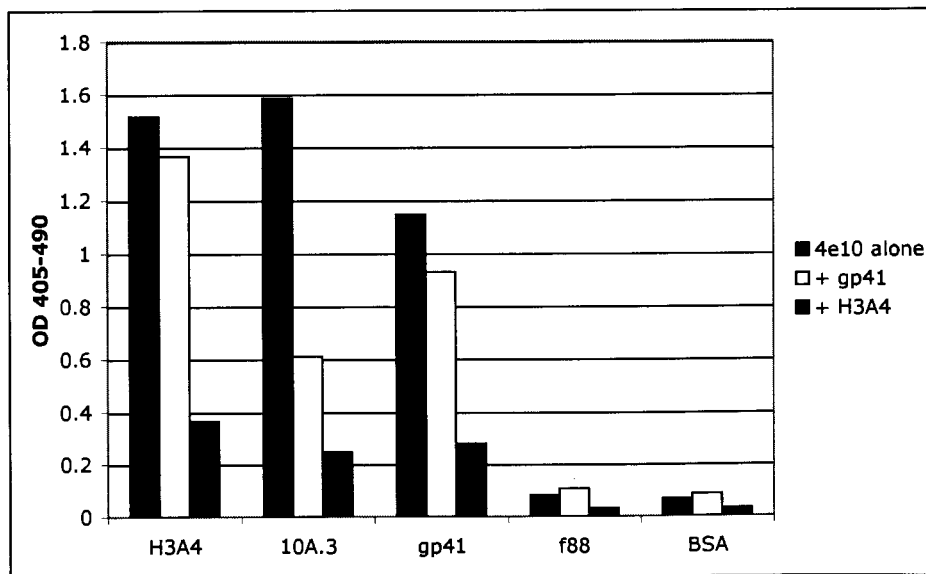
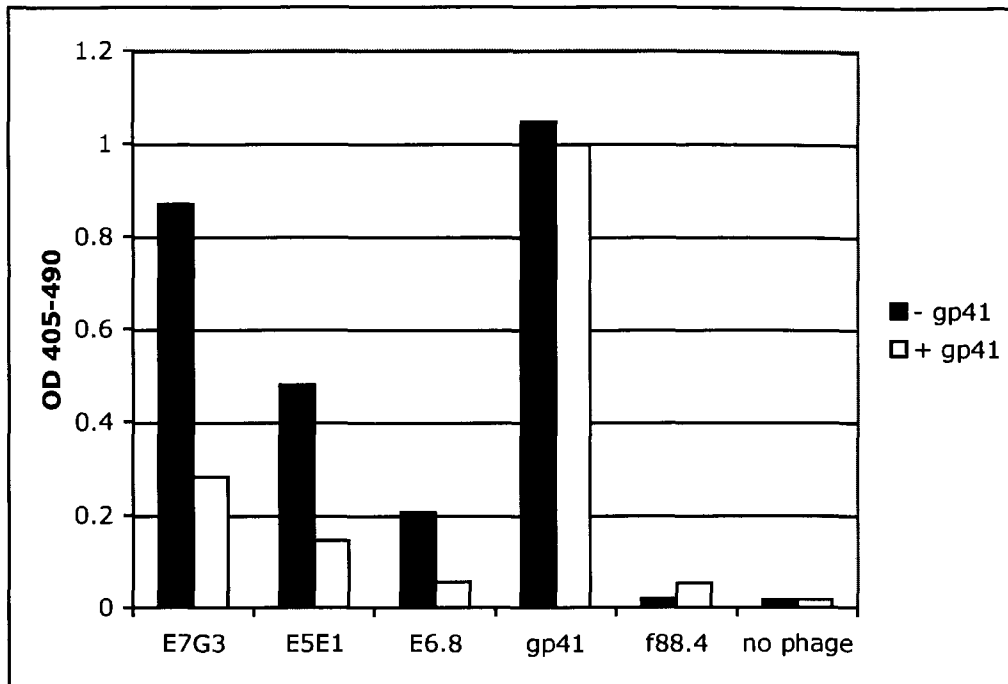

Figure 11. Competition ELISA of Optimized Clones from the E6.8 Doped Library against gp41 for Binding to 4E10 Fab.

Phage clones or gp41 were adsorbed to the wells of a microtiter plate. 4E10 Fab was incubated either with or without gp41 in solution prior to addition to the ELISA. OD was read at 405-490 nm.



4 DISCUSSION

The identification and optimization of two peptides that bind to the broadly HIV-1 neutralizing MAb, 4E10 is presented here. One peptide is a linear mimic of the native epitope of 4E10 on gp41 as defined by the motif NWFDIT (88, 104). The other one is a cyclic peptide bearing little or no homology to the epitope on gp41. The two peptides were selected by 4E10 IgG from the screening of phage-displayed peptide libraries. The optimization of the binding of these peptides to 4E10 was carried out by the construction of two “doped” libraries, which were based on each peptide sequence of the parental clones. The doped libraries contained approximately 10^{10} clones each with a bias favouring the parental peptide sequences, such that for each residue of the peptide, there was a mixture of approximately 50% native amino acid and 50% random amino acid in the library. These libraries were screened with 4E10 IgG and Fab and several clones were identified that were able to bind to 4E10, including many that bound more strongly than the corresponding parental clones (Table 9). Additionally, alignment of the peptide sequences of the clones from the screening of the linear doped library indicated shared residues of the peptides that are presumably important for binding. This consensus sequence aligns with the previously mapped epitope for 4E10 on gp41, and extends beyond that sequence. The cyclic peptide provides an alternative mechanism of binding to 4E10, and as a ligand, may help to reveal its unique structural features.

Table 9. Top Binding Clones Representing the Linear and Constrained Peptides to which 4E10 Binds.

Clone	Peptide Sequence	4E10 binding ^a
10A.3 (parental)	AEPAETSWFYLTTFLL	*
H3A4	AEPAENNWFMLTYFL	*****
H3D1	APPAETNWFNLTYEL	*****
H3A9	AVPRETNWFALTTWL	*****
H3B6	AEPAEVNWFVLTLYFL	*****
H4E3	AEIAETNWFLLTTFLL	*****
gp41 HxB2	ELDKWASLWNWFNITNWLVIK	****
E6.8 (parental)	RCRTIDVFRNCI	*
E7G3	TCQTIDIFRNCI	***
E5E1	RCVQIDVFRNCI	***
E5E11	RCREIDVFRNCI	**
E5C8	RCPTIDIFRNCI	**
E5E4	SCPTIDIFRNCI	**

^aRelative binding based on data from Table 6 and Table 8

4.1 4E10 Binds to a Linear Peptide with Homology to gp41

The epitope for 4E10 was originally mapped to the linear sequence AEGTDRV on the intracellular domain of gp41 corresponding to residues 824-830 of gp160 of the HIV-1 isolate BH10 (11). Consequently, not much interest was taken in this antibody until several years later when another group mapped the epitope to the highly conserved MPR on the extracellular domain of gp41 (104). The minimum-binding region was identified to be the six residue sequence, NWFNIT, spanning residues 670–675 (numbering and sequence corresponds to gp160 of the HIV-1 isolate HxB2); this result was also confirmed by a second group (88). It was believed that the original mapping of the epitope to the intracellular region was due to observed non-specific binding of 4E10 to various antigens at higher concentrations (104). The linear peptide identified here in the original screening of the random peptide libraries contains a consensus, SWFYLT, with the 4E10 viral epitope. It was shown by the screening of the 10A.3 doped library

that this part of the peptide was indeed very important for binding, and a variation of it was found to have appeared in all of the selected clones.

The putative 4E10 epitope is present in the highly conserved MPR of gp41, and is, itself, highly conserved among isolates. An analysis of the sequence conservation of the 4E10 epitope in the 592 sequences contained in the Los Alamos database, shows that the Asn in position one of the epitope is present in 431 isolates (73%). Interestingly, the Ser of the parental 10A.3 peptide was not present in any of the tighter binding clones from the screening of the doped library, and instead an Asn was strongly selected in its place. The WF motif of the native epitope is also highly conserved among HIV-1 isolates (592 and 552 of the 592 isolates, respectively), and also was highly conserved in the clones from the screening, with the WF found in every clone. There is also a Leu found in the clones from the screening in the fifth position of the epitope. Although a Leu was present in only one isolate at this position among those in the database, an Ile was found in 99% (589/592) of sequences in the database. It is possible that the Leu in the peptide is able to play the same role for 4E10 binding as the Ile in the protein due to the fact that they are very similar residues.

The final Thr of the native epitope is also fairly conserved among HIV-1 isolates with 388 of 595 (65%) having a Thr at this position. Of the remaining 207 isolates, 203 have the very similar Ser in place of the Thr. The Thr residue was also completely conserved in the positive clones isolated from the screening, suggesting that it too plays an important role in binding to 4E10. The Asp in position four is the least conserved residue of the native epitope among HIV-1 isolates with 373 isolates (63%) bearing an Asp at this position. The remaining isolates contain a variety of different residues

including Ser, Asn, Gly, and Glu. The residue at this position of the peptide also shows the least conservation among the clones picked from the screening of the doped library. These data support the idea that the WF motif represents the core binding residues in the peptide and in the native viral epitope, and that the Leu or Ile is helping the binding. This is also supported by the recent results presented by Binley *et al.* at the 2004 Keystone Symposia on Molecular Mechanisms of HIV Pathogenesis (6). This group defined the motif WFXI as the minimum core requirement for 4E10 neutralization through their analysis of more than 2500 isolates of M group HIV-1. Additionally, mutagenesis studies of the 4E10 binding region of gp41 have shown the WF motif to be critical for neutralization, with the Ser (of the NWFDIS motif present on the isolate tested) also showing some significance (Michael Zwick, The Scripps Research Institute, personal communication).

The results of the screening of the doped library clearly confirm previous studies identifying the epitope for 4E10 on gp41 as the linear sequence NWFDIT (88, 104); however, they also suggest that portions of gp41 downstream of this six-residue sequence may play a role in binding. The Leu in the position +3 of the NWFXLT motif in the peptides was selected in 95% of clones, and aligns with a Leu residue in gp41 that is also highly conserved in HIV-1 isolates; it is present in all but one of those analyzed. Additionally, there appears to have been selection for either an aromatic residue or a hydrophobic Leu in the +2 position, which aligns with a Trp residue that is conserved in gp41 in 591 of the 592 isolates. Taken together, this suggests that this downstream portion of gp41 is important for optimal binding to 4E10, and indicates expansion of the epitope to NWFNITXWL. Further evidence of this has come from the mutagenesis

studies of gp41 that show that mutating this downstream Trp residue leads to increased resistance to 4E10, however it has not been determined if this is because it affects affinity or epitope exposure (Michael Zwick, personal communication).

Recently, there has been much interest in the MPR of gp41 with regard to its role in membrane fusion. The importance of this region is further emphasized by the fact that two of the most potent, broadly neutralizing MAbs to HIV-1 recognize epitopes within this region. The results from the screening of the linear doped library have demonstrated the importance of the linear sequence of the peptide for binding of 4E10. A similar situation can be seen with the other broadly neutralizing antibody to this region, 2F5. 2F5 recognizes a nine to fifteen residue linear sequence, containing the core sequence, ELDKWA that is found directly N-terminal of the 4E10 epitope (5, 24, 59, 93). It has been determined that the residues DKW are most critical for binding (24, 53, 75) in much the same way as it has been shown here that the WF motif likely makes up the core binding region for 4E10, with the Ile and Thr helping out.

4.2 4E10 Binds to a Constrained Peptide with No Homology to gp41

The identification of the cyclic peptide E6.8, which bears no homology to the 4E10 epitope on gp41, was quite unexpected. This peptide appears to bind to 4E10 as well as the linear clone 10A.3, and yet it is completely unlike it. Although there have been previous examples of the selection from phage-displayed peptide libraries of both linear and constrained peptides by the same antibody, the cyclic clones have always shared some consensus with the linear clones (9, 25, 53, 101). Indeed, this has been the case for 2F5 (53) and has also been demonstrated here by the screenings of the primary libraries with 4E10 by the selection of several cyclic clones having the (S/N)WF motif in

their sequence (Table 2). The E6.8 clone, however, is an exception, having none of this consensus, and yet it was the cyclic clone showing the strongest binding to 4E10.

It is possible that the other cyclic clones that bear the (S/N)WF motif bound to 4E10 to some degree because of this sequence, and that the disulfide bridge formed between the two Cys residues contributed to this binding by adding structure to the peptides. This result suggests that the epitope for 4E10 is not entirely determined by its linear sequence on the MPR of gp41, or that 4E10 has another component to its specificity. X-ray structures of the gp41 peptide and the E6.8 peptide with 4E10 should resolve this question.

The fact that the E6.8 clone, as well as the optimized clones, E7G3 and E5E1, all compete with gp41 for binding to 4E10, suggests that these peptides bind to the 4E10 antigen binding site at least close enough to the site where gp41 binds for gp41 to block their binding. It is quite common for antibodies to cross-react with structurally similar yet distinct antigens, however, it is frequently the case that the cross-reacting antigens make similar contacts with residues in the antigen binding site of the antibody (91), and so it could be expected that a peptide mimic of the protein epitope would incorporate the residues that contribute the strongest interactions with the antibody. However, there are cases in which, although two antigens appear to mimic each other, they may differ quite distinctly in the mechanism of binding (91). An example of this is the mechanism by which the B2.1 peptide binds b12. As mentioned in the introduction, this peptide appears to have homology to gp120. The sequence of the B2.1 peptide aligns with the D loop of gp120, which protrudes from gp120 and fits into a depression formed between CDRs H3, L1 and L3 of b12 (82). Alanine replacement of the residues homologous to the D loop

showed that most of these residues were required for binding of b12 to B2.1 (Saphire, E.O., Montero, M., Menendez, A., Irving, M.B., Parren, P.W.H.I., Burton, D.R., Scott, J.K. and Wilson, I.A., manuscript in preparation). It was thus assumed that these residues made similar contacts with b12 as those on the D loop. However, crystallographic analysis of the peptide bound to b12 revealed that only five of the seven residues that were required for binding to b12 actually contact b12, and further, that of the two residues that contact b12, only one matched with a residue on the D loop of gp120 (Saphire, E.O., Montero, M., Menendez, A., Irving, M.B., Parren, P.W.H.I., Burton, D.R., Scott, J.K. and Wilson, I.A., manuscript in preparation), despite the fact that it binds to the same region of the antigen binding site of b12 as the D loop (82). It was thus concluded that the other residues are likely important for presenting the correct structure of the peptide for binding. It appears that the E6.8 peptide is not mimicking the contact residues of the native gp41 epitope in any obvious way, as it bears no homology to it, but perhaps the constrained nature of this peptide has enabled it to replicate the shape of the binding site in an energetically favourable manner that is distinct from that of 4E10 binding to gp41. Additionally, it was shown by Ofek *et al.* that binding of 4E10 to peptide containing the NWFDIT epitope is enhanced by the presence of lipid, similar to the results of 2F5 discussed in the introduction (64). It is possible that the conformation of the native epitope for 4E10 is stabilized by lipid, increasing the affinity for 4E10; perhaps the E6.8 peptide mimics this. A comparison of the crystal structure of 4E10 bound to E6.8 and to the native gp41 peptide sequence should reveal whether they occupy the same, overlapping or separate sites on the antibody and should further clarify the role of E6.8 as a ligand for 4E10.

4.3 The Mechanism of Neutralization of MAb 4E10 May Closely Resemble that of MAb 2F5

The antibodies 4E10 and 2F5 share many very important characteristics. Both recognize minimal six-residue linear epitopes that are closely situated on the MPR of the extracellular domain of gp41. This region has been shown to be necessary for fusion of the viral membrane to the target cell and thus, necessary for viral infectivity (80). Additionally, both antibodies have demonstrated some reliance of their binding on the conformation of their epitopes in gp41. It is also possible that 2F5 and 4E10 share similar mechanisms for the neutralization of HIV-1. Binley *et al.* showed that 2F5 is most active against the gp41, pre-hairpin intermediate during the fusion process through the use of a disulfide-shackled envelope protein that only proceeds to fusion after reduction of the disulfide bond linking gp120 and gp41 (7). In the same study, it was shown that 4E10 shows neutralizing activity against this intermediate, suggesting that it prevents formation of the fusion active six-helix bundle. Additionally, studies of peptides representing the MPR of gp41, including the entire 4E10 epitope, show that this region interacts with membrane (89) and forms a helical structure in the presence of lipid micelles (85), and is important for membrane perturbation and mixing (89, 90). This suggests that 4E10 neutralization may occur through the inhibition of this step in the fusion process as well.

4.4 Future Studies

A better understanding of the binding characteristics of both the optimized linear and cyclic peptides with 4E10 is desirable. The strong consensus sequences observed among the clones identified from the screening of the two doped libraries indicate the

residues that are most important for binding, and thus more highly conserved among the clones. To confirm these results, alanine scan mutagenesis of the phage clones should be carried out. Each amino acid of the peptide could be mutated to an Ala consecutively, and the binding analyzed. Presumably, those residues required for binding would not tolerate the change to Ala, and so binding would be either significantly reduced or ablated. It would thus be possible to assess the relative contribution to binding of each residue in the peptides.

Another important step in the characterization of these peptides is to determine their binding affinity to 4E10. In order to obtain an accurate determination of affinity, it is necessary to have the peptide displayed in a monovalent manner. Towards this end, the transfer of the two parental peptides in addition to the three optimized peptides to the N-terminus of the maltose binding protein (as described by (102)) has been carried out. It will be possible to use these fusion proteins to determine the affinity of these peptides by surface plasmon resonance. It will also be desirable to obtain synthetic versions of these peptides, to compare the affinities obtained with the synthetic peptides versus those of the corresponding recombinant fusion proteins, as it has been previously observed that affinities for the peptide displayed as a fusion protein is significantly higher than for the synthetic version (101). Additionally, the peptide-protein fusions, as well as the synthetic peptides, can be used in structural studies such as NMR and X-ray crystallography of the peptides when bound to 4E10.

The ultimate goal behind the work presented here was to aid in the development of an antibody-targeted vaccine against HIV-1, and it is expected that the peptides identified here will contribute to this goal. However, before attempting to develop an

antigen for the production of a specific antibody, it is first necessary to determine if it is commonly produced during HIV-1 infection. It is likely that the HIV-1 neutralizing antibodies such as 2F5, b12 or 2G12 are rare, given their unusual characteristics (for example, long H3 and many somatic mutations). Further, it is likely that 4E10 also will prove to be as unusual as these given its similarities to 2F5. However, with the identification of specific peptide markers it is possible to analyze the sera of HIV-1 infected individuals for the production of 4E10 or 4E10-like antibodies. The E6.8 peptide is ideal for such an analysis due to its unique specificity for 4E10. A study of the binding of sera taken from HIV-1 infected individuals at regular time periods over several years has shown that reactivity of the sera with gp41 occurs even at the early stages of infection (Wang, C. and Scott, J.K., manuscript in preparation). This study has shown that a peptide fragment of the MN isolate that includes the 4E10 epitope also shows reactivity with the sera, but to a lesser extent. However, there is no reactivity with the E6.8 peptide, emphasizing its specificity. Thus, it is possible that it will be difficult, if not impossible to elicit 4E10 or 4E10-like antibodies. However the identification and optimization of the two peptides described here, which bind tightly and specifically to 4E10 will lead to a better understanding of this antibody.

REFERENCES

1. 2003. AIDS epidemic update. UNAIDS/WHO.
2. **Amara, A., and D. R. Littman.** 2003. After Hrs with HIV. *J Cell Biol* **162**:371-5.
3. **Baldwin, C. E., R. W. Sanders, and B. Berkhout.** 2003. Inhibiting HIV-1 entry with fusion inhibitors. *Curr Med Chem* **10**:1633-42.
4. **Barbas, C. F., 3rd, T. A. Collet, W. Amberg, P. Roben, J. M. Binley, D. Hoekstra, D. Cababa, T. M. Jones, R. A. Williamson, G. R. Pilkington, N. L. Haigwood, E. Cabezas, A. C. Satterthwait, I. Sanz, and D. R. Burton.** 1993. Molecular profile of an antibody response to HIV-1 as probed by combinatorial libraries. *J Mol Biol* **230**:812-23.
5. **Barbato, G., E. Bianchi, P. Ingallinella, W. H. Hurni, M. D. Miller, G. Ciliberto, R. Cortese, R. Bazzo, J. W. Shiver, and A. Pessi.** 2003. Structural analysis of the epitope of the anti-HIV antibody 2F5 sheds light into its mechanism of neutralization and HIV fusion. *J Mol Biol* **330**:1101-15.
6. **Binley, J., T. Wrin, B. Korbe, M. B. Zwick, C. Chappey, G. Stiegler, R. Kunert, S. Zolla-Pazner, H. Katinger, C. J. Petropoulos, and D. R. Burton.** 2004. Comprehensive cross-clade neutralization analysis of a panel of anti-HIV-1 monoclonal antibodies and a clade B HIV-1 serum. Presented at the Keystone Symposia on Molecular Mechanisms of HIV Pathogenesis, Whistler, BC.
7. **Binley, J. M., C. S. Cayanan, C. Wiley, N. Schulke, W. C. Olson, and D. R. Burton.** 2003. Redox-triggered infection by disulfide-shackled human immunodeficiency virus type 1 pseudovirions. *J Virol* **77**:5678-84.
8. **Binley, J. M., R. W. Sanders, B. Clas, N. Schuelke, A. Master, Y. Guo, F. Kajumo, D. J. Anselma, P. J. Maddon, W. C. Olson, and J. P. Moore.** 2000. A recombinant human immunodeficiency virus type 1 envelope glycoprotein complex stabilized by an intermolecular disulfide bond between the gp120 and gp41 subunits is an antigenic mimic of the trimeric virion-associated structure. *J Virol* **74**:627-43.
9. **Bonnycastle, L. L., J. S. Mehroke, M. Rashed, X. Gong, and J. K. Scott.** 1996. Probing the basis of antibody reactivity with a panel of constrained peptide libraries displayed by filamentous phage. *J Mol Biol* **258**:747-62.
10. **Bonnycastle, L. L., A. Menendez, and J. K. Scott.** 2001. Production of peptide libraries. *In* C. F. Barbas, D. R. Burton, J. K. Scott, and G. J. Silverman (ed.), *Phage Display: A Laboratory Manual*. Cold Spring Harbor Laboratory Press, Cold Spring Harbor.

11. **Buchacher, A., R. Predl, K. Strutzenberger, W. Steinfeldner, A. Trkola, M. Purtscher, G. Gruber, C. Tauer, F. Steindl, A. Jungbauer, and H. Katinger.** 1994. Generation of human monoclonal antibodies against HIV-1 proteins; electrofusion and Epstein-Barr virus transformation for peripheral blood lymphocyte immortalization. *AIDS Res Hum Retroviruses* **10**:359-69.
12. **Burton, D. R., R. C. Desrosiers, R. W. Doms, W. C. Koff, P. D. Kwong, J. P. Moore, G. J. Nabel, J. Sodroski, I. A. Wilson, and R. T. Wyatt.** 2004. HIV vaccine design and the neutralizing antibody problem. *Nat Immunol* **5**:233-6.
13. **Caffrey, M., M. Cai, J. Kaufman, S. J. Stahl, P. T. Wingfield, D. G. Covell, A. M. Gronenborn, and G. M. Clore.** 1998. Three-dimensional solution structure of the 44 kDa ectodomain of SIV gp41. *Embo J* **17**:4572-84.
14. **Calarese, D. A., C. N. Scanlan, M. B. Zwick, S. Deechongkit, Y. Mimura, R. Kunert, P. Zhu, M. R. Wormald, R. L. Stanfield, K. H. Roux, J. W. Kelly, P. M. Rudd, R. A. Dwek, H. Katinger, D. R. Burton, and I. A. Wilson.** 2003. Antibody domain exchange is an immunological solution to carbohydrate cluster recognition. *Science* **300**:2065-71.
15. **Cao, J., L. Bergeron, E. Helseth, M. Thali, H. Repke, and J. Sodroski.** 1993. Effects of amino acid changes in the extracellular domain of the human immunodeficiency virus type 1 gp41 envelope glycoprotein. *J Virol* **67**:2747-55.
16. **Chan, D. C., D. Fass, J. M. Berger, and P. S. Kim.** 1997. Core structure of gp41 from the HIV envelope glycoprotein. *Cell* **89**:263-73.
17. **Chan, D. C., and P. S. Kim.** 1998. HIV entry and its inhibition. *Cell* **93**:681-4.
18. **Chen, X., G. Scala, I. Quinto, W. Liu, T. W. Chun, J. S. Justement, O. J. Cohen, T. C. vanCott, M. Iwanicki, M. G. Lewis, J. Greenhouse, T. Barry, D. Venzon, and A. S. Fauci.** 2001. Protection of rhesus macaques against disease progression from pathogenic SHIV-89.6PD by vaccination with phage-displayed HIV-1 epitopes. *Nat Med* **7**:1225-31.
19. **Cleveland, S. M., E. Buratti, T. D. Jones, P. North, F. Baralle, L. McLain, T. McInerney, Z. Durrani, and N. J. Dimmock.** 2000. Immunogenic and antigenic dominance of a nonneutralizing epitope over a highly conserved neutralizing epitope in the gp41 envelope glycoprotein of human immunodeficiency virus type 1: its deletion leads to a strong neutralizing response. *Virology* **266**:66-78.
20. **Cleveland, S. M., L. McLain, L. Cheung, T. D. Jones, M. Hollier, and N. J. Dimmock.** 2003. A region of the C-terminal tail of the gp41 envelope glycoprotein of human immunodeficiency virus type 1 contains a neutralizing epitope: evidence for its exposure on the surface of the virion. *J Gen Virol* **84**:591-602.
21. **Coeffier, E., J. M. Clement, V. Cussac, N. Khodaei-Boorane, M. Jehanno, M. Rojas, A. Dridi, M. Latour, R. El Habib, F. Barre-Sinoussi, M. Hofnung, and C. Leclerc.** 2000. Antigenicity and immunogenicity of the HIV-1 gp41 epitope ELDKWA inserted into permissive sites of the MalE protein. *Vaccine* **19**:684-93.

22. **Colman, P. M., and M. C. Lawrence.** 2003. The structural biology of type I viral membrane fusion. *Nat Rev Mol Cell Biol* **4**:309-19.
23. **Condra, J. H., M. D. Miller, D. J. Hazuda, and E. A. Emini.** 2002. Potential new therapies for the treatment of HIV-1 infection. *Annu Rev Med* **53**:541-55.
24. **Conley, A. J., J. A. Kessler, 2nd, L. J. Boots, J. S. Tung, B. A. Arnold, P. M. Keller, A. R. Shaw, and E. A. Emini.** 1994. Neutralization of divergent human immunodeficiency virus type 1 variants and primary isolates by IAM-41-2F5, an anti-gp41 human monoclonal antibody. *Proc Natl Acad Sci U S A* **91**:3348-52.
25. **Craig, L., P. C. Sanschagrin, A. Rozek, S. Lackie, L. A. Kuhn, and J. K. Scott.** 1998. The role of structure in antibody cross-reactivity between peptides and folded proteins. *J Mol Biol* **281**:183-201.
26. **Crandall, K. A.** March 2001. Human Immunodeficiency Viruses (HIV), *Nature Encyclopedia of Life Sciences*. Naure Publishing Group, London.
27. **Darbha, R., S. Phogat, A. F. Labrijn, Y. Shu, Y. Gu, M. Andrykovitch, M. Y. Zhang, R. Pantophlet, L. Martin, C. Vita, D. R. Burton, D. S. Dimitrov, and X. Ji.** 2004. Crystal structure of the broadly cross-reactive HIV-1-neutralizing Fab X5 and fine mapping of its epitope. *Biochemistry* **43**:1410-7.
28. **de Rosny, E., R. Vassell, S. Jiang, R. Kunert, and C. D. Weiss.** 2004. Binding of the 2F5 monoclonal antibody to native and fusion-intermediate forms of human immunodeficiency virus type 1 gp41: implications for fusion-inducing conformational changes. *J Virol* **78**:2627-31.
29. **Eckert, D. M., and P. S. Kim.** 2001. Mechanisms of viral membrane fusion and its inhibition. *Annu Rev Biochem* **70**:777-810.
30. **Eckhart, L., W. Raffelsberger, B. Ferko, A. Klima, M. Purtscher, H. Katinger, and F. Ruker.** 1996. Immunogenic presentation of a conserved gp41 epitope of human immunodeficiency virus type 1 on recombinant surface antigen of hepatitis B virus. *J Gen Virol* **77** (Pt 9):2001-8.
31. **Ferrantelli, F., R. Hofmann-Lehmann, R. A. Rasmussen, T. Wang, W. Xu, P. L. Li, D. C. Montefiori, L. A. Cavacini, H. Katinger, G. Stiegler, D. C. Anderson, H. M. McClure, and R. M. Ruprecht.** 2003. Post-exposure prophylaxis with human monoclonal antibodies prevented SHIV89.6P infection or disease in neonatal macaques. *Aids* **17**:301-9.
32. **Freed, E. O.** 2001. HIV-1 replication. *Somat Cell Mol Genet* **26**:13-33.
33. **Gallo, S. A., C. M. Finnegan, M. Viard, Y. Raviv, A. Dimitrov, S. S. Rawat, A. Puri, S. Durell, and R. Blumenthal.** 2003. The HIV Env-mediated fusion reaction. *Biochim Biophys Acta* **1614**:36-50.
34. **Glaser, S. M., D. E. Yelton, and W. D. Huse.** 1992. Antibody engineering by codon-based mutagenesis in a filamentous phage vector system. *J Immunol* **149**:3903-13.
35. **Gorny, M. K., A. J. Conley, S. Karwowska, A. Buchbinder, J. Y. Xu, E. A. Emini, S. Koenig, and S. Zolla-Pazner.** 1992. Neutralization of diverse human

- immunodeficiency virus type 1 variants by an anti-V3 human monoclonal antibody. *J Virol* **66**:7538-42.
36. **Gorny, M. K., and S. Zolla-Pazner.** 2000. Recognition by human monoclonal antibodies of free and complexed peptides representing the prefusogenic and fusogenic forms of human immunodeficiency virus type 1 gp41. *J Virol* **74**:6186-92.
 37. **Grundner, C., T. Mirzabekov, J. Sodroski, and R. Wyatt.** 2002. Solid-phase proteoliposomes containing human immunodeficiency virus envelope glycoproteins. *J Virol* **76**:3511-21.
 38. **Helseth, E., U. Olshevsky, D. Gabuzda, B. Ardman, W. Haseltine, and J. Sodroski.** 1990. Changes in the transmembrane region of the human immunodeficiency virus type 1 gp41 envelope glycoprotein affect membrane fusion. *J Virol* **64**:6314-8.
 39. **Hunter, E.** 1997. gp41, a multifunctional protein involved in HIV entry and pathogenesis. *The Human Retroviruses and AIDS 1997 Compendium*:III-55-73.
 40. **Johnson, W. E., and R. C. Desrosiers.** 2002. Viral persistence: HIV's strategies of immune system evasion. *Annu Rev Med* **53**:499-518.
 41. **Joyce, J. G., W. M. Hurni, M. J. Bogusky, V. M. Garsky, X. Liang, M. P. Citron, R. C. Danzeisen, M. D. Miller, J. W. Shiver, and P. M. Keller.** 2002. Enhancement of alpha -helicity in the HIV-1 inhibitory peptide DP178 leads to an increased affinity for human monoclonal antibody 2F5 but does not elicit neutralizing responses in vitro. Implications for vaccine design. *J Biol Chem* **277**:45811-20.
 42. **Kapoor, A., and S. N. Vani.** 2004. Prevention of mother to child transmission of HIV. *Indian J Pediatr* **71**:247-51.
 43. **Kitabwalla, M., F. Ferrantelli, T. Wang, A. Chalmers, H. Katinger, G. Stiegler, L. A. Cavacini, T. C. Chou, and R. M. Ruprecht.** 2003. Primary African HIV clade A and D isolates: effective cross-clade neutralization with a quadruple combination of human monoclonal antibodies raised against clade B. *AIDS Res Hum Retroviruses* **19**:125-31.
 44. **Labriijn, A. F., P. Poignard, A. Raja, M. B. Zwick, K. Delgado, M. Franti, J. Binley, V. Vivona, C. Grundner, C. C. Huang, M. Venturi, C. J. Petropoulos, T. Wrin, D. S. Dimitrov, J. Robinson, P. D. Kwong, R. T. Wyatt, J. Sodroski, and D. R. Burton.** 2003. Access of antibody molecules to the conserved coreceptor binding site on glycoprotein gp120 is sterically restricted on primary human immunodeficiency virus type 1. *J Virol* **77**:10557-65.
 45. **Letvin, N. L., D. H. Barouch, and D. C. Montefiori.** 2002. Prospects for vaccine protection against HIV-1 infection and AIDS. *Annu Rev Immunol* **20**:73-99.
 46. **Markosyan, R. M., F. S. Cohen, and G. B. Melikyan.** 2003. HIV-1 Envelope Proteins Complete Their Folding into Six-helix Bundles Immediately after Fusion Pore Formation. *Mol Biol Cell* **14**:926-38.

47. **Mascola, J. R.** 2002. Passive transfer studies to elucidate the role of antibody-mediated protection against HIV-1. *Vaccine* **20**:1922-5.
48. **Mascola, J. R., M. G. Lewis, G. Stiegler, D. Harris, T. C. VanCott, D. Hayes, M. K. Louder, C. R. Brown, C. V. Sapan, S. S. Frankel, Y. Lu, M. L. Robb, H. Katinger, and D. L. Birx.** 1999. Protection of Macaques against pathogenic simian/human immunodeficiency virus 89.6PD by passive transfer of neutralizing antibodies. *J Virol* **73**:4009-18.
49. **Mascola, J. R., G. Stiegler, T. C. VanCott, H. Katinger, C. B. Carpenter, C. E. Hanson, H. Beary, D. Hayes, S. S. Frankel, D. L. Birx, and M. G. Lewis.** 2000. Protection of macaques against vaginal transmission of a pathogenic HIV-1/SIV chimeric virus by passive infusion of neutralizing antibodies. *Nat Med* **6**:207-10.
50. **McGaughey, G. B., M. Citron, R. C. Danzeisen, R. M. Freidinger, V. M. Garsky, W. M. Hurni, J. G. Joyce, X. Liang, M. Miller, J. Shiver, and M. J. Bogusky.** 2003. HIV-1 vaccine development: constrained peptide immunogens show improved binding to the anti-HIV-1 gp41 MAb. *Biochemistry* **42**:3214-23.
51. **Melikyan, G. B., R. M. Markosyan, H. Hemmati, M. K. Delmedico, D. M. Lambert, and F. S. Cohen.** 2000. Evidence that the transition of HIV-1 gp41 into a six-helix bundle, not the bundle configuration, induces membrane fusion. *J Cell Biol* **151**:413-23.
52. **Menendez, A., L. L. Bonnycastle, O. C. C. Pan, and J. K. Scott.** 2001. Screening peptide libraries. *In* C. F. Barbas, D. R. Burton, J. K. Scott, and G. J. Silverman (ed.), *Phage Display: A Laboratory Manual*. Cold Spring Harbor Laboratory Press, Cold Spring Harbor.
53. **Menendez, A., K. C. Chow, O. C. Pan, and J. K. Scott.** 2004. Human immunodeficiency virus type 1-neutralizing monoclonal antibody 2F5 is multispecific for sequences flanking the DKW core epitope. *J Mol Biol* **338**:311-27.
54. **Model, P., and M. Russel.** 1988. Filamentous Bacteriophage, p. 375 - 456. *In* R. Calendar (ed.), *The Bacteriophages*, vol. 2. Plenum Publishing Corporation.
55. **Moore, J. P., S. G. Kitchen, P. Pugach, and J. A. Zack.** 2004. The CCR5 and CXCR4 coreceptors--central to understanding the transmission and pathogenesis of human immunodeficiency virus type 1 infection. *AIDS Res Hum Retroviruses* **20**:111-26.
56. **Morrissey, J. H.** 1981. Silver stain for proteins in polyacrylamide gels: a modified procedure with enhanced uniform sensitivity. *Anal Biochem* **117**:307-10.
57. **Moulard, M., S. K. Phogat, Y. Shu, A. F. Labrijn, X. Xiao, J. M. Binley, M. Y. Zhang, I. A. Sidorov, C. C. Broder, J. Robinson, P. W. Parren, D. R. Burton, and D. S. Dimitrov.** 2002. Broadly cross-reactive HIV-1-neutralizing human monoclonal Fab selected for binding to gp120-CD4-CCR5 complexes. *Proc Natl Acad Sci U S A* **99**:6913-8.

58. **Muster, T., R. Guinea, A. Trkola, M. Purtscher, A. Klima, F. Steindl, P. Palese, and H. Katinger.** 1994. Cross-neutralizing activity against divergent human immunodeficiency virus type 1 isolates induced by the gp41 sequence ELDKWAS. *J Virol* **68**:4031-4.
59. **Muster, T., F. Steindl, M. Purtscher, A. Trkola, A. Klima, G. Himmler, F. Ruker, and H. Katinger.** 1993. A conserved neutralizing epitope on gp41 of human immunodeficiency virus type 1. *J Virol* **67**:6642-7.
60. **Mwau, M., and A. J. McMichael.** 2003. A review of vaccines for HIV prevention. *J Gene Med* **5**:3-10.
61. **Nabel, G. J.** 2001. Challenges and opportunities for development of an AIDS vaccine. *Nature* **410**:1002-7.
62. **Nguyen, D. G., A. Booth, S. J. Gould, and J. E. Hildreth.** 2003. Evidence that HIV budding in primary macrophages occurs through the exosome release pathway. *J Biol Chem* **278**:52347-54.
63. **Nydegger, S., M. Foti, A. Derdowski, P. Spearman, and M. Thali.** 2003. HIV-1 egress is gated through late endosomal membranes. *Traffic* **4**:902-10.
64. **Ofek, G., M. Tang, A. Sambor, H. Katinger, J. R. Mascola, R. Wyatt, and P. D. Kwong.** Structure and mechanistic analysis of the anti-HIV-1 antibody 2F5 in complex with its gp41 epitope. *J Virol*, in press.
65. **Pai, E. F., M. Klein, P. Chong, and A. Pedyczak.** 2000. Fab'-epitope complex from the HIV-1 cross-neutralizing monoclonal antibody 2F5. Patent WO-00/61618. World Intellectual Property Organization.
66. **Pantaleo, G., C. Graziosi, and A. S. Fauci.** 1993. New concepts in the immunopathogenesis of human immunodeficiency virus infection. *N Engl J Med* **328**:327-35.
67. **Pantophlet, R., and D. R. Burton.** 2003. Immunofocusing: antigen engineering to promote the induction of HIV-neutralizing antibodies. *Trends Mol Med* **9**:468-73.
68. **Pantophlet, R., E. Ollmann Saphire, P. Poignard, P. W. Parren, I. A. Wilson, and D. R. Burton.** 2003. Fine mapping of the interaction of neutralizing and nonneutralizing monoclonal antibodies with the CD4 binding site of human immunodeficiency virus type 1 gp120. *J Virol* **77**:642-58.
69. **Pantophlet, R., I. A. Wilson, and D. R. Burton.** 2003. Hyperglycosylated mutants of human immunodeficiency virus (HIV) type 1 monomeric gp120 as novel antigens for HIV vaccine design. *J Virol* **77**:5889-901.
70. **Parker, C. E., L. J. Deterding, C. Hager-Braun, J. M. Binley, N. Schulke, H. Katinger, J. P. Moore, and K. B. Tomer.** 2001. Fine definition of the epitope on the gp41 glycoprotein of human immunodeficiency virus type 1 for the neutralizing monoclonal antibody 2F5. *J Virol* **75**:10906-11.

71. **Parren, P. W., J. P. Moore, D. R. Burton, and Q. J. Sattentau.** 1999. The neutralizing antibody response to HIV-1: viral evasion and escape from humoral immunity. *Aids* **13 Suppl A**:S137-62.
72. **Peisajovich, S. G., L. Blank, R. F. Epand, R. M. Epand, and Y. Shai.** 2003. On the interaction between gp41 and membranes: the immunodominant loop stabilizes gp41 helical hairpin conformation. *J Mol Biol* **326**:1489-501.
73. **Peterlin, B. M., and D. Trono.** 2003. Hide, shield and strike back: how HIV-infected cells avoid immune eradication. *Nat Rev Immunol* **3**:97-107.
74. **Poumbourios, P., W. el Ahmar, D. A. McPhee, and B. E. Kemp.** 1995. Determinants of human immunodeficiency virus type 1 envelope glycoprotein oligomeric structure. *J Virol* **69**:1209-18.
75. **Purtscher, M., A. Trkola, A. Grassauer, P. M. Schulz, A. Klima, S. Dopfer, G. Gruber, A. Buchacher, T. Muster, and H. Katinger.** 1996. Restricted antigenic variability of the epitope recognized by the neutralizing gp41 antibody 2F5. *Aids* **10**:587-93.
76. **Purtscher, M., A. Trkola, G. Gruber, A. Buchacher, R. Predl, F. Steindl, C. Tauer, R. Berger, N. Barrett, A. Jungbauer, and H. Katinger.** 1994. A broadly neutralizing human monoclonal antibody against gp41 of human immunodeficiency virus type 1. *AIDS Res Hum Retroviruses* **10**:1651-8.
77. **Richman, D. D., T. Wrin, S. J. Little, and C. J. Petropoulos.** 2003. Rapid evolution of the neutralizing antibody response to HIV type 1 infection. *Proc Natl Acad Sci U S A* **100**:4144-9.
78. **Roben, P., J. P. Moore, M. Thali, J. Sodroski, C. F. Barbas, 3rd, and D. R. Burton.** 1994. Recognition properties of a panel of human recombinant Fab fragments to the CD4 binding site of gp120 that show differing abilities to neutralize human immunodeficiency virus type 1. *J Virol* **68**:4821-8.
79. **Ruprecht, R. M., F. Ferrantelli, M. Kitabwalla, W. Xu, and H. M. McClure.** 2003. Antibody protection: passive immunization of neonates against oral AIDS virus challenge. *Vaccine* **21**:3370-3.
80. **Salzwedel, K., J. T. West, and E. Hunter.** 1999. A conserved tryptophan-rich motif in the membrane-proximal region of the human immunodeficiency virus type 1 gp41 ectodomain is important for Env-mediated fusion and virus infectivity. *J Virol* **73**:2469-80.
81. **Sanders, R. W., M. Venturi, L. Schiffner, R. Kalyanaraman, H. Katinger, K. O. Lloyd, P. D. Kwong, and J. P. Moore.** 2002. The mannose-dependent epitope for neutralizing antibody 2G12 on human immunodeficiency virus type 1 glycoprotein gp120. *J Virol* **76**:7293-305.
82. **Saphire, E. O., P. W. Parren, R. Pantophlet, M. B. Zwick, G. M. Morris, P. M. Rudd, R. A. Dwek, R. L. Stanfield, D. R. Burton, and I. A. Wilson.** 2001. Crystal structure of a neutralizing human IGG against HIV-1: a template for vaccine design. *Science* **293**:1155-9.

83. **Scanlan, C. N., R. Pantophlet, M. R. Wormald, E. Ollmann Saphire, R. Stanfield, I. A. Wilson, H. Katinger, R. A. Dwek, P. M. Rudd, and D. R. Burton.** 2002. The broadly neutralizing anti-human immunodeficiency virus type 1 antibody 2G12 recognizes a cluster of alpha1-->2 mannose residues on the outer face of gp120. *J Virol* **76**:7306-21.
84. **Schagger, H., and G. von Jagow.** 1987. Tricine-sodium dodecyl sulfate-polyacrylamide gel electrophoresis for the separation of proteins in the range from 1 to 100 kDa. *Anal Biochem* **166**:368-79.
85. **Schibli, D. J., R. C. Montelaro, and H. J. Vogel.** 2001. The membrane-proximal tryptophan-rich region of the HIV glycoprotein, gp41, forms a well-defined helix in dodecylphosphocholine micelles. *Biochemistry* **40**:9570-8.
86. **Smith, G. P., and J. K. Scott.** 1993. Libraries of peptides and proteins displayed on filamentous phage. *Methods Enzymol* **217**:228-57.
87. **Stanfield, R. L., M. K. Gorny, C. Williams, S. Zolla-Pazner, and I. A. Wilson.** 2004. Structural rationale for the broad neutralization of HIV-1 by human monoclonal antibody 447-52D. *Structure (Camb)* **12**:193-204.
88. **Stiegler, G., R. Kunert, M. Purtscher, S. Wolbank, R. Voglauer, F. Steindl, and H. Katinger.** 2001. A potent cross-clade neutralizing human monoclonal antibody against a novel epitope on gp41 of human immunodeficiency virus type 1. *AIDS Res Hum Retroviruses* **17**:1757-65.
89. **Suarez, T., W. R. Gallaher, A. Agirre, F. M. Goni, and J. L. Nieva.** 2000. Membrane interface-interacting sequences within the ectodomain of the human immunodeficiency virus type 1 envelope glycoprotein: putative role during viral fusion. *J Virol* **74**:8038-47.
90. **Suarez, T., S. Nir, F. M. Goni, A. Saez-Cirion, and J. L. Nieva.** 2000. The pre-transmembrane region of the human immunodeficiency virus type-1 glycoprotein: a novel fusogenic sequence. *FEBS Lett* **477**:145-9.
91. **Sundberg, E. J., and R. A. Mariuzza.** 2002. Molecular recognition in antibody-antigen complexes. *Adv Protein Chem* **61**:119-60.
92. **Tan, K., J. Liu, J. Wang, S. Shen, and M. Lu.** 1997. Atomic structure of a thermostable subdomain of HIV-1 gp41. *Proc Natl Acad Sci U S A* **94**:12303-8.
93. **Tian, Y., C. V. Ramesh, X. Ma, S. Naqvi, T. Patel, T. Cenizal, M. Tiscione, K. Diaz, T. Crea, E. Arnold, G. F. Arnold, and J. W. Taylor.** 2002. Structure-affinity relationships in the gp41 ELDKWA epitope for the HIV-1 neutralizing monoclonal antibody 2F5: effects of side-chain and backbone modifications and conformational constraints. *J Pept Res* **59**:264-76.
94. **Webster, R.** 2001. Filamentous Phage Biology. *In* C. F. Barbas, D. R. Burton, J. K. Scott, and G. J. Silverman (ed.), *Phage Display: A Laboratory Manual*. Cold Spring Harbor Laboratory Press, Cold Spring Harbor.
95. **Wei, X., J. M. Decker, S. Wang, H. Hui, J. C. Kappes, X. Wu, J. F. Salazar-Gonzalez, M. G. Salazar, J. M. Kilby, M. S. Saag, N. L. Komarova, M. A.**

- Nowak, B. H. Hahn, P. D. Kwong, and G. M. Shaw. 2003. Antibody neutralization and escape by HIV-1. *Nature* **422**:307-12.
96. Weiss, R. A. 2001. Gulliver's travels in HIVland. *Nature* **410**:963-7.
97. Weissenhorn, W., A. Dessen, S. C. Harrison, J. J. Skehel, and D. C. Wiley. 1997. Atomic structure of the ectodomain from HIV-1 gp41. *Nature* **387**:426-30.
98. Wyatt, R., and J. Sodroski. 1998. The HIV-1 envelope glycoproteins: fusogens, antigens, and immunogens. *Science* **280**:1884-8.
99. Xu, W., B. A. Smith-Franklin, P. L. Li, C. Wood, J. He, Q. Du, G. J. Bhat, C. Kankasa, H. Katinger, L. A. Cavacini, M. R. Posner, D. R. Burton, T. C. Chou, and R. M. Ruprecht. 2001. Potent neutralization of primary human immunodeficiency virus clade C isolates with a synergistic combination of human monoclonal antibodies raised against clade B. *J Hum Virol* **4**:55-61.
100. Zolla-Pazner, S. 2004. Identifying epitopes of HIV-1 that induce protective antibodies. *Nat Rev Immunol* **4**:199-210.
101. Zwick, M. B., L. L. Bonnycastle, A. Menendez, M. B. Irving, C. F. Barbas, 3rd, P. W. Parren, D. R. Burton, and J. K. Scott. 2001. Identification and characterization of a peptide that specifically binds the human, broadly neutralizing anti-human immunodeficiency virus type 1 antibody b12. *J Virol* **75**:6692-9.
102. Zwick, M. B., L. L. Bonnycastle, K. A. Noren, S. Venturini, E. Leong, C. F. Barbas, 3rd, C. J. Noren, and J. K. Scott. 1998. The maltose-binding protein as a scaffold for monovalent display of peptides derived from phage libraries. *Anal Biochem* **264**:87-97.
103. Zwick, M. B., H. K. Komori, R. L. Stanfield, S. Church, M. Wang, P. W. Parren, R. Kunert, H. Katinger, I. A. Wilson, and D. R. Burton. 2004. The long third complementarity-determining region of the heavy chain is important in the activity of the broadly neutralizing anti-human immunodeficiency virus type 1 antibody 2F5. *J Virol* **78**:3155-61.
104. Zwick, M. B., A. F. Labrijn, M. Wang, C. Spenlehauer, E. O. Saphire, J. M. Binley, J. P. Moore, G. Stiegler, H. Katinger, D. R. Burton, and P. W. Parren. 2001. Broadly neutralizing antibodies targeted to the membrane-proximal external region of human immunodeficiency virus type 1 glycoprotein gp41. *J Virol* **75**:10892-905.
105. Zwick, M. B., A. Menendez, L. L. Bonnycastle, and J. K. Scott. 2001. Analysis of phage-borne peptides. *In* C. F. Barbas, D. R. Burton, J. K. Scott, and G. J. Silverman (ed.), *Phage Display: A Laboratory Manual*. Cold Spring Harbor Laboratory Press, Cold Spring Harbor.
106. Zwick, M. B., J. Shen, and J. K. Scott. 2000. Homodimeric peptides displayed by the major coat protein of filamentous phage. *J Mol Biol* **300**:307-20.
107. Zwick, M. B., M. Wang, P. Poignard, G. Stiegler, H. Katinger, D. R. Burton, and P. W. Parren. 2001. Neutralization synergy of human immunodeficiency

virus type 1 primary isolates by cocktails of broadly neutralizing antibodies. *J Virol* **75**:12198-208.