

**A TEACHING INNOVATION TO PROMOTE  
AUTHENTIC SCIENCE IN A PHYSICS TEACHING  
LABORATORY IN A VIETNAMESE UNIVERSITY**

by

**Ho Huu Hau**

B.Sc., Cantho University, 1981

THESIS SUBMITTED IN PARTIAL FULFILLMENT OF  
THE REQUIREMENTS FOR THE DEGREE OF  
MASTER OF SCIENCE

in the Faculty

of

Education

© Ho Huu Hau 1997

SIMON FRASER UNIVERSITY

April 1997

All rights reserved. This work may not be  
reproduced in whole or in part, by photocopy  
or other means, without permission of the author.



National Library  
of Canada

Acquisitions and  
Bibliographic Services

395 Wellington Street  
Ottawa ON K1A 0N4  
Canada

Bibliothèque nationale  
du Canada

Acquisitions et  
services bibliographiques

395, rue Wellington  
Ottawa ON K1A 0N4  
Canada

*Your file* *Votre référence*

*Our file* *Notre référence*

The author has granted a non-exclusive licence allowing the National Library of Canada to reproduce, loan, distribute or sell copies of this thesis in microform, paper or electronic formats.

The author retains ownership of the copyright in this thesis. Neither the thesis nor substantial extracts from it may be printed or otherwise reproduced without the author's permission.

L'auteur a accordé une licence non exclusive permettant à la Bibliothèque nationale du Canada de reproduire, prêter, distribuer ou vendre des copies de cette thèse sous la forme de microfiche/film, de reproduction sur papier ou sur format électronique.

L'auteur conserve la propriété du droit d'auteur qui protège cette thèse. Ni la thèse ni des extraits substantiels de celle-ci ne doivent être imprimés ou autrement reproduits sans son autorisation.

0-612-24155-6

Canada

## APPROVAL

**NAME**                   Hau Ho Huu  
**DEGREE**                Master of Science  
**TITLE**                   A Teaching Innovation to Promote Authentic Science  
                              in a Physics Teaching Laboratory in a Vietnamese  
                              University

### EXAMINING COMMITTEE:

**Chair**                   Mike Manley-Casimir

---

Allan MacKinnon, Associate Professor  
Senior Supervisor

---

Marvin Wideen, Professor  
Member

---

Michael Wortis, Professor, Department of Physics,  
Simon Fraser University  
Examiner

**Date:**     April 15, 1997

## Abstract

This study investigates learning in a physics teaching laboratory in terms of Donald Schön's analysis of reflection-in-action. The "technical rationalist" view of learning has been criticized as inappropriate for making sense of learning through the activity of doing science. The intent of this study was to develop a teaching innovation using a problem-solving approach to conceptualize and promote authentic science in the physics teaching laboratory.

A case study design was adopted for this work. An electrical experiment was designed and implemented at Cantho University in Vietnam. Participants were two groups of science sophomores undertaking a physics lab course.

Laboratory sessions were videotaped and analyzed in terms of Schön's scheme. A student survey was developed to determine students' opinions about the teaching innovation. Further information was sought through interviewing several students. Thus, the data source for this study included videotapes, interviews, and surveys.

The core of this study is to develop a reflective learning cycle using Schön's conceptualization of reflection-in-action for promoting authentic science. The findings show that students made up problems of their own interest in dealing with the physics problems. In contrast to traditional teaching laboratories in Vietnam, students were flexible in dealing with the problems that arose in their inquiry. The students felt free to design experiments needed for their investigation of physics. They reflected on surprising events to shape their understandings of the phenomena, constructed new meanings of concepts, and developed practical knowledge during laboratory activities.

## **Dedication**

This thesis is dedicated to

my father

**Ho Thanh Tong**

to my mother

**Trang Thi Mang**

and to my sister

**Ho Thi Sau**

## Acknowledgments

I am overwhelmed by the careful guidance, generous advices, and encouragement I receive from Dr. Allan MacKinnon, without whom this work could not have been completed.

I am very grateful to Dr. Marvin Wideen for his interest and enthusiasm in this study, and for the many times he offered helpful advice.

I am also indebted to Glenn Brown and the science education graduate students in Simon Fraser University, who provided the opportunity for me to present and discuss some ideas presented here.

Special thanks to Dr. Michael Wortis for his involvement in this study.

I would like to express my appreciation to Sandra Sachs for her care and support my studies in Canada.

Many thanks to all my friends at Simon Fraser University for their help during my time in Canada. I also acknowledge the class of second year science students who were most cooperative at the time of my data collection in Vietnam.

Finally, I wish to thank Dr. Tran Phuoc Duong, Mr. Dang Van Ba, Dr. Tran Thuong Tuan, Dr. Nguyen Thanh Dao, Dr. Le Phuoc Loc, and Mr. Dinh Thanh Hoa, without whom my study in Canada would have been nearly impossible.

# Table of Contents

Approval.....	ii
Abstract.....	iii
Dedication.....	iv
Acknowledgments.....	v
<b>1. Focus of the study.....</b>	<b>1</b>
The problem statement and the research questions.....	1
Justification for the study.....	2
The context for the study.....	3
Significance of the study.....	5
Data gathering and analysis.....	6
A preview of the study.....	6
<b>2. Review of related literature.....</b>	<b>8</b>
Position statements.....	8
The view of Technical Rationality on learning science.....	9
Criticisms of the Technical Rationalist view of learning science.....	11
Promoting authentic science.....	13
Physics knowledge.....	15
Studies about problem-solving approach in authentic context.....	16
Summary.....	18

<b>3. Theoretical framework</b> .....	19
Reflection-in-action .....	19
Summary .....	23
<b>4. Analysis of the data</b> .....	25
Methodology .....	25
Data collection .....	27
Data analysis .....	29
Phase I: Initial problem-setting .....	30
Phase II: Reframing .....	30
Phase III: Resolve .....	31
Analysis .....	31
The reflective learning cycle .....	31
Phase I: Problem Setting .....	34
Reframing the problem .....	36
The resolve .....	46
Students' thoughts about learning .....	47
Traditional learning science .....	47
Learning by doing science .....	48
Reflective learners .....	50
Students' thoughts about science .....	50
Declarative aspect .....	51
Practical aspect .....	51
Practice versus science as a body of knowledge .....	53
Summary .....	55



<b>5. Conclusions and discussion</b> .....	56
Review of the argument .....	56
Conclusions.....	56
Limitations .....	60
Implications for practice .....	60
Implications for further research.....	61
Bibliography .....	62
Appendix I .....	66
Appendix II .....	70
Appendix III .....	79
Appendix IV .....	90

# Chapter 1

## Focus of the study

### The problem statement and the research questions

The focus of this study is to develop a teaching innovation using a problem-solving approach derived from Donald Schön's analysis of reflection-in-action to promote authentic science in a physics lab course at Cantho University. This study involves a case study of learning events in which science students learn to apply science concepts to solve problems related to their electrical experiments. The technical term for the particular kind of learning the researcher sought is "reflection-in-action," conceptualized by Donald Schön (1983) as a framework for learning in practice. The purpose of the research is to determine whether Schön's conceptualization of reflection-in-action is applicable and appropriate for studying the way in which science students solve physics problems and perform lab activities designed to promote "authentic science." Beyond searching for an adequate representation of learning in the practise setting, the study investigates students' thoughts after the lab course by asking what is the effect of this teaching approach on students' attitudes about learning and science? Interviews with eight students and a survey of seventeen students have been examined.

At first glance, the term "authentic science" may seem self-evident, as meaning "science as it happens within the context of practising scientists' laboratories." Indeed, many authors use the term this way in the science education literature (e.g., Roth, 1993). On closer examination, however, one may consider the idea of "authentic science" to be a myth—that there is no single correct view of what makes any scientific activity "authentic." In this thesis the term "authentic" is used to signify an attempt to develop teaching practices and a view of learning that departs significantly from what is regarded as *inauthentic* practices in physics laboratories in Vietnam, by virtue of the fact that there is currently much reliance on rote

memorization and verification laboratories. In short, this thesis explores the general problem of fostering, and making sense of, meaningful, "active learning" in Vietnamese students of physics.

### **Justification for the study**

Since 1990, several changes have influenced Vietnam's educational system. The former Ministry of Education, the General Department for Vocational Training, and the Ministry of Higher and Secondary Technical Education were reunited as one "Ministry of Education and Training" (Bo Giao Duc va Dao Tao) in 1990. It is recognized that the first five years after the reunification of Vietnam in 1975 were marked by a severe shortage of well qualified people in the general work force and few resources for education (World Education Service, 1994). Even though the government has undertaken enormous efforts to alleviate illiteracy, there remain some persistent problems in the remote mountain areas and in the Mekong Delta, where there are inadequate schools and a shortage of teachers.

The national program to upgrade the educational system led to the development of a plan in 1990 to restructure post-secondary science education in Vietnam and to the formation of a consortium of eleven universities aimed at undertaking the required science curriculum development and teacher education. The broad intention of this plan is to establish a "University Credit System," which includes two phases of work for undergraduate students of science. The first phase is a "basic science" component which will be taught in community colleges across the country. After two years of study in this basic science program, students will transfer into university for the second phase of their education—the science specialization (fisheries, agriculture, engineering, etc.). In principle, this University Credit System will provide improved access to a basic science education, particularly in the more remote areas of the country, and to a solid foundation for further study of science in applied contexts.

While the broad purpose for this restructuring is to increase access to a basic science education and, therefore, to improve the scientific and technological literacy of the Vietnamese citizenry, there are many problems and conditions that help to shape the specific nature of the impending reform. Vietnam has been somewhat isolated from the professional science and science education communities for the past twenty years, and textbooks and teaching methods reflecting current understandings in science are lacking. The condition of teaching laboratories is very poor in certain areas of the country, and this, in part, has led to a rather "rhetorical" science education, that is, one which relies heavily on memorization and lecture, sometimes at the expense of "broad and deep understanding" of the subject matter—the fundamental principles of science. Frequently, the tendency to learn by memorization is exacerbated by the lack of practical, concrete laboratory activities that are relevant and motivating for students.

The conditions of university science education and the need for reform require close analysis of the purposes of a science education. There is a need to develop a science curriculum, teaching methods and programs of study that reflect the true nature of the scientific enterprise and the inter-relations among science, technology, and society. In short, there is a need for "authentic science" experiences in the basic science education of students.

### **The context for the study**

In order to establish the context for this study, it is helpful to consider several studies related to the notion of "authentic science." Duit and Treagust (1995) comment that "Science instruction, from the elementary school to the university level, is frequently disappointing as far as promoting students' understanding of science is concerned" (p. 46)

Previous studies have indicated that science education relies heavily on memorizing and regurgitating factual knowledge, with little concern for relevance to "everyday" practices. Frequently, students are reported to have memorized everything with little understanding (Feynman, 1985, p. 145).

Students study science, but they do not understand what science is. In addition, other studies (Carraher and Schliemann, 1982; Lave, 1988; Lave, Murtaugh, and de la Rocha, 1984; Schliemann and Acioly, 1989; Scribner, 1984) have pointed out that current problems of schooling are related to the distinction between practices at school and those of everyday life demonstrated by people while shopping, working in a dairy factory, tailoring clothes, or selling lottery tickets in street markets (cited in Roth, 1984, p. 198). Attempting to overcome these problems, some studies focus on issues related to creating a learning environment where students can learn and work with others in practical contexts. Roth (1994) summarized these issues about learning science from studies of Newman et al., (1984) and Rogoff (1990):

Key to the learning environments these critics propose as alternatives are contexts where students work with others on common, genuine tasks. These others preferably are more advanced adults and peers but could also be peers of equal or less advanced standing. By working together on problems, new knowledge is first constructed collaboratively in the joint problem space from which the learner subsequently appropriates it, that is, individually constructs his own representations. (cited in Roth, p. 199)

In addition, some studies have investigated the effectiveness of group work in negotiating meanings and forming consensus as an effective vehicle to help students learn science. Roth (1996) cited Wheatley's ideas about the effectiveness of group interactions:

From a constructivist perspective, collaboration among students holds great potential since group interactions provide an opportunity for the negotiation of meaning and arriving at consensus, important mechanisms in the equilibration of discrepancy and disagreement. (Wheatley, 1991; cited in Roth, p. 424)

In "non-traditional" laboratory settings, students worked together in groups of four to conduct their experiments. They were responsible for their learning in laboratory activities and were able to help each other by sharing and challenging practical experience or ideas, explaining concepts, and constructing new meanings on the spot. In more detail, Roth (1996) described student-student interactions:

We found that students negotiated meanings, the focus of an experiment, and activities, in different ways depending on the context. Primarily, students negotiated either in a collaborative mode, an adversarial mode, or by following the majority rule. When the members of a group shared a task, they could collaboratively construct the meaning of a concept. When the students could not come to understand each other's viewpoints, they challenged the expressed

ideas and demanded justification and backing, as adults do at professional conferences. Consensus was achieved through a majority rule when a group had to decide between equally strong proposals; the proposal selected was the one supported by the majority. (p. 440)

The “scientific method” used in the teaching laboratory is just one of many ways to think about the learning of science. But, this approach may be inappropriate for all purposes or objectives of physics laboratory courses. This method may not work in the case of everyday life practices because the authentic real-world phenomena very often appear as messy, complicated, and problematic. Hodson (1992, 1993b) states:

It is also the case, as argued above, that restricting the curriculum to learning science and learning about science will guarantee that most students are unable to do science for themselves. Though necessary, conceptual knowledge and knowledge about procedures that scientists can adopt, and may have adopted in particular circumstances in the past, are insufficient in themselves to enable a student to engage successfully in scientific inquiry. (cited in Hodson, 1996, p. 132)

Science education researchers have concern for creating learning environments in which students can actively learn by doing and by constructing their own knowledge and representations. In the investigator’s judgment, a teaching laboratory based on the “scientific method” is a poor vehicle to engage students in learning by doing. This has been largely a “technical rational” (Schön, 1983) approach in the past, as discussed in Chapter Three.

Certainly, understandings of the character of learning by doing are needed. The practical orientation of this study, therefore, is directed by a search for a model of learning with the promise to engage students in work with others to learn by doing science.

### **Significance of the study**

This study has helped the researcher understand the nature of learning science in collaborative laboratory activities. And, as documented in Chapter Two, there is very little research that deals with Schön’s ideas about reflective thinking in the area of high school and university learning in physics.

But, the significance of the study has yet another dimension. Participants in this study worked collaboratively with others on genuinely problematic experiments. They challenged expressed ideas to search for a genuine explanation, and they felt quite free to design their own experiments in their search for solutions. The model of reflective learning, based on Schön's conceptualization of reflection-in-action, interwoven with ideas about collaborative learning, provides a useful perspective and set of tools for improving students' understandings of concepts and procedures in science.

### **Data gathering and analysis**

This study is presented as a case study designed to explore learning events in a physics teaching laboratory. Data were gathered about two groups from a class of thirty-two second-year science students enrolled in a physics laboratory course at Cantho University. The study took place between the latter half of February and the end of April in 1996. The experiment designed for this study was the "Wheatstone Bridge" experiment (an electrical experiment).

Data sources included video tapes recorded of learning activities in the physics laboratory, interviews with eight students, and a survey of seventeen students. Students' discussion during laboratory work were copied to audio tapes which were transcribed and translated into English for analysis.

Data were analyzed by coding events in terms of Schön's conceptualization of reflection-in-action and by seeking patterns and insights about students' "authentic" science learning.

### **A preview of the study**

This document is presented in five chapters. Chapter One, the focus of the study, consisted of the problem statement and research questions, the justification of the study, and the practical orientation. Chapter 2 consists of a review of literature dealing with the matter of

university teaching and learning science and serves to “locate” the problem and to demonstrate the uniqueness of this research study. In Chapter 3, the elements of reflection-in-action that comprise the theoretical framework are explicated and set against a brief review of other notions concerning the nature of learning in science. Chapter 4 presents the research methodology used in this study and the findings from the data analysis, which demonstrate that the concept of reflection-in-action is applicable and appropriate for making sense of “authentic” science. Finally, the argument of the study is reviewed in Chapter Five and conclusions, limitations, and implications for further research and practice are discussed.



## Chapter 2

### Review of related literature

#### Position statements

A portion of the international science education literature deals with the recommended standards for learning science. During the past twenty-five years, several position statements have been advanced by prestigious organizations concerning the interaction of science, technology and society. In 1972 the United Nations Educational, Scientific and Cultural Organization (UNESCO) put forward the following position statement for Learning To Be:

An understanding of technology is vital in the modern world and must be part of everyone's basic education. Lack of understanding of technological methods makes one more and more dependent on others in daily life, narrows employment possibilities and increases the danger that the potentially harmful effects of the unrestrained application of technology--for example alienation of individuals or population--will finally become overwhelming. Most people benefit from technology passively, or submit to it, without understanding it. They cannot, therefore, control it. Education in technology at the conceptual level should enable everyone to understand the ways in which he can change his environment. (UNESCO, 1972, p. 66)

Sixteen years later, the International Network for Information in Science and Technology Education summarized recommendations put forward by Netherlands Science Shops as an orientation to develop innovations in the fields of interactive science and technology education, from which students are engaged in everyday life practice:

... all offer indications of what alternatives to the traditional 'top down' mode of bringing science into everyday life might look like. Similarly, recent innovations in the fields of interactive science and technology centers, such as those mentioned by Ingrid Granstam in her contribution on the science and technology education of girls (page 47), have the potential to make significant contributions. In all these examples, the emphasis is on science being adapted to people rather than people having to adapt to science. Interestingly, the experience of the Netherlands Science Shops was that, once embarked on this path, gaps in the existing body of scientific knowledge were exposed; science had not previously addressed some of the questions to which customers of the shops sought answers. (INISTE, 1988, p. 2!)

With a point of view similar to that of Unesco and INISTE, the Science Council of Canada (1984) recommended major initiatives that are urgently required for the Renewal of Science Education, focussing on the science-technology-society connection, the development of scientific literacy, and the teaching of real or "authentic" science. These recommendations are summarized as follows:

#### Redirecting Science Education

##### 4. Presenting a more authentic view of science (p. 11)

The view of science and technology presented to students should include historical, social and philosophical dimensions. (p. 37)

##### 5. Emphasizing the science-technology-society connection (p. 11)

Science should be taught at all levels of school with emphasis and focus on the relationships of science, technology, and society in order to increase the scientific literacy of all citizens. (p. 38)

### **The view of Technical Rationality on learning science**

Many science educators believe that the nature of science is at one and at the same time a body of knowledge and the process of acquiring and refining knowledge. The Science Manpower Project (1960) stated a definition emphasizing the dual nature of science:

Science is a cumulative and endless series of empirical observations which result in the formulation of concepts and theories, with both concepts and theories being subject to modification in the light of further empirical observation. (cited in Thurber and Collette, 1964, pp. 2-3)

In this definition, science is often taught as a body of established facts obtained by scientists using the scientific method. Scientific inquiry includes two branches of scientific reasoning, classed as inductive and deductive. In the teaching laboratory, components of the scientific method include basic scientific skills and integrated scientific skills. The former includes observing, inferring, measuring, predicting, classifying, collecting the data and recording the data. The integrated scientific skills are interpreting the data, formulating hypotheses, identifying and controlling variables, defining operationally. (Gagné, 1967; American Association for the Advancement of Science (AAAS), 1965). There is a hierarchy of

process skills in which the basic processes are regarded as essential for understanding and using the integrated processes.

In addition, technical rationalists assumed that problems of practice are well-formed and subject to rule-like generalizations. Thus, professional practice is characterized by the application of scientific knowledge across a variety of contexts, in which problems are well-defined with single correct solutions. Schön (1983) states:

According to the model of Technical Rationality -- the view of professional knowledge which has most powerfully shaped both our thinking about the professions and the institutional relations of research, education, and practice-- professional activity consists in instrumental problem solving by the application of scientific theory and technique. Although all occupations are concerned, on this view, with the instrumental adjustment of means to ends, only the professions practice rigorously technical problem solving based on specialized scientific knowledge. (p. 21)

The concept of "application," derived from technical rationality, leads to a view of scientific knowledge as a hierarchy in which facts and concepts occupy the highest level and technical problem solving, the lowest. In teaching and learning science this conceptualization casts students as subjects who faithfully memorize factual knowledge transferred by teachers or textbooks, a form of repetition. Consequently, learning science is based on the mastery-of-content and results in three phases of teaching procedure: inform, practice, and verify. Laboratories are exercises with a primary focus on the verification of established laws and principles or on the discovery of objectively knowable facts, a form of re-memorization and repetitive practice. As based on scientific method, students manipulate science process skills for testing the authenticity of what they have been told in lectures: the laboratory inquiry (Renner, 1984; Tobin, 1990).

According to the model of technical rationality, there are: separation of means from the ends, of research from practice, and knowing from doing. It rests on an objectivist view of the relationship between practitioners and the reality they perceive (Schön, 1983, p. 78). Within technical rationality, the familiar hierarchy is applied to the normative university curriculum in which practice is said to be guided by the principles of the applied sciences; the applied

sciences are guided in turn by the basic sciences. Practice is assigned the lowest value in the hierarchy, and the highest status is assigned to theory and to those who conduct theory-building research (Munby and Russel, 1989, p. 72).

### **Criticisms of the Technical Rationalist view of learning science**

The fundamental flaw of technical rationality comes from the assumption that science is a practice which depend almost entirely on deductive applications of known laws. This model fails to deal with practical competence in "divergent" situations (Schön, 1983, p. 49). A related criticism of the technical rationalist view comes from research spanning and interconnecting cognitive anthropology, cognitive science, and social psychology (Lave, 1988; Collins, Brown, and Newman, 1989; Newman, Griffin, and Cole, 1989; Rogoff, 1990; Roth and Roychoudhury, 1993a; cited in Roth, 1994, p. 198-199). The technical rationalist view holds that knowledge, which matches reality in one-to-one correspondence, can be transferred from lectures and textbooks to passive learners (Roth, 1994). From this perspective, learning is thought to occur through participation in actual work settings (Collins et al., 1989). Students therefore are not exposed to practices of everyday life demonstrated by people while shopping, working in a dairy factory, tailoring clothes (Carragher and Schliemann, 1982; Lave, 1988; Lave, Murtaugh, and de la Rocha, 1984; Schliemann and Acioly, 1989; Scribner, 1984; cited in Roth, 1994, p. 198). And, the learning environment is embedded in a context within which students rarely work with others on common, genuinely problematic tasks to construct their own representations and new knowledge (Newman et al., 1989; Rogoff, 1990). Neither do they work on projects in order to encounter the task of formulating their own problems, guided on the one hand by general goals they set and on the other hand by 'interesting' phenomena and difficulties they discover through their interaction with the environment (Collins et al., 1989). Students do not decide to make up their own

problems to seek out solutions when it is not clear what needs to be done in their search for genuine knowledge (Wheatley, 1991).

Students study science but they do not understand what science is. Other studies of science laboratories linked to a technical rationalist view concluded, rightly or wrongly, that current science teaching rests on an inappropriate epistemology. Collaborative methods are claimed not to be used in science laboratories. Some researchers claim that laboratory instruction has not been able to achieve the results for which it was designed, and it has fallen short of its intent to make better meaningful learning (Tamir, 1989; Tobin, 1990).

Other studies have shown that most students in laboratories gained little insight regarding either the key science concepts involved or the process of knowledge construction (Bogden, 1977; Buchweitz, 1981; Waterman, 1982; cited in Edmonson and Novak, 1993, p. 551).

Roth (1996) summarized the research (Gallgher and Tobin, 1987) which has provided some insights into the use of laboratory instruction in science. In these studies, students gathered data without understanding the meaning of their actions, got around their assignments in a leisurely atmosphere, and spent of their time off-task, socializing with their peers. The cognitive demand of laboratory tasks was reduced to a minimal level and precluded reflective thought. These structured laboratories incorporated minimal scope for students to connect their personal experiences to establish scientific principles. It is, therefore, not surprising that traditional laboratories often fail to provide an appropriate learning environment (p. 424). Finally, the goal of science education is to help students acquire skills for future careers in field such as mathematics and basic sciences. Yet these skills as they are developed in schools differ from those needed in these fields (Brown, Collins, and Duguid, 1989; cited in Roth, 1994, p. 198).

Referring back to the technical rationalist view, students just practice well-formed problems derived from textbooks. This view limits students' ability to practice in other problem-solving contexts. Roth (1994) states that problem-solving contexts include cognitive,

cultural, social and physical aspects, portraying a view of cognition as "situated practices" (pp. 199-200).

### **Promoting authentic science**

The science laboratory has been regarded as the place where students should learn the process of doing science. Yet, science educators in the 1960s held that students could employ components of scientific method as a means for the scientific investigations in the manner of well-known scientists (Gagné, 1963). Hodson (1996) states that "in reality, doing science is a messy, unpredictable process that requires scientists to devise their own courses of action. In that sense, science has no one method, no set of rules or sequences of steps that can be applied in all situations. In addition, it should not be thought that science has no method. Science does have methods, but the precise nature of these methods depends on particular circumstances: the nature of problems, the phenomenon, the theoretical understanding of the inquirer, and so on" (p. 129-130).

The "scientific method," as it is frequently expressed, for example, in some high school science text books as being a linear process that leads to correct conclusions about the natural world is flawed (Thurber and Collette, 1967). Scientific reasoning is heavily affected by a cobweb of transscientific social relations in which scientists locate their laboratory reasoning and action (Knorr-Cetina, 1981a; Latour, 1987). Induction bears very little resemblance to scientific practice (Haré, 1983). Induction is limited to the generation of hypotheses from observation, but often times scientific understandings can not arise by empirical means alone. The weakness of deduction lies in the fact that completely logical but false conclusions can be derived from faulty generalizations (Thurber and Collette, 1967).

Like all other people, scientists are entrapped in a mesh of personal and social circumstances. They have their own biases, preferences, social values and psychological attitudes (Gould, 1989). Consequently, the scientific method is a myth because the procedure

that scientists conduct scientific investigations is not fixed (Hodson, 1996). In addition, the myth of the scientific method is established when the scientists strip the contextual factors and report their new constructions as if they were the product of unaltered intentions (Knorr-Cetina, 1981a; Latour, 1987). Finally, the myth of the scientist as an impartial, detached observer has been exploded (Gould, 1984)

Hodson (1996) argues that “the science process skills reveal some limitations in dealing with different contexts. Competence in a skill such as observation cannot be transferred from one context to another unless the two contexts, and the scientific concepts they embody, have much in common. Transferability depends on familiarity with the relevant concepts, and so a demonstrated capacity to perform a skill in a particular context is no guarantee of skill in a conceptually different context. And competence in classifying, predicting, and hypothesizing, for example, cannot be transferred to a context which is independent of the context in which that skill was acquired. In reality, the context in which skills are acquired is crucial to the proper performance of those skills and to students’ confidence with scientific inquiry” (p. 126). It usually takes many years for scientists to conduct scientific research. A technical rationalist view implies that students should learn by doing science through verification laboratories, that is, through “proving again” the laws of science by showing how they “fit the data.” “Learning by doing science like scientists” may therefore be nonsense and an inappropriate representation of the authentic view of science in a traditional physics laboratory.

The Ministry of Education (1991) in New Zealand states that “Science is an activity that can be carried out by people as part of their everyday life” (p. 8). It follows from this recommendation that the only effective way to learn by doing science is through problem-rich learning environments in which students learn to investigate phenomena of their own interest and in which they can develop complex problem-solving skills (Roth, 1994, p. 199).

Glaserfeld (1993) holds that there is no end point to the evolution of the explanatory models we construct. According to Glaserfeld, truth is based on coherence with our other

knowledge, not correspondence between knowledge and objective reality (1984; cited in Edmonson and Novak, 1993, p. 548). Viability of knowledge replaces the notion of "truth" (Glaserfeld, 1992; cited in Ritchie and Rigano, 1996, p. 779). And, Bodner (1986) noted that construction is a process in which knowledge is both built and tested (cited in Ritchie and Rigano, 1996, p. 779). In this view, students actively construct and reconstruct their understanding rather than receiving it from teachers or textbooks. As a consequence, Tobin (1990b) advocates that students must be given:

... opportunities to experience what they are to learn in a direct way and the time to think and make sense of what they are learning. Laboratory work appeals as a way of allowing students to learn with understanding and, at the same time, engage in the process of constructing knowledge by doing science. (cited in Roth, 1994, p. 198)

But, the crux of the matter is the question of which model of learning is most appropriate and applicable in helping students to learn and to work with peers on common, genuinely problematic tasks, make up their own problems, and to construct new knowledge. The purpose of this study is to search for a model of learning that helps us understand how students learn by doing science.

## **Physics knowledge**

This study investigates students' learning of physics concepts in the physics laboratory. Some preliminary comments about the nature of the subject matter students are learning will be useful—subject matter related to the study of electricity.

Physics knowledge may be viewed as consisting of three aspects: *mathematical*, *declarative*, and *practical*. Physics borrows from mathematical fields to build knowledge of its own. For example: the Fourier transform, the Laplace transform, differential equations, and so on. Both mathematical and declarative knowledge are transmitted to students by lectures and textbooks. In teaching and learning physics, concepts of various degrees of complexity, abstractness, and importance are used, including empirical and theoretical ideas. Less abstract



ideas include descriptions of resistors, wires and light bulbs, while theoretical concepts include such things as electrons, current, voltage, power, voltage input, voltage difference, and so on. These concepts cement together to make up the conceptual systems that represent our knowledge of the world and universe. Examples of descriptive conceptual systems are: circuit diagram, games such as chess, football and so on. Theoretical conceptual systems are exemplified by electron theory, electro-magnetic theory, Ohm's law, atomic-molecular theory, and so on.

Another aspect of physics teaching and learning is the extent to which learning is based in experiences that are relevant and practical to the "every day" world and activities of students. The manner in which scientific models and theories are introduced to students is of vital importance. If there is little connection between theoretical concepts and physical phenomena students interact with, one might become suspicious about the extent to which a "deep" understanding of science is developed. If concepts and principles are merely memorized, with little or no regard for their use in explanation, one might raise important questions about the value of schooling in science.

### **Studies about problem-solving approach in authentic context**

By conducting a computer search on a data base system, I found that there are very few studies relating to physics students' performances using a problem-solving approach to promote authentic science. One quantitative and qualitative study conducted by Vietnamese scholar -- Le Van Hao -- explored an approach to teaching introductory physics which drew on the history of science and the use of demonstrations. Four other studies investigated physics students' performance in a problem-solving context, interactions in an open-inquiry physics laboratory, and laboratory apprenticeship through a student research project.

Roth and Roychoudhury (1993) examined the development of integrated process skills of physics students in authentic real-world contexts:

The findings from the study indicate that students develop higher-order process skills through nontraditional laboratory experiences that provided the students with freedom to perform experiments of personal relevance in authentic contexts. Students learned to (a) identify and define pertinent variables, (b) interpret, transform, and analyze data, (c) plan and design an experiment, and (d) formulate hypotheses. Findings of this study suggest that process skills need not be taught separately. Integrated process skills develop gradually and reach a high level of sophistication when experiments are performed in meaningful context. (p. 127)

Although I respect Roth's findings that process skills need not be taught separately, and that framing research questions plays a key role in an open-inquiry teaching laboratory, this study questions whether scientific skills, such as "identifying variables," or "hypothesizing," have much meaning in the absence of due consideration of the context of inquiry, or the particular problem which drives the scientific investigation.

Two recent studies have examined how science students thought and interacted in open-inquiry laboratories (Roychoudhury and Roth, 1996; Ritchie and Rigano, 1996). The former is a naturalistic study of student-student and student-teacher interactions, and of students' views of the effectiveness of group work in an open-inquiry physics laboratory. The latter is interpretive research conducted by Ritchie and Rigano concerning the viability of cognitive apprenticeships for learning science in school. They examined how high school students worked in a university chemical engineering laboratory under the mentorship of a university-based scientist:

We found that the students were empowered to seek empirically knowledge claims as they became independent researchers. (p. 799)

This research concluded that the context for the study varied from those contexts described in Roth's (e.g., 1994) studies in high school laboratories. In these classrooms, Roth's students were afforded autonomy and exercised a commitment to their project from the start. They argue that caution needs to be exercised before advocating open-inquiry as a general model for laboratory learning without additional studies in different contexts (p. 813).

In an effort to realize the potential of the laboratory to facilitate the learning of science concepts and skills, Roth (1994) studied high school physics students' experimentation and

problem-solving in an open-inquiry laboratory. He investigated whether these students used reasoning modes similar to those that appear during everyday practices of scientists and nonscientists alike. The findings of this study are summarized as follows:

This article shows the students' remarkable ability and willingness to generate research questions and to design and develop apparatus for data collection. In their effort to frame research questions, students often used narrative explanations to explore and think about the phenomenon to be studied. In some cases, blind alleys, students framed research questions and planned experiments that did not lead to the expected results. We observe a remarkable flexibility to deal with problems that arose during the implementation of their plans in the context of the inquiry. These problems, as well as their solutions and the necessary decision-making processes, were characterized by their situated nature. Finally, students pursued meaningful learning during the interpretation of data and graphs to arrive at reasonable answers to their research questions. We conclude that students should be provided with problem-rich learning environments in which they learn to investigate phenomenon of their own interest and in which they can develop complex problem-solving skills. (p. 197)

Roth's study provided evidence that physics students could solve complex problems related to their own interests and expertise. Schön's analysis of reflection-in-action was used by Roth to make sense of learning in a physics laboratory. However, this approach at the university level has not yet been examined, at least in the extant literature.

## Summary

The relevant literature reviewed in this chapter helps to "locate" the problem and to identify the uniqueness of this study. Some previous studies of "authentic science" have been reviewed. But, although position statements advanced from Unesco and Canadian councils are consistent with the purpose of this study, little if any work has focused on Schön's analysis of reflective thinking to make sense of learning in the university laboratory setting.

In Chapter Three the conceptual orientation of this study is put forward by establishing a view of learning by doing science that focuses on problem-solving. This will provide the background for the elaboration of Schön's notion of reflection-in-action as a vehicle for promoting "authentic" science.

## Chapter 3

### Theoretical framework

Schön's work arose in a context of strong opposition to technical rationalist approaches to education in professional schools. To Schön (1983), technical rationality implies a separation of means from ends, of research from practice, and of knowledge from doing. It rests on an objectivist, mechanistic view of the relation between knowing and doing. In contrast to the technical rationalist view, the tenets of reflection-in-action provided by Schön assert that practice *is* a kind of research, that means and ends are framed interdependently, and that, in the inquiry process, there is a transaction with the situation in which knowing and doing are inseparable.

### Reflection-in-action

Donald Schön's *The Reflective Practitioner* (1983) and *Educating the Reflective Practitioner* (1987) present a conception of "knowledge-in-action" which contributes to our understanding of learning practices. In setting out an account of learning through reflection in and on practice and of the professional knowledge inherent in practice, Schön (1987) begins by challenging the opposing school of thought that he sees as the "dominant epistemology of practice:"

Technical rationality is an epistemology of practice derived from positivist philosophy, built into the very foundations of the modern research university (Shil, 1978). Technical rationality holds that practitioners are instrumental problem solvers who select technical means best suited to particular purposes. Rigorous professional practitioners solve well-formed instrumental problems by applying theory and technique derived from systematic preferably scientific knowledge. (p. 4)

Schön (1983) opposes the notion that a science-like body of knowledge—on its own—is able to direct professional practice in any straight-forward way:

Among philosophers of science no one wants any longer to be called a Positivist, and there is a rebirth of interest in the ancient topics of craft, artistry, and myth—topics whose fate Positivism once claimed to have sealed.

It seems clear, however, that the dilemma which afflicts the professions hinges not on science per se but on the Positivist view of science. From this perspective, we tend to see science, after the fact, as a body of established propositions derived from research. When we recognized their limited utility in practice, we experience the dilemma of rigor or relevance. But we may also consider science before the fact as a process in which scientists grapple with uncertainties and arts of practice. (p. 48-49)

In reconsidering the nature of everyday life knowledge applied for professional practice, Schön honors the competence of professionals, who face difficult and complex problems in their practice, and he seeks a view of learning by doing based on reflective inquiry. I believe this view of learning by doing has great potential for the promotion of "authentic" science in the teaching laboratory:

When we go about the spontaneous, intuitive performance of the actions of everyday life, we show ourselves to be knowledgeable in a special way. Often we cannot say what it is that we know. When we try to describe it we find ourselves at a loss, or we produce descriptions that are obviously inappropriate. Our knowing is ordinarily tacit, implicit in our patterns of action and in our feel for the stuff with which we are dealing. It seems right to say that our knowing is *in our action*. (p. 49)

Schön prefers the process of decision making to the decisions themselves. He defines "reflection-in-action" as a means to put real-world knowledge into play, in terms of both "problem-setting" and "problem-solving:"

When we set the problem, we select what we will treat as the "things" of the situation, we set the boundaries of our attention to it, and we impose upon it a coherence which allows us to say what is wrong and in what directions the situation needs to be changed. Problem setting is a process in which, interactively, we *name* the things to which we will attend and *frame* the context in which we will attend to them. (p. 40)

When students face phenomena which appear surprising or problematic, they draw upon their "frames" and their repertoire of exemplars. While going about their work, they engage in a "reflective conversation" with the situation. Students' past experiences are brought to bear on the situation; frames are imposed and bring to attention certain aspects of phenomena; a problem is set and actions that entail certain solutions are formulated. What students "see" in the situation hinges essentially upon their conceptual make-up and the way their reflection advances to solve the problem.

Referring back to the process of "problem-setting," it is worth stating that this is one of the activities in which students engage through reflective conversation. As the conversation proceeds, reflective inquiry frequently entails framing the problem situation:

The situation is complex and uncertain, and there is a problem in finding the problem. Because each practitioner treats his case as unique, he can not deal with it by applying standard theories or techniques. He must construct an understanding of the situation as he finds it. And because he finds the situation problematic, he must reframe it. (p. 129)

Reflection-in-action leads to on-the-spot-experimentation in which students discover what consequences and implications can be made to follow from the reframed problem:

In order to see what can be made to follow from his reframing of the situation, each practitioner tries to adapt the situation to the frame. This he does through a web of moves, discovered consequences, implications, appreciations, and further moves. Within the larger web, individual moves yield phenomena to be understood, problems to be solved, or opportunities to be exploited. (p. 131)

In the most generic sense, to experiment is to act in the exploration of the newly observed phenomena as well as to affirm the intended moves. For Schön, there are three forms of experimentation: exploratory, move-testing, and hypothesis-testing:

The practitioner has an interest in transforming the situation from what it is to something he likes better. He also has an interest in understanding the situation, but it is in the service of his interest in change. When the practitioner reflects-in-action in a case he perceives as unique, paying attention to phenomena and surfacing his intuitive understanding of them, his experimenting is at once exploratory, move testing, and hypothesis testing. The three functions are fulfilled by the very same actions. And from this fact follows the distinctive character of experimenting in practice. (p. 147)

Through reframing the problem, students sometimes conduct an exploratory experiment to see what follows:

When action is undertaken only to see what follows, without accompanying predictions or expectations, I shall call it *exploratory experiment*. This is much of what an infant does when he explores the world around him, what an artist does when he juxtaposes colors to see what effect they make, and what a newcomer does when he wanders around a strange neighborhood. It is also what a scientist often does when he first encounters and probes a strange substance to see how it will respond. Exploratory experiment is essential to the sort of science that does not appear in the scientific journals, because it has been screened out of the scientists' accounts of experimental results (perhaps because it does not conform to the norms of controlled-experiment). Exploratory experiment is the probing, playful activity by which we get a feel

for things. It succeeds when it leads to the discovery of something there. (p. 145)

To produce an intended change, students conduct a move-testing experiment:

Any deliberate action undertaken with an end in mind is, in this sense, an experiment. In the simplest case, where there are no unintended outcomes and one either gets the intended consequences or does not, I shall say that the move is *affirmed* when it produces what is intended for it and is negated when it does not. In more complicated cases, however, moves produce effects beyond those intended. One can get very good things without intending them, and very bad things may accompany the achievement of intended results. (p. 146)

A hypothesis-testing experiment is similar to the classical scientific experimentation in which the inquiry leads to an experiment to determine which hypothesis is the best suited to the problematic situation. Like Popper, Schön suggests the experimental hypothesis-testing follows a process of falsification:

The experimenter tries to produce conditions that disconfirm each of the competing hypotheses by showing that the conditions that would follow from each hypothesis are not the observed ones. As Karl Popper has put it, the experimenter conducts a competition among hypotheses, rather like a horse race. The hypothesis that most successfully resists refutation is the one that he accepts. (p. 143)

On-the-spot experimentation may lead to "experience versus expectation" for further reflection-in-action and experimentation within the situation. Such experience plays a crucial role in meaningful learning:

When intuitive, spontaneous performance yields nothing more than the results expected for it, then we tend not to think about it. But when intuitive performance leads to surprises, pleasing and promising or unwanted, we may respond by reflecting-in-action. Like the baseball pitcher, we may reflect on our "winning habits"; or like the jazz musician, on our sense of the music we have been making; or like the designer, on the misfit we have unintentionally created. In such processes, reflection tends to focus interactively on the outcomes of action, the action itself, and the intuitive knowing implicit in the action. (p. 56)

Reflection involves an interchange between students and the situation in shaping their experience and constructing new understanding, through attending to what Schön calls "back talk:"

But the practitioner's moves also produce unintended changes which give the situation new meanings. The situation talks back, the practitioner listens, and as he appreciates what he hears, he reframes the situation once again. (p. 131)

In keeping with the notion of "back talk," Schön speaks of the reflective "conversation" as being cyclic in character:

In this reflective conversation, the practitioner's effort to solve the reframed problem yield new discoveries which call for new reflection-in-action. The process spirals through stages of appreciation, action, and re-appreciation. The unique and uncertain situation comes to be understood through the attempt to change it, and changed through the attempt to understand it. (p. 132)

Schön contends that learning by doing hinges upon the integration of experience with reflection and of theory with practice. Experience is basic for learning but reflection-in-action is the essential part of the learning process as it results in both interpreting and extracting meaning from the experience.

When a beginning physics student sees a pendulum problem as a familiar inclined plane problem, he can set up the new problem and solve it, using procedures both similar to and different from those he has used before. Just as he sees the new problem as a variation on the old one, so his new problem-solving behavior is a variation on the old. Just as he is unable at first to articulate the relevant similarities and differences of the problems, so he is unable at first to articulate the similarities and differences of his problem-solving procedures. (p. 139)

This section has presented the set of constructs in the concept of reflection-in-action. Schön's epistemology of practice lies on the constructionist view of knowledge, in which students construct reality on the basis of the interaction between frames, appreciative systems, past experience, and the ways in which problems of practice are "seen," that is, the ways in which they are framed and reframed through reflecting-in-action on learning by doing science.

## Summary

This chapter presented Schön's model of reflection-in-action as a way of conceptualizing students' engagement in laboratory experiences designed to promote "authentic" science.

The notion of reflection-in-action is a promising view of learning by doing because it focuses on how students "see" phenomena, how they frame and reframe problems in science, and how they experiment in coming to solutions. Here, learning processes are conceived of in



terms of reflection-in-action—the means through which experience, theory and practice influence learning in physics labs. In summary, the model of reflection-in-action consists in four elements: problem setting, framing, experimentation and the “talk back.” The first two emphasize the epistemological characteristics of practitioners’ view of their practice. What students “see” in the events of practice is recognized as having influence on how they respond in situations.

Next, in Chapter Four, the elements of reflection-in-action derived from Schön’s writings are used to analyze the activity taking place in a physics teaching laboratory and to demonstrate the usefulness of this perspective.

## **Chapter 4**

### **Analysis of the data**

As outlined in Chapter One, the research problem of this study is to develop an account of a teaching innovation using a problem-solving approach to promote “authentic” science in a basic physics teaching laboratory in Vietnam. The analysis is focused on the following research questions: (1) How do students learn and apply science concepts to solve problems while doing their experiments? (2) What is the effect of this “authentic” science approach on students’ thoughts after the lab course about learning and science?

Chapter One included a brief discussion of the practical orientation taken in this study. A qualitative case study was developed by using video-tape recordings of students’ group work in the laboratory. This method seemed is best suited for an examination of learning events occurring in the physics teaching laboratory. In order to obtain information about students’ thoughts after the lab course, an interview and a survey were used. The purpose of this chapter is to present the research methodology and the findings of the study.

### **Methodology**

In 1994, Cantho University introduced a University Credit System and the first two phases of a basic science program (the first two years of university study). This program applies to study in subject areas such as Physics, Mathematics, Chemistry, and Biology—basic sciences. Students study mechanics, thermodynamics, and physics lab A for the first two semesters of their program. The remainder of the physics curriculum for the final two semesters includes optics, electricity, modern physics, and a physics lab. In other words, all science students learn science in lecture courses. After finishing these lecture courses, students enroll in the “lab A course” or the “lab B course,” according to the school year they enter.

As this study focuses on investigating students' learning in the physics laboratory at Cantho University, it was necessary to send letters to the Rector and Vice Rector of Cantho University requesting permission to conduct the research. It was also necessary to solicit the support of the Dean of the Faculty of Education to assign the researcher to teach the lab course (see Appendix I). The Dean of the Faculty of Education assigned the researcher to conduct the study in a class of thirty-two second year physics teacher education students from March 01, 1996 to April 25, 1996.

In order to develop deep understanding about educational events related to learning by doing science, this case study followed one group of four students in an investigation related to their study of electricity. Each student who participated in this study was asked to sign a consent form outlining the assurance of anonymity and confidentiality, as well as an explanation of how the information was collected from interviews (Appendix I).

A qualitative case study is best suited to this examination of learning since I am interested in the quality of learning events as well as the representation of students' activity and discussion in the physics laboratory. The case study is based on conversations and observations of the activities of participants and processes investigated. Video-tape-recordings of lab activities and interviews with students were used in collecting data for this analysis. The analysis involved transcribing group conversations and observations of the lab activities, interviews with eight students (see Appendix II for the interview protocol), and a survey of seventeen students taking the lab course (also presented in Appendix II). The analysis of these transcripts involved sorting and characterizing statements according to the theoretical framework derived from Schön's notions of reflection-in-action and the review pertinent literature in science education research. Categories of events were coded and checked both for their consistency with Schön's framework, and their capacity to "capture" the quality of learning events taking place in the laboratory activities. Interviews, together with the student survey, were analysed to shed light on students' renderings and understandings of their

learning experiences in science (a complete interview and the survey results are presented for the interested reader in Appendix III).

### **Data collection**

In order to take into account students' actions and understandings in practice, some preparation was required. First, it was felt that by including difficult problems in the laboratory activities investigated, students would have to deal with the problematic, messy, and complicated situations in practice. As the laboratory instructor, the researcher paid attention to whether students were comfortable with the research. Once the situation was stable, the researcher began preparing for the major steps in taking video-tape-recordings. It is worth pointing out that there were some conveniences in preparing these steps. Some international officers from Japan and Holland visited Cantho University and taped students' activities while they were practicing in physics lab A. Students therefore had some experience in dealing with a situation similar to the one in this study. Second, it was fortunate that the video-tape technicians were also electronic technicians, with technical insights involving electricity. This fact contributed to observations and conversations for data analysis in this study, since the technicians had a good sense of important events to capture on video tape. For example, the technicians recorded not only all of the pertinent electrical phenomena taking place throughout the lab activities, but knew when to focus on students' discussion and problem-solving strategies evident in their calculations on paper. Thus, the video tapes contained a complete record of learning events, enabling a thorough analysis by the researcher.

The first section of the analysis presented below pertains to a "Wheatstone Bridge" experiment that was conducted by a group of four students in the laboratory. A complete transcription of this sequence of activities is presented in Appendix IV, together with analytical

comments showing how Schön's categories were used to make sense of the learning events.

Thus, the focus of this first section is "learning in practice."

The following is the procedure for the "Wheatstone Bridge" experiment:

- a. With a given resistor students vary the voltage of a source having a range from 4.5V to 7.5V and use an ampere-meter to measure the values of the current conducting through the resistor. They then collect the data and verify Ohm's Law.
- b. By way of an electrical circuit including two unknown (different) bulbs in parallel and a 3 VDC power supply, students are asked to analyze and to explain the phenomenon derived from this experiment (the bulbs light with different brightness).
- c. Students conduct similar steps as in experiment (b) but with same two bulbs attached to 6 VDC source.
- d. Students experiment with two different series circuits in parallel with an output voltage of 6VDC. Each circuit has an resistor connected in series with a light bulb. Two light bulbs are the same but the resistors are different. After observing the brightness of each bulb students reason and conclude the difference between two resistors.
- e. Students use the 'Wheatstone bridge' apparatus to measure the values of above resistors. Then they compare with the values of two resistors to test their conclusions.

Video technicians were also given a plan for the experiments in order to have some preparation for the taping activities. For example, they were told about the significance of the relative brightness of the two bulbs, the different values of current on the scale, and so on. In addition, two preceding experiments were videotaped as a pilot project to gain some experience before taping the "Wheatstone bridge" experiment.

In order to obtain feedback from participants in this study, an interview was conducted in April, 1996. This interview was guided by "standardized open-ended questions" (see Appendix II). The students were asked the same questions in the same order. The interview questions were designed to obtain information about the effect of this teaching approach on students' thoughts toward learning science and about science, and their reflections on their experience using science concepts to explain natural phenomena.

Along with the interview, a survey (see Appendix II) was used to obtain more information about students' thoughts toward science and about learning after the lab course.

## Data analysis

The data analysis was analyzed in the following ways: First, the students' dialogue was coded and categorized to fit into the categories of the theoretical framework derived from Schön's work and the literature review. The discussion was coded in a broad way initially, and then further broken into subsequent levels to identify finer categories. These categories were then charted in order from the beginning to the end of the analyzed transcripts. Thus, the analysis was focused on identifying "acts of reflection" detected in the events of learning recorded in the teaching laboratory.

In this study, Schön's notion has been applied to the context of learning through authentic science in the physics laboratory. Schön developed six categories in his conceptualization: problem-setting, reframing, exploratory experiment, move-testing experiment, hypothesis-testing experiment, and "talk back."

Problem-setting is the process by which students identify the problematic phenomena of the situation in action. Reframing is "seeing" in the situation new particulars that give rise to a new understanding of the problematic phenomenon, as well as to new possibilities for action in the situation. Practically speaking, the latter categories are necessary to offer opportunities for students to learn in practice those insights derived from the former categories. Experimentation is undertaken to explore the newly observed phenomena as well as to affirm the intended moves.

The analytical scheme is presented in terms of Schön's ideas about reflection-in-action, together with additional categories added as a result of the analysis, such as "surprising events," "experience," "scientific skills," "scientific reasoning," and so on. For example, the researcher used categories of "scientific reasoning," and "scientific skills" to track for limitations of the "scientific method" applied in practice.

Acts of reflection occur in three phases, which may be collectively referred to as "cycle of reflection in learning." The reflective learning cycle consists of three phases: problem-

setting, reframing, and the resolve (MacKinnon, 1985). The notion of the learning cycle is used to describe the students' dialogue and activities in the physics laboratory in a way that highlights the reframing of the problem that occurred, as well as the new implications for experimentation that resulted from their learning.

### Phase I: Initial problem-setting

Phase I includes the initial "setting" of the problem. Students begin this phase by posing questions, criticizing, and calling to attention related concepts, reasoning skills, and experience, which help to define the problem. The setting of the problem allows students to formulate an initial conclusion about the problematic phenomenon for later moves. This sets the discussion up for the second phase of the reflective learning cycle.

### Phase II: Reframing

In this phase, the problematic phenomenon is re-examined from one or several platforms. Reframing does not necessarily occur only once; it may occur several times. Students conduct experiments, including hypothesis-testing experiments, move-testing experiments, and exploratory experiments. Often moves may lead to further "acts of reflection." On-the-spot experimentation may work to yield intended results, or it may produce surprising events that call for further reflection and experimentation, which often lead to subsequent reflection and the reframing of the problem. During this phase, teachers not only observe and listen carefully to students' discussion and activities, but also call attention to students' surprises on-the-spot to help them shape their understandings about the phenomenon. The result of the reframing process is a deeper understanding of the problematic phenomenon, a search for insights derived from prior knowledge and experience in an effort to achieve a productive view of problem and its solution.

### Phase III: Resolve

The resolve is the 'talk back' of the product of all of the work done in phase II. A new conclusion about the problematic phenomenon and a new implication are sometimes derived.

## **Analysis**

### The reflective learning cycle

According to the laboratory design (step 1), students begin with an experiment to establish Ohm's law, verifying the authenticity of what they have learned in the lecture. Students then conduct new experiments involving everyday life practice, as ways to explore how they apply Ohm's law.

Two excerpts of discussion with the four participants—pedagogical physics sophomores—who undertook physics lab B conducted by the researcher will be presented here. The first excerpt begins with their discussion and activities in preparing for the first part of the experiment to establish Ohm's law. To, the head of the class, tells members of the group to check the electrical equipment and to set up the first circuit according to the lab instruction:

To: Before practising, let's check the electrical ... instruments of this experiment. A power supply. A galvanometer. An electrical wire strained on two terminals of a stick-meter. A ... contact switch K, a resistor box R. Some unknown resistors. Two 3 VDC bulbs. Two bulbs of unknown rated voltage. One VOM and digital multi-meter. This is a resistor box, right? Now, let's set up the circuit on the figure 1. Ti, set up the circuit please

Ti, the head of the group, and Th and Ng share their work by checking the electrical equipment, and setting up the circuit:

Ti: Where is the ampere-meter? ... Connect to its terminals, please. The ampere-meter. Let's connect



two terminals to ... the amperè-meter. And the power supply ...

- Ng: The power supply ... All right! But the power ...
- To: One terminal of the ampere-meter is connected in series with the resistor R
- Ti: This resistor? Is this a resistor?
- Th: Yeah, that's right
- Ti: How about that terminal?

After setting up the experiment, the students request the researcher to check whether the experimental set-up is correct or not. The researcher examines their circuit and tells the group some cautions in setting the scale switch before measuring the current flowing through the resistor:

- Ti: Let's check the circuit to see whether it is correct or not. Should we ask the teacher?
- Ng: I think this is a simple circuit. We will do it all at once. OK! Already!
- To: Teacher, please check our circuit, sir
- Ti: Check this circuit, please. I think we set it up correctly. Is this a resistor, sir?
- Teacher: Yeah, it is. Please pay attention that you should set this upon to its current scale. If the current which flows through it is small, you change it into milli-ampere scale. And, if the current through it is high, for example, 20 amperes, you should change it to the ampere scale here
- Ti: 20 amperes! OK! Turn on the power supply, please

After conducting the first experiment, the participants begin the second experiment. The second excerpt is their discussion and activities in preparing and conducting the initial step of this experiment. First, Ti tells the members of the group to read the lab instruction about the second circuit, while the others set up the experiment. Ti then decides to continue the lab activity by setting up circuit A:

- Ti: Now, follow the lab instruction to do the second circuit, right? Read the instruction for the second circuit, please
- Th: Set up three circuits of the figure ... A ...
- Ti: First, let's do the circuit A ...
- Th: In A's, the current flows through two different bulbs
- They begin to conduct the experiment:
- Ti: Where are the two bulbs? There are two different bulbs, already? Turn on the power supply to measure, please ... How many?
- Th: Now, the output voltage of the power supply is 3 V, right?
- Ti: 3 V, really?
- Th: 3 V
- Ti: 3 V, right? Adjust to 3V, OK? Twist it. Twist tightly ... Do not be afraid
- Th: Vary to increase the output voltage a little more. It's up
- Ti: Already!
- Th: ... It's correct

After conducting the first step of the experiment, the participants begin dealing with the problem arising from this activity. In accounting for the phenomena, participants complete a reflective learning cycle with the idea that the dim bulb is less bright because its rated power is higher, and the bright bulb has a lower rated power. Unlike learning in a more traditional laboratory, participants in this study actively learn by doing science. They work with others to examine genuinely problematic phenomena related to the practical work of the laboratory. Members of the group share their work and ideas to construct a new meaning of the concept of rated power, and help each other to shape and develop practical knowledge about proceeding with this experiment. When they experience difficulty in communicating, they challenge the expressed ideas to search for an appropriate explanation. They construct their own

representations, and “set the problem” on the basis of their prior knowledge and experience. They frame reflective questions and design experiments needed for their inquiry. In addition, on-the-spot experimentation leads students to further surprising events, such as their discovery that the current flowing through the dim bulb is higher than that of bright one. Such surprises help students test their representation of the problem and its solution by designing move-testing experiments. Finally, they bring familiar concepts to re-examine the problematic phenomena, and construct new implications and conclusions for further experimentation.

The following excerpt of participants’ dialogue and activities will be presented in order to display for the reader how these physics students learned and applied science concepts to solve problems related to the “Wheastone Bridge” experiment.

### Phase I: Problem Setting

After setting up the experiment, Ti describes the phenomenon that has become the evidence in this activity: *Already? Now, the output voltage of the power supply is 3 V. It is unchanged. Now, how do we consider about these two bulbs?* Additionally, in seeking understanding of the phenomenon, Ti frames a series of questions. First, he asks his friends to explain the different brightness of the two bulbs:

Ti: We observe that their brightness is different, right?

Th: It means that we have to ...

Ti: Why are they different?

Th implies that the difference in power (brightness) is due to a difference in current: *Because there are different currents flowing through them, the currents flowing through them are ... Two bulbs are different ...* However, it is not clear enough to account for the phenomenon. Ti frames a follow-up question involving the different intensities of currents flowing through two bulbs: *Do you know which one is higher and which one is lower?* Th recalls his everyday life concepts to relate “bright” as “high,” and “dim” with “low” for the explanation about the phenomenon: *To me, the bulb is bright because the current splits to it*

*more than ... that of the dim one. The current is higher. As though the concept of current is insufficient to explain the phenomenon, To explores other electrical characteristics: Now, it is not sure either to explain it based on the current ... We base on their bright level and dim level, basing on their electrical characteristics to explain why they are bright or dim?*

It seems that To's opinion leads to a controversy about the phenomenon. Agreeing with Th, Ti frames a question to explore the different intensities of currents flowing through two bulbs: *Now, Th's suspicion is that the currents flowing through the two bulbs are different. Now, how do we feel about which one has the high current?* With a doubtful attitude, To challenges the ideas expressed by Th and Ti by repeating Ti's question: *Which one has the higher current?* But, Th still confirms his response: *To me, the bright one is higher.* Ti concisely expresses a pre-conclusion about the phenomenon. Additionally, he confirms this conclusion by inviting other members of the group to contribute more opinions about the phenomenon. He poses the following question: *All right, our comment is that:  $I_b > I_d$ . How about Ng?* Ng, in a neutral manner, refutes the influence of the output voltage offered by the power supply on the parallel circuit. Additionally, he not only agrees with Th and Ti's opinion, but also follows To to suggest an account for phenomenon in terms of power and resistance: *To me, the bright level of the bulb is not affected by the output voltage. It is affected by the intensity of the current. But, in one hand, it is not enough ... It involves its resistance and power.* Here, it is seen that Ti slightly confuses Ng's opinion about the rated power: *The power, its rated power, right?* Ng repeats his opinion in terms of the power and the resistance by pointing out the relationship between the power supply and the load of the two bulbs:

Ng: In this case, I do not mention the voltage difference because the voltage that the power supply offers to it is 3 V. So its ... power also affects the bright and dim level

Ti: The power ... its rated power, right?

Ng: ... and its resistance ...

Ti turns to ask To about the phenomenon: *And, To, what do you think about that?* In a firm response, To expresses his disapproval: *Now, Th's opinion is to base on the brightness and the dimness of the bulbs. That means based on the intensity of the current.* Due to To's stable attitude, Ti gets in confusion as recognized by his voice: *... just judge so, just judge so ...* As if that were not enough, To continues pursuing this line of questioning by posing a question of "how:" *But how do we base on the intensity of the current to explain it?*

Ti brings his prior knowledge related to Thermodynamics and Ohm's law to explain the phenomenon:

Ti: OK! I think that at first, the bulb is bright because its filament burns up, right? The more it burns, the brighter it is, and the more luminous it is as well. We see, if the current which is flowing through it is higher, it is brighter. Because the current flows through it a lot, it creates more heat friction. Therefore, it is more luminous. So, I agree with Th's opinion

As well, Ng follows Ti's explanation: *It also emits heat, all right!*

Finally, it is worth pausing to analyze the statement "*It is just the judgment only, it means that we want ... want to test whether our judgment is wrong or right, ...*" Although this is a short passage, it contains a meaningful statement. With a confused voice, Ti figures out a conclusion about the phenomenon: "*It is just the judgment only ..., wrong or right.*" In this sense, this surprising event led to further experimentation. Students now move into the second phase of the reflective learning cycle, the first reframing activity, by setting out a hypothesis-testing experiment to account for the phenomenon.

### Reframing the problem

In this occurrence, Ti brings the practical knowledge to bear on the problematic situation. He suggests that the paralleled circuit can be split into two single ones to test them in a way similar to what they have done for Ohm's law. To the students, resistance, power cannot be measured. In tacit reference, among these terms, they must select which one can be

tested by their experiment. This activity gives ways to a series of hypotheses. It is not accurate to measure the resistance of the two bulbs because their values vary according to the voltage difference. The power cannot be measured directly with the electrical equipment available. Thus, the students only have one choice: to measure the current. The statement "*which one is higher than that one,*" leads to two possibilities: the current flowing through the bright bulb must be either higher or lower than the dim one. The students conduct an experiment to select which hypothesis is best. The following excerpt is the students' discussion of the current flowing through two bulbs:

- Ti: Because two bulbs are in parallel, just connect one. We use only one branch of the circuit ... Now, the input power supply connects to the milli-ampere meter, just 3V here. Take it to put here. Do you put it at the right position yet?
- Ti: Is it right? No, it is at the wrong position ...
- Ng: Over that position of reading scale, all right!
- Ti: OK!
- Ng: Here is exactly correct
- Ti: How many mAs are you observing on the reading scale? Is it correct? Exactly, it is 0.26 mA. OK! Turn it off. Where is the dim bulb? Where is the dim bulb? The Id ...
- Th: Turn on
- Ti: Turn it on ... It is ... 0.32

This test leads to a surprising event, with implication for further practice. Th and Ti realize that their understanding about the phenomenon is wrong. *As Th says: So we cannot conclude about the current. And Ti states: So, our conclusion is wrong. Recently, Th has said that  $I_b > I_d$ . Now, in the reality,  $I_d > I_b$ , right? Now, I think it involves to the resistance. How about the Ohm's law in this case?* Again, it is worthy pausing to comment about these passages .

The fact that students cannot directly apply their prior knowledge of Ohm's law or other principles to deal with problem, as Schön would say, the problem needs to be reframed. In addition, surprising events help Th and others shape their understanding and lead to further reflection-in-action to construct new understanding for the phenomena in terms of the resistance and the power. Students frame a first move to test the difference of the resistance of two bulbs:

Th:  $R = (U/I)$

Ti: We recognize that  $U/I = R$ , right? The output voltage which the power supply offers to them is the same, right? So  $U$  is ... Therefore,  $U = RI$ , or  $U_b = R_b I_b$ , and  $U_d = R_d I_d$ . But these two voltages are equal to each other because the output voltage of the power supply offered to them are the same. Hence,  $I_b = (U_b/R_b)$ ;  $I_d = (U_d/R_d)$ . And therefore,  $(I_b/I_d) = (R_d/R_b)$ . But we have concluded the above ratio already, all right!  $I_d > I_b$

Ng: Therefore, we have: that ratio is less than 1. It is less than 1

Ti: Hence, this ratio is less than 1, right? Its denominator is greater. So it is less than 1, right?

Ng: ... less than 1 ... Therefore,  $R_d < R_b$

Ti: Hence,  $R_d < R_b$ . The second conclusion is that  $I_d > I_b$

Ng: The resistance of the dim bulb,  $R_d$  ...

Ti: ...  $< R_b$

This reframing activity continues in a second move, which begins with the following question of Ti:

Ti: Now, is it related with the power? Its consumed power, the consumed power ...

Th: The consumed power of the bulb

Ti: ... right?

Th: Yeah ...

- Ti: Now, we have  $P = UI = (U^2/R)$ , right? So now,  $U_b^2 = P_b R_b$ , and  $U_d^2 = P_d R_d$ . Hence, these voltages are equal to each other, right? They are equal. Therefore, we have:  $P_b R_b = P_d R_d$ , right?
- Ng: Here is the paper. Here is the paper ...
- Ti: ... Now, we are establishing the ratio:  $(P_b/P_d) = (R_d/R_b)$ , right? And we have ... But this conclusion is  $R_d < R_b$ , the numerator is less than the denominator
- Th: ... The numerator is less than the denominator ...
- Ng: ... The numerator is less than the denominator. So its ratio is less than 1
- Ti: ... less than 1, right? Less than 1 ... less than 1. Because we have the ratio of  $(P_b/P_d)$  is less than 1. Therefore, we have:  $P_b < P_d$ . So, according to Ohm's law, we derive that the consumed power of the bright bulb is less than that of the dim bulb, that is  $P_b < P_d$ . Coming here already!
- Ng: This is the consumed power, right?
- Th: Yeah, the consumed power, exactly. We are considering the consumed power. It equals to  $(U^2/R)$

It is interesting to note that the students construct a new understanding of the phenomenon. Yet, this analysis is insufficient to answer the question, "*why one bulb is bright and the other is dim.*" For this reason, they move to the third reframing activity to achieve a deeper understanding about the phenomenon.

In the following activity, students focus on "discussing" but not "doing" to construct a new meaning for the concept of power, the *rated power*:

- Ti: OK! Each bulb looks like human being. It has a power. This power characterizes for a current flowing through it and the voltage difference on it. It means that it involves the power
- Th: The rated power. It is all right!
- Ti: ... The rated power
- Th: Yeah, it's right



Ti: What is the rated power? Is it the consumed power? When we increase the consumed power until the bulb glows at normal brightness, right? In this case, that power is called the rated power, OK? But each bulb

Ti first brings his experience to bear on the situation to make the analogy of human being having "power" to do something. Secondly, he calls attention to a the concept, "normal brightness," which, together with the notion of the consumed power, creates the meaning of rated power to account for the phenomenon. This leads students to look for another electrical concept that can account for the phenomenon:

Th: ... If the brightness of two bulbs involves the rated power, they have to involve to the rated voltage

Ti: The rated voltage as well

Th: Yeah, all right! According to this argument, how can we conclude which one has the higher rated voltage?

Ng: Not yet ...

Ti: ... but I question that, considering now ...

Ng: Yeah, if so ... because the output voltage of the power supply, recently, in each case is 3 V. We see that the bulb ... The bright bulb ... and ... the dim one were supplied with the same voltage. But seeing clearly that their brightness is different, right? So, it is clear to say that the rated voltage of the bright bulb is different from the dim one

Ti: What do you have to say about why they are different? How do you prove that their brightness depends on these two rated voltages?

Ng: If the rated voltage of the bright bulb is less than that of the dim bulb

Ng:  $U_b < U_d$

At this point, To suggests a move-testing experiment to infer the rated voltage from the brightness of the two bulbs by increasing the output voltage offered by the power supply:

To: Now, we found the difference between the two rated voltages already. It is all right. Now, in order to make sure that it is correct, we have to test them. By the mean ... Now, one bulb is bright, and other is

dim, right? This one is dim. Now, let's increase the voltage in order to make it brighter

- Ti: ... It means that we increase the voltage so that ...
- To: Yeah ... So that the bulb glows at normal brightness according to the rating of the manufacturer, that is the rated voltage
- Ti: OK! Now, let's split the circuit
- To: Increase at the same time. Increase their voltages so that the dim bulb will glow at a little bit more brightness, and the bright bulb will glow at little bit more than normal brightness

But, as Ng criticizes, To's method may limit the experiment because this circuit is in parallel. Therefore, To just gets one value of the rated voltage. On the other hand, it may damage one of the two bulbs to increase the applied voltage, if this increases above its rated voltage.

- Ng: To me, I think
- Th: All right!
- Ng: ... that it is not necessary to increase, because the voltage of each branch is the same, OK? In this case, they are offered by the same applied voltage. For example, if it is 3 V, each branch gets 3V. If 4 V, each branch gets 4 V
- To: Right, while increasing the output voltage of the power supply, the consumed powers of bulbs increase. But their brightness is different, right?
- Ng: Yeah, it is different. I agree with To's opinion that if we increase so that the bulb glows at normal brightness according to the rating of the manufacturer marked on the bulb. If not at that time ...

This argument leads students to conduct an exploratory experiment to see what follows. They offer two parallel bulbs with some output voltage, and observe the brightness of two bulbs as testing To's suggestion:

- Ti: Let's try in order to see what is going on?
- Ng: I worry a little bit that the small bulb will burn out

Ti: The voltage applied to the two bulbs increases at the same time, this one is brighter than that one

Ng: It is brighter, all right!

Students then proceed to reframe the way they had been thinking about the phenomenon. Due to the result from the exploratory experiment, Ti and Ng develop practical knowledge by suggesting splitting the parallel circuit into two single ones and increasing the applied voltage from the power supply from a low value to a high one to infer the rated voltage for each bulb:

Ti: Now, we separate them to experiment

Ng: OK! Why not?

Ti: Now, we separate them to test, OK?

Ng: It means that we measure the voltage difference between two terminals of each bulb, right?

Ti: Yeah! Yeah, right ... We vary the output voltage so that the bulb glows at normal brightness

Ng: It is enough. It means that we measure that makes the bulb glow at normal brightness. Ah ... uh, all right, OK ... OK, at normal brightness according to the rating required by the manufacturer

Ti: ... so that the bulb is white bright. It is all right!

Ng: ... in order to test how does the voltage change?

They then carry out two experiments and find out that the rated voltage of the dim bulb is 6 VDC, and that the rated voltage of the bright one is 3.5 VDC:

To: We vary the output voltage while reading

Ti: All right? Is it at normal brightness?

Th: Let it glow at a little more brightness ...

Ti: OK?

Th: OK! Nearly 6 V

To: Let's suppose that it is ... 6 V

Th: OK, 6 V

Ti: White already  
 Th: Nearly 3.5 V  
 Ti: Nearly how many volts?  
 Th: Nearly 3.5 V  
 Ti: 3.5 V

Here, students formulate a conclusion about the rated voltage of the two bulbs:

Ng: I think it is clear that ...  
 Ti: So the brightness is white, all right?  
 Ng: ... but their brightness is different. So it is clear that this bulb has low rated voltage  
 Ti: The rated voltage of bright bulb is lower  
 Ng: ... that of the bright bulb is lower  
 Ti: Nearly 3.5, right?  
 Th: Yeah  
 Ti: 3.5 V. Therefore, basing on the brightness, we see that their white brightness is the same like this. And the R? Where is the R noted on the paper? According to the power, that is the rated power, the power of the dim bulb. And it has to be the rated power of the dim bulb multiplied by the intensity of the current I  
 Ti: UI, UI, UI, right?  
 Ng: P, P equals to UI  
 Ti: The rated power of the bright bulb is equal to its rated voltage multiplied by its current intensity. But how many milli-amperes did we measure for the  $I_b$ ? And we have  $I_d > I_b$  ...  $I_d > I_b$ . But this power, the rated power, the rated power. We have I, we can conclude  $I_d > I_b$ . All right! We have a conclusion about the rated voltage. The rated voltage of the dim bulb is higher than that of the bright one

Thus, students come to the conclusion that the rated voltage of the dim bulb is higher than that of the bright one. Moreover, it is seen that the light bulb is influenced by two factors:

its rated voltage and its rated power. The students then begin to look for the difference between the two bulbs in term of the rated power.

The following excerpt illustrates students' dialogue for the different rated powers of two bulbs:

- Ti: So, which power is higher?
- Ng: The rated power, right?
- Ti: Yeah. Now, the rated power ... UI
- Ng: Yeah, the rated power of ... the dim bulb is higher than that of the bright one. And we can know how to find out those terms

Here, the need for an explanation leads the students to play out the last reframing activity. It is at this point, calling for attention that one student, Ng, raises a question that serves to connect the central reframing: *We have found that the rated power of the dim bulb is higher than that of the bright one. How come?*

Students construe the problematic phenomenon in two ways. First, they account for the phenomenon by involving the relationship between the rated powers of the two bulbs and the power supply:

- Ng: How about the power supply?
- Ti: The same
- Ng: The higher its rated power is, the dimmer it is
- Ti: Therefore, that is the power supply does not offer enough ...
- Ng: Yeah, so the bulb which has the high rated power has to be dimmer than the other one that has low rated power
- Ti: So, the power supply, the rated power of the dim bulb...
- Ng: The rated power
- Ti: The dim bulb. Now, let's discuss about the dim bulb, OK?

- Ng: Yeah
- Ti: The power, the power that the electrical source supplies to it is lower than its rated power
- Ng: Yeah, it is right ...
- Ti: How about the bright one?
- Ng: In short, nearly like that ... The power applied to it is nearly equal to its rated power. So, it glows at normal brightness. Nearly ...
- Ti: So, its brightness depends on the power
- Ng: Yeah

Secondly, the students specify the relationship between the output voltage produced by the power supply and the rated voltages of two bulbs:

- Th and Ng: Yeah, the rated power. But that power corresponds to the higher rated voltage
- Ng and Th: Yeah
- Ti: Hence, I can conclude that the high rated voltage ...
- Ng: ... But, if the bulb with the high rated voltage, it glows at the proper brightness. Well, now, the bulb which has the high rated power glows dimly, right? So these two factors are enough to affirm
- To: And how about the power consumed by the dim bulb ... ?
- Ng: The U, the bulb which has the high rated power glows dimly. Few moments ago, we measured it already. I saw it is dimmer than ...
- Ti: The rated voltage, OK! ... OK!
- Ng: Ah, is it? It is high. It glows dimly, right?
- Ti: If it is high, it glows dimly. How about ... ? So let's discuss the rated voltage ...
- Th: It depends on the ...
- Ng: Let's suppose that the power of the electrical source does not supply enough to ...
- Ti: ... the dim bulb ...

- Ng: ... to the rated voltage ... of the bulb. So it glows dimly
- Ti: So we conclude temporarily that the bulb glows dimly because the output voltage of the electrical source which supplies to it is lower than its rated voltage
- Ng: Yeah
- Ti: The dim bulb ...
- Th: Yeah, all right
- Ti: ... Read please. The output voltage of the power supply is less than the rated voltage of the dim bulb ... For the dim light bulb ...
- Ti: It causes the bulb to light up dimly ...

### The resolve

In this phase, students review their thinking and check the reasoning that has brought them to the conclusion that the difference in brightness is due to a difference in rated power.

As Ng states:

It demonstrates in the power, and the power that ... the power, all right! A while ago, we have concluded about the power. It means that the power of the bright bulb is lower than that of the dim one. We conclude nothing up to now. And now, we explain by relating with the rated power and the rated voltage. If the electrical source supplies some output voltage, which is equal to its rated voltage, the bulb will glow at its normal brightness according to the rating of the manufacturer

This phase not only leads to a new conclusion but also searches for implications in reality. As Ti questions: *Now, we buy two different bulbs, right? One is 6 V and other is 3 V. I question that how do we set up the circuit so that two bulbs glow at normal brightness? Two different circuits, all right?*

## Students' thoughts about learning

### Traditional learning science

It is clear from the student survey and interviews that students are not satisfied with the science content they learned in physics lectures because the traditional laboratory did not offer opportunities for students to bring abstract concepts learned in lectures to deal with everyday life practices. One student states: *In lecture, I studied some science concepts such as the oscillation of the current, the alternating current, and so on. I just understood that it is an oscillation, and I drew it on the paper. Nothing else.* One female student describes her feelings about the physics content in the following manner: *In lecture, I just heard the instructor telling us about some theoretical concepts such as the concentration, the polarization, the polarized solution, and so on. And we did not know that the sugar which we often see and use in reality has other characteristics.*

According to students' opinions, the traditional learning based on technical rationality is inappropriate to represent an authentic view of science. From technical rationalist point of view, mind is merely a mirror of nature. Teaching is conceptualized in terms of the conduit metaphor, according to which knowledge is simply transferred from a more proficient expert to a novice or a less knowledgeable individual. Physics concepts are often taught by using blackboard-and-chalk formats. Although lectures can be rivoting and engaging if conducted artfully, in many cases students rely on rote memorization for the sake of writing examinations. Critics have worried about the lack of meaningful learning taking place when due consideration is not given to practical, relevant contexts of inquiry in which students can learn to use their knowledge to make sense of phenomena and problems on their own. The traditional laboratory is regarded as the place where students simply verify well-known established laws or principles and acquire scientific skills. The goal of the teaching laboratory is to help students acquire scientific skills for future careers in physics. Yet, these skills, as



they are developed in schools, differ from those needed in reality. Students are very concerned with the grades rewarded for conforming to a teacher's view—the correct view. Students who have skills in memorization often receive good marks. But, students are rarely given experiences with the practices of everyday life, nor are they given the opportunity to pursue their own interests. There is no guarantee that students who receive good marks can deal with real-world problems better than students who receive low grades.

The traditional laboratory is regarded as a place where students just verify well-known established laws or principles, a form of re-memorization. In addition, the teaching laboratory is poor in certain areas of the country, and this, in part, has led to a rather “rhetorical” science education, that is, students have to rely heavily on memorization and lecture, sometimes at the expense of developing deeper understanding of the subject matter—the fundamental principles of science. Frequently, the need to learn by memorization is exacerbated by the lack of practical, concrete laboratory activities that are relevant and motivating for students.

### Learning by doing science

The following information taken from the student survey and interviews and student discussion on the video tape supports the notion that students acknowledged the usefulness of this approach in the teaching laboratory. One student states: ... *On the other hand, they helped us to experience science concepts learned by solving some realistic problems. For example, the “oscilloscope” experiment helped us to apply electrical sine wave concepts such as the amplitude, the frequency, the difference in phase, and so on. Particularly, through experimenting, we could see clearly and understand the actual and active sine waves of the voltage difference, and then ...* This opinion is from another student: *This experiment helps me to shape scientific concepts used in reality.* And another: *I found out that the rated power is precisely the consumed power which makes the bulb glow at normal brightness. Clearly stated, this experiment helps me shape factual knowledge and practical knowledge for the explanation of real-world phenomena.*

Students not only discover new meanings of science concepts or learn how principle apply to practical contexts, but they also acquire practical knowledge. The following excerpt illustrates the kind of procedural understanding students have developed in the course of solving this problem:

- Ti: Now, we separate them to experiment
- Ng: OK! Why not?
- Ti: Now, we separate them to test, OK?
- Ng: It means that we measure the voltage difference between two terminals of each bulb, right?
- Ti: Yeah! yeah, right ... We vary the applied voltage so that the bulb glows at normal brightness
- Ng: It is enough. It means that we measure the output voltage that makes the bulb glow at normal brightness. Ah ... uh, all right, OK ... OK, at normal brightness according to the rating of the manufacturer
- Ti: ... so that the bulb is white bright. It is all right!
- Ng: ... in order to test how does the voltage change?

They also construct new meanings of the science concepts:

- Ti: What is the rated power? Is it the consumed power? When we increase the consumed power until the bulb glows at normal brightness, right? In this case, that power is called the rated power, OK? But each bulb ...

A survey was designed to elicit students' attitudes toward science and this teaching approach. A total of 17 students completed the survey. 82% of students felt satisfied with this teaching approach, while the others were neutral. All students who completed the survey suggested that new experiments should be added to the physics laboratory. Further, they all agreed that this teaching approach helped them to develop deeper understandings of the concepts learned in physics lectures.

The students showed that laboratory work is an important aspect of learning science. It offered them opportunities to develop deeper understanding of abstract concepts covered in the

physics lectures and of practical knowledge covered during the laboratory activities. Through reflection-in-action, students discovered not only declarative but also practical aspects of doing and knowing physics. They also felt that learning by doing science in the physics laboratory could develop and shape their practical knowledge, make meaningful what they learned from lectures, and could fill the gaps which were left from the physics lectures. Consequently, there is a need to develop a science curriculum and a teaching laboratory that reflect the true nature of the scientific enterprise and the inter-relation among science, technology, and society. In short, there is a need for “authentic” science experience in the basic science education of students.

### Reflective learners

The participants—as prospective physics teachers—hope that they will bring experiences gained from this study to help their students develop more interest in science. The following comment illustrates this point: *As a prospective high school teacher, I will utilize electrical equipment, such as the oscilloscope, the electrical circuit in this “oscilloscope” experiment, to teach my students with the hope that they will be more positive toward science.* A similar opinion is expressed by another student: *As a prospective high school teacher, I feel that this teaching approach gave us teaching experiences for my future career.*

It is interesting to note that students look ahead to their future careers and make plans in the light of what they have practiced. In other words, as reflective learners, they bring their past experiences to their understandings of present experiences as well as their future plans.

### **Students’ thoughts about science**

The students’ thoughts toward science could be grouped in two aspects, a conceptual aspect, transmitted by textbooks and lectures, and a practical aspect, rooted in everyday life and laboratory activities.

### Declarative aspect

Students felt that concepts learned from textbooks and lectures were abstract and very different from everyday thinking. The following statement was typical of comments from students interviewed about conceptual aspects that they learned in the physics lecture course: *Before the lab course, I did not understand these concepts clearly, and I did not know how to apply them to deal with problems arose from real-world phenomena. They are just some things which I gained in everyday life practice.* Students recognize that factual knowledge is inappropriate to explain real-world phenomena. A male student says: *Yeah. And the other highest position where it moves back, and begins returning is equivalent with the maximum amplitude of the pendulum's oscillation studied in Math before. This is a real-world phenomenon. It is somewhat different from the theory in lecture.* From another response, he repeats: *But, in reality, the characters of the oscillations of the mango are dissimilar to those of oscillations in the theory.* While applying science concepts learned to explain the damped oscillation occurring on the computer, another student comments: *There are many damped oscillations appearing in reality. We study about the ideal oscillations in the lecture, but in reality, most of them are damped oscillations.*

The relationship of learning physics to practical knowledge was important to the students, but students did not experience this relationship in practice. They felt factual knowledge was secondary knowledge, the very limited scope of which did not allow them to gain deeper understandings about science concepts and to search for genuine knowledge.

### The practical aspect

The participants in this study saw this teaching approach as one which made explicit the relationship between science and everyday practice in two ways. First, through conducting experiments, the students could examine their experiences using science concepts that they were dealing with in their physics lecture. As one states: *Sir, to me, after practicing the*

*electrical and optical experiments, I would like to express my feelings about the "Wheatstone bridge" experiment. This experiment helps me shape scientific concepts in reality. Before the lab course, I did not understand these concepts clearly, and I did not know how to apply them to solve realistic some electrical problems.*

In addition, students were also aware of creating new meanings of science concepts, and of developing practical knowledge, through practice and inquiry to promote authentic science: *Through carrying out the "Wheatstone bridge" experiment, I found out that the rated power is precisely the consumed power which makes the bulb glow at normal brightness. Clearly stated, this experiment helps me shape factual knowledge and practical knowledge for the explanation of real-world phenomena.*

Students' dialogue recorded on the videotapes indicated that students attempted to open a window to link school knowledge with practical situations outside school. The following excerpt illustrates students' exertion in bringing practical knowledge that they had explored during their laboratory activities, for practices at school and those demonstrated by people while shopping, working in electrical stores, and so on: *Now, if we go shopping to buy two bulbs, one is marked 6 VDC, and other is marked 3.5 VDC. How do we supply the voltage difference to them so that they can glow at normal brightness?*

The survey indicated that all students recognized that this teaching approach helped them to gain experiences in explaining natural phenomena. All students agreed that, when taught this way, science is more authentic. In students' opinions, science occurs everywhere and is a fundamental part of everyday life practice.

Experience is basic for learning but reflection-in-action is the essential part of the learning process, as it results in both interpreting and extracting meaning from the experience. It is recognized that, this physics laboratory not only helped students learn science concepts, but also developed the practical knowledge. Students felt that this type of knowledge, in contrast to what they learned at school, was usable, helpful, and authentic. As for promoting authentic science, the researcher suggests that practices at school should be connected to social

and physical contexts from which students can develop complex practical skills similar to those that appear in the everyday practices of scientists and nonscientists alike.

### Practice versus science as a body of knowledge

The following information reveals that the students applauded the effectiveness of “practical affairs” in the teaching laboratory. It offers students opportunities to shape their misconceptions about the phenomenon and to gain more understanding about science concepts. One female student states: *Through experimenting, we were interested to explore the difference between the sugar used in everyday practice and the glucose used in the laboratory.* Similarly, another student says: *Sir, to me ... This experiment helps me to shape scientific concepts used in reality.* Expressing the same opinion as her friends, one female student recognizes: *In short, these experiments help me to explain everyday phenomena.*

The following excerpt illustrates the difficulty students experienced in making sense of the phenomena of interest, especially considering the fact that they had previously learned the pertinent theory in the lecture course. In the “Wheatstone Bridge” experiment, the students grappled with the problem in the following way:

Th: To me, the bulb is bright because the current splits to it more than ... that of the dim one. The current is higher

Ti: ... just judge so, just judge so ...

Ti: OK! I think that at first, the bulb is bright because its filament burns it up, right? The more it burns, the brighter it is, and the more luminous it is as well. We see, if the current which is flowing through it is higher, it is brighter. Because the current flows through it a lot, it creates more heat fiction. Therefore, it is more luminous. So, I agree with Th's opinion

Ng: It also emits heat, all right!

But, in contrast to the prior learning and discussion above:

Th: So we cannot conclude about the current

Ti: So, our conclusion is wrong. Recently, Th has said that  $I_b > I_d$ . Now, in reality,  $I_d > I_b$ , right?

According to the survey on students' attitudes toward science, 70.58% of students reported that theories are not absolutely true. All in all, the students felt unsatisfied with the notion that science is a body of knowledge that can "predict" and "govern" practical affairs. MacKinnon (1985) maintained that theory is used in the process of reflection-in-action but is neither the starting point nor the product of reflection. Rather, the starting point of reflection is practical knowledge applied in a specific case. As based on the prior practical knowledge gained from Ohm's law, participants in this study develop their practical knowledge by splitting the parallel circuit into two single ones to infer the current flowing through each light bulb. From the data gathered in on-the-spot experimentation, students construct new understandings of phenomena. In the "Wheatstone Bridge" experiment, the starting point of reflection did not lie in students' prior learning from the lecture, but came from the new meanings of concepts they constructed, from "seeing" the phenomenon in a way similar to that of the third question to derive the data in the mathematical form  $((I_d/I_b) < 1)$ . A plausible explanation for a problematic phenomenon may stem from practical knowledge and mathematics, and lead from reflection-in-action to further data collection, from experience to calculation. Accordingly, it is worth pointing out that scientific practices rely on both practical and conceptual knowledge, and depend on particular circumstances—the nature of problems, the phenomena, and so on. As an instructor, the researcher felt that this notion helps to broaden and to enrich the technical rationalist view about "theory-driven-practice." Accordingly, students will be more actively engaged in learning by doing science, and they will be more positive toward science. Yet, within the context of technical rationality, the familiar hierarchy is applied to the university curriculum in which practice is assigned the lowest value in the hierarchy and the highest status is assigned to theory and to those who conduct theory-building research (Munby and Russel, 1989, p. 72).

## Summary

This chapter has been concerned with whether Schön's analysis of reflection-in-action is applicable and appropriate for promoting learning of science in physics labs in Vietnam. Several themes have been developed in the analysis of data that reflect back on the problem statement and the research questions of this study. The first finding in this chapter showed how the analytic scheme was applied to the students' dialogue surrounding learning events recorded in the teaching laboratory. The analysis revealed a "reflective learning cycle," consistent with Schön's conceptualization of reflection-in-action. The concept of the reflective learning cycle was explored together with students' reflection on mathematical, declarative, and a practical aspects of physics knowledge in the practical situation. The cycle of reflection in learning consists of three phases: problem setting, reframing and resolve. In phase one, the problem is set. In subsequent reflective thought, information is gathered, the problem reframed, and conclusions and implications are derived for further experimentation. The process gives rise to new understandings about the phenomena investigated, to new meanings of science concepts, and to practical knowledge. Next, in Chapter Five, conclusions, discussion, and implications are put forth for this study.



## **Chapter 5**

### **Discussion**

This chapter begins with a review of the argument about the importance of learning in practice that has been crafted in this study. Second, the analysis of reflection-in-action, as it was seen to occur in the physics laboratory, is reviewed and the conclusions and limitations are put forward. Finally, implications raised by the study for further practice and research are discussed.

#### **Review of the argument**

The study began by criticizing the Technical Rationalist view as being insufficient for representing “authentic science.” The researcher supports the notion that a problem-solving focus in physics lab courses can help students learn to “see” phenomena in new ways, and to construct deep understandings of and science concepts and principles. It has been argued that this kind of approach to “authentic science” in Vietnamese physics teaching laboratories will be crucial to developing teaching approaches that allow students of the basic sciences to better understand science concepts and principles, as well as scientific phenomena that are related to every day practices.

The researcher reviewed pertinent position statements by Unesco, The Canadian Council, and some studies purporting to engage students in work on problematic tasks in authentic everyday contexts. The position statements are clear about the importance of engaging students in learning by doing and of developing representations of a more authentic view of science. But there are few studies which deal with university level teaching that draw on Schön’s (1983) ideas of learning through reflection-in-action, which is the central concern of this study.

In this research I have taken the position that “learning by doing science” is a process involving seeing familiar problems of practice in new ways which develop through reflection-in-action in open-inquiry, problem-centred laboratories. Schön’s (1983) conceptualization of reflection-in-action was tested in the context of a group of physics students’ activities and dialogue surrounding an electrical problem. The analysis focused on the categories of problem-setting, reframing, hypothesis-testing experiment, move-testing experiment, and exploratory experiment. In addition, the laboratory work was characterized in terms of a “reflective learning cycle” (MacKinnon, 1985). Thus, the dialogue and activities of the students, as they attempted to solve the electrical problem, were represented in terms of “initial problem-setting,” “reframing” and “resolve,” which are reviewed in more detailed below.

## Conclusions

On the basis of the data analysis presented in Chapter Four, several conclusions are offered here. Generally, Schön’s ideas provide a useful way to interpret how science students learn through the process of reflection-in-action (i.e., action and further thought generated by on-the-spot experimentation). One of the underlying themes of the study is that reflection is the interplay between problem-setting, reframing, and experimentation in the practice setting. The analysis of the data shows how problem-setting, reframing and experimentation can be seen to take place in the physics laboratory when a problem-solving approach is used.

The study has also demonstrated how an electrical experiment can be designed to encourage this kind of learning, although this has not been a primary focus of the work. The main upshot of the analysis is to demonstrate that the categories of reflection-in-action are rich enough to capture the quality of learning events in problem-solving activities. This task was identified in Chapter One as being the main focus of the study.

In the process of rendering this account, it has been argued that Schön’s ideas about reflection *are* applicable and appropriate for making sense of student learning in problem-

solving contexts. In order for this claim to be made, it was necessary for the categories of Schön's analysis of reflection-in-action to be "seen" in the discourse and actions of the group of four physics students as they conducted the "Wheatstone Bridge" experiment. The claim also requires that the categories have been used in a way that is consistent with Schön's scheme. In other words, the claim that reflection-in-action is, indeed, applicable and appropriate for making sense of learning by doing in "authentic" science contexts requires empirical evidence, together with a consistent and coherent argument. Through this research, I have concluded that Schön's scheme will be useful to my teaching, in terms of both designing laboratory activities to promote a more authentic kind of scientific activity in my teaching laboratory, and making sense of students' learning in such a context.

A significant finding of this study is that participants posed reflective questions in conceptualizing and solving problems on their own. This finding is put forward in response to the first specific research question, which asked, "How do students learn and apply science concepts to solve problems while doing their experiments?" The appropriate framing of a problem is central for effective problem-solving. Problem-setting and reframing are important skills in the complicated and confusing problems of everyday practices, in contrast to "paper and pencil" problems encountered in school textbooks, which are usually well-formed and which frequently exist in extremely limited practical contexts. According to some authors, in more traditional school settings students perceive themselves as having little or no control over either the problems or solutions that are studied (Schön, 1983; Roth, 1994). Such is more typically the case in the educational system of Vietnam, in which a soviet "didactic" influence, isolation from the professional science and science education communities, poor economic conditions, and a confucian-based society mitigate against meaningful learning, in favor of rote memorization.

A major contribution of this study is the fact that Vietnamese physics students were able to over-come these barriers, and enter into a context of inquiry and experimentation in a manner that was very unfamiliar to them, as affirmed by their testimonies in interviews and

student surveys. In the process of “finding the problem,” I argue that these students not only came to understand the electrical phenomena associated with the experiment more deeply, but that they also developed new (correct) understandings of the science concepts and principles involved.

Moreover, I believe, though there is not sufficient evidence for this claim in the present study, that problem-solving activity of this nature enables significantly more thorough and rigorous understandings of science than rote memorization, for it is in learning to “see” phenomena in particular ways that leads to solutions. Science concepts must be used in the contexts of inquiry and explanation in order to be deeply understood. In the absence of these contexts (i.e., reliance on rote memory), it is unlikely that such deep understandings will develop.

A couple of points should be made in response to the second specific research question, which asked, “What is the effect of this “authentic” science approach on students’ thoughts after the lab course about learning and science?” In regard to this question, data analysis revealed that students generally approved of the problem-solving approach and reported that they gained experiences that were useful in making sense of abstract concepts learned in their physics lectures. They felt they could make up problems of their own and redesign experiments they found interesting—a view of learning they put in contrast to the traditional laboratory, in which students felt they simply followed “cook book instructions” for replicating procedures and verifying well-known laws and theories.

In addition to commenting on the value of learning in a problem-solving context, students reported that they found this approach more relevant to their “everyday” lives, that they could “see more science around them.” Further, they felt that the activities they undertook in the laboratory were more aligned to what actually occurs in practising physicists’ laboratories. Finally, those participants who intended to become high school teachers themselves felt that they could use these and similar approaches to facilitate more meaningful learning among their own students in the future.

The conclusions are (1) that the analysis in this study has been faithful to Schön's work, and (2) that Schön's conceptualization of reflection-in-action provides an appropriate representation of learning in the context of "authentic" scientific practice.

### **Limitations**

The researcher realizes that the different cultures and languages of Vietnam and Canada contribute to a moderately serious limitation of this study. Some Vietnamese expressions are difficult to translate into English, and it must be appreciated that the meaning of transcribed and translated discourse can shift. Similarly, some English words used in education such as "constructivism" and "inquiry" are difficult to communicate to Vietnamese instructors. These may therefore restrict the interpretation of the author and readers alike. Another limitation to any study of reflection-in-action is the fact that students sometimes do not reflect on their own inquiry, and keep their intuitive understanding tacit. Detecting reflective thinking and learning is a highly inferential process.

It has been said that "qualitative research" provides precision, but not very much scope, while "quantitative research" provides scope, but less precision. Of course, there are good and bad studies in any genre of research, and it is clearly not the case that any one style is better than another. Research approaches and methods are chosen on the basis of their applicability to the research problems at hand. It should also be noted that any research can be limited by the bias of the researcher and his/her will to "see" things that might not be there.

### **Implications for practice**

Broadly speaking, this study has engaged the researcher in using Schön's conceptualization of reflection-in-action to develop new connections between the basic sciences and the applied sciences. Reflective thinking through "learning by doing" is a theoretical framework that has the capacity to enrich the science curriculum. It may help

teachers and students alike to see their learning in new ways. This researcher feels that the experience of conducting this study will have a long lasting influence on the way in which he makes sense of his own learning, both in the context of science and that of teaching science.

The problem-solving approach used in my teaching laboratory offers opportunities for students to engage in real-world phenomena and to search for genuine knowledge. It is suggested that the framework of this study should be extended to offer students opportunities to work on projects, so they become better prepared for the task of formulating their own problems, guided on the one hand by the general goals they set for themselves and, on the other hand, by phenomena they find interesting (Collins et al., 1989).

### **Implications for further research**

Although this study has yielded some insights about the utility of Schön's conceptualization of reflection-in-action in learning Physics in a problem-solving laboratory, further work is required to sharpen this model. The framework and approach could be tested in other experiments in the general physics laboratory courses in Vietnam and elsewhere. Further studies involving fields such as Mathematics, Biology, Chemistry, Political Science, Business, and Social Studies Education might also be conducted to explore the effectiveness of this style of teaching and learning.

The technique of video taping has proven to be very useful in this study and would be strongly recommended, both to other scholars who have an interest in researching their teaching, and for any future research I undertake in my teaching laboratory. In future work, it may be worth bringing a team of researchers together to analyze and discuss the video tapes. Certainly, this kind of approach has great potential for bringing international scholars and interests together. Not only would such a measure enhance the dissemination of research, but it would serve to sharpen and illuminate the analysis.

## Bibliography

- AAAS (1965). An evaluation model and its application. In *Science—A process approach* (AAAS Miscellaneous Publication 65-69).
- Brown, J.S., Collins, A., and Duguid, P. (1989). Situated cognition and the culture of learning. *Educational Researcher*, 18 (2), 32-42.
- Candy, P.C. (1990). How people learn to learn. In R.M. Smith, *Learning to learn across the life-span*. San Francisco: Jossey-Bass.
- Candy, P.C. (1991). *Self-direction for life long learning*. San Francisco: Jossey-Bass.
- Clarke, A. (1994). Student-Teacher Reflection: Developing and Defining a practice that is uniquely one's own. *International Journal of Science Education*, 16 (5), 497-509.
- Dewey, J. (1933). *How we think*. New York: Heath and Company.
- Duit, R. (1995). *Learning Science in the schools: research reforming practice*. Mahwah, N.J.: Erlbaum Associates.
- Edmondson, J., Novak, K. (1993). The Interplay of Scientific Epistemology Views, Learning Strategies, and Attitudes of College Students. *Journal of Research in Science Teaching*, 30 (6), 547-559.
- Feynman, P.J. (1985). *Surely, You're Joking Mr. Feynman*. New York: Bantam Books.
- Gagné, R.M. (1967). *Science—A process approach: Purpose, accomplishments, expectations*. Washington, DC: Commission on Science Education, Association for the Advancement of Science.
- Gagné, R.M. (1970). *The conditions of learning* (2<sup>nd</sup> ed.). New York: Holt, Rinehart and Winston.
- Gagné, E.D. (1985). *The Cognitive Psychology of School Learning*. Toronto: Little, Brown and Company.
- Gallagher, J.J., and Tobin, K. (1987). Teacher management and student engagement in high school science. *Science Education*, 71, 535-555.
- Gilbert, J. (1994). The construction and reconstruction of the concept of the reflective practitioner in the discourses of teacher professional development. *International Journal of Science Education*, 16 (5), 511-522.
- Gould, S.J. (1989). *Wonderful life: The Burgers Shade and the nature of history*. New York: W.W. Norton
- Hammer, D. (1994). Students' belief about conceptual knowledge in introductory physics. *International Journal of Science Education*, 16 (4), 385-403.
- Haré, R. (1985). *The Philosophy of Science*. 2<sup>nd</sup> Edition. Guernsey: The Guersy Press.

- Heath, S.B, McLaughlin, M.W. (1994). Learning for anything everyday. *Journal of Curriculum Studies*, 26 (5), 471-489.
- Held, D. (1980). *Introduction to Critical Theory: Horkeimer to Habermas*. Berkeley: University of California Press.
- Hills, P.J. (1976). *The Self-Teaching Process in Higher Education*. London: Croom Helm.
- Hodson, D. (1996). Laboratory work as scientific method: three decades of confusion and distortion. *Journal of Curriculum Studies*, 28 (2), 115-135.
- Jenkins, E.W. (1996). The 'nature of science' as a curriculum component. *Journal of Curriculum Studies*, 28 (2), 137-150.
- Kelly, G.J., Crawford, T. (1996). Students' Interaction with Computer Representations: Analysis of Discourse in Laboratory Groups. *Journal of Research in Science Teaching*, 33 (7), 693-707.
- King, P.M. (1992). How do we know? Why do we believe? Learning to make reflective judgments. *Liberal Education*, 78, (1), 2-9.
- Knorr-Cetina, K.D. (1981a). *The manufacture of knowledge: An essay on the constructivist and contextual nature of science*. Oxford: Pergamon Press.
- Knorr-Catina, K.D. (1981b). Social and scientific method or what do we make of the distinction between the natural and the social science? *Philosophy of Social Science*, 11, 335-359.
- Kritt, D. (1993). Authenticity Reflection, and Self-evaluation in Alternative Assessment. *Journal of Middle School*, 43-45.
- Larsson, S. (1986). Learning from experience: Teachers' conceptions of changes in their professional practice. *Journal of Curriculum Studies*, 19, (1), 35-43.
- Latour, B. (1987). *Science in action: How to follow scientists and engineers through society*. Milton Keynes: Open University Press.
- Lawson, A., Abraham, M., Renner, J. (1989). *A Theory of Instruction: Using the Learning Cycle to Teach Science Concepts and Thinking Skills*. NARST Monograph, Number one
- MacKinnon, A. (1985). *Reflection among Perspective Teachers*. Unpublished Master Thesis, University of Calgary.
- MacKinnon, A. (1989). *A "Reflective Practicum" in Constructivist Science Teaching*. Unpublished doctoral dissertation, University of British Columbia.
- Martin, B., Kass, H., and Brouwer, W. (1990). Authentic Science: A Diversity of Meanings. *Science Education*, 74 (5), 541-554.
- McMillan III, C., Swadener, M. (1991) Novice Use of Qualitative Versus Quantitative Problem Solving in Electrostatics. *Journal of Research in Science Teaching*, 28 (8), 661-670.



- McMillan, J. (1993). *Research in Education: A conceptual introduction*. 3<sup>rd</sup> Edition. New York: Harper Collins College Publishers.
- Munby, H., and Russel, T. (1989). Educating the reflective teacher: An essay review of two books by Donald Schön. *Journal of Curriculum Studies*, 21, (1), 71-80.
- National Society for the Study of Education (1995). *Improving Science Education*. Chicago: The University of Chicago Press.
- Nevins, K.J. (1992). Understanding Students as Learners: Using Student Development Models. *Liberal Education*, 78 (1), 24-27.
- Philip, B. (1991). *Experiential learning in action*. Great Britain: Atheneum Press.
- Phil, C. (1996). *Critical Ethnography in Education Research: Theory and practice guide*. New York: Routledge.
- Renner, J.W. (1984, August). Two theories of learning: In one we believe, the other we use. *Chemtech*, 462-467.
- Rigano, D., Ritchie, S. (1996). Laboratory Apprenticeship through a Student Research Project. *Journal of Research in Science Teaching*, 33 (7), 799-815.
- Ross, J. (1982). *Teaching Problem-Solving*. Ontario: The Ontario Institute for Studies in Education.
- Roth, W.-M., Roychoudhury, A. (1993). The Development of Science Process Skills in Authentic Contexts. *Journal of Research in Science Teaching*, 30 (2), 127-152.
- Roth, W. -M. (1994). Experimenting in a Constructivist High School Physics Laboratory. *Journal of Research in Science Teaching*, 31 (2), 197-223.
- Roth, W.-M. (1996). Teacher Questioning in an Open-Inquiry Learning Environment: Interaction of Context, Content, and Students Responses. *Journal of Research in Science Teaching*, 33 (7), 709-736.
- Rubin, R.L., and Norman, J.T. (1992). Systematic Modeling versus the Learning Cycle: Comparative Effects on Integrated Science Process Skill Achievement. *Journal of Research in Science Teaching*, 29 (7), 715-727.
- Schön, D. (1974). *Theory in Practice: Increasing Professional Effectiveness*. California: Basic Books.
- Shön, D. (1983). *The Reflective Practitioner: How professionals think in action*. New York: Basic Books.
- Shön, D. (1987). *Educating the reflective practitioner: Toward a new design for teaching and learning*. New York: Basic Books.
- Schön, D. (1991). *The Reflective Turn: Case Studies in and on Educational Practice*. New York: Teachers College Press.

- Science Council of Canada (1984). *Science for Every Student: Educating Canadians for Tomorrow's World*. Council Report No 36. Hull, Quebec: Minister of Supply and Services.
- Strange, C. (1992). *Beyond the Classroom: Encouraging Reflective Thinking*. *Liberal Education*, 78 (1), 28-32.
- Tamir, P. (1989). Training teachers to teach effectively in the laboratory. *Science Education*, 73, 59-69.
- Tobin, K.G. (1990b). Research on science laboratory activities: In pursuit of better questions and answers to improve learning. *School Science and Mathematics*, 90, 403-418.
- Thurber, W., Collette, A. (1967). *Teaching Science in Today's secondary schools*. 2<sup>nd</sup> Edition. Boston: Allyn and Bacon.
- UNESCO. (1986) *Innovations in science and technology education*. Vol. 1. Belgium: Impimerie GEDIT, Tournai.
- UNESCO. (1988) *Innovations in Science and Technology Education*. Vol. 2. Belgium: Impimerie GEDIT, Tournai.
- UNESCO. (1985). *Science and Technology in countries of Asia and the Pacific*. Vol. 52. Paris, France: Workshops of UNESCO.
- UNESCO. (1990). *New trends in integrated science teaching*. Vol. 6. Paris, France: UNESCO.
- Wheatley, G.H. (1991). Constructivist perspectives on science and mathematics learning. *Science Education*; 75 (1), 9-21.
- Whitaker, Patrick, W. (1995). *Managing to learning: Aspects of reflective learning and experiential learning in schools*. Great Britain: Guildford and King's Lynn.
- Wilson, J., and Jan, L.W. (1993). *Thinking for themselves: Developing strategies for Reflective learning*. Portsmouth: Heinemann.
- World Education Service. (1994). *Education in Vietnam*.
- Zajchowski, R., and Martjn, J. (1993). Differences in the Problem Solving of Stronger and Weaker Novices in Physics: Knowledge, Strategies, or Knowledge Structure? *Journal of Research in Science Teaching*, 30 (5), 459-470.

## Appendix I

### Letter of Permission

Dr. Tran Phuoc Duong  
Rector of Cantho University  
Cantho Province, Vietnam

Dear Sir:

I have proposed a thesis as part of my science education program at S.F.U. My topic is "A teaching innovation to promote the authentic science in Vietnamese Universities," and the question I am hoping to answer is: How do the students apply science concepts to solve the problem arose from authentic everyday life experiments? I am proposing to conduct this investigation in the physic lab, for second year science students.

I am requesting your help in assigning me to teach the physic lab course, and to approve this course as source data for my thesis. I would then like to record activities and conversations with a group of students while they undertake an electrical experiment, and conduct a follow-up interview with them about electrical phenomena, and various applications of electricity in their daily lives, their thoughts about science and toward learning. To give you further information about my research project, a copy of my proposal translated into Vietnamese is included.

I would also forward another letter to Dr. Tran Thuong Tuan, Vice Rector of Cantho University to submit my project, and gradly meet Dr. Le Phuoc Loc, Dean of Faculty of Education, Mr. Dang Van Hiep, Head of Physics Department to show my proposal and ask them for help about the possibility of using physics lab as a source of collecting the data.

Thank you for considering this matter. I would like to look forward to hearing from you.

Sincerely,

Ho Huu Hau

## Letter of Permission

Dr Tran Thuong Tuan  
Vice Rector of Cantho University  
Cantho Province, Vietnam

Dear Sir:

I have proposed a thesis as part of my science education program at S.F.U. My topic is "A teaching innovation to promote the authentic science in Vietnamese Universities," and the question I am hoping to answer is: How do the students apply science concepts to solve problems arose from real-world phenomena while conducting experiments? I am proposing to conduct this investigation in the physics lab, for second year science students.

I am requesting your help in assigning me to teach the physic lab course, and to approve this course as source data for my thesis. I would then like to record activities and conversations with a group of students while they undertake an electrical experiment and conduct a follow-up interview with them about electrical phenomena and various applications of electricity in their daily lives, their thoughts about science and toward learning. To give you further information about my research project, a copy of my proposal translated into Vietnamese is included.

I would also forward another letter to Dr. Tran Phuoc Duong Rector of Cantho University to submit my project and gradly meet Dr. Le Phuoc Loc, Dean of Faculty of Education, Mr. Dang Van Hiep, Head of Physics Department to show my research project and ask them for help about the possibility of using the physics lab as a source of collecting the data.

Thank you for considering this matter. I would like to look forward to hearing from you.

Sincerely,

Ho Huu Hau

## SIMON FRASER UNIVERSITY

VICE-PRESIDENT, RESEARCH

BURNABY, BRITISH COLUMBIA  
CANADA V5A 1S6  
Telephone: (604) 291-4152  
FAX: (604) 291-4860

March 14, 1996

Mr. Ho Huu Hau  
Graduate Student  
Education  
c/o Allan MacKinnon  
Simon Fraser University

Dear Mr. Hau:

**Re: A Teaching Approach to Promote "Authentic Science"**

I am pleased to inform you on behalf of the University Research Ethics Review Committee that the above referenced Request for Ethical Approval of Research has been approved contingent upon this office receiving a letter of acknowledgment and approval from Cantho University in Cantho Province, Vietnam authorizing your research to be conducted. Once this letter has been received by this office, you may proceed with your research.

This approval is in effect for twenty-four months from the above date. Any changes in the procedures affecting interaction with human subjects should be reported to the University Research Ethics Review Committee. Significant changes will require the submission of a revised Request for Ethical Approval of Research. This approval is in effect only while you are a registered SFU student.

Best wishes for success in this research.

Sincerely,

A handwritten signature in cursive script, appearing to read "B. Clayman".

*for* Bruce P. Clayman, Chair  
University Research Ethics Review Committee

c: Allan MacKinnon, Supervisor  
P. Winne

BR/hme

BỘ GIÁO DỤC VÀ ĐÀO TẠO  
TRƯỜNG ĐẠI HỌC CẦN THƠ  
Số : 382/HCTH.96

CỘNG HÒA XÃ HỘI CHỦ NGHĨA VIỆT NAM  
Độc lập - Tự do - Hạnh phúc

Cần thơ, ngày 7 tháng 5 năm 1996

## NHẬN XÉT CỦA HIỆU TRƯỞNG

Anh Hồ Hữu Hậu đã hoàn thành tốt công tác thu thập tư liệu cần thiết cho đề tài luận văn tốt nghiệp của anh tại Đại học Simon Fraser.

Anh Hậu đã làm việc nghiêm túc với phương pháp mới. Đề tài của anh sẽ có tác dụng tốt cho công tác giảng dạy lý thuyết và thực tập Vật lý tại Trường Đại học Cần thơ.

HIỆU TRƯỞNG TRƯỜNG ĐẠI HỌC CẦN THƠ

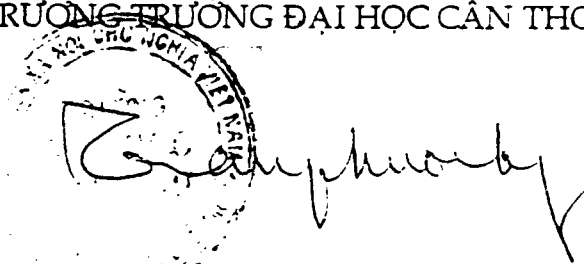

Gs. TRẦN PHƯỚC ĐƯỜNG

## Appendix II

### Letter for cooperation and assistance

Dear students:

As in an effort to complete the research project regarding as an account of a teaching innovation to promote "authentic" science in Vietnamese Universities, I would greatly appreciate your participation and assistance in this study. Your participation is voluntary and your responses are important to obtain a representative sample.

You will be undertaken the "Wheatstone Bridge" experiment, and conducted a follow-up interview about electrical phenomena and various electrical applications in your daily life. A video tape will record your activities and conversations as a source data for my thesis. In addition, you will receive a list of questionnaires asking your thoughts about science and toward this teaching approach.

This study is independent of Faculty of Education, Cantho University. If you have any questions about this research project, please not hesitate contact with Dean of Education Faculty, Simon Fraser University, Dr. Robin Barrow, (604) 291-3148, or my professor, Dr. Allan Mackinnon, (604) 291-3432.

Along with this letter, please read the following informed consent letter, to sign on if you agree to participate in this project.

Thank you for your cooperation.

Ho Huu Hau  
Master student of Simon Fraser University  
Burnaby, BC, Canada

**SIMON FRASER UNIVERSITY**  
**Informed Consent by Subjects**  
**To Participate in a Research Project**

Having been asked by Ho Huu Hau, graduate student in the Faculty of Education at Simon Fraser University, to take part in a research project, I agree to participate in the form of a personal interview conducted by the above-named researcher regarding as a teaching innovation to promote "authentic" science.

The interview or student survey will take place at

\_\_\_\_\_

on \_\_\_\_\_

I understand:

- a) the procedure used in this research project
- b) that I may withdraw my participation, in part or in full, at any time
- c) that my responses will be maintained in strict confidence
- d) that I will remain anonymous in any written reports resulted from this study
- e) that the interview and video tape will be destroyed upon completion of the study
- f) that I may register any complaint I might have about the research project with Dean of Education Faculty, Simon Fraser University, Dr. Robin Barrow, (604) 291-3148
- g) that I may receive a copy of the thesis from Dr. Allan Mackinnon, (604) 291-3432, or Ho Huu Hau, if I choose

NAME (Please print): \_\_\_\_\_

ADDRESS: \_\_\_\_\_

SIGNATURE: \_\_\_\_\_



## Sample of Survey

Dear Students:

In an endeavor to answer the research question: what is the effect of this "authentic" science approach on students' thoughts toward science and about learning?, I would greatly appreciate your cooperation to complete the following attached survey. Your participation is voluntary and your response is important to obtain a representative sample.

This study is independent of Faculty of Education, Cantho University. If you have any questions about this project, please contact with Dean of Faculty Education, Simon Fraser University, Dr. Robin Barrow, (604) 291-3148, or my professor Dr. Allan Mackinnon, (604) 291-3432.

The survey will take ten minutes or less to complete and I would like to get the survey returned by 22 April. You may drop the survey in the mail box of Math and Physic Faculty or contact directly with me whenever if it is possible.

Thank you for your cooperation.

Ho Huu Hau  
Master student of Simon Fraser University, Canada

Lecturer of Math and Physics Faculty

Cantho University, Vietnam

**Instructions:**

Please answer each of the following questions

Please use this key for response

1= Strongly agree

2= Moderately agree

3= No idea

4= Moderately disagree

5= Strongly disagree

(circle one number in each category)

- |    |   |   |   |   |   |   |
|----|---|---|---|---|---|---|
| 1. | Science denotes a generalized prestige as scientific history, a scientific analysis of modern art   | 1 | 2 | 3 | 4 | 5 |
| 2. | Science is a body of verified knowledge as Biology, Chemistry, Physics and so on  | 1 | 2 | 3 | 4 | 5 |
| 3. | Science connotes an objective analysis of phenomena   | 1 | 2 | 3 | 4 | 5 |
| 4. | Science is viewed as a set of socially negotiated understandings of the events and phenomena that comprise the experienced universe                       | 1 | 2 | 3 | 4 | 5 |
| 5. | Science is laws or principles that can be tested experimentally   | 1 | 2 | 3 | 4 | 5 |
| 6. | Science is applicable to the widest possible variety of phenomena   | 1 | 2 | 3 | 4 | 5 |
| 7. | One of the major goal of science is a search for understanding, for the revelation of underlying pattern in some complex and confusing aspects of reality | 1 | 2 | 3 | 4 | 5 |

- |  |   |   |   |   |   |
|--|---|---|---|---|---|
| 8. Science is important  | 1 | 2 | 3 | 4 | 5 |
| 9. You are satisfied with this approach                                      | 1 | 2 | 3 | 4 | 5 |
| 10. This approach could be made better                                       | 1 | 2 | 3 | 4 | 5 |
| 11. You believe absolutely whatever you studied on the lecture courses       | 1 | 2 | 3 | 4 | 5 |
| 12. What can be observed exists  | 1 | 2 | 3 | 4 | 5 |
| 13. Experiments can help you have more experience to explain daily phenomena | 1 | 2 | 3 | 4 | 5 |
| 14. This approach could be extended to other areas of science                | 1 | 2 | 3 | 4 | 5 |

To classify your responses, please tell a little bit of your personal information:

Sex:            Male \_\_\_\_\_

                  Female \_\_\_\_\_

Faculty: \_\_\_\_\_

Level of study:

First year \_\_\_\_\_

Second year \_\_\_\_\_

Third year \_\_\_\_\_

Fourth year \_\_\_\_\_

GPA:

Above 5.0 \_\_\_\_\_

5.0 to 7.0 \_\_\_\_\_

7.0 to 10 \_\_\_\_\_

less than 5.0 \_\_\_\_\_

Please write briefly about your opinions toward science

---

Please write briefly your opinions toward this approach

---

Additional comments:

\_\_\_\_\_

Name: \_\_\_\_\_

Signature: \_\_\_\_\_

Date: \_\_\_\_\_

## Interview questions

1. By the way you are taking break, I would like to interview your opinion about this teaching approach which you undertook, and toward science. Would you please let me know your opinions about these electrical and optical experiments after lab course? Are these experiments useful? Please explain why?
2. Would you show me some another opinions?
3. Would you satisfy these experiments? Please explain why?
4. Could you please show and explain some examples about phenomena occurring in your daily life and in reality?
5. Now, could you please demonstrate simple phenomenon of electrostatic interaction, that of the magnetic interaction, and so on?
6. What would you conclude about the space around the pen?
7. Could you show a phenomenon of magnetic interaction? Would you observe which direction it turns?
8. Could you explain this phenomenon?
9. What is that medium?
10. What is your conclusion about the cause creating the magnetic field?
11. Would you please show me some applications of SI units which we often use in your daily life and in reality?
12. Suppose that you have a radio or a cassette player rated at 6VDC. What does it mean?
13. How do you use to satisfy the rated voltage of the cassette player?
14. Now, suppose that you have a bulb having the voltage rated at 6VDC and the power rated at 1W. How many volts do you offer for the bulb? And how many amperes do the current flow through the bulb?
15. What kind of the energy does that power convert?
16. Would you show me a subsequent phenomenon that occurs more naturally surrounding us?
17. Would you please show me the relationship between the amplitude of the simple harmonic motion with that of the electro-magnetic oscillation?
18. What would you comment about the mechanical oscillation and its relationship with the electro-magnetic oscillation? How about its phase? How about its initial phase?

19. How about its amplitude?
20. How many degrees for the initial phase?
21. What would you comment about two oscillations?
22. How many?
23. What would you comment about these two simple harmonic motions?
24. What would you comment about the superposition of these two simple harmonic motions?
25. What would you comment about these two sin oscillation?
26. What do you think about this angle? What would you observe about superposition curve?
27. In case of 180 degrees, what is going on?
28. These are curves of three simple harmonic motions. Would you show their applications in reality?
29. Would you let me know what this oscillation is? Is it damped oscillation?
30. Could you relate this oscillation with some damped occurring in reality?
31. Would you compare the relationship between some mechanical oscillatory quantities with the electro-magnetic quantities in physics? Please explain this case
32. How about the electric energy?
33. How about the magnetic energy?
34. Could you please explain the conversion between the electric energy and the magnetic energy to form the sin wave?

## Appendix III

### Interview Transcription

- 1 In: By the way you are taking break, I would like to interview your opinions about experiments, your thoughts toward science and about learning after lab course. OK! Would you let me know your opinions about experiments which you undertook during lab course? Are they useful? Please explain why?
- 2 S1: Sir, I would like to represent our group to answer this question. To us, these experiments are very interesting. They helped us to test and to believe what we studied in lecture. On the other hand, they helped us to experience science concepts learned for solving some realistic problems. For examples, the "oscilloscope" experiment helped us to apply electrical sine wave concepts such as amplitude, frequency, phase and so on ... Particularly, through experimenting, we could see clearly and understand the actual and active sine waves of the voltage difference, and then ... As prospect high school teachers, I feel that this teaching approach gives us teaching experiences for my future career
- 3 S2: Sir, as I and Tu worked in group to conduct the "oscilloscope" experiment, I would like to show my own opinion about the lecture course. In lecture, I studied some science concepts as the oscillation of the current, the alternating current, and so on. I just understood that it is an oscillation, and drew it on the paper. Nothing else. But through experimenting the "oscilloscope" experiment with the actual electronic circuit and the oscilloscope, I could observe the real sin curve generated from the actual electrical circuit on the screen of the oscilloscope. Hence, I would rather be more positive toward science than I was before. As a prospect high school teacher, I will utilize electronic equipment such as the oscilloscope, the electrical circuit in this "oscilloscope" experiment to teach my students with the hope that they will be more positive toward science
- 4 In: I appreciate your opinion. Would you show me some another opinions?
- 5 S: Sir, well, I'd like to show you some opinions about the "glucose meter" experiment. In lecture, I just heard the instructor telling about some theoretical concepts such as the concentration, the polarization, the polarized solution, and so on. And we did not know that the sugar which we often see and use in reality has another characteristics. Through experimenting, we were interesting to explore the difference between the sugar used in everyday life practice and the glucose used in laboratory. In short, after lab course, we can understand clearly what is learned in lecture
- 6 In: Would you have some another opinions?
- 7 S7: No, sir
- 8 In: Would you show another opinions about experiments which you undertook?



- 9 S: Sir, to me, after practicing the electrical and optical experiments, I would like to show my feelings about the "Wheatstone Bridge" experiment. This experiment helps me shape scientific knowledge used in reality. Before lab course, I did not understand these concepts clearly, and I did not know how to apply them to deal with problems rose from real-world phenomena. solve realistic problems. They are just some things which I gained in everyday life practice. Through experimenting the "Wheatstone Bridge" experiment, I found out that the rated power is precisely the consumed power making the bulb glow at normal brightness. Clearly stated, this experiment helps me shape factual knowledge and practical knowledge for the explanation of real-world phenomenon. On the other hand, as a prospect teacher, I also feel that ... through this teaching approach, I gained some teaching experiences in order to know how I can do, how I can teach ... to help my students understand and believe ... generally speaking, what they learn in theory. To my own opinion, this experiment provided us opportunities to strengthen our scientific knowledge learned in lecture. That is my opinion about that
- 10 In: Thank you. I would like to ask you another question. Would you satisfy these experiments? Please explain why?
- 11 S: Sir, I am very pleasant about these experiments. After lab course, I feel more positive toward science. Through practicing these experiments, I developed practical knowledge to explain real-world phenomenon. But I think there remains many abstract sections in the physic curriculum such as interference, diffracting grating, the motion of electron or some thing like that. We have not experienced them yet in lab course. I suggest that more experiments for the application of these science concepts should be added to lab course for students of later course with the hope that theses experiments will promote students' understanding about science. In short, these experiments help me to explain everyday life phenomena
- 12 In: Thank you for your opinion. You said that after undertaking this lab course, you can utilize scientific knowledge learned in lecture to explain everyday life phenomenon. OK! Could you show me some examples?
- 13 To: Sir, generally speaking, there are many of real-world phenomenon occurring around us. And particularly speaking, they relate to physics areas such as electricity, optics and mechanics. For examples, thunder bolt, rain-bow, oscillating leaves on the branch, falling leaves, the branch of the tree oscillating by the wind, the phenomenon of the electrostatic interaction, and those of the magnetic interaction, and so on
- 14 In: Now, could you give a demonstration relating to the electrostatic interaction? OK! T, show me please. Now, let's come to that table to observe T's presentation
- 15 T: Sir, my demonstration is an electrostatic phenomenon ... This is my pen. Supposing that my pen is some thing like a plastic stick. I rub my pen on my hairs like this. I then put it near some small pieces of paper. You see that it attracts these pieces of paper. This is the phenomena of the magnetic interaction. No, I am sorry, the phenomenon of the electrostatic interaction
- 16 In: What would you conclude about the space around the pen?

- 17 T: Sir, before concluding about that, please let me explain it clearly. It is ... while rubbing the pen on my hairs, the pen is charged. There are electrons moving in them. And according to characters of the pen, charges on both the pen and the paper may be positive or negative. For easy explanation, I suppose that one terminal of the pen gets positive charges, and one surface of small pieces of the paper get negative charges ... When putting the positive terminal of the pen close to these small pieces of the paper which are neutral at the beginning. And as you see, positive charges on the pen attract the negative charges on the paper. These can be explained as the following. Negative charges on the paper move to concentrate on one surface of the paper near the pen. Clearly speaking, these pieces of paper are charged by induction. Accordingly, this phenomenon is called the phenomenon of the electrostatic interaction. Now, I utilize the theory learned to explain this phenomenon. This is the theory of the electrostatic interaction. Sir ... while ... According to the theory of the electrostatic interaction, two same charges are impulse. And two different ones attract to each other ... Thus, positive charges on the pen and negative charges on the paper attract to each other
- 18 In: What would you conclude about the space around the pen?
- 19 T: As seeing, these pieces of the paper fly toward the pen. This phenomenon make me arise one question. Is there any special media which exists around the pen and the paper? And does this media cause electrical forces on charges? In order to answer these questions, scientists defined it electromagnetic field
- 20 T: Electric field
- 21 T: Yes, electric field
- 22 In: Now, could you please show another phenomenon related to magnetic interaction? OK! Now, I show you a simple demonstration about that. This is a compass needle. First, putting it near the U magnetic bar, it is deflected, right? Now, let's experiment with a 18 V battery to have the current flowing through the wire. We see that it deflects as well, right. Now, I change terminals of the wire, would you observe which direction does it deflect?
- 23 S: In opposite direction
- 24 In: Good, in opposite direction. Now, could you explain this phenomenon? By the way, I would give you another demonstration like this. Here is the U magnetic bar, right? And this is a small magnetic bar. You see that the small one is rotating, and changing its poles. It then is attracted by the big one. Could you explain this phenomenon?
- 25 T: Sir, I'd like to explain this phenomena. According to this demonstration, I recognize that it is the phenomenon of magnetic interaction. Now, the phenomenon of magnetic interaction occurs as the following. For easy explanation, I suppose that there are currents existing in two wires putting close together in parallel. And I also suppose that their intensities are high enough to ... And the distance between them should be small. These two wires would impulse if two currents are in the same direction. And two wires would attract to each other if the currents flowing through them are in opposite direction. But as we do not have this experiment, I just only talk about that. Normally, the compass needle is always in the northern and southern direction according to the

electromagnetic field of the earth. This is a phenomenon occurring in reality. Now, we move and turn the wire in parallel with the compass needle. OK! in this case, there is nothing happen. Now, we connect two terminals of the wire to those of the battery to have the current flowing along this direction. We see that the compass needle deflects like this. Now, I alter two terminals of the battery in order to change the direction of the current, you see that the compass needle deflects in the opposite direction. The cause of these deflections can be explained like the following. When the current flows through the wire, it creates some medium in the space around the wire. And this medium creates a force making the compass needle deflect. This medium is termed some field named magnetic field. It depends on the ... this medium is symbolized by magnetic field vectors, it depends on the direction. Saying exactly ... therefore ... if we make the current in the wire flow along some direction, we see that the compass needle turns forward like this ... Now, if I alter the direction of the current, we see that the compass needle turns reversely. From this experiment, I believe that there is some medium existing around the wire. This medium is called the magnetic field ... Now, I present the second demonstration. Here is a magnetic bar. It also creates some medium in the space around it. And when we ... Normally, we see nothing happen. Now, we move the magnetic bar near to the compass needle. We see that it deflects. Similarly, I reverse two poles of the magnetic bar, moving it near to the compass needle, we also see that the compass needle turns in the reverse direction. Exactly saying, there is some medium in the space around the magnetic bar that makes the compass needle deflected

26 In: What is that medium?

27 S: Similarly, we have two magnetic bars which interact to each other. Supposing that we have the U magnetic bar and a small magnetic bar. The phenomena occurs similarly. Putting this magnetic bar near one terminal of the other one, we see that they attract to each other. Putting it here, it is attracted by the other as well. According to this experiment, I think that there is a medium existing in the space around the magnetic bar. This medium is termed magnetic field. Before this demonstration, I do not believe that there is a medium existing like this ... Now, after experimenting, I strongly believe about that. And this medium creates attractive forces to make these magnetic bars move to each other

28 In: I have another question. How about your conclusion about the cause creating the magnetic field? First, the current creates the magnetic field ... this is the wire, right? We connect two terminals of the wire to the battery to have the current flowing through the wire. We see that the compass needle turns. Now, we put the magnetic bar near the compass needle, we see that it is turned as well. What is the cause creating the magnetic field in this case? Current, right?

29 S1: The cause creating the magnetic field ... basing on the first demonstration, we see that when the current flows through the wire, it creates the magnetic field in the space around the wire. Therefore, the cause creating the magnetic field is the current. We can explain exactly that the flow of the moving electrons in the wire is the cause to create the magnetic field in the space. And this current ... the medium is created by this current. It is the microscopic current

30 S2: No, normal current

31 S1: Microscopic current

- 32 S4: No, the normal current
- 33 S1: The normal current. This magnetic bar creates the magnetic field in the space around it as well ... and this magnetic bar ... Finally, in conclusion, the cause creating the magnetic field is the flow of moving charges
- 34 In: Now, would you show me some applications of SI units which we often use in reality?
- 35 S: In Physics, we often use the SI units. We use the ohm unit to indicate the resistance, the ampere unit to measure the current, and the volt unit to measure the voltage difference
- 36 In: Volt unit. OK! Now, suppose that you have a radio or a cassette player rated at 6 VDC, what does it mean?
- 37 S: The voltage difference is 6 V?
- 38 In: How do you satisfy the voltage rated for the cassette player?
- 39 S: If the cassette player has the voltage rated at 6 VDC, we use the 6 VDC power supply or the batteries with 6 VDC. If we use 1.5 V battery, we have to connect four batteries to form a 6V battery
- 40 In: Now, suppose that you have a bulb with the voltage rated at 6 V, and the power rated at 1 W. How many volts do you offer for the bulb? And how many amperes do the current flow through the bulb?
- 41 S: The 6 V bulb?
- 42 In: The bulb has the voltage rated at 6 V and the power rated at 1 W
- 43 S: So we use the electrical source with the 6 VDC for the bulb. Certainly, it can glow at normal brightness. And the power rated at 0.5 W means that the current ... the bulb consumes 0.5 J per second
- 44 In: What kind of energy does that power convert?
- 45 S7: That consumed power converts to heat energy and luminous energy
- 46 In: I appreciate your opinions. Now, would you show me a subsequent phenomena that occur more naturally? It may be surrounding us ... Could you find it?
- 47 S2: How about the phenomenon of the simple harmonic oscillation?
- 48 In: Yes, a simple harmonic oscillation
- 49 S2: At a moment, I see a mango swinging on the branch over there. It looks like that phenomenon. Now, let's come there to see
- 50 S8: Oh,..., oh..., it is swinging
- 51 S5: But it is so high! Let S1 designate it

- 52 S 1: Look at that. As it is windy, the mango swings. Its motion is something like the mechanical oscillation of the pendulum studied in lecture. Now, let's examine oscillatory terms symbolized for this oscillation
- 53 S 1: The mango is moving to other direction. You see that it is moving back. The position where the mango begins returning is equivalent with the maximum amplitude of the pendulum's oscillation
- 54 S4: Does it oscillate? The mango swings, is it oscillating?
- 55 S 1: Yeah. And the other highest position where it moves back, and begins returning is equivalent with the maximum amplitude of the pendulum's oscillation studied in Math before. This is a real-world phenomenon. It is somewhat different from theory in lecture. However, it just nearly looks like. When the mango is pushed to the other side, for instance ... to this side ... It stands instantly, and then returns to other location. This location is correspond to the maximum amplitude and the maximum angle determined by its stem with the vertical. When it moves back to this direction, we also have the similar values such as maximum amplitude, maximum angle, and so on. And in correspondence to these values, which are smaller than those of ... it means that we conform those values upon some angle ... It means that the horizontal component of its stem is called the amplitude of the oscillation. This angle depends on its location at some instant time considered. And it is termed the phase angle of the oscillation
- 56 S4: How about the equilibrium position?
- 57 S 1: It is at the vertical position when it is not windy
- 58 S4: What? It still oscillates
- 59 S 1: I see ... I said that it oscillates. But in reality, the characters of the oscillation of the mango are dissimilar with those of oscillation in the theory. So I cannot explain exactly. When it is windy, it moves to one side. It does not flicker. We should understand it likely
- 60 In: Now, we can compare the oscillatory motion of the mango with that of simple pendulum. OK! Please go to the computer lab where there is a software from which we can examine oscillatory phenomenon of the pendulum. In addition, we can remember by association with the mechanical simple harmonic motions to explain the electro-magnetic oscillation. OK! Please go to the computer lab
- 61 In: On the screen, we are going to examine the simple harmonic motion of pendulum. Second, we will examine the energy conversation between magnetic field and the electric field in comparison with the mechanical energy included the potential and the dynamic energy. OK! Now, let's observe the simple harmonic motion on the screen. This is Dr. Hensen, Germany author, and Dr. Le phuoc Loc, Dean of our Faculty. Here is a pendulum, right? One terminal of the string is tied to a ball. The other terminal is anchored to some equilibrium point. This is a contracting and expending motion of a star. Its motion depends on the period. It takes several ten thousand years to complete a cycle
- 62 S4: Has this motion ever made it burst?

- 63 In: Well, because our lives is around 100 years, we cannot really know whether it breaks out or not. We just only consider its periodic motion. Now, you see that it is the simple harmonic motion, right? Now, would you show me the relationship between this amplitude with that of the electro-magnetic oscillation?
- 64 S1: Sir, we see that the mechanical simple harmonic motion is a sin oscillation. The distance from here to here is ... the ... the ...the amplitude ... the amplitude of the oscillation. Here, this is the mechanical oscillation. Through observing on its oscillatory state, we can determine clearly its amplitude. For the electro-magnetic oscillation, theoretically speaking, we do not know how they are. However, both of mechanical simple harmonic motion and electric and magnetic motion are the sin oscillation, therefore, we can figure out the relationship between the mechanical oscillation and the electromagnetic oscillation. And the amplitude of the mechanical oscillation at its highest position is equivalent to the ... the ... the electro-magnetic oscillation ... For example, the oscillatory voltage difference signal is equivalent to the maximum voltage difference of the oscillation. And in correspondence with time, we also have the value of the voltage difference  $U$  or  $V$ . As you know, the mechanical oscillation is the one that we can observe easily. But it is difficult to observe the electro-magnetic oscillation. Therefore, basing on the relationship between these two oscillations, we can understand how they are
- 65 In: Now, we examine the next step. As S1 has showed that this is the amplitude, right? We also figure out the amplitude of the following curve. Now, please compare the circular motion with the sin oscillation by remembering by association with the electro-magnetic oscillation in the "oscilloscope" experiment. Now, what would you comment about this mechanical oscillation and its relationship with the electromagnetic oscillation? What would your comment about that? How about its phase? Its initial phase? How about its initial phase?
- 66 S1: Equal to zero
- 67 In: Its amplitude?
- 68 S2: Equal to A
- 69 In: Equal to A. What would you comment? Now, let's remember by association with those that you did on. The "oscilloscope" experiment about the phase, all right! What would you observe on this screen? Here is the sin curve, its phase is equal to zero. For that sin curve, its phase is not equal to zero. Is it correct to what you examine?
- 70 S2: Yeah, exactly
- 71 In: Exactly. You experimented with the "oscilloscope" experiment, didn't you? How many degrees for the initial phase?
- 72 S2: Equal to  $P/2$
- 73 In: Equal to  $P/2$ . Here exhibits two simple harmonic oscillations
- 74 S: Two simple harmonic oscillations with the same amplitudes
- 75 In: Any thing else?

- 76 S: The same phase as well
- 77 In: Any thing else?
- 78 S: The same period
- 79 In: The same period. So how are these two oscillations?
- 80 S: They coincide exactly each other
- 81 In: They coincide each other. What would you comment about these two oscillations?
- 82 S: They are difference in phase
- 83 In: How many?
- 84 S: It is difference in phase ... equivalent to ... the initial phase of the oscillation
- 85 S: Sir, in this case, suppose that we displace it up ... On this circle, the initial velocity of this moving point is equal to zero. When we displace the second oscillatory curve to here, you see that the uniform circular motion of the yellow point is equivalent to the difference in phase with  $\hat{i}$ . Therefore, we can indicate the difference in phase of the blue curve, and that of the yellow one ...
- 86 In: How many degrees?
- 87 S: This  $\hat{i}$  is equal to  $P/4$
- 88 In: Well, equal to  $P/4$ . What would you observe about these two simple harmonic motions?
- 89 S: They are difference in phase. Their difference in phase angle is  $P/2$
- 90 In:  $P/2$
- 91 S: The initial location of the blue one is correspondent to ... equivalent to its vertical component on the Y axis, that is the amplitude. So is the yellow one. Therefore, the curve of the simple harmonic motion is exactly the vertical components of the circular motion on the Y axis. We see that the yellow one and the blue one are difference in phase. The difference in phase angle is  $P/2$
- 92 In: Now, let's come to another section. What would you comment about these two simple harmonic motions?
- 93 S: Difference in phase
- 94 S: Same frequency
- 95 S: Same frequency as well
- 96 In: OK! What would you observe about the superposition of these two simple harmonic motions?

- 97 S: They are the same phase and the same frequency, but different amplitudes. And this white curve is the superposition one of two above simple harmonic oscillations. They are the same phase and the same frequency. And the amplitude of the superposition curve is equal to  $(A_1 + A_2)$
- 98 In: What would you comment about these two sin oscillations? S3, would you have some opinions? Comment, please! S4?
- 99 S4: I see that the white curve is the superposition oscillation of the two ones. The initial phase of the oscillation of the yellow curve is equal to zero. And the blue one is difference in phase with the yellow one. Therefore, the superposition of two oscillations ... I see that its phase is different, and its amplitude is still equal to A, equal to  $(A_1 + A_2)$ . That is my opinions
- 100 S1: No, because these two oscillations are difference in phase, the amplitude of the superposition is not equal to  $(A_1 + A_2)$  any more. It equals to  $2A \cos 60$
- 101 S2: I would like to have more opinions about these two oscillations ... two oscillations ... According to the yellow curve, they are the same frequency. The white curve, the superposition curve, also has the same frequency. Let's observe on this curve. We have 1, 2, 3 ... 4.5 small boxes in correspondence with the horizontal components of the white curve. You see that it also is the same frequency with those two oscillations
- 102 In: Let's observe on here. You see that these are two oscillations. They are difference in phase. Their difference in phase angle is 160 degrees. What would you comment about this angle? The yellow curve determines the  $X_2$  oscillation, right? And the blue one determines the  $X_1$  oscillation. And these two oscillations are difference in phase, 160 degrees, right? Here is 185 degrees. What would you observe about the superposition curve?
- 103 S2: Its amplitude is small
- 104 In: Yeah, it is small. So in case of 180 degrees, what is going on?
- 105 S2: They coincide with the X axis
- 106 S2: And the superposition of the amplitude is equal to zero because  $\cos(P/2)$  is equal to zero
- 107 In: These are curves of three simple harmonic motions. Would you show applications in reality?
- 108 S4: To me, they are three simple harmonic motions. Their difference in phase angle is 120 degrees. They look like the oscillatory currents of three phase lines. In reality, they are the oscillatory currents of the three phase lines
- 109 In: Now, would you let me know what this oscillation is? Is it damped oscillation?
- 110 S2: Yeah, sir
- 111 In: Now, would you relate to some examples in reality? Some damped phenomenon occurring in reality?



- 112 S1: In reality, this damped oscillation is ... There are many damped oscillation appearing in reality. We study about the ideal oscillations in lecture, but in reality, most of them are damped oscillations. For example, the oscillation of the pendulum in the air is a damped oscillation. For another examples, some oscillations, generally speaking, if any oscillatory motions are acted by frictional forces, its amplitude decreases with time. Finally, it slowly stops oscillating
- 113 In: Now, let's come to another section of this program. OK! This is oscillatory circuit and the energy conversion between the electrical energy and the magnetic energy. Dr. Hensen, Germany professor, and Dr. Le phuoc Loc, Dean of our faculty, co-operated to program this software. Now, please observe and explain it. Basing on this phenomenon, would you please compare some mechanical oscillatory quantities with the electro-magnetic quantities? Please explain this case
- 114 S1: Suppose that the capacitor is charged at the initial time, and it stores some energy called electric energy. This energy is correspondent with the potential energy in the mechanical oscillation, and correspondent with this time ... For example, at the another time, the capacitor discharges, and the electric energy converts slowly to magnetic energy
- 115 S4: For this oscillation, the charges distributed on two plates are equivalent to the amplitude of the mechanical oscillatory motion. And the instant current ( $dq/dt$ ) is equivalent to the velocity ( $dx/dt$ ) of the mechanical oscillatory motion
- 116 In: How about the electric energy?
- 117 S1: It is equivalent to potential energy
- 118 In: How about the magnetic energy?
- 119 S1 and S3: It is equivalent to the dynamic energy
- 120 In: Would you explain the conversion between the electric energy and the magnetic energy in forming the sin wave?
- 121 S1: First, at the time ( $t = 0$ ), the electric energy is maximum, and the magnetic energy is zero. The electric energy then begins converting to the magnetic energy. Second, at the time ( $t = T/4$ ), that is it is equal to  $1/4$  periods, the electric energy is zero, and the magnetic energy is maximum. And then, the magnetic energy converts continually to the electric energy. Third, at the time ( $t = T/2$ ), that is  $T$  is equal to  $1/2$  periods, the magnetic energy is zero, and the electric energy is maximum. And the process of conversion has repeated periodically. Finally, after the time ( $t = T/2$ ), the electric energy converts to the magnetic energy
- 122 S2: I have some opinions, sir. It is clear that this is a sin oscillation. We see that the number of charges disappearing from the plate of the capacitor is equal to the number of the magnetic field lines appearing in the solenoid
- 123 In: I appreciate very much for your participating this interview today. Last week I gave you sample surveys. Please fill them in, and give opinions about this teaching approach, learning, as well as toward science. Please drop them in the mail box of our faculty. And you may contact directly with me whenever if it is possible. Again, I appreciate your co-operation for the interview today.

## STUDENTS' RESPONSES ON THE SURVEY

Item	1 and 2	P	3	P	4 and 5	P
1	15	88.23%	2	11.76%	0	0%
2	7	41.17%	3	17.64%	7	41.17%
3	13	76.47%	4	23.52%	0	0%
4	12	70.58%	3	17.64%	2	11.76%
5	15	88.23%	2	11.76%	0	0%
6	14	82.35%	3	17.64%	0	0%
7	15	88.23%	1	5.88%	1	5.88%
8	17	100%	0	0%	0	0%
9	14	82.35%	3	17.64%	0	0%
10	17	100%	0	0%	0	0%
11	2	11.76%	3	17.64%	12	70.58%
12	6	35.29%	4	23.52%	7	41.17%
13	17	100%	0	0%	0	0%
14	10	58.82%	7	41.17%	0	0%

---

1= Strongly agree  
 2= Moderately agree  
 3= No idea  
 4= Moderately disagree  
 5= Strongly disagree  
 P: Percentage (N=17)

## Appendix IV

"Wheatstone Bridge" experiment - April 20, 1996 - 1:00 - 4:00 pm

( $T_o = T_o$ ,  $T_i = T_i$ ,  $N_g = N_g$ , and  $T_h = T_h$  [Students])

Students worked with others on five problems posed in the experimental instructions:

1. Establish Ohm's law.
2. Explain a problematic phenomenon from an experiment with two different unknown light bulbs in parallel.
3. Explain a phenomenon from an experiment with the same two light bulbs in parallel.
4. Indicate the difference between two unknown resistors in a complicated circuit with two same light bulbs.
5. Use the "Wheatstone Bridge" apparatus to measure the resistances of the two above resistors in such a way as to test the result from the fourth question.

### Laboratory instructions

#### The Wheatstone Bridge experiment

##### Purpose

The purpose of this experiment is (1) establishing Ohm's law, (2) testing whether Schön's conceptualization of reflection-in-action is applicable and appropriate in the authentic teaching laboratory, (3) using the Wheatstone Bridge to measure the resistances as a way to check the conclusions in the third question, (4) and measuring these resistors in parallel and series.

**Procedure:**

1. Establishing the circuit as the following figure:

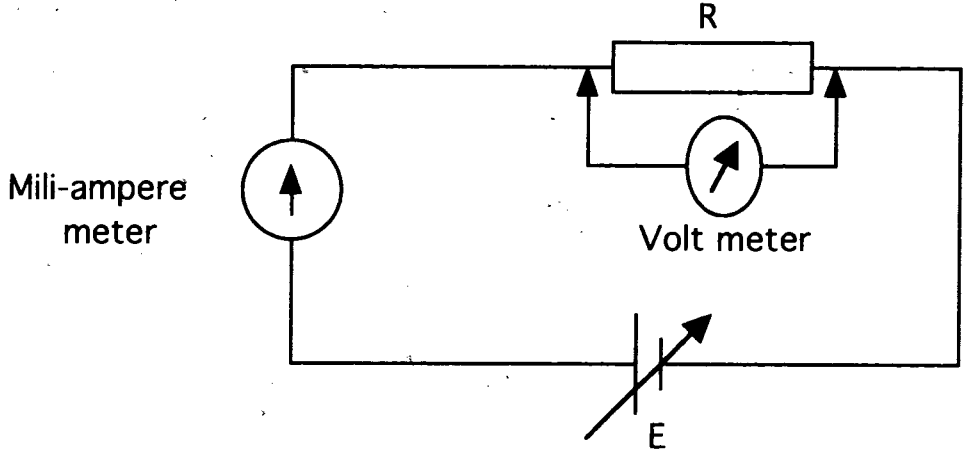

Vary the voltage difference of the power supply according to the following ranges:  $E_1 = 3V$ ,  $E_2 = 5V$ ,  $E_3 = 6V$ , and  $E_4 = 7.5V$ , and then take four different readings on the voltmeter and milli-ampere meter, and place them in the table below:

U	I	U/I

Give the conclusion about the ratio of  $(U/I)$ , and then derive Ohm's law.

2. a. Establish the following circuit as figure (a):

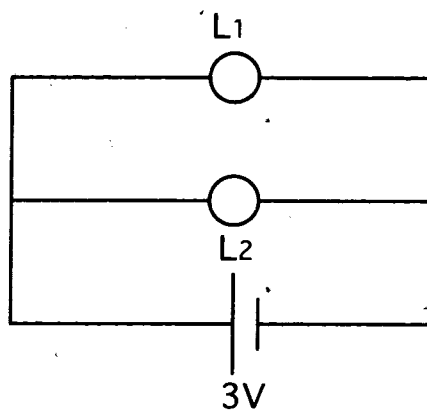

According to the brightness of two bulbs, analyze and explain:

- Why one bulb is dim and the other is bright
- Electrical characteristics of two bulbs
- Applications of two bulbs in reality.

b. Establish the circuit as the figure (b)

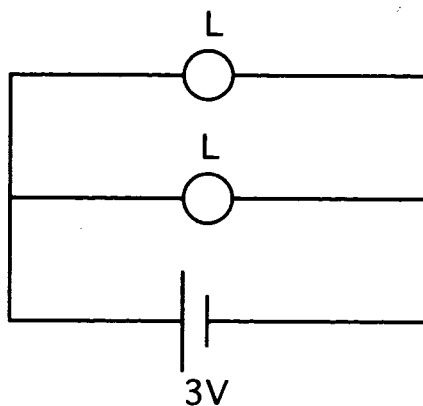

Give comments about the brightness of two bulbs in the circuit (b), and then compare the electrical characteristics of two bulbs.

c. Establish the circuit as the figure (c)

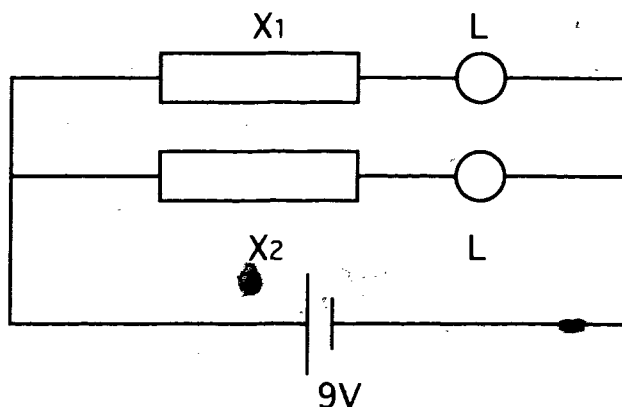

According to the brightness of two bulbs, reason and conclude about the different values of two resistors.

3. a. Use the Wheastone Bridge to measure the resistances of X1 and X2, and place them in the following table:

$R_0$	I	I'	X

b. Compare these results measured with the conclusions derived from the second question 2c.

c. Measure X' and X''. It is noting that X' is the equivalent value of X1 and X2 in series, and that X'' is the equivalent of X1 and X2 in parallel. Place the data gathered in the table below:

$R_0$	I	I'	X'

$R_0$	I	I'	X''

d. Indicate the possible errors of  $X_1$ ,  $X_2$ ,  $X'$ , and  $X''$ , and write the results.

### Principles of the Wheatstone Bridge:

The Wheatstone Bridge is useful for measuring very small changes in resistance. The figure below shows the physical connections and the schematic for a Wheatstone Bridge:

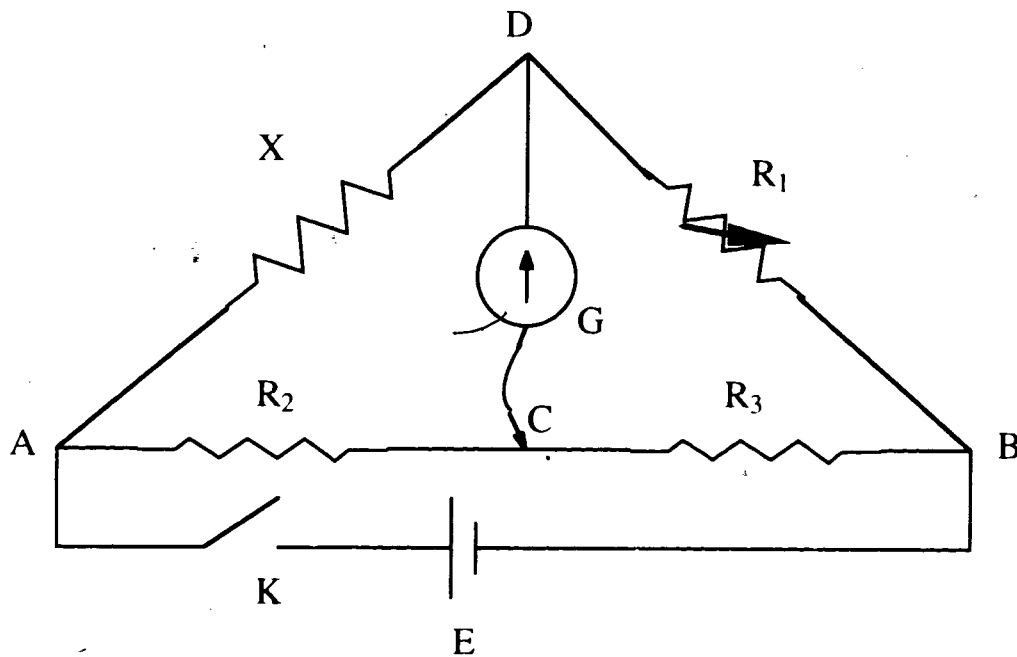

$R_1$ ,  $R_2$  and  $R_3$  are the variable resistances, and  $X$  is unknown resistor.

Close the switch  $K$  and adjust  $R_1$ ,  $R_2$ , and  $R_3$  in order to have 0 - reading on the galvanometer. It is, at this point, to say that the Bridge is balanced ( $V_c = V_d$ ), and we have:

$$X = R_1(R_2/R_3)$$

If we replace the circuit  $ADB$  in series by a copper wire, the Wheatstone Bridge becomes the electrical wire Bridge as the figure below:

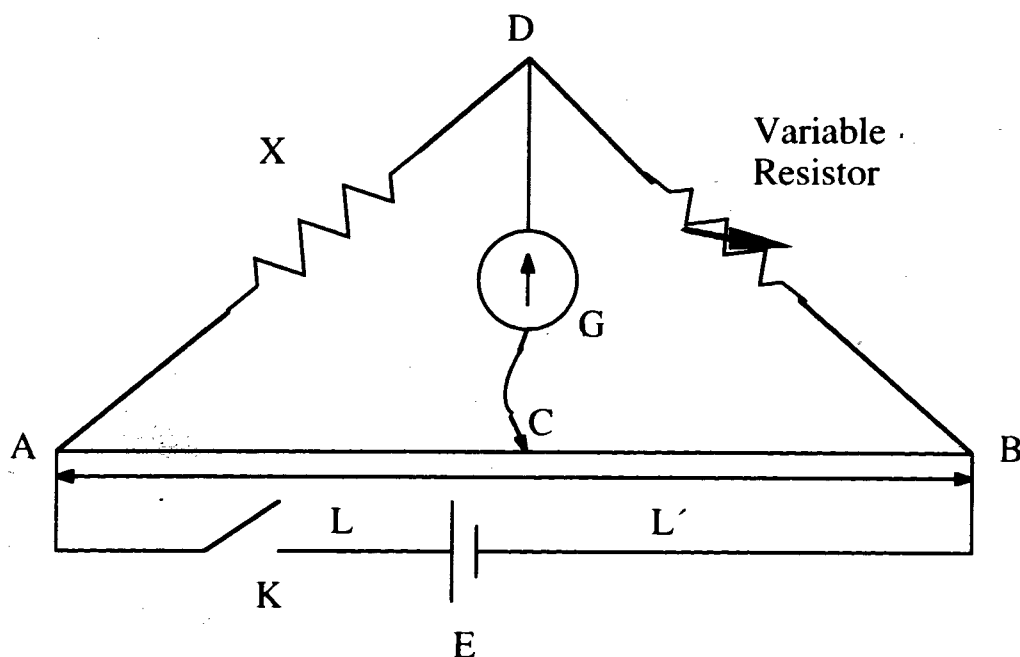

Move the alligator clip along the wire to find a point at which we have the zero-reading on the galvanometer. It is said that the Wheatstone Bridge is balanced, and we have:

$$X = R_0(l/l')$$

### Materials

One digital multimeter; one multimeter; one galvanometer; one regular power supply; one resistor box; two different bulbs with the unknown rated voltage; two same bulbs; resistors; one electrical circuit with a copper wire and a stick meter; connect wires.

### Additional questions:

1. Do you think that the resistance of the bulb obeys Ohm's law? Explain why?
2. What do you think about the relationship between the brightness of two bulbs and the power delivered by the electrical source?
3. When the Wheatstone Bridge is balanced, indicate:  $X = R_1(R_2/R_3)$
4. Indicate  $X^3 = X_1 + X_2$  and  $X^4 = X_1 // X_2 = (X_1 \cdot X_2) / (X_1 + X_2)$ . Compare these with the empirical results, and give the conclusions.
5. Why is it better to take  $l = l'$  for the measurement?



## Transcript and analytical comments

Students were instructed to work in groups of four, which were taped by video-tape technicians. Students' dialogue about solving five problems appears in the left-hand column. Analytical comments appear in the right-hand column, with diagrams of apparatus.

<u>Students' discussion</u>	<u>Analytical comments</u>
1 To: Before practicing, let's check electrical ... instruments of this experiment. A power supply. A galvanometer. An electrical wire strained on the two terminals of a stick-meter. A contact switch K, a resistor box R. Some unknown resistors. Two 3 V DC bulbs. Two unknown rated voltage bulbs. One VOM and one digital multi-meter. Now, let's set up the circuit on the figure ... the figure one. Ti, set up the circuit please	In this experiment, students follow the procedures of the lab instruction to establish Ohm's law. As presented in Chapter Two and seen here, the traditional laboratory is exercises with a primary focus on the verification of established laws and principles.
2 Ti: Where is the ampere meter?... Connect to its terminals, please. The ampere-meter. Let's connect two terminals to ... the ampere meter. And the power supply ...	
3 Ng: The power supply... All right! But the power ...	
4 To: One terminal of the ampere- meter is connected in series with the resistor R	
5 Ti: This resistor? Is this a resistor?	
6 Th: Yeah, that's right	
7 Ti: How about that terminal?	
8 Th: ...	
9 Ti: Let's check the circuit to see whether it is correct or not. Should we ask the teacher?	
10 Ng: I think this is a simple circuit. We do it all at once. OK! Already!	
11 To: Teacher, please check our circuit, sir	

- 12 Ti: Check this circuit, please. I think we set it up correctly. Is this a resistor, sir?
- 13 In: Yeah, it is. Please notice that you should set this upon to its current scale. If the current which flows through it is small, you change it into milli-ampere scale. And if the current through it is high, for example, 20 A, you should change it to the ampere scale here
- 14 Ti: 20 A! OK! Turn on the power supply, please
- 15 Ng: Measure the value of the resistor. Vary the voltage of the power supply from 3 V to 7.5 V. And by the way, we take the data
- 16 Ti: How many volts?
- 17 Ng: 3 V
- 18 Ti: 3V ... 3V, Ng!
- 19 To: Read ... read the voltage difference on there right?
- 20 Ti: ✓ Yeah, on here ... More, please observe whether the voltage is correct or not
- 21 Th: ... Not yet ... Not yet ... Little bit more, downward ... OK! OK! It is all right
- 23 Th: ... Little bit more, Upward ... upward ... OK! It is all right
- 24 Ti: All right! OK, 3 V, 0.26
- 25 Th: It's coming up to 5V
- 26 Ti: ... Increase to 5 V. Here is 0.4
- 27 Th: It is over ... 0.42
- 28 Ti: 0.43
- 29 Ti: 6 V, OK! 5.2. Turn it off, OK!
- 30 Th: ... 3.5 ...
- 31 Ti: 5.2. This one is 0.52. How come do we read that it is 5.2?

While conducting experiment to establish Ohm's law, students use components of the scientific method. They identify two variables : the current flowing through the resistor and the voltage difference inserting on two terminals of the resistor. From utterance 14 to utterance 40, students manipulate the following scientific skills: observing, measuring, recording and collecting the data and so on.

- 32 Th: This value is wrong reading!
- 33 Ti: 2, 2.6
- 34 Th & Ti: 2, 2.6, 4.3, 5.2, right?
- 29 Ti: 6 V, OK! 5.2. Turn it off, OK!
- 30 Th: ... 3.5 ...
- 31 Ti: 5.2. This one is 0.52. How come do we read that it is 5.2?
- 32 Th: This value is wrong reading!
- 33 Ti: 2, 2.6
- 34 Th & Ti: 2, 2.6, 4.3, 5.2, right?
- 35 Th: Yeah
- 36 Ti: 6 V right?
- 37 Th: Yeah
- 38 Ti: 5 ... and Th: 5.2. Adjust it!
- 39 Ti: 7 V. Upward, upward, more, more, up! Stop. Downward a little more, 5.9. How? We take one decimal in calculation, OK?
- 40 Ng: Wow, the value of the resistor is just 1 ... ohm, isn't it?
- 41 Ti: 3V and 5.6 mA. How about the ratio of (U/I)?
- 42 To: 1.15
- 43 Ti: 1.1, OK?
- 44 To & Ng: Yeah, 5V
- 45 To: ... and the current through it is 4.3 mA
- 46 Ti: How many? How about the ratio?
- 47 To: 1 ... 1.16.
- 48 Ti: 1 ... ?
- 49 Th: 1.6

Students use skill of interpreting the data and skill of reasoning to define the problem.

- 50 Ng: No, 1.11
- 51 Ng: 1.15, 1.16
- 52 Ti: 1.16, all right!
- 53 Th: Yeah
- 54 Th: 1.6
- 55 Ng: 1.15, 1.16
- 56 To: 6 V and 5.2 mA
- 57 Ti: All right!
- 58 To: 1.1
- 59 To: 7 V, 5.9 mA
- 60 Ti: How many? 5.9
- 61 To: 1.1
- 62 Ti: Exactly, right? Do exact division, OK!
- 63 Ng: Yeah, exactly, all right!
- 64 Ti: 1.1, OK! Therefore, after measuring four times, we see if  $U$  increases, the  $I$  does too. And the ratio of  $(U/I)$  equals to 1.1. How about our conclusion?
- 65 Th: It means that the ratio of the voltage difference and the current is a constant
- 66 Ti: On this circuit ...
- 67 Th: Yeah
- 68 Ti: It is a constant. So what is the expression of the Ohm's law? The Ohm's law? All right!
- 68 Ti: It is a constant. So what is the expression of the Ohm's law? The Ohm's law? All right!
- 69 Ng: The Ohm's law expresses that the ratio between the voltage difference and the current is a constant

- 70 Ti: ... is an unchanged term ...
- 71 Ng: ... a constant, and that constant is equal to the ratio of  $\{(U/I) = R\}$ . It is the resistance, the resistance of the circuit ... Therefore, the voltage difference on two terminals of the circuit ... the ratio of the voltage difference on two terminals and the current flowing through it is a constant. It exactly is the resistance  $R$ . So we find out that the resistance of this circuit is a constant
- 72 Ti: OK! Let's conclude ...
- 73 Ng: We can measure. Ah, we can measure ... the resistance
- 74 Ti: OK! Let's conclude ...  $\{(U/I) = R\}$ . It corresponds to what we study on the lecture course
- 75 Ti: Now, follow the lab instruction to do the second circuit, right? Read the instruction for the second circuit, please
- 76 Th: Set up three circuits of the figure ... A ...
- 77 Ti: First, let's do the circuit A ...
- 78 Th: In A's, the current flowing through two different bulbs ...
- 79 Ti: Where are two bulbs?
- 80 Ti: There are two different bulbs. Already! Turn on the power supply to measure, please. How many?
- 81 Th: Now, the output voltage of the power supply is 3V right?
- 82 Ti: 3 V, 3V, really?
- 83 Th: 3 V
- 84 Ti: 3 V, right?

In traditional laboratory, students manipulate scientific skills for testing the authenticity of what they have been told in lectures, a form of re-memorization.

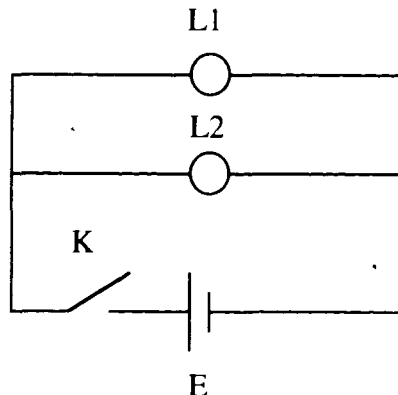

Through experimenting, students frame the research questions, and make up problems on their own interest. In the course of reframing activities, students are quite free to design experiments to search for genuine science and to develop practical knowledge.

- 85 Ti: Adjust to 3 V, OK? Twist it. Twist tightly ... Do not be afraid
- 86 Th: Vary to increase the output voltage a little more. It's up
- 87 Ti: Already!
- 88 Th: ... It's correct
- 89 Ti: Twist, twist it please. That is ... Now, with two different bulbs, we set up the circuit with two different bulbs. We consider those are  $L_b$  and  $L_d$ , OK!
- 90 To: Notice that their symbols are  $L_b$  and  $L_d$
- 91 Ng: The power we consider ...
- 92 Ti: This is 3 V, right?
- 93 Th: 3 V
- 94 Ti: 3 V. Now,  $L_b$  is the bright bulb, OK?
- 95 Ng: OK! According to that consideration to do ... do that ...
- 96 Th:  $L_d$  is dim bulb. It glows at proper brightness
- 97 Ti: Yeah,  $L_d$  is dim bulb
- 98 Ng:  $L_b$  is the bright bulb
- 99 Ti: Already? Now, the output voltage of the power supply is 3 V. It is unchanged. Now, how do we consider about these two bulbs?
- 100 Th: To me, this bulb is ... Its current ...
- 101 Ti: We observe that their brightness is different, right?
- 102 Th: It means that we have to ...
- 103 Ti: ... Why are they different?

Significantly, surprising events arose from the inquiry activity help students shape their understandings about the phenomenon, and lead to another reframing activity to construct new meanings of science concepts.

The reflective learning cycle includes three phase: problem setting, reframing problems, and the resolve.

Problem setting:

Students' dialogue in this phase reveals that the scientific method cannot work for in the case of real-world phenomenon because scientific skills such as "observing," "identifying variables," or "hypothesizing," and so on bear much meaning in the absence of due consideration of the context of inquiry, or the particular problem which drives the scientific investigation.

- 104 Th: Because there are different currents flowing through them, the currents flowing through them are
- 105 Th: ... Two bulbs are different ...
- 106 Ti: Do you know which one is higher and which one is lower?
- 107 Th: To me, the bulb is bright, because the current splits to it more than ... that of the dim one. The current is higher
- 108 Ti: Do you agree? The current through ... We question that ... Let's consider the intensity of the current
- 109 To: Now, it is not sure either to explain it based on the current ...
- 110 Ti: ... base on the current ...
- 111 To: We base on their bright level and dim level, basing on their electrical characteristics to explain why they are bright or dim?
- 112 Ti: Now, Th's suspicion is that the currents flowing through two bulbs are different. Now, how do we feel about which one has the high current?
- 113 To: Which one has the higher current?
- 114 Th: To me, the bright one is higher
- 115 Ti: All right, our comment is that:  $I_b > I_d$ , exactly? This is just the comment. Our comment is that:  $I_b > I_d$ , How about  $N_g$ ?
- 116 Ng: To me, the bright level of the bulb is not affected by the output voltage. It is affected by the intensity of the current. But, in one hand, it is not enough ... It involves its resistance and power
- 117 Ti: The power, its rated power, right?
- Students make up their own explanation for the phenomenon in utterance 103, and formulate the hypothesis in terms of current.
- Student observes and explains why one light bulb is dim and other is bright.
- Student formulates the hypotheses in terms of current, power, and the resistance. Ng refutes the idea of voltage difference because the out put voltage offers to the parallel circuit is the same.

- 118 Ng: In this case, I do not mention the voltage difference because the voltage that the power supply offers to it is 3 V. So its ... power also affects the bright and dim level
- 119 Ti: The ... power ... its rated power, right?
- 120 Ng: ... and its resistance ...
- 121 Ti: And To, what do you think about that?
- 122 To: Now, Th's opinion is to base on the brightness and the dimness of the bulbs. That means to base on the intensity of the current
- 123 Ti: ... just judge so, just judge so ...
- 124 To: But how do we base on the intensity of the current to explain it?
- 125 Ti: OK! I think that at first, the bulb is bright because its filament burns up, right? The more it burns, the brighter it is, and the more luminous it is as well. We see, if the current which is flowing through it is higher, it is brighter. Because the current flows through it a lot, it creates more heat fiction. Therefore, it is more luminous. So, I agree with Th's opinion
- 126 Ng: It also emits heat, all right!
- 127 Ti: It is just the judgment only. It means that we want ... want to test whether our judgment is wrong or right. Now, we measure them. Separate them to measure, OK! Let's take it out to measure, OK? Separate the circuit. Take the  $R_b$  out, take the  $R_b$  out ... right?
- 128 Ti: Connect that milli-ampere meter to the power supply having 3 V, 3 V. And then, turn off the power supply ... Take the  $L_b$  out
- 129 Ng: Measure  $L_b$
- 130 Ti: Take  $L_b$  out, right? We take the  $L_b$  out, because we test  $L_b$ , right?
- Student refute the hypothesis of the output voltage.
- Hypothesis of resistance.
- To challenges Th's opinion.
- Students try to apply knowledge learned to explain the phenomenon.
- Finally, students have to conclude that the phenomenon is problematic, and frame the problem by "seeing" it in a new way.
- Reframing activity 1
- They conduct a hypothesis-testing experiment to test their hypothesis.



- 131 Th: All right! ... It connects to the milli-ampere meter
- 132 Ti: This terminal ... Now, it connects with the milli-ampere meter. Therefore, it is ... This terminal ... It connects to the milli-ampere meter, so ...
- 133 Th: ... is connected to the milli-ampere meter
- 134 Ti: Connect the plus terminal to the milli-ampere meter, the plus ... Connect the minus terminal to ... plus terminal to the milli-ampere meter
- 135 Ng: The minus terminal to the circuit, right?
- 136 Ti: That is all right, the minus one is connected to the circuit ... Turn it off, yet? ... That ... insert that on the circuit, right?
- 137 Ng: What the disorder is being connected under the ...?
- 138 Ti: Here, right?
- 139 Ng: Other side, over there ...
- 140 Ti: Here, right?
- 141 Ng: Yeah ...
- 142 Ti: OK! Here ...
- 143 Ng: Displace it to connect here ...
- 144 Th: No, it is not necessary to displace. Connect through ... right?
- 145 Ng: Here, it faces here, right?
- 146 Ti: Because two bulbs are in parallel, just connect one. We just use only one branch of the circuit ...
- 147 Ti: Now, the output of the power supply is connected to the milli-ampere meter, just 3V here. Take it to put here. Do you put it at the right position yet?

- 148 Ti: Is it right?. No, it is at the wrong position ...
- 149 Ng: Over that position of reading scale, all right!
- 150 Ti: OK!
- 151 Ng: Here is exactly correct
- 152 Ti: How many mAs are you observing on the reading scale? Is it correct? Exactly, it is 0.26 mA. OK! Turn off ... Where is the dim bulb? Where is the dim bulb? The  $I_d$  ...
- 153 Th: Turn on
- 154 Ti: Turn it on ... It is ... 0.32 .
- 155 Th: So we cannot conclude about the current
- 156 Ti: So, our conclusion is wrong. Recently, Th has said that  $I_b > I_d$ . Now, in the reality,  $I_d > I_b$ , right? Now, I think it involves the resistance. How about the Ohm's law in this case?
- 157 Th:  $R = (U/I)$
- 158 Ti: We recognize that  $U/I = R$ , right? The output voltage which the power supply offers to them is the same, right? So  $U$  is ... Therefore,  $U = RI$ , or  $U_b = I_b R_b$ , and  $U_d = R_d I_d$ . But these two voltages are equal to each other because the output voltage of the power supply offered to them is the same. Hence,  $I_b = (U_b/R_b)$ ;  $I_d = (U_d/R_d)$ . And therefore,  $(I_b/I_d) = (R_d/R_b)$ . But we have concluded the above ratio already, all right!  $I_d > I_b$
- 159 Ng: Therefore, we have: that ratio is less than 1. It is less than 1
- 160 Ti: Hence, this ratio is less than 1, right? Its denominator is greater. So it is less than 1, right?
- 161 Ng: ... less than 1. Therefore,  $R_d < R_b$
- 162 Ti: Hence,  $R_d < R_b$

Students test the bright bulb and then look for the dim bulb for the next test

The result opposes their expectation. As presented in Chapter Four, theory is

used in the process of reflection-in-action, but is neither the starting point nor the product of reflection. Rather, the starting point of reflection is practical knowledge applied in particularly practical case.

Accordingly, students move to another reframing activity to search for new understandings about the phenomenon.

#### Reframing activity 2

Students conduct a move-testing experiment for the explanation of the difference of two resistances.

They find out that  $R_d < R_b$ .

163 Ti: The second conclusion is that  $I_a > I_b$

164 Ng: The resistance of the dim bulb,  $R_d$  ...

165 Ti: ...  $< R_b$

166 Ti: Now, is it related with the power? Its consumed power, the consumed power

167 Th: The consumed power of the bulb

168 Ti: ... right?

169 Th: Yeah ...

170 Ti: Now, we have  $P = UI = (U^2/R)$ , right? So now, we have  $U_b^2 = P_b R_b$ , and  $U_d^2 = P_d R_d$  ... Hence, these voltages are equal to each other, right? They are equal. Therefore, we have:  $P_b R_b = P_d R_d$ , right?

171 Ng: Here is the paper. Here is the paper ...

172 Ti: ... Now, we are establishing the ratio:  $(P_b/P_d) = (R_d/R_b)$ , right? And we have ... But this conclusion is  $R_d < R_b$ , the numerator is less than the denominator

173 Th: ... the numerator is less than the denominator ...

174 Ng: ... the numerator is less than the denominator. So its ratio is less than 1

175 Ti: ... less than 1, right? ... Less than 1 ... less than 1. Because we have the ratio of  $(P_b/P_d)$  is less than 1. Therefore, we have:  $P_b < P_d$ . So, according to Ohm's law, we derive that the consumed power of the bright bulb is less than that of the dim bulb, that is  $P_b < P_d$ . Coming here already!

176 Ng: This is the consumed power, right?

177 Th: Yeah, the consumed power, exactly. We are considering the consumed power. It equals to  $(U^2/R)$

Students conduct another move-testing experiment to indicate the difference of two consumed powers.

Here, it is worth pointing out the importance of mathematics in both forms --data and reasoning-- to seek solutions of the problem.

They construct a new understanding of the phenomenon based on the ratio of  $P_b < P_d$ . They then move to the third reframing activity to search for new meanings of science concepts related to the phenomenon.

178 Ti: OK! Each bulb looks like human being, it has a power. This power characterizes for a current flowing through it and the voltage difference on it. It means that it involves the power

### Reframing activity 3

Students construct a new meaning of the science concept, the rated power.

179 Th: The rated power, it is all right!

180 Ti: ... The rated power

181 Th: Yeah, it's right

182 Ti: What is the rated power? Is it the consumed power? When we increase the consumed power until the bulb glows at normal brightness, right? In this case, that power is called the rated power, OK? But each bulb ...

Again, students construct another new meaning for the concept of the power, the rated power.

183 Th: ... If the brightness of two bulbs involves the ... the rated power, they have to involve the rated voltage

### Reframing activity 4

184 Ti: The rated voltage as well

185 Th: Yeah, all right! According to this argument, how can we conclude which one has the higher rated voltage ?

Student makes up the problem.

186 Ng: Not yet ...

187 Ti: ... but I question like that, consider now ...

188 Ng: Yeah ... if so ... because the output voltage offered by the power supply, recently, in each case is 3 V. We see that the bulb ... The bright bulb ... and... the dim one were supplied by the same voltage. But seeing clearly that their brightness is different, right? So, it is clear to say that the rated voltage of the bright bulb is different with the dim one ...

189 Ti: What do you have to say about why they are different? How do you prove that the brightness depends on these two rated voltages?

Ti repeats Th's question for framing the problem.

190 Ng: If the rated voltage of the bright bulb is less than that of the dim bulb

191 Ng:  $U_b < U_d$

192 Ti: The rated voltage, all right?

193 Ti: Yeah, the rated ... finding ... Now, how do we indicate them?

194 To: Now, we found the difference between two rated voltages already. It's all right. Now, in order to make sure that it is correct, we have to test them. By the mean ... Now, one bulb is bright, and other is dim, right? This one is dim. Now, let's increase the voltage in order to make it brighter

Students discuss about the way to indicate the rated voltages of two bulbs.

195 Ti: ... It means that we increase the voltage so that ...

196 To: Yeah ... So that the bulb glows at normal brightness according to the required rating of the manufacturer, that is the rated voltage

197 Ti: OK! Now, let's split the circuit ...

198 To: Increase at the same time. Increase their voltages so that the dim bulb glows at a little bit more brightness, and the bright bulb glows at little bit more normal brightness

199 Ng: To me, I think

200 Th: All right!

201 Ng: ... that it is not necessary to increase because the voltage of each branch is the same, OK? In this case, they are offered with the same applied voltage. For example, if it is 3 V, each branch gets 3V. And if 4 V, each branch gets 4 V

The discussion leads to an argument about the way to indicate the rated voltage of two bulbs.

202 To: Right, while increasing the output voltage of the power supply, the consumed powers of bulbs increase. But their brightness is different, right?

- 203 Ng: Yeah, it is different. I agree with To's opinion that if we increase so that the bulb glows at normal brightness according to the rating of the manufacturer marked on the bulb. If not at that time ...
- 204 Ti: Let's try in order to see what is going on?
- 205 Ng: I worry a little bit that the small bulb will burn out
- 206 Ti: The voltage applied to the two bulbs increases at the same time, this one will be brighter than that one
- 207 Ng: It is brighter, all right!
- 208 Ti: Now, we separate hem to experiment
- 209 Ng: OK! why not?
- 210 Ti: Now, we separate them to test, OK?
- 211 Ng: It means that we measure the voltage difference between two terminals of each bulb, right?
- 212 Ti: Yeah! yeah, right ... We vary the output voltage so that the bulb glows at normal brightness
- 213 Ng: It is enough. It means that we measure that makes the bulb glow at normal brightness. Ah ... uh, all right, OK ... OK, at normal brightness according to the rating of the manufacturer
- 214 Ti: ... so that the bulb is white bright. It is all right!
- 215 Ng: ... in order to test how does the voltage change?
- 216 Ti: Now, first, let's measure the voltage, the rated voltage of the bulb ...
- 217 Ng: The dim bulb?

Students' argument leads to an exploratory experiment to see what follows without expectation as testing To's suggestion. The result observed from this experiment opposes To's suggestion. Accordingly, students move to the fifth experiment to seek new understandings about the phenomenon, and new procedures to solve the problem.

#### Reframing activity 5:

From utterance 210 to utterance 218, students develop practical knowledge for designing two move-testing experiments to indicate two rated voltages.

- 218 Ti: Yeah, the dim bulb. How many volts do you measure the rated ... voltage of the dim bulb? Now, how many volts do we increase? Slowly, slowly ... Let's vary to 5V. Now, take ...
- 219 Th: Now, take the power supply, take the power supply
- 220 Ti: Let's vary from 2 V, OK! Now, vary U from 2 V, 3 V, 4 V, 5V, 6 V, right? Now, begin taking at 2 V
- 221 Ng: 2 V ... It's ... What?
- 222 Th: No, this scale is used for ampere rating
- 223 Ti: We increase slowly so that we can get the value as well, right?
- 224 Ng: Now, we take the data all at once
- 225 Ti: We increase the voltage until we see that it glows at normal voltage
- 226 Ng: Well, we just only observe the brightness
- 227 Th: We just turn on instantly the power supply to try it. Check again please
- 228 Ti: OK! It is around 2 V, 2 V
- 229 Th: OK! 2 V
- 230 Ti: 2 V, 2 V
- 231 Ng: We will measure the one that glows at normal brightness. It is illuminated at 2 V already!
- 232 Th: Too low. It glows at very proper brightness. Let's increase more ...
- 233 To: We increase. And the corresponded voltage is the one that we need ...
- 234 Ti: If we increase, and this ... it is tenth scale, right?
- 235 Th: Yeah
- They design a first move-testing experiment.

- 236 Ti: ... do you see it glows at normal brightness?
- 237 Th: Not yet. Vary a little bit more ...
- 238 Ng: We can increase more ...
- 239 To: Now, let's insert this into the VOM to measure all at once. And increase the voltage at the same time with that one
- 240 Ti: Increase ...
- 241 Ng: We have to measure it although we know already. We can predict the rated voltage of the bulb
- 242 Th: We test the brightness of the bulb. We do not test the resistance
- 243 Ti: ... more ... I see that this bulb glows at less brightness, right?
- 244 Th: ... more
- 245 Ti: All right?
- 246 Th: Not yet
- 247 Ti: More ... more
- 248 To: We vary the voltage while reading
- 249 Ti: All right? Is it at normal brightness?
- 250 Th: Let it glow at some little more brightness ...
- 251 Ti: OK?
- 252 Th: OK! Nearly 6 V
- 253 To: Let's suppose that it is ... 6 V
- 254 Th: OK! 6 V
- 255 Ti: Does this one glow at the normal brightness?
- 256 Ng: OK! Lightening like that is fine. White brightness

They conclude the rated voltage of the dim bulb is 6 V.



- 257 Ti: I see it glows at white brightness. It operates normally with normal brightness indicated. Its ... rated voltage is 6 V. We choose it temporarily, OK? Now, we can say that its rated voltage is 6 V. Now, we ask the teacher to know whether it is correct or not
- 258 Ng: To me, I think it glows at normal brightness suited to the rated voltage marked by manufacturers. I think it is not necessary ...
- 259 Ti: Yeah, yeah, yeah ... It glows at normal brightness, OK! Increase slowly ... Students conduct a second move.
- 260 Th: All right, it lightens enough ... all right ...
- 261 Ti: OK? White already
- 262 Th: Nearly 3.5 V
- 263 Ti: Nearly how many volts?
- 264 Th: Nearly ... 3.5 V
- 265 Ti: 3.5 V The rated voltage of the bright bulb is 3.5 V.
- 266 Ng: I think it is clear that ...
- 267 Ti: So the brightness is white, all right?
- 268 Ng: ... but their brightness is different. So it is clear that this bulb has low rated voltage
- 269 Ti: The rated voltage of bright bulb is lower
- 270 Ng: ... that of the bright bulb is lower
- 271 Ti: Nearly 3.5, right?
- 272 Th: Yeah.
- 273 Ti: 3.5 V. Therefore, basing on the brightness, we see that their white brightness is the same like this. And the R? Where is the R noted on the paper? After indicating the rated voltage of two bulbs, students move to another reframing activity to search for the explanation of the phenomenon.

According to the power, that is the rated power, the power of the dim bulb. And it has to be the rated power of the dim bulb multiplied by the intensity of the current  $I$

274 Ti: UI, UI, UI, right?

275 Ng: P, P equals to UI

276 Ti: The rated power of the bright bulb is equal to its rated voltage multiplied by its current intensity. But how many milli-amperes did we measure for the  $I_b$ ? And we have  $I_d > I_b \dots I_d > I_b$ . But this power, the rated power, the rated power. We have  $I$ , we can conclude  $I_d < I_b$ . All right! We have a conclusion about the rated voltage. The rated voltage of the dim bulb is higher than that of the bright one

277 Ti: So, which power is higher?

278 Ng: The rated power, right?

279 Ti: Yeah. Now, the rated power ... UI

280 Ng: Yeah, the rated power of ... the dim bulb is higher than that of the bright one. And we can know how to find out those terms

281 Ti: We have found that the rated power of the dim bulb is higher than that of the bright one. Therefore, how come?

282 Ng: How about the power supply?

283 Ti: The same

284 Ng: The higher its rated power is the dimmer it is

285 Ti: Therefore, that is the power supply does not offer enough ...

286 Ng: Yeah, so the bulb which has the high rated power has to be dimmer than the other one that has low rated power

287 Ti: So, the power supply, the rated power of the dim bulb...

#### Reframing activity 6

Through discussion, students point out the difference of two rated powers.

Student makes up the problem for the last reframing activity.

#### Reframing activity 7

Students construe the problematic phenomenon in two ways. First, they account for the phenomenon according to the relationship between the rated powers of the two bulbs and the power of the electrical source.

- 288 Ng: The rated power ...
- 289 Ti: The dim bulb. Now, let's discuss about the dim bulb, OK?
- 290 Ng: Yeah ...
- 291 Ti: The power, the power that the electrical source supplies to it is lower than its rated power
- 292 Ng: Yeah, it is right ...
- 293 Ti: How about the bright one?
- 294 Ng: In short, nearly like that ... The power applied to it is nearly equal to its rated power. So it glows at normal brightness. Nearly ...
- 295 Ti: So this brightness depends on the power ...
- 296 Ng: Yeah
- 297 Th & Ng: Yeah, the rated power. But that power corresponds to the higher rated voltage
- 298 Ng & Th: Yeah
- 299 Ti: Hence, I can conclude that the high rated voltage ...
- 300 Ng: ... But, if the bulb has the high rated voltage, it glows at the proper brightness. Well, now, the bulb which has the high rated power glows dimly, right? So, these two factors are enough to affirm
- 301 To: And how about the power consumed by the dim bulb ...?
- 302 Ng: The U, the bulb which has the high rated power glows dimly. Few moments ago, we measured it already. I saw it is dimmer ... than
- 303 Ti: The rated voltage, OK! ... OK!
- 304 Ng: Ah, is it? It is high. It glows dimly, right?

Students feel satisfied with their work.

- 305 Ti: If it is high, it glows dimly, right?
- 306 Ti: How about...? So let's discuss about the rated voltage ...
- 307 Th: It depends on the ...
- 308 Ng: Let's suppose that the power of the electrical source does not supply enough to ...
- 309 Ti: ... the dim bulb ...
- 310 Ng: ... to the rated voltage ... of the bulb. So it glows dimly
- 311 Ti: So we conclude temporarily that the bulb glows dimly because the output voltage of the electrical source which supplies to it is lower than its rated voltage
- 312 Ng: Yeah
- 313 Ti: The dim bulb ...
- 314 Th: Yeah, all right
- 315 Ti: ... Read please. The output voltage of the power supply is less than the rated voltage of the dim bulb for the dim light bulb
- 316 Ti: It causes the bulb to light up dimly ...
- 317 Ti: Like that, how do we chose the voltage difference in reality?
- 318 Ng: We chose some bulb that has the potential difference ...
- 319 Ti: Now, if we go shopping to buy 2 bulbs. One is marked 6 V, and other is marked 3.5 V. And how do we supply the voltage difference to them so that they glow at normal brightness?
- 320 To: 3 V bulb, and 6 V one. But how about the output voltage supplied by the electrical source?
- 321 Ng: It depends on the output voltage of the electrical source as well

Secondly, the students specify the relationship between the output voltage offered by the power supply and the rated voltages of two bulbs.

#### The resolve

Students bring science concepts constructed to re-examine the problematic phenomenon as testing the authenticity of all the work done. This phase not only leads to a new conclusion, but also searches for implications in reality.

Students search for some applications in reality. They try to bring science concepts built to practice into culture as shopping, working, and so on.

- 322 Ti: Now, we buy two different bulbs, right? One is 6 V and other is 3 V. I question that how do we set up the circuit so that two bulbs glow at normal brightness? Two different circuits, all right?
- 323 Ng: Two different circuits, right?
- 324 To: Two different circuits. One in parallel and other in series ...
- 325 Th: That is ...
- 326 Ti: Well, now, we just buy one, all right? 6 V bulb. And how do we set up ... so that it glows at normal brightness?
- 327 Ng: We use the 6 V power supply to try ... The 3 V one with 3 V power supply ...
- 328 Ti: ... in reality
- 329 Ng: Yeah ...
- 330 Ng: But a while ago, we mentioned about the dim light bulb and the bright light one. This problem does not ... yet ...
- 331 Ti: The bright light bulb
- 332 Th: In short ... there must be ...
- 333 Ng: Recently, we have just said that the resistance of the bright light bulb is greater than that of the dim light one. Of course, all right! We concluded this from the beginning. The intensity current of the bright light bulb is lower than that of the dim light one. All right! The two, right?
- 334 Ti: It demonstrates in the power
- 335 Ng: It demonstrates in the power, and the power ... the power, all right! A while ago, we have concluded about the power. It means that the power of the bright bulb is lower than that of the dim one.

Students bring science concepts--the rated power and the rated voltage--they have constructed to re-examine the problematic phenomenon for the conclusion.

We conclude nothing up to now. And now, we explain by relating with the rated power and the rated voltage. If the electrical source supplies some output voltage, which is equal to its rated voltage, the bulb will glow at normal brightness according to the ratings of the manufacturer

- 336 Ti: The power ... The second circuit? Do we need to have a comment?
- 337 Th: We draw the conclusion ... as Ng has shown, OK?
- 338 Ti: The power ... the consumed power ... consumed ...
- 339 Ng: The consumed power ...
- 340 Ti: ... equal to ...
- 341 Ng: ... equal to ...
- 342 Ti: .....equal to the rated power. So the bulb will glow at normal brightness, right?
- 343 Ng: ... fitted with normal brightness
- 344 Ng: Saying directly, the consumption requirement, but not the requirement of some people and that of other people
- 345 Ti: ... The consumption requirement, OK!
- 346 Ti & Ng: Now, this consumed power, this consumed P... if consumed power is lower than the rated power of the bulb, it glows dimly
- 347 Ng: It glows dimly, not at normal brightness ...
- 348 Ng: ... the second thing is the potential difference
- 349 Ti: This power contains the potential difference ...
- 350 Ng: OK ...
- 351 Ti: OK?

- 352 Ti: Here is the power. We have two major conclusions. And but how about the resistances?
- 353 Th: We concluded about the resistances
- 354 Ng: I think the resistance of the dim light bulb is smaller than that of the bright light one. The bulb's resistance, the filament ...
- 355 Th: According to the figure (b), these two bulbs are the same. Connect them in parallel to the same voltage difference, 3 VDC, offered by the power supply. And what's going on to them?
- 356 Ti: These two bulbs are the same, right?
- 357 Ng: Try first, try to experiment with two same bulbs. They have the same brightness, and ...
- 358 Ti: Vary the voltage difference up to 3 V first, 3 V, right? Now, take out to test it
- 359 Th: You measure conversely!
- 360 Ti: As the minus terminal of the VOM is connected to the plus terminal of the power supply, it deflects conversely
- 361 Ti: Down, all right ...
- 362 Th: OK ... OK?
- 363 Ng: OK?
- 364 Ti: Connect it. They are the same. Turn on! Are they the same? Two bulbs have the same brightness
- 365 To: Now, we recognize that the consumed power corresponds to the rated power. It means that the consumed power is nearly equal to the rated power, right? And the current corresponds to the rated voltage ... It is also the rated current, right?
- 366 Ti: Yeah ...

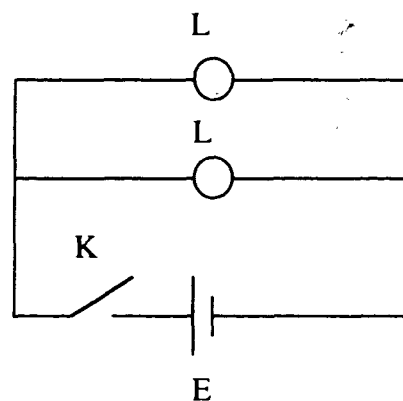

This experiment is focused on two points:

- provide opportunities for students to apply science concepts they have constructed in the second experiment to explain the phenomenon.
- give students experiences for solving a complicated problem in the fourth experiment.

- 367 To: Two bulbs glow at the same normal brightness. This is the output voltage of the power supply. How about their rated power?
- 368 Ti: Comment this please
- 369 To: How about their rated powers? Their rated voltages?
- 370 Ti: ... equal to each other
- 371 To: How about the currents flowing through these bulbs?
- 372 Ti: ... equal to each other as well.
- 373 To: Yeah, they are the same as well ...
- 374 To: Now ...
- 375 Ng: The ... the ... because this bulb is marked on here
- 376 Ti: They are the same, two bulbs ...
- 377 To: Here, we do not know. We cannot determine the rated characteristics on the bulb
- 378 Ti: These two bulbs are the same
- 379 To: Now ... no ... we can say that two bulbs are the same in the rated power ... the rated voltage. What does it mean?
- 380 Ng: It means that the currents flowing through two branches are equal each other ... equal each other
- 381 Ti: The currents through these two branches, the currents through these two branches, two branches ...
- 382 Ng: Two branches. It means that each branch has a bulb
- 383 Ti: The same, OK! ... Is there any thing else?



- 384 Th: The same rated voltage as well. The rated voltage, the same rated voltage, right? Based on that, we can conclude about the rated power ...
- 385 Ti: The same rated power, right? The same, all right! Based on this circuit, we can draw out three conclusions, right? Ng? Draw out these three conclusions. Now, we insert resistors to this circuit, all right? Now, we set up another circuit ...
- 386 Th: Circuit G
- 387 Ti: Adjust the voltage of power supply to 9 V. Connect two terminals to two resistors. Ask our teacher which are they?
- 388 Ng: Resistors we had a while ago
- 389 Th: Yeah, we introduced them
- 390 Ti: Where are they?
- 391 Th: Here
- 392 Ti: Separate this circuit ... Two branches ...
- 393 Ti & Ng: Two same bulbs ...
- 394 Ti: We name them L. Now, we connect to R1. Here is R1. Connect to R2. Here is R2. Two bulbs are the same. Now, this circuit is included two bulbs and two resistors. Do you see? What do we comment about these bulbs and their brightness?
- 395 Th: They are different. One is bright, and another is dim
- 396 Ti: One bright, and one dim. Now, the power of the dim light bulb ... What have we concluded about the power of the dim one?
- 397 Th: ... Equal each other ...
- 398 Ti: The consumed power of the dim light bulb is lower than that of the bright light one, right?

Students will bring conclusions from this experiment to deal with the complicated problem in the fourth experiment by "seeing" the problem in a new way.

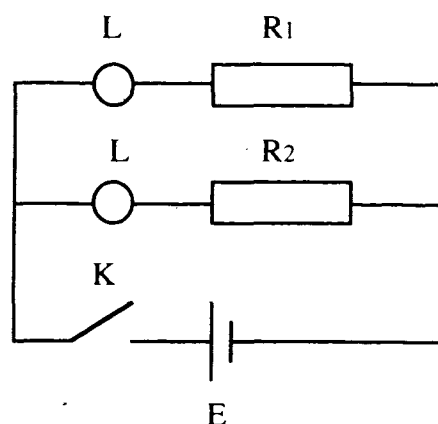

The purpose of this experiment is to help students:

- apply new meanings of science concepts that they have constructed in the second experiment, and experiences gained from the third experiment to solve a complicated problem

- increase the cognitive demand by engaging students to deal with the technical problem solving

It should be thought that the situation in this experiment is a limited form of reflection-in-action. Students can apply a routine application of existing science concepts and procedural knowledge to search for solution.

399 To: No, they are not equal each other. At first, when we have not connected two resistors ( $R_1$  and  $R_2$ ), their rated powers are the same

400 Ti: Yeah, the same ...

401 To: So they have the same rated powers and rated currents. After we insert two resistors to the circuit, then one glows at normal brightness, and the other glows at the proper brightness. Now, basing on the bright light bulb and the dim light one, how can we explain? We have to notice which character terms that we have to base on to explain their different brightness. Now, which ones can we base on?

402 Ti: We set up a parallel circuit with two resistors in series with two same bulbs. We see that one is dim because the electrical source does not supply enough electrical energy compared with its rated power. It means that  $P_{d,c} < P_r$ . Therefore, it is dim, the dim bulb, all right? Now, If  $P_c$  is higher or nearly its rated power, it is bright, right? Therefore, the consumed power of the dim bulb, the consumed power, all right? Saying exactly, all right! The consumed power of the dim bulb is lower than that of the bright bulb ... The consumed power of the bright bulb is higher ... no ... lower than that of the dim bulb

403 Ti: OK! The consumed power of the resistance is rather low, and the remainder of the power of the electrical source shares to the bright bulb. Now, we see that the consumed power of the bright bulb equals to its rated power

404 To: Now, we see that the bulb is bright. It means that its consumed power is nearly equal to its rated power. How about the dim one?

405 Ti: How about its consumed power?

406 To: ... To the dim bulb, the consumed power is lower than its rated power

### Problem setting

In order to solve this problem, students use surface features as sorting science concepts to define the problem.

It is worth to distinguish textbook problems from real-world problems. For real-world problems, facts lie in and depend on the particularly practical case from the experiment. Therefore, students have to search for the facts by "seeing" the problem in a new way. Students' discussion about solving the problem leads to the first reframing activity.

- 407 Ti: Yeah, all right
- 408 Ti: The rated power of the bright bulb, right? How?
- 409 Ng: The bright bulb ...
- 410 To & Th: ... is nearly equal to the rated power
- 411 Ti: That is ... that is ... the rated power, all right!
- 412 To: The consumed power of the dim bulb is lower
- 413 Ti: Yeah, it is lower than its rated power; and their rated powers are the same. So we conclude the consumed power of the bright bulb
- 414 Ng: The consumed power of the bright bulb is higher than that of the dim bulb
- 415 Ti: Their rated powers are the same ... But in order to have the same powers distributed to two branches ...
- 416 To & Ng: The consumed power of the bright bulb is higher than that of the dim one
- 417 Ti: The consumed power of the ... bulb ... higher than ... this ... These two things are the same, right?
- 418 Ng: Yeah ... because two ratings are the same
- 419 Ti: ... and in order to have these two things - depended on each other, the consumed power ... the dim bulb ...
- 420 Th: We have ... the current flowing through the bright bulb is higher than that of the dim one
- 421 Ti: OK! We can conclude these things, right? So ... do you agree? Some more papers, please
- 422 Th: Yeah ...
- 423 Ti: Some more papers, please!

- 424 Ng: First, the consumed power of the bright bulb is higher than that of the dim one. Second, at the beginning, we agreed that these bulbs are the same. Well, we can say that ...
- 425 Ti: No, basing on the characteristics of the two same bulbs, we deduce about these two consumed powers. The consumed power of the bright bulb is higher than that of the dim one. Now, how about the power consumed by each branch? P of  $X_1$ . Now, we name P, OK?
- 426 Ng: No, we do not name  $X_1$  for the resistance
- 427 To: Now, we can call  $P_{x_1}$ . It is OK ...
- 428 Ng: We can call it  $P_{R,b}$  as well
- 429 To: ... corresponds with the bright bulb
- 430 Ng: ... The X of the bright bulb as well
- 431 Ti: Which one? Which is the X of the bright bulb?
- 432 To: Ti asks about the X of the bright bulb
- 433 Ng: We name it like that in order to call easily
- 434 Ti: This one?
- 435 Ng: Yeah
- 436 Ti: We name this one the X of the bright bulb
- 437 Ng: Yeah, the X of the bright bulb
- 438 Ti:  $X_b$  has the small size, right?  $X_b$  has the small size, right?
- 439 Ng: Yeah
- 440 Ti:  $X_a$  has the big size. It is longer ... bigger ...
- 441 Ng: Yeah

- 442 Ti: It is the size not the resistance, all right! Now, the consumed power  $P_x$  of the resistance plus to the consumed power of the bulb,  $P_b$ , right? Plus to the  $P_{x2}$ , and plus to the consumed power of the dim bulb .... are ...
- 443 Ng: We should call them the dim bulb and the bright one. We will confuse  $R_1$  with  $R_2$  if we note like this
- 444 Ti: The bright bulb, all right! The dim bulb, all right!
- 445 Ng: Yeah, the dim bulb...
- 446 Ti: The  $P$  of the power supply, right?
- 447 Ng: Yeah
- 448 Ti: Is it right? Therefore, the consumed power plus to consumed power of the resistor, the consumed power ... All right!
- 449 Ng: Yeah ...
- 450 Ti: ... of the bulb plus to the consumed power of the resistor. All are equal to the power of the electrical source
- 451 Ti: Any thing else?
- 452 Ng: All right!
- 453 Ti: Basing on those, we can conduct to conclusions
- 454 To: Now, we mention clearly about the power, OK!
- 455 Ti: The power,  $P$  is the power
- 456 To: Now, we have to mention about the consumed power of the bulb. On this branch, ... plus to the power of resistor  $X$  ...
- 457 Ti: We say clearly that ... we say now like this ...

- 458 To: ... No, the consumed power of the first branch. What is the power of the first branch equal to ...?
- 459 Ti: Read it!
- 460 Ng: It equals to the power
- 461 Ti: P
- 462 Ng: Name it  $P_1$
- 463 Th:  $P_1$ , OK!
- 464 Ti:  $P_1$ . Yeah,  $P_b$
- 465 Ng:  $P_1$  is equal to P of the bright bulb plus  $P_{x,b}$
- 466 Ti:  $P_{c,b}$ , OK! The first branch. Here is it, right? Here is the second branch. They have the same formula, but nothing else, right? I repeat in order to make it clear
- 467 Ng: Yeah, OK!
- 468 Ti: ...  $P_2$ , all right! Plus the consumed P of, the dim bulb, right? So they are equal to the power of the branch right? Adding two branches, is it the power of electrical source?
- 469 Th: So what comment do we have about that?
- 470 Ti: Now, all right! Now, we have this ... We had concluded about the power,  $P_b$ . It is higher ... so that it is equal to a constant. The electrical source does not change. ... In order to have this unchanged, this P, the consumed power of the bright bulb is higher than that of the dim one. How about the relationship between  $P_{x1}$  and  $P_{x2}$ ?
- 471 Ng:  $P_b > P_d$
- 472 Ti: Yeah,  $P_{b,b} > P_{b,d}$
- 473 Ng: So,  $P_{b,b} > P_{b,d}$
- 474 Ng: So the resistor which is in series with the bright bulb has to be lower ...

- 475 Ti: The P of the resistance
- 476 Ng: ... No, it is higher than the power  $P_x$
- 477 Ti:  $P_{x,b}$ ?
- 478 Ng:  $P_{x,b}$ , all right!
- 479 Ng: The power source  $P_x$ ,  $P_{x,b} < P_{x,d}$
- 480 Ti:  $X_1$  is the size ...
- 481 Ng: OK, we conclude that P ...
- 482 Ti: Yeah, this P
- 483 Ng: We rationalize ... P;  $P_{x1}$ ;  $P_{x,b}$
- 484 Ti: ... and what is  $P_{x1}$  equal to?
- 485 Ng: U is lower than  $P_{x,d}$  ...
- 486 Ti: ...  $(U^2/R_1)$ .  $R_1$  is the bright bulb
- 487 Ti: P is equal to  $(U^2/R_1)$
- 488 Ng: All right! All right!
- 489 Ti: OK!  $P_1$ , all right!  $P_{x2} = (U^2/R_2)$ , right?  
But these voltage differences are the same
- 490 To: How about U?
- 491 Ti: ... The circuit is in parallel
- 492 Ng: ... in parallel, the voltage difference is the same
- 493 To: Why is U the same?
- 494 Ti: Yeah, U is the same. Therefore, we have the ...  $P_{x1}$  multiplied by  $R_1$  equals to  $P_{x2}$  multiplied by  $R_2$ , right?  $P_{x1}$  multiplied by  $R_1$  equals to  $P_{x2}$  multiplied by  $R_2$ , right? Do you agree about this?
- 495 To: Like this? Ti said that the voltage differences on  $X_1$  and  $X_2$  are equal to each other, right? It is not sure
- 496 Ti: Just on this branch ...

- 497 To: ... on this branch
- 498 Ti: On this branch, but not on that part of its branch
- 499 To: So what is the  $P_x$ ?
- 500 Ti:  $P_{x1}$  is the consumed power of  $X_1$  ...
- 501 Ti: Yeah! ...  $P_b$  is the consumed power of the bright bulb
- 502 To: The consumed power of this  $X_1$  is  $(U^2/R_1)$ , but Ti said that  $U^2$  is also used for  $(U^2/X_1)$ . Do you see? They cannot be the same at all ... They cannot be the same at all
- 503 Ng: We also have the power of the bulb, right?
- 504 To: The power of  $X_1$  is equal to  $(U^2/X_1)$ .  $U$  is the voltage difference between two terminals of this branch. Why are the voltage differences between two terminals of the resistor and these two terminals equal to each other? They cannot be equal at all
- 505 Ti: The same current. The current is ... the same
- 506 To: It is not sure
- 507 Ti: ... the same on the branch
- 508 Th: Not yet
- 509 To: Where?
- 510 Th: ... on this branch...
- 511 To: No ...
- 512 Ng: The current on one branch is the same
- 513 To: All right! Is it equal to  $U$  multiply by  $I$ ;  $P$  equals to  $U$  multiplied by  $I$ ?
- 514 To: Now, like this ...
- 515 Th: We call  $RI^2$ , OK?

Students fail to deal with the problem by using quantitative understanding. This leads to an argument for solving the problem.

Here, through discussion, students shape misunderstandings about using science concepts during the course of knowledge representation.



516 To: Now, let's consider this please. The consumed power of the bright bulb is higher than that of the dim one, right?

...

517 Ti:  $P_b > P_d$

518 To: ... As reasoning, the consumed power of  $X_1$  plus the consumed power of the bulb equal to the power for the branch

519 Ti:  $P_1 = P_{x1} + P_{b,b}$ , right?

520 To: The power of the electrical source equals to the consumed power on the first branch

521 Ti: P on the first branch

522 To: That is the power of electrical source delivered to the first branch. Now, the power of the electrical source distributed to the second branch is  $P_2$ . And  $P_2$  equals to consumed power of  $X_2$  plus the consumed power of the dim bulb. We argue that the consumed power of the bright bulb is higher than that of the dim one, right? In order to have these unchanged quantities, is the power of  $X_1$  higher ... no, lower than that of  $X_2$ ? Slowly, adding  $P_{x2}$  and  $P_d$ , we get a constant ...

523 To: OK! Consider that ... that quantity is unchanged ...

524 To: ... and we argue that the consumed power of the bright bulb ...

525 Ti: Yeah, but the consumed power of the bright bulb is higher than that of the dim one. We had this

Students use qualitative understandings to explain the distribution of the power among that of the power supply and those of two branches of the parallel circuit. Students then use qualitative understanding to search for the solution. They establish a quantitative equation expressing the distribution of power in the parallel circuit as seen in utterance 519. From this equation, they use hypothetico-deductive reasoning to identify the relationship between resistances and the currents flowing through two branches of the circuit in utterance 556. However, students cannot complete the task by using the integrated scientific skill of defining operationally because they do not have the fact given by the problem.

526 To: This one? Now, let's consider the intensity of the current. Here is ...  
Now, the consumed power of the bright bulb is higher than that the dim one. These two terms added together, then plus the power of  $X_1$ , plus the power of  $X_2$  ... We correct this next few moments, OK! The total of  $P_{x1}$  plus  $P_{x2}$  plus ... right?

527 To: ...  $P_{c,b}$  ... plus  $P_{c,d}$  are equal to the unchanged power of the electrical source

528 Ti: Yeah, all right! It equals to a constant

529 To: ... We also argue that the consumed power of the bright bulb is higher than that the dim one

530 Ti: All right!

531 To: In order to make this quantity unchanged, is the consumed power ... of the ... bulb ...? It means that ...  $P_{x2}$  is higher than  $P_{x1}$ , right? Now, we see on ...

532 Ti:  $P_{x2}$ ,  $P_{x2}$  is higher than  $P_1$  ...

533 To: Now, let's check it, OK!

534 Ng: This one is high, so that one is low, right?

535 Ti: This one is higher than that one, all right? We have that this one is low and in order to have this to be a constant

536 Ng: Why are not these terms named  $X_b$ , and  $X_d$ ? If not we do not know which one is  $X_1$  and which one is  $X_2$ .  $X_1$ ,  $X_1$  in series with the bright bulb, is one that has the small size. We are going to correct them next few moments

537 To: Here is ... We base on the figure. Let's see this figure. The consumed power of the bright bulb is higher than that of the dim one ...

538 Ti: All right!

- 539 To: ... But the consumed power of the two branches ... in order to have the powers of two branches unchanged, the consumed power of the bright bulb is higher than that of the dim one. In order to compensate this, the consumed power of  $X_2$  is higher than that of  $X_1$ , right?
- 540 Ti: Yeah, the consumed power of  $X_2$  is higher than that of  $X_1$
- 541 To: Yeah
- 542 Ti: Let's check it please
- 543 To: The power for the resistor, is it the consumed one?
- 544 Ti: The ... the consumed power of the resistor
- 545 Ti: The consumption is exactly the loss, right?
- 546 Th:  $P_{x2}$  is higher than  $P_{x1}$ . It is right
- 547 To:  $P_{x2}$  is higher than  $P_{x1}$ , all right!
- 548 Ti: All right!
- 549 To: Is it right? ... And according to that formula of the power, what is it equal to ...? The power of  $X_1$ , the power of  $X_1$ . Is the product of the resistance  $X_1$  multiplied by  $I_1$  square, equal to  $R_1 I_1^2$ ?
- 550 Ti:  $I_1^2$ , right?
- 551 To: ... the intensity of the current ... flowing through ...
- 552 Ti:  $R_2$  multiplies by  $I_2$  square makes  $P_{x2}$
- 553 Th:  $I_2^2$
- 554 Ti:  $R_2 I_2^2$
- 555 Th & Ti: ... higher, higher than  $R_1 I_1^2$
- 556 To: Please note carefully, Ti

- 557 Ti: ... and these intensities of the current are the same
- 558 Ng: No, they are different. These are different. These ...  $I_1$  is higher than  $I_2$
- 559 Th: ... They are different
- 560 Th: This is the I on each branch
- 561 Ng: The I on each branch,  $I_1 > I_2$
- 562 Ti: Yeah, all right!
- 563 Ng: Is it right? Right?
- 564 To: Now, let's establish the ratio. We have  $R_1$  is higher than  $R_2$
- 565 Ti: No ...
- 566 To: Now, here is, the power of  $X_1$  is lower than that of the  $X_2$ . But the  $P_x$  equals to  $R_1$  multiplied by  $I_1$  square. And because  $(R_1 I_1^2)$  is lower than  $(R_2 I_2^2)$ , after establishing the ratio  $R_1$  ...
- 567 Ti: Yeah, all right
- 568 Th: Establish the ratio, all right!
- 569 To: Establish the ratio. It is not necessary to note, I have it here. The ratio  $(R_1/R_2)$  must be lower than that of  $(I_2^2/I_1^2)$ , right?
- 570 Ti: All right! How do we know,  $I_1$  and  $I_2$ , that  $I_1$  is higher than  $I_2$ ?
- 571 Ng:  $I_1 > I_2$
- 572 To: Now, we continue considering. Are these bulbs the same?
- 573 Ng: It is brighter. Therefore, the current is higher
- 574 Ti: The same
- 575 Th: Two bulbs are the same
- 576 To: Let's turn them on

### Reframing activity 1

Students frame the problem by conducting a hypothesis-testing experiment to confirm the hypothesis ( $I_1 > I_2$ ) discussed.

577 Th: The bulb lights more brightness.  
Therefore, the current through it is higher

578 To: So, the current through the bright bulb is higher than that of the dim one...

579 Th: Yeah ...

580 To: Is  $I_2$  lower than  $I_1$ ?

### Reframing activity 2

581 Ng: And ... the current through each branch is the same, all right! They are the same for each branch

With the data gathered from the hypothesis-testing move, students conduct a move-testing experiment to indicate the difference of two resistances.

582 To: Continuing like this. Now, we consider ... Now,  $I_2$  is lower than  $I_1$ , right? Therefore, the ratio  $(I_2/I_1)$  is less than 1. Recently, we have had the ratio  $R_1/R_2$  is less than the ratio  $(I_2^2/I_1^2)$ ; and we have  $(I_2/I_1)$  is less than 1 as well. From this ratio, we see whether it is much more less than 1. Therefore, the ratio  $(R_1/R_2)$  is certainly less than 1

583 Ti: All right!

584 To: Therefore, we conclude that  $R_1$  is lower than  $R_2$ , right?

They conclude that  $R_1 < R_2$ .

585 Th: It is right.

586 Ti:  $R_1$  is lower than  $R_2$ , it is the R of the bright bulb ...

587 To: So the resistance  $X_1$  is lower than that of  $X_2$

588 Ti: You solve it, right?

589 To: Yeah, we have just discuss to solve it. All right! ... Now, here is ...  $X_1 < X_2$ , right? Now, we turn it up side down to see which resistor?

590 Ng: Some times we call R, and some times we call X ...

591 Th: All right!

592 Ng: All right!

593 Ti: All right! So ...

594 To: Now, here is ... Now,  $X_1 < X_2$ , right?  
Now, we turn it over to observe the resistor under it

595 Ng: Which one? Some times we call R, and some times we call X ...

596 Ti: We call X, but To calls R

597 Ng: All are correct, but we are unanimous how to name them

598 To: Now, we turn it up to observe the resistor under it

599 Ti: Already

600 To: Let's turn over, please. Now, we see that ...  $R_{x1} < R_{x2}$ . Is the resistor  $R_{x1}$  ... ?

601 Ti: R,  $R_1$ , right?  $R_1$  is the one that has the small size

602 To: So how about its resistance?

603 Ti:  $R_2$  has a big size

604 Ng: ... smaller

605 Ti: What do we conclude about  $R_1$ ?

606 Ng: We conclude that  $R_1 < R_2$

607 Ti: This conclusion? OK! Let's test them

608 Ti: Now, the resistor has the small size

609 Ti: All right!  $R_1$  is lower than  $R_2$ . That is enough to understand ... Here is ...  $R_1$  has the big size ...

610 To: OK! Let's give the conclusion

611 Ti: Basing on the above conclusion, we have  $R_1 < R_2$

They reach to the conclusion:  $R_2 > R_1$ .

612 Th: Yeah ...

613 Ti: Now, are we sure about that? Now, we take it out to measure

- 614 To: Now, like this ... We have concluded already ... We see that one bulb is bright, and the other is dim, right? We are seeing it
- 615 To: Ti, please hold it to see, OK?
- 616 Ti: Here is ...
- 617 To: How about this resistor?
- 618 Ti: It consumes less power
- 619 To: Recently, we have discussed
- 620 Ti: This one is bigger
- 621 Ng:  $R_1$  is lower
- 622 Th:  $R_1$  is lower
- 623 Ti: Hence,  $R_1 < R_2$ . It's correct. Exactly,  $R_1 < R_2$
- 624 Th: Yeah
- 625 Ti: Yeah ... but  $R_1$  has small size,  $R_2$  has big size, right?
- 626 Th: Yeah
- 627 Ti: Now, what are we doing? Measure?
- 628 Th: OK, let's measure it
- 629 Ng: We see that the resistor  $R_1$  is in series with the bulb  $L_1$ . It is brighter; and that the time the resistor in series with the bulb, the bulb ...
- 630 Ti: It means that its value is lower So it consumed less power ...
- 631 Ti & Ng: ... it saves the power for the bright bulb ...
- 632 Ti: ... Its consumed power is nearly equal to the rated power, so it glows at normal brightness. The big resistor consumes more power and this bulb consumes less power. Therefore, it is lower than that of the rated power so it is dim. Is it right?

- 633 Th: Now, let's measure it
- 634 Ng: ... much more lower compared with the rated power
- 635 To: Now, like this ... in order to make sure that it is correct, let's argue about the voltage difference ... all right! Now, we see ... For the bright bulb, the voltage difference that inserts to its terminals equals nearly to its rated voltage ...
- 636 Ti: Yeah ...
- 637 To: For the dim one, the voltage difference inserting on its terminals is lower than its rated voltage. Thus, it is dim. To the dim one ...
- 638 Ti: To you, the rated voltage ...
- 639 Th: All right! ... Nearly equals to the rated power, therefore, it is bright
- 640 To: Is it right? ... It is bright.
- 641 Ti: But U is the one of this part
- 642 To: No, now, we just see that ... U
- 643 Ti: No ...
- 644 Ng: U is the rated voltage of the bulb
- 645 To: If the voltage difference inserting on its two terminals nearly equals to its rated voltage, it is bright
- 646 Ng: The resistance of the bulb, all right!
- 647 Th: Exactly
- 648 To: ... And ... when the bulb is dim, how about the voltage difference? The voltage difference inserting on its two terminals is lower in comparison....
- 649 Th & To: ... with its rated voltage
- 650 Ti: All right!

### Reframing activity 3

In order to make sure that the solution is correct, students move to the third reframing activity by conducting another move-testing experiment.

In this episode, students use the concept of voltage as a mean to indicate the difference of two resistances. Similarly, procedure knowledge and qualitative understandings are exhibited for searching the solution. They establish an equation to explain the phenomenon in term of the voltage in utterance 671. They then use hypothetico-deductive reasoning to derive the equation:  $U_{R2} > U_{R1}$  in utterance 692.



651 To: Is it right? According to the formula, Ti, please note it. What is U equal to ...?

652 Ti: U!

653 To: The voltage difference on the branch, all right! The voltage difference on the branch ... Here is ...

654 Ti: Reason please. Note it, OK?

655 To: It's not necessary to take note. Here is ... U is the voltage difference on the branch, but they are in parallel. So they exactly equal to the voltage of the power supply, right?

656 Ti: U!

657 To: Yeah ...

658 To: No, the U is ...  $\{U_{R,1} + U_{b,b}\}$  (1)

659 Ti: All right!

660 To & Ng: It also is the voltage difference inserted on the second branch, because it is in parallel ...

661 To, Ti & Th: ... So  $\{U_{R,2} + U_{b,d}\}$  (2)

662 To: From this, we add (1) and (2)

663 Ti: Yeah, addition ...

664 To & Ti:  $\{U_{R1} + U_{bb}\}$  equals to the output voltage of power supply, right?

665 Th: ... equal to the U of the power supply, right?

666 Ti: What is the U?  $\{U_{R1} + U_{b,b}\}$ , right?

667 Th: ... U of the power supply, OK?

668 Ti: Where is the conclusion we have had?

669 To: Here is ...

670 Ti: Where is the conclusion?

671 To: Now, after bringing over these terms of the equation to the other side, we add ... wait a moment ...  $U_{R1} + U_{b,b} = U_{R2} + U_{b,d}$ , right? ... equals to  $U_{R1} - U_{R2}$  ...

672 Ti:  $U_{R1}$  is the  $U_b$ .  $U_{R2}$ , this one, is  $U_d$ ,  $U_d$ ?  
All right! It equals to the output voltage of power supply

673 Ti: I am going to do an addition for you,  $U_{b,d}$ , right?

674 To: Yeah

675 Ti: But ...

676 To: Bring over these terms to the other side, we see  $U_{b,b}$  is the voltage difference inserted on the bright bulb minus that of the dim one

677 Ti: The  $U_{b,d}$ ?

678 To: It equals to the voltage difference ...

679 Ti & To: ... equals to  $U_{x1}$

680 To:  $U_{x1}$  minus ... the voltage difference of the ...

681 Ng: ... the voltage difference of  $R_1$ , all right!

682 Ti:  $U_{R1}$  minus  $U_{R2}$

683 To: ... minus the voltage difference of the  $X_2$ . But, recently, we have reasoned that is the voltage difference on the bright bulb higher than that of the dim one?

684 Ng: The voltage difference of the bright bulb

685 Ti: Yeah, exactly

686 To: Is it right? The voltage difference on the bright bulb is higher than that of the dim one

687 Ti:  $U_{b,b} > U_{b,d}$

688 To: ... and in this term of the equation, that  $U_{b,b}$  is higher than  $U_{b,d}$ . It must be positive

Students use the result ( $I_1 > I_2$ ) from the hypothesis-testing experiment and the equation  $\{(R_2/R_1) > (I_1/I_2)\}$  to indicate the difference of two resistances.

- 689 Th: All right! Positive, positive
- 690 Ti: The consumed voltage of the bright bulb is higher than that the dim one
- 691 To: ... Therefore, corresponding to that, this side of the equation must be positive, mustn't it? ... Subtract  $U_{R2}$  from  $U_{R1}$
- 692 Ti: Subtract  $U_{R2}$  from  $U_{R1}$ , right? And we have  $U_{R2} < U_{R1}$
- 693 To: Please take note carefully, Ti
- 694 Ti: Here is U
- 695 Ng:  $U_{R2} > U_{R1}$
- 696 Th: ... less than
- 697 To: ... greater ... Th!
- 698 Th: Ah ... greater
- 699 Ng: ... This term is  $U_{R2}$  minus  $U_{R1}$ , and we have  $U_{R2}$  is greater than  $U_{R1}$  ...
- 700 Ti:  $U_{R2}$  minus  $U_{R1}$ , all right!
- 701 Ng: ... And we have  $U_{R2} > U_{R1}$ . This one is higher, right? All right!  $U_{R2}$  is greater than  $U_{R1}$
- 702 To: Here is ... I have already! Now,  $U_{b,b}$ , the voltage difference on the bright bulb, is higher ...
- 703 Ti: We can conclude this one
- 704 To: ... than that the dim one. So the voltage difference on R ...
- 705 Ti:  $U_{R1}$  equals to the ratio  $(I_1/R_1)$ , right?
- 706 Ng: Multiply, right? How do you have the ratio of  $(I/R)$ ?
- 707 Ti:  $U_{R1} = I_1 R_1$  ...  $I_1$  ...
- 708 Ng: All are ...
- 709 To: ...  $U_{R2} = R_2 I_2$

- 710 Ng: ...  $I_1$ , is it right?
- 711 Th:  $I_2$
- 712 Ti:  $I_2 R_2 \dots U_{R_2} = I_2 R_2$
- 713 To: Here is ...  $R_2 I_2 > R_1 I_1$ . We establish the ratio. And we have  $(R_2/R_1) > (I_1/I_2)$ , right?
- 714 Ti: We have ...
- 715 Th: Where are they from?
- 716 Ti: We have, therefore,  $R_2 I_2 > R_1 I_1$ , right? I, all right!
- 717 Ti: Yeah, from here, from the multiplication
- 718 To: Because the voltage difference on the resistor ...
- 719 Ng: ... the voltage difference of  $U_x$  is higher, right?
- 720 To: ... the voltage difference on  $R_1$  is higher than X ...
- 721 Ti: All right, we have this ...
- 722 To & Ng: Then we are going to establish the ratio ...
- 723 Ti & Th:  $(R_2/R_1) > (I_1/I_2)$ , all right!
- 724 To & Th: ... Recently, we have found out that  $I_1$  is greater than  $I_2$
- 725 Ti: But  $I_1 > I_2$
- 726 To & Th: It means that it is greater than 1
- 727 Ti & Th: So, we have:  $(R_2/R_1) > (I_1/I_2)$ , and  $(I_1/I_2) > 1$ . Therefore, we have:  $(R_2/R_1) > 1$ . Thus,  $R_2 > R_1$
- 728 Ng & Th: All right!
- 729 To: Now, like this ... We base on the following characteristics to reason the voltage differences and powers, their powers, right? Recently, what powers do we have to base on to explain?

### The resolve

Students re-examine all work done in the second phase of the reflective learning cycle from utterance 728 to utterance 735.

- 730 Ti: The consumed power
- 731 Th: The rated power ... if the consumed power is around some rating ...
- 732 Ti: The consumed power of this resistor, it is high
- 733 To: It means that we base on the power and the voltage difference. For two cases, we conclude that  $R_2 > R_1$
- 734 Ti: The power ... the power, all right!  $R_2$  is the resistor which has the big size ...  
Now, we take it out to measure
- 735 Th: Turn off the power supply, please ...
- 736 To: Now, before we measure, please observe on the resistors. Are they marked their data? Are they marked their values?
- 737 Th & Ti: Nothing!
- 738 Ti: Wow, these resistors are so hot!
- 739 Ng: All right!
- 740 Th: Not yet ...
- 741 Ti: Where is our conclusion paper? Where do our conclusion paper disappear?
- 742 Ng: If some thing is not necessary for this experiment, let's bring it here
- 743 Ti: Right? The plus terminal is connected to the switch K. Measure the resistance by the Wheatstone Bridge. Replace the wire ACBD by the wire FM. Do we introduce instruments? This is the wire Bridge used to measure the resistance
- 744 To: We introduced these at the beginning. So we need not to do that again ...
- 745 Ti: Now, the plus terminal of the power supply is connected to the switch K ... the terminal ... the other terminal of the switch K to the terminal A, which is the one connected to L with the resistor X. We have to measure X

In this section, the researcher discusses several elements as constitutive for the problems with the traditional teaching laboratory to represent the authentic view of science. As criticized in Chapter Two, traditional laboratory is exercises that follow "cookbook" format, from which students simply follow predetermined procedures to gather and record the data without a clear sense for the purpose of practical activities.

- 746 Ti & Ng: Which one first?
- 747 Ti: We measure the small one, OK! It is R
- 748 To: First, we measure the resistor which has the small size
- 749 Ti: All right!
- 750 Th: OK! Let's measure R<sub>1</sub>
- 751 Ti: The switch K is connected to the Bridge. And X is connected to the terminal D. The terminal D is the junction of three branches. Connect to the resistor and the galvanometer G ...
- 752 Ti: Yeah, all right
- 753 Th: Wait a moment. Let's make it shorter
- 754 Ng: All right! Let's connect it
- 745 Ti: Now, the plus terminal of the power supply is connected to the switch K ... the terminal ... the other terminal of the switch K to the terminal A, which is the one connected to L with the resistor X. We have to measure X

- 746 Ti & Ng: Which one first?
- 747 Ti: We measure the small one, OK! It is R
- 748 To: First, we measure the resistor which has the small size
- 749 Ti: All right!
- 750 Th: OK! Let's measure R<sub>1</sub>
- 751 Ti: The switch K is connected to the Bridge. And X is connected to the terminal D. The terminal D is the junction of three branches. Connect to the resistor and the galvanometer G ...
- 752 Ti: Yeah, all right
- 753 Th: Wait a moment. Let's make it shorter

The experimental tasks have low cognitive structure and provide a context that precludes the reflective thought and concentration. They have to memorize faithfully theoretical concepts with little understandings.

The fact that students just spent one hour to complete this experimental task. During five year experiences in teaching laboratory, the researcher recognizes that students expended the remainder of lab periods in talking, running around to other experiments to watch their friends' work, or going home.

- 754 Ng: All right! Let's connect it
- 755 Ti: Let's ask the teacher whether it is correct or not
- 756 To: Let's cram those under the box
- 757 Ti: This wire Bridge, all right! The purpose is to measure the resistor  $X_1$ .  $R_0$  is equal to the product of  $R_0$  multiplied by the ratio ( $L/L'$ )
- 758 To: All right
- 759 Ti: ...  $R_0$  is ...
- 760 To: When the Bridge is balanced, we have this formula
- 761 Ti: Yeah, the Bridge is balanced. It means that the pointer of the galvanometer is at the zero position, when we close the circuit. And  $R_0$  is the value of the resistor of the resistance box taken out when the Bridge is balanced. The value of the resistor depends on the knobs taken out
- 762 To: Teacher, please check our circuit
- 763 Ti: Is this circuit set up correctly, sir?
- 764 In: This is the junction of the circuit. Start checking from the positive symbol, the plus terminal of the power is the plus one of the switch K ... the minus terminal of power supply is the minus one of the switch K. D is the junction of three branches, so this galvanometer ... Where is this point D connected to?
- 765 Ti: The formula of the resistor measured is  $R_b = R_0(L/L')$ .  $L'$  is here;  $L$  is here ... And  $R_0$  is here. Let's take out the knob indicating 4 ohms, all right?
- 766 Th: OK! ... Press the switch K

As seen in utterance 765, traditional laboratory is exercises with the replication of procedures and verification of laws, principles for adjusting their data correctly.

- 767 Ti: Insert the knob indicated 30 ohms, take out 20 ... Twist it. Take a pincer ...
- 768 Ng: Take this one away. Neglect it. Do not touch it
- 769 Ti: Take out more, insert the knob indicating 4 ohms
- 770 Ng: Ti, move the wire contact on LL' in order to see whether the pointer moving backward or not
- 771 Ti: Insert, insert the knob indicating 1 ohm. Take it out. Insert the 20 ... All right!
- 772 Ng: Push it to the other side of the wire. Move forward, and check whether it is moving or not move backward. It is easier to move backward ... Move back ... All right!
- 773 To: So ...
- 774 Ng: All right!
- 775 Ti: 32, 32 ... right?
- 776 To: How about the L?
- 777 Ti: 50.2 ...
- 778 Ng: Please notice that this one is R2
- 779 Ti: All right! ... How many for R2. This one is 32.2. Now, let's measure R1 ... Take out the knob indicating 40 ohm ... Do you insert it very tightly? Insert very tightly
- 780 Th: Yeah, all right
- 781 Ti: Take the knob indicating 10 ohm. Insert the 20
- 782 Ti: OK! Insert the knob indicating 20 ohm
- 783 Ti: Continue taking out, more. Insert the knob indicating 3 ohms. Take out the 1. Take out the 3 ohm knob. Insert the 1. Take out the 2 ohm knob. Insert the 1 ohm knob ... What? What is going on? Not yet ... Insert the former one

Traditional laboratory does not provide opportunities for students to make up the problems on their own interest, design their own experiments to search for new understandings about the phenomenon arose from the experimental tasks. As a result, students fail to deal with everyday problems in real-world practice for promoting authentic science.



- 784 Ti: OK! Let's check whether it is balanced or not
- 785 Th: Already ...  $R_0 = 12$  ohms
- 786 Ti:  $R_0 = 12$  ohms, right?
- 787 To:  $R_2$ ?
- 788 Ti: How many for  $R_2$ ?  $R_0 = 12$ , right?
- 789 Ng: How about the data you have got few moments ago, Ti?
- 790 Ti: 50.5
- 791 Ng: How about your conclusion? Which resistance is greater?
- 792 Ti: 50.5 divides by nearly 49
- 793 Ng: 49.5
- 794 Ti: It is multiplied by 12, right?
- 795 To: 12.2
- 796 Ti: 12.2. So, we have  $R_2$  is greater than  $R_1$
- 797 To: We have concluded that  $R_2 > R_1$ , all right! Now, through experimenting, we see that  $R_2$  is greater than  $R_1$
- 798 Ti: We conclude that  $R_2$  is greater than  $R_1$ ;  $R_1$  has the small size.  $R_2$  has the big size.  $R_1$  is ...  $R_1$  is 12.2 ohms;  $R_2$  is around 30, right? It equals to 32.2 ohms. So let's compare two results, and we conclude that it is correct,  $R_2 > R_1$  is absolutely right
- 799 Ng & Ti: Now, we consider the circuit in series
- 800 Ti: The circuit in series, the circuit has two resistors in series ...
- 801 To: Let's write these symbols in capitals
- 802 Th: Connect two resistors in series. They are added together, right?

- 803 Ti: This one is 12, and that one is 32 ...  
Here is 4, all right!
- 804 Ng: 44.4 ...
- 805 Ti: 44.4 ohms. Let's test whether it is 44.4  
ohms or not. In series. Please take out  
50
- 806 Ng: Try to press the switch K to check  
whether it is working or not
- 807 Ti: 50, 40, all right!
- 808 Ng & Ti: ... 50
- 809 Ti: In series, right?
- 810 Th: In series
- 811 Ti: Is it balanced?
- 812 Th: It is balanced
- 813 Th & Ti:  $R_0 = 50$ ,  $L = 50.5$ , 50 ...
- 814 Th: 50.4 ...
- 815 Ti: 50.5 , 50.5, 50.05 ...
- 816 To: Well, let's turn it over
- 817 Ti: Here is ...
- 818 To: Turn it over again
- 819 Th: 50.5, all right
- 820 Ti: 50.5. Yeah, exactly 50.5. That one is  
49.5, right? Therefore, how many ohms  
are the resistance of  $R_0$  multiplied by the  
ratio of  $(50.5/49.5)$ ? How many ohms  
are the resistance of  $R_0$ ? 50, 50. How  
much?
- 821 Ti: How about the real value?
- 822 Ti: Exactly? Around 51 and 52, or  
something around that. 51, right? 51.  
Now, let's measure the resistance of R  
again
- 823 Ti: Take out the 20. Insert the 30

- 824 Ng: Take out the 10. Insert the 20
- 825 Ti: Take out another 10. Insert the 20. Take out the 10. Insert the 20. Tightly, please
- 826 Ng: All right! Try to press it, OK!
- 827 Ti & Ng: Continue taking out the 3. Insert the 3. Take out the 2
- 828 Ng: All right! Let's adjust ...
- 829 Ti: Take out the 1. Insert the 1, OK! It is balanced already
- 830 Ti: How many ohms for  $R_1$ ?
- 831 Ng: 12
- 832 Ti: How about the value of  $\{(L/L') I_2\}$ ?
- 833 Ng: 50.7. 50.6
- 834 To: 50.7
- 835 To: 49.3
- 836 Ti: How much?
- 837 To: 13
- 838 Ng: ... around 12
- 839 Th: 13. 13
- 840 Ti: How much? 12, right?
- 841 Ng: 12.3, 12.3
- 842 Ti: Last time it is 12.2. Now 12.3, all right! Have we measured another ones,  $R_1$ ,  $R_2$  yet?
- 843 Ti: The 30
- 844 Ng: The 40, OK!
- 845 Ti: All right, 40, OK! More, insert the 40. Take out the 30. Insert the 30 Take out the 20
- 846 (Pause)

- 847 Ti: ...5?
- 848 Ng: Yeah, take out
- 849 Ti: More, take out the 10. More ...
- 850 Ng: Yeah
- 851 Ti: Take out the 3, is it tight? Insert 2 ...  
insert that. Take out the 3, surely tight,  
OK? It is balanced, right? All right!
- 852 Th: 33
- 853 Ti: ... How many? ...
- 854 Th: 33
- 855 Th: 33. Read please. How many?
- 856 Ng: 50.4
- 857 Ti: 50.4
- 858 To: 49.6
- 859 Ti: 49.6. How many? 34, right?
- 860 Th: 33
- 861 To & Ng: 33.5
- 862 Ti: 33.5
- 863 To & Ng: So, we have  $R_2 > R_1$ . Exactly  
corresponds to the conclusion:  $R_2 > R_1$ .  
 $R_1$  has the small size, right? All right!  
We have finished indicating one thing
- 864 Ti: Have we measured the resistors in series  
yet?  $R_2 = 45.8, 45.8$ . Last time we get  
50, 40
- 865 Ng: 40 is all right
- 866 Ti: ... and how many more? It is wrong.  
Take out another 10. More ... more ...  
more, all right! Insert the 10
- 867 Ng: Insert that one. More and more ...
- 868 Ti: How about the total ohms? 44, right?

869 Ng: Move the key contact in order to check whether the pointer of the galvanometer changes its direction a lot or not

870 Ti: Yeah, it changes

871 Ng: So, do we have to insert more or take out more?

872 Ti: All right! It is balanced

873 Th: 49

874 Ti: How many?

875 Th: 49

876 Ti:  $R_0 = 49$ , right? 49. Therefore, it is ...  
( $R_1 + R_2$ )

877 Ng:  $R_1 = 47.3$

878 Ti: 47.3, 47.3. How many for that one?  
How about the division?

879 Ng: 52.7

880 Ti: 52.7, right? How many?

881 To: 43.9, right? ... Nearly 43.9

882 Ti: 43.9

883 Ti: 43.9. Therefore, they are nearly equal to each other

884 To: Nearly, because we may not twist tightly the ...

885 Ti & Th: According to the addition of two resistors in series ... After experimenting, it changes around 43 to 45. We see that they change around 44 to 45

886 In: Because you did not twist it tightly, you have to insert and twist it tightly. The result will be exactly correct

887 Ti: So, the result is nearly the same ... How about in parallel? How about the formula of two resistors in parallel?  $(1/R) = (1/R_1) + (1/R_2)$ . How about its value in parallel?

888 Ng: Let's measure it

889 Ti: How about the approximate value?

890 Th: ... 8.9 nearly 9 ohms

891 Ti: 9 ohms, right? Now, take out the 10. Insert tightly. Insert very tightly those knobs. Have you taken out the 10 knob? Take out the 10 ...

892 Ng: Take out the 8. Insert the 10

893 Ti: How do we know the value is around 8 ohms? Take out more. Insert ...

894 Ng & Ti: Insert and take out the 1 ohm knob

895 To: Twist tightly

896 Ti: All are tight, right?

897 Th: All right!

898 Ti: All right! It is balanced

899 Th: 8

900 Ti: How about the  $R_0$ ? 8, right?

901 To: 8

902 Ti: 4. Ng, please read how many?

903 To: 49 is exactly

904 Ng & Ti: 49 over 51

905 Ti: 8 ...

906 Ng: 7

907 Ti: Take out another 2 ohm knob. Insert the 1. Insert ...

- 908 Ng: Let it deflect toward here. Unsuccessful. Pull back. The same as before. Twist those knobs very tightly
- 909 Ti: All right! It is balanced. How many?
- 910 Th: 7, 9
- 911 Ng: It vibrates. If we do not twist the knob tightly, it vibrates. Do you see? right?
- 912 Ti: All right! How many? 9. 9 multiplies by 45, right? How much? 45, right?
- 913 To: 47
- 914 Ti: 47 over 53 or ... How many?
- 915 Ng & Ti: 8
- 916 Ti: It is exactly correct
- 917 In: Have you finished experimenting circuits in series and parallel?
- 918 Ti: We have finished already
- 919 In: Now, prepare to write your lab report, please
- 920 Ti: Report, teacher?
- 921 In: Yeah
- 922 Ti: May we hand it in tomorrow, sir?
- 923 In: OK! Then, please put in order instruments. Turn off the power supply. Take out the electrical plug from the AC power.

This utterance reveals that students concern on the right data. As a physics student and a physics instructor, the researcher recognizes that students often complete this "Wheatstone Bridge" experiment without knowing the meaning of their action, and without understanding the science concepts used in the experimental tasks. To students, the purpose of undertaking this experiment is to have the good marks according to the correct data given by the lab instructor.