

**ESTIMATING METABOLIC COSTS OF PYRENE EXPOSURE
USING WHOLE ANIMAL RESPIROMETRY**

by

Ann Hui Chuan Lee
B.Sc., Simon Fraser University

RESEARCH PROJECT
SUBMITTED IN PARTIAL FULFILLMENT OF
THE REQUIREMENTS FOR THE DEGREE OF
MASTER OF ENVIRONMENTAL TOXICOLOGY

In the Department
of
Biological Sciences

© Ann Hui Chuan Lee, 2004
SIMON FRASER UNIVERSITY
Fall 2004

All rights reserved. This work may not be
reproduced in whole or in part, by photocopy
or other means, without permission of the author.

APPROVAL

Name: Ann Hui-Chuan Lee

Degree: Master of Environmental Toxicology

Title of Project:

Estimating metabolic costs of pyrene exposure using whole animal respirometry

Examining Committee:

Chair: Dr. R.W. Mathewes

Dr. C.J. Kennedy, Associate Professor, Senior Supervisor
Department of Biological Sciences, S.F.U.

Dr. R.A. Nicholson, Associate Professor
Department of Biological Sciences, S.F.U.

Dr. F.C.P. Law, Professor
Department of Biological Sciences, S.F.U.
Public Examiner

December 9th, 2004
Date Approved

SIMON FRASER UNIVERSITY



PARTIAL COPYRIGHT LICENCE

The author, whose copyright is declared on the title page of this work, has granted to Simon Fraser University the right to lend this thesis, project or extended essay to users of the Simon Fraser University Library, and to make partial or single copies only for such users or in response to a request from the library of any other university, or other educational institution, on its own behalf or for one of its users.

The author has further granted permission to Simon Fraser University to keep or make a digital copy for use in its circulating collection.

The author has further agreed that permission for multiple copying of this work for scholarly purposes may be granted by either the author or the Dean of Graduate Studies.

It is understood that copying or publication of this work for financial gain shall not be allowed without the author's written permission.

Permission for public performance, or limited permission for private scholarly use, of any multimedia materials forming part of this work, may have been granted by the author. This information may be found on the separately catalogued multimedia material and in the signed Partial Copyright Licence.

The original Partial Copyright Licence attesting to these terms, and signed by this author, may be found in the original bound copy of this work, retained in the Simon Fraser University Archive.

W. A. C. Bennett Library
Simon Fraser University
Burnaby, BC, Canada

ABSTRACT

This project quantified the energetic costs of pyrene detoxification by measuring oxygen consumption rates in fish exposed for either 3 or 15 days in a flow-through respirometer. Biliary 1-OH pyrene was analyzed at the end of the short-term experiment in an attempt to correlate biotransformation with oxygen consumption. No concentration-response relationship was detected in resting routine metabolic rate (RRMR), routine metabolic rate (RMR), or activity-dependent metabolic rate (ADMR) in the short-term experiment. Biliary 1-OH pyrene concentrations were significantly different ($p < 0.05$) between the 0 mg/L, 0.01 mg/L, and 0.05 mg/L treatment groups. No significant difference was detected between 0.05 mg/L and 0.10 mg/L treatment groups. In the long-term experiment, the control and 0.1 mg/L treatment groups did not differ in RMR and ADMR. A small but significant increase ($p < 0.05$) was detected in RRMR with pyrene exposure, suggesting that the energetic costs of pyrene detoxification in juvenile trout may be relatively low.

DEDICATION

I would like to dedicate my work to God. He has given me strength to overcome various difficulties I encountered in this project and life.

ACKNOWLEDGEMENTS

Many people have given me much support in completing the M.E.T. program. First of all, I would like to thank my supervisor, Dr. Christopher J. Kennedy for his valuable support and guidance. It has been a great learning journey in various aspects while working with Dr. Kennedy.

I would also want to thank Dr. Russell A. Nicholson for providing me valuable advice and allowing me to use the Perkin-Elmer LS 50 fluorescence spectrophotometer in his lab.

A special word of thanks goes to Devika Jayawera for showing me how to operate the respirometer and solve various respirometer problems. I would like to thank Onkar Bains for showing me how to use the Perkin-Elmer LS 50 fluorescence spectrophotometer. I would also like to thank Bruce Leighton for ordering trout for my project, setting up the tanks needed to house the trout and giving me advice on how to house trout.

My sincere thanks go to my family, friends, and colleagues of the M.E.T program and the Kennedy lab, all of whom have encouraged me throughout the difficult times.

TABLE OF CONTENTS

Approval.....	ii
Abstract.....	iii
Dedication.....	iv
Acknowledgement.....	v
Table of Contents.....	vi
List of Figures.....	vii
List of Table.....	viii
List of Abbreviation and Acronyms.....	ix
Introduction.....	1
Material and Methods.....	13
Results.....	23
Discussion.....	49
Conclusion.....	59
References.....	62

LIST OF FIGURES

Figure 1.	The chemical structure of pyrene.....	12
Figure 2.	A schematic diagram of the intermittent flow through respirometer system used to measure routine oxygen consumption.....	17
Figure 3.	Oxygen concentration pattern in respirometer vessels housing rainbow trout during first three cycles of the pre-exposure period	25
Figure 4.	Oxygen consumption rates of control juvenile rainbow trout in a vessel during the 48-h pre-exposure and 72-h pyrene exposure periods	27
Figure 5.	Daily mean oxygen consumption rates of juvenile rainbow trout during the 48-h pre-exposure and 72-h pyrene exposure periods	29
Figure 6.	An example of oxygen consumption rates of control juvenile rainbow trout in a vessel during 24-h feeding and 24-h cleaning periods.....	35
Figure 7.	Daily mean oxygen consumption rates of juvenile rainbow trout during the 48-h pre-exposure and the 15-d pyrene exposure periods	37
Figure 8.	ADMR, RRMR, and RMR of rainbow trout during a 15-d of 0 mg/L and 0.1 mg/L pyrene exposures.....	39
Figure 9.	Typical SFS spectra for several 1-OH pyrene concentrations.....	43
Figure 10.	Standard curve constructed from net peak area of standard solutions of free 1-OH pyrene	45
Figure 11.	Biliary 1-OH pyrene extracted from the gall bladders of juvenile rainbow trout after exposure to 0, 0.01, 0.05, and 0.1 mg/L pyrene for 72 hours	47

LIST OF TABLES

Table 1.	Summary results of RRMR, ADMR, and RMR determined in short term experiment	31
Table 2.	Percent decreases in RRMR, ADMR, and RMR calculated from the differences between the mean pre-exposure and exposure metabolic rates in the short-term experiment	32
Table 3.	Literature values of RMR of salmonoids	61

LIST OF ABBREVIATIONS AND ACRONYMS

°C	Degree Celsius
1-OH	1-hydroxy
1-OHPG	1-hydroxy pyrene glucuronide
ADMR	Activity-dependent metabolic rate
AMR	Active metabolic rate
d	Day
g	Gram
g	Gram
h	Hour
H ₂ O	Water
L	Litre
m	Meter
min	Minute
MS-222	Tricaine methanesulfonate
PAH	Polycyclic aromatic hydrocarbon
RMR	Routine metabolic rate
RRMR	Resting routine metabolic rate
SFS	Synchronous fluorescence spectrometry
SMR	Standard metabolic rate
v/v	Volume to volume

Prefixes for units of measurement

n	nano
μ	micro
c	centi
m	milli
k	kilo

INTRODUCTION

Bioenergetics and Detoxification

All organisms need energy for their survival. Energy assimilation, transformation, loss and use in animals are the main focuses of bioenergetics. The basic tenet of bioenergetics is a balanced energy budget with respect to energy assimilated, energy lost and energy used for biological processes. This balance can be represented by a general bioenergetic equation for animals:

$$R = E + P + M \quad (1)$$

where R is ingested energy, E is lost energy in excretion, P is energy used for production, and M is the energy used for metabolism (Jobling, 1993). The energy used for production can be further subdivided into reproduction and growth (Adams and Breck, 1990). Every component of the bioenergetic equation is the sum of energy used for the various biochemical and physiological processes of each component.

Generally, animals have relatively fixed energy budgets (Maryanski *et al*, 2002). All animals have limits on the amount of energy they can assimilate, and if two processes compete directly for this limited amount of energy, an increase in energy allocation to one process will result in a decrease to another, according to the principle of energy allocation (Kitchell 1983). In order to understand the prioritization of various bioenergetic components, energetic costs and tradeoffs for various bioenergetic components need to be examined. The degree to which organisms allocate their energy depends on the energy available and the energy

demand for each component (Sandland and Minchella, 2003; Lardner and Loman, 2003). Hence, energetic costs of various components and activities have been demonstrated in numerous studies associated with swimming, reproduction, immune responses, and growth in order to gain a better understanding of energy budgets and its allocation. In fish, an extensive literature exists on the energetic costs of swimming and reproduction, however, little information exists on the costs of defence mechanisms in fish, such as the immune system and xenobiotic processing.

The energetic costs associated with immune responses have been examined in several species. For example, Demas *et al.* (1997) examined the effect of an immune response on energy balance by injecting keyhole limpet hemocyanin (KLH) into C57BL/6J mice. KLH-injected mice exhibited increased immunoglobulin G responses and oxygen consumption compared to saline-injected mice. Moreover, they found that older mice were not able to maintain sufficient heat production despite comparable oxygen consumption to younger mice. A study by Derting and Compton (2003) demonstrated that wild white-footed mice (*Peromyscus leucopus*) injected with sheep redblood cells (SRBC) had significantly smaller dry masses of small intestine and testes compared with control mice, however, mice whose immune systems were suppressed by cyclophosphamide did not show any effect on metabolic rates or organ masses. Therefore, it was concluded that the energetic costs of mounting an immune response could be met through reductions in energy allocation to growth in other physiological systems. Henken and Brandsma (1982) performed a similar

immune response study on chickens and found that SRBC-injected chickens consumed more food but gained less weight than saline-injected control chickens. In that study, the increased energetic costs of mounting an immune response were supplied by an increase in energy intake.

Energetic costs associated with xenobiotic exposure have also been examined in variety of studies. A study by Maryanski *et al.* (2002) showed that the body caloric value and morphological status of carabid beetles (*Poecillus cupreus L.*) were reduced significantly after feeding cadmium or zinc-contaminated housefly pupae. Growth rates of fathead minnow (*Pimephales promelas*) were significantly reduced when fed with selenium-spiked diets (Ogle and Knight, 1989). Weber (1996) found that lead-exposed juvenile fathead minnows increased daily fecal production and showed reduced weight gain compared to control fish. The results of these studies suggested that the energetic costs of xenobiotic exposure are incurred through the consequences of detoxification, excretion, maintenance of homeostasis, and repair of damage due to toxic effects of the compounds.

The primary focus of this research project was to determine the energetic costs of xenobiotic detoxification and processing without the complicating factor of toxic effects. Limited research on this aspect of xenobiotic exposure exists. Most published studies have mainly focused on host plant specialization in insects and in vertebrate foraging behaviour. Food preference in herbivorous insects is believed to be related to the effects of secondary metabolites in host plants. At sub-lethal levels, plant secondary metabolites can demand significant

nutritional costs to herbivores by affecting nutrient utilization (Lindroth and Batzli, 1983; Robbin *et al*, 1987; Robbins *et al.*, 1991), or by increasing the energetic cost of detoxification post absorption (Dash, 1988). Efforts to quantify the direct costs of plant allelochemical detoxification have for the most part proven equivocal since the measurements of metabolic costs are confounded with toxicological impacts. The xenobiotics may inhibit feeding and reduce the digestive efficiency of food, hence, the effects detected may be due to reduced total energy assimilation. Similar difficulties also exist in fish studies to date. Xenobiotic exposure can also impact the growth and reproduction of fish (Helder, 1981; Krisfalusi *et al.*, 1998; Mondon, 2001; Vetemaa, 1997). However, it is often difficult to determine whether reductions in reproduction or growth are the result of energy allocation from growth or if growth reduction was caused by toxicological impacts (for example, physiological stress, repair of damaged systems, reduced assimilation efficiency, suppressed appetite) or a combination of both (Beyers, 1999a, 1999b).

The questions of whether the energetic costs of xenobiotic detoxification are substantial, detectable, and quantifiable are now beginning to be answered. A study done by Cresswell *et al.* (1992) was the first to demonstrate that detoxification imposed a significant metabolic load in the southern armyworm, *Spodoptera eridania* after exposure to sub-lethal levels of nicotine (0.5 % in the diet). Sub-lethal dietary nicotine exposure resulted in an increase in the allocation of assimilated food to energy metabolism and reduced net growth efficiency. This effect was not related to any decrease in the amount of food

digested. In another study, the energetic costs used in maintaining high and inducible levels of cytochrome P450-mediated xanthotoxin metabolism resulted in reduced growth in the parsnip webworm, *Depressaria pastinacella* (Berenbaum and Zangerl, 1994). Many recent studies have directly measured metabolite excretion and the associated energy losses in birds (Guglielmo *et al.*, 1996), mammals (Lindroth and Batzli, 1984), and marsupials, (Dash 1988; Foley, 1992). For example, the detoxification of coniferyl benzoate assimilated from the diet resulted in an estimated energetic cost of 10 to 14% of metabolizable energy intake in ruffed grouse (*Bonasa umbellus*) (Guglielmo and Karasov, 1996).

The costs of xenobiotic detoxification may be related to increases in energy used in enzymatic reactions, maintenance of acid-base balance modified by the production of the acidic metabolites and nutrient drains from conjugation reactions with endogenous substrates (Foley, 1992). It has been suggested that the biosynthetic energetic costs of producing and maintaining a high level of detoxification enzymes might also constitute a significant component of the energy budget of an organism smaller than a rodent (Brattsen, 1979; Brattsen, 1988).

Respirometry

Two basic methods for measuring metabolic rate are direct and indirect calorimetry. Direct calorimetry measures the heat production or energy content. For example, direct calorimetry can be used to measure the calorific content of samples of food, solid faeces, flesh, and gametes by burning dried material in an

oxygen atmosphere in a bomb calorimeter (Wootton, 1990). However, metabolic heat generated by fish is seldom measured by direct calorimetry because of low heat production rates in fish and the high heat capacity of water. Indirect calorimetry measures either carbon dioxide production or oxygen consumption. Carbon dioxide production is more difficult to measure than oxygen consumption in aquatic systems because the high solubility of carbon dioxide makes it difficult to measure the partial pressure of carbon dioxide accurately with an electrode (Cech, 1990). Moreover, carbon dioxide can be transformed to carbonates and bicarbonates in hard water (Burggren, 1979). Therefore, oxygen consumption rate has become the conventional method for metabolic rate measurement because oxygen concentration can be measured more easily and accurately (Cech, 1990; Wootton, 1990). Respirometry is one method to quantitatively measure energy consumption rates (Cech, 1990).

Oxygen consumption rates as an indirect measurement of metabolism are only accurate when anaerobic contributions are insignificant. When oxygen consumption in fish does not meet metabolic requirements during conditions such as high speed swimming and/or exposure to extreme hypoxia, substantial anaerobic respiration is induced to supply energy. Anaerobic respiration allows energy production in the absence of oxygen, hence, the oxygen consumption rate is not indicative of the energy produced through total respiration. In the present study, the contribution of anaerobic metabolism to energy use was considered to be negligible because no extreme activity or hypoxic conditions were part of the experimental design.

Aerobic metabolism in fish can be categorized as standard, resting routine, routine, activity dependent, and active. Fry (1957) introduced standardized terminology for describing metabolic rates in fish. Standard metabolic rate (SMR) is the minimum rate of energy usage necessary to keep a fasting organism alive when completely free of any movement. Since locomotor activity cannot be totally eliminated in fish, SMR is difficult to measure. Resting routine metabolic rate (RRMR) is a more useful term that describes the metabolic rate for quiescent fish (Cech, 1990). Routine metabolic rate (RMR) refers to the mean rate of energy used during routine activity, with precautions taken against any influences from external stimuli. RMR reflects the normal level of spontaneous movement. Occasionally, fish will swim at higher speeds than found in normal activity; therefore, the activity-dependent metabolic rate (ADMR) is a better descriptor for energetic costs under these circumstances than RMR (Rice *et al.*, 1983). Active metabolic rate (AMR) is the maximum metabolic rate when an animal sustains a very high level of activity. It can also be considered as the maximum aerobic rate needed for sustainable maximum swimming velocity. The above classification of metabolic rate is modified from the categorization and definitions used by Cech (1990).

Studies which express the oxygen consumption rate as RMR typically place fish in closed free-swimming chambers and measure the rate of oxygen depletion in the chamber over a period of time. Since SMR is the minimum rate required to sustain life, it should be measured when fish are absolutely quiescent without energy spent on activity, food digestion, reproductive development,

growth or stress responses (Cech, 1990). Hence, innate restlessness of pelagic fish makes the determination of SMR difficult in free-swimming chambers. Studies expressing oxygen consumption rates as SMR generally use demersal or sedentary fish in free-swimming respirometers and active fish in a swim tunnel. In order to determine SMR using a swim tunnel, a relationship between swimming speed and metabolic rate of fish is first established. The metabolic rate is then extrapolated to the zero swimming velocity, thus estimating SMR (Jobling, 1993). This method is useful for examining the minimal metabolism of active species which rarely remain quiescent. Since rainbow trout used in this experiment are pelagic fish with moderate activity, the overall metabolic rates determined from oxygen consumption were considered as RMR. The overall metabolic rates measured in this study were further differentiated into RRMR and ADMR depending on the pattern and level of oxygen consumption.

The focus of respirometry applications in the aquatic environment have evolved ever since the publication of Winkler's method for the determination of dissolved oxygen in water (Winkler cited in Beamish, 1964). The earliest respirometry studies date before the 1960s and were used to examine the relationship between oxygen consumption and fish activity (Beamish and Mookherjee, 1964a; Beamish and Mookherjee, 1964b). In the 1960s and 1970s, respirometry studies focused on the effects of attributes such as fish weight, and environmental factors such as temperature on metabolic rates (Beamish, 1964; Beamish and Mookherjee, 1964a; Beamish and Mookherjee, 1964b; Caulton, 1978). Several recent studies have begun to examine the effect of xenobiotic exposure

on metabolic rates in fish (Johansen and Geen, 1990; Mackinnon and Farrell, 1993; Yang and Randall, 1997; Beyer, 1999b; Jayaweera, 2002; Cheng, 2003). However, no studies have been performed to assess the costs of xenobiotic exposure through this technique.

Polycyclic Aromatic Hydrocarbons (PAHs) and Pyrene

Polycyclic aromatic hydrocarbons are a class of xenobiotic chemicals consisting of two or more fused benzene rings in various arrangements. Hundreds of PAHs have been identified by the number of fused rings and the number and placement of substitutions on the aromatic rings. PAH molecular weights range from 128.6 for naphthalene to 300.36 for coronene (Kennedy, 1990).

PAHs are common pollutants present in surface water, soil, air and sediment (NRCC, 1983). Most PAHs are released into the environment as a result of the incomplete combustion of organic matter and from petrochemical pollution (Hase and Hites, 1978). Human activities are the primary cause of PAHs entering the aquatic environment, for example, through petroleum spillage, domestic or industrial wastes discharges, and surface runoff (Arfsten *et al.*, 1996; Law *et al.*, 1994). PAHs tend to accumulate in sediments in high concentrations because of their lipophilic and hydrophobic nature (NRCC, 1983). Surface waters may contain traces of measurable concentrations of PAH, and the majority of PAHs in the water column are adsorbed to suspended organic

particulates. Typical PAH concentrations in sediment are approximately 1000 X higher than in overlying water (Lin *et al.*, 1994). Although most PAHs degrade rapidly under aerobic conditions, PAHs may persist for long periods in oxygen-poor environments (Arfsten, 1996). Photolysis is a major degradation pathway for PAHs in the environment because PAHs are particularly sensitive to UV radiation.

Pyrene (Figure 1) was selected as a model xenobiotic because of its extensive and rapid of metabolism in fish via phase I and II reactions, and because no measurable toxic effects at relative high concentrations have been shown (Kennedy, 1990). Law and Kennedy (1991) determined that pyrene was metabolized rapidly following an intraarterial administration. The low toxicity of pyrene (Nisbet and LaGoy, 1992) in fish is necessary to avoid the confounding effects on metabolic rate measurements.

1-hydroxypyrene (1-OH pyrene) and its conjugates are the major metabolites of various PAHs and is the primary metabolite of pyrene (Ariese *et al.*, 1993; Law *et al.*, 1994; Stroomberg, *et al.*, 1999; Ruddock *et al.*, 2002). Various studies examining PAH exposure have reported 1-OH pyrene to be a useful biomarker of PAH exposure (Levin, 1995; Lee *et al.*, 1999). Moreover, biliary 1-OH pyrene concentrations are correlated with the degree of PAH pollution in the environment (Krahn *et al.*, 1987; Ariese, *et al.*, 1993). Biliary 1-OH pyrene usually exists as a glucuronide conjugate and is seldom detected in the non-conjugated form (Law *et al.*, 1994; Namdari, 1998). When bile is analyzed using high performance liquid chromatography (HPLC), the conjugates are

hydrolysed by addition of enzymes such as β -glucuronidase and arylsulfatase (Ariese *et al.*, 1993; Namdari, 1998). Synchronous fluorescence spectrometry (SFS) is a highly sensitive, rapid and cost efficient method in detecting 1-OH pyrene (Ariese, *et al.*, 1993; Lin *et al.*, 1994; Stroomberg *et al.*, 1996). Ariese *et al.* (1993) suggested that bile sample could be analyzed without hydrolysis because the coupling of glucuronic acid to the phenolic OH-group could be regarded as a minor negligible perturbation of the electronic system of the chromosphere.

Objectives of Study

The significance of the metabolic cost of detoxification in the overall energy budgets of fish is largely unknown. The purpose of this project was to quantify the energetic costs of pyrene detoxification by measuring oxygen consumption rates in fish exposed to the model PAH, pyrene. To accomplish this, groups of juvenile rainbow trout were placed in free swimming respirometer vessels and exposed to pyrene for 3 or 15 days. Oxygen consumption rate was measured through the exposure period and was correlated with measurements of pyrene metabolism.

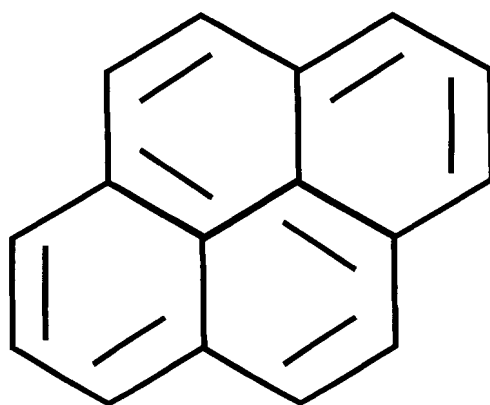

Figure 1. The chemical structure of pyrene.

MATERIAL AND METHODS

Experimental animals

Rainbow trout (*Oncorhynchus mykiss*) of both sexes, weighing 7.3 ± 1.4 g were obtained from Sun Valley Trout Farms (Mission, BC). Fish were housed in 750-L fibreglass holding tanks and acclimated under a 12 h light: 12 h dark photoperiod at 10 to 14°C in flowing dechlorinated municipal water. Dawn and dusk began at 8:00 am and 20:00 pm, respectively. Water hardness was 6.7 ± 0.1 mg CaCO₃/L, and pH was 6.7 ± 0.1 . During acclimation, fish were fed with trout starter feed (Nutra Plus, Crumb #2).

Chemicals

Pyrene and 1-hydroxypyrene (1-OH pyrene) were purchased from Aldrich Chemical Co. (Milwaukee, WI). Polyoxyethylene sorbitan monolaurate (Tween 20) and sodium citrate were purchased from Sigma Chemical Co. (St. Louis, MO). Anhydrous ethanol was obtained from Commercial Alcoholics Inc. (Brampton, ON). Tricaine methanesulfonate (MS-222) was purchased from Argent Chemical Laboratory (Redmond, WA).

Respirometer

The set up of the respirometer for this project was based on the design by Duval *et al.* (1981). An eight-vessel, computer controlled, intermittent flow respirometer was used to expose fish to pyrene and to measure oxygen consumption (Figure 2). A central computer control system was used to set the purging period, toxin concentration in each vessel, and oxygen concentration recording frequency. The volume of the glass respirometer vessels was 9.3 ± 0.2 L. Each set of four respirometer vessels were housed in a Plexi-glass water bath. Municipal dechlorinated water was used to fill an overhead reservoir which contained aquarium floss for filtration and an overflow drainage tube. This reservoir maintained a continuous supply of water to the respirometer system and the two water baths which were used to maintain an appropriate and consistent water temperature in the respirometer vessels during an experiment.

Water in the overhead reservoir was sent through a central water distribution octopus, where water was diverted among nine computer controlled solenoid valves. Eight valves controlled the water flow to eight individual vessels, and one valve controlled water output during vessel by-pass purge time. The by-pass purge time was used to eliminate residual toxin in the octopus prior to the beginning of purging a new vessel. The purge time of each vessel and the height of the overhead reservoir determined the total volume of water purged through each vessel during each purge time. The purge rate was 1.65 L/min and purge time was 450 seconds. Therefore, the total volume of water replaced into each vessel was 12.4 L every two hours. This ensured that pyrene

concentrations were maintained at the desired concentration throughout the entire experiment. Nalgene tubing with 1.3 cm interior diameter was used for all water flow connections.

A 20 L glass bottle was used to contain the pyrene stock solution. Tween 20 (0.1mg/L) was used to dissolve pyrene in water because of pyrene's low water solubility. The concentration of pyrene in the stock solution was 10 mg/L. The pyrene stock solution was replaced every 4 hours. The stock solution was stirred with a magnetic stir bar throughout the experiment to ensure a homogenous suspension of pyrene. A computer-controlled peristaltic pump was used to administer the stock pyrene solution into the octopus. The toxin pump rate was set at 20 ml/min. The duration of the pump operation was computer controlled to provide the desired volume of stock solution to each vessel during purge time.

Each respirometer vessel contained one Point Four Oxyguard® dissolved oxygen probe (Point Four Systems, Richmond, B.C.) for measuring oxygen concentration. These oxygen probes contained built-in temperature compensation. Oxygen probes were calibrated for temperature and atmospheric pressure before each experiment trial. Probes were removed from water and dried before calibration. The probes were hung in free air and less than 2 cm above the surface of the water to ensure close to 100% humidity. The computer reads each probe in turn continually until the readings stabilized. At the end of probe reading process, the temperature of water was entered into the computer program to calculate the conversion factor for the probes for proper calibration.

A propeller mounted on the lid of each vessel was used to ensure the continuous mixing of water around the oxygen probe in order to prevent localized oxygen depletion by the oxygen probe. Filter meshes were placed at both ends of each vessel to prevent fish escaping from the vessels.

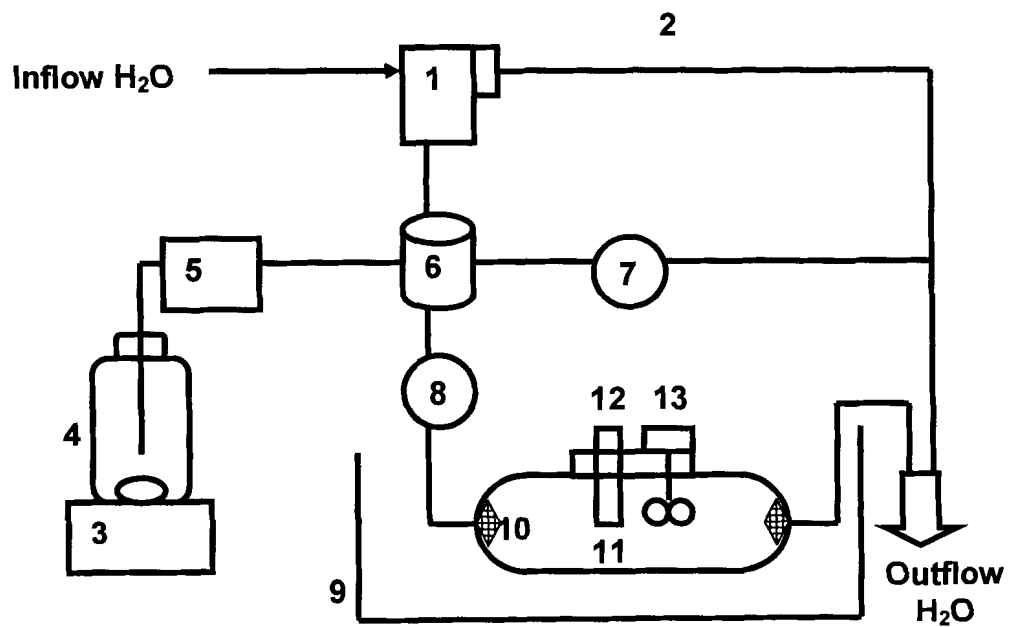

Figure 2. A schematic diagram of the intermittent flow through respirometer system used to measure routine oxygen consumption. 1. central reservoir, 2. overflow drainage tube, 3. magnetic stirrer, 4. toxin tank, 5. toxin pump, 6. distribution octopus, 7. outflow valve, 8. inflow valve, 9. water bath, 10. filter mesh, 11. respirometer vessel. 12. oxygen probe, 13. propeller assembly.

Experimental protocol for respirometry

All experiments were conducted under a 12 h light: 12 h dark photoperiod without dawn and dusk simulation. Fish were not fed for 24 hours before trials to ensure that fish were in a post-absorptive state. All experiments started at 12:00 pm to minimize effects of diurnal rhythms. Opaque polyethylene curtains skirted around water baths to minimize external disturbances. All water bubbles in the respirometer vessels were removed before starting each trial. The water bath and inflow water temperature was maintained at $13 \pm 1^{\circ}\text{C}$

Each cycle was 120 minutes. Water was purged through the by-pass valve for 60 seconds to remove residual chemical between vessel purges. Then, water was purged through each vessel for 450 seconds which completely replaced all the water in a vessel. Oxygen concentrations were measured and recorded every three minutes throughout the entire cycle.

Two experiments were conducted in this project. A short term experiment consisted of a 48-h pre-exposure period and a 72-h exposure period. Test concentrations of pyrene for the short term experiment were 0, 0.01, 0.05, and 0.1 mg/L. For each of two trials, two vessels were assigned to each concentration. Four fish were randomly placed in each vessel and acclimated to the vessels during the pre-exposure period without pyrene. Fish were exposed to pyrene for 72 h following the acclimation period. Daily visual observations of the respirometer system and fish health were performed during the light period.

At the end of the experiment, fish were sacrificed by an overdose of buffered MS 222 (100mg/L). Fish were blotted dry, weighed and dissected to

remove the gall bladder. Bile from each fish was removed and stored separately in a 1.5 ml microcentrifuge tube containing sodium citrate buffer (0.1 M, pH7.0) and stored at -80°C. Bile was later analyzed using synchronous fluorescence spectrometry (SFS) for the presence of 1-OH pyrene, the major biliary metabolite of pyrene in fish (Law *et al.*, 1994).

The long-term experiment consisted of a 48-h pre-exposure period and a 15-d exposure period. Two concentrations of pyrene were used for the long term experiment and were 0 and 0.10 mg/L. For each of two trials, three vessels were used for the 0 mg/L concentration, and four vessels were used for the 0.10 mg/L concentrations. Five fish were randomly placed into each respirometer vessel. Several preliminary experiments were not successful because fish were extremely stressed without feeding for a 17-d trial, and the mortality of control fish exceeded 10%. Therefore, in these subsequent experiments, fish were fed on the 5th and 11th days of the experimental period. Faeces and uneaten food were removed from the vessels on the 6th and 12th days of the experiment to prevent bacterial growth and the decomposition of uneaten food and faeces which could potentially affect the accuracy of oxygen consumption rate measurements. At the end of every trial, fish were sacrificed by an overdose of buffered MS222 and then weighed.

Pyrene metabolite analysis

Bile samples were thawed in a warm water bath briefly and then vortexed before dilution with ethanol/water (50:50 v/v). In order to obtain sufficiently

transparent samples and quantifiable peak intensity, the dilution factors ranged from 100 for control and 1×10^4 for the two highest pyrene concentrations. Metabolites in bile were measured by SFS according to a procedure modified from Ariese *et al.* (1993). All spectra were scanned in 1.5 ml quartz cuvettes (Fisher Scientific, Pittsburgh, PA) with Perkin-Elmer LS 50 fluorescence spectrophotometer (Perkin-Elmer Ltd., Beaconsfield, England). A spectral bandwidth of 5 nm was selected for both excitation and emission slits. SFS was measured in the range of 300-400 nm wavelengths with a constant wavelength difference of 37 nm. The areas underneath the fluorescence intensity traces were measured from 335-356 nm in order to quantify the amount of 1-OH pyrene and its conjugates. Since the peak intensity and the peak area under the curve of 1-OH pyrene glucuronide decreased by a factor of 2.2 after hydrolysis, the peak area determined in the non-hydrolyzed bile sample should be divided by this correction factor before determining free 1-OH pyrene concentration from the standard curve (Ariese *et al.*, 1993). The standard curve was constructed using free 1-OH pyrene solution because no commercial 1-OH glucuronide was available to prepare standard solution. Since the use of hydrolysis enzymes in the solution would cause considerable light scatter and interfere with the measurement, non-hydrolyzed bile sample was analysed. Moreover, only 4 percent of 1-OH pyrene exists as free 1-OH pyrene while the rest exists as conjugated 1-OH pyrene. The biliary 1-OH pyrene concentration will not be underestimated by applying the correction factor.

A standard curve was created using the areas underneath the fluorescence intensity traces obtained from a range of free 1-OH pyrene standard concentrations between 0.285 ng/ml and 5.8 nm/ml. A linear relationship between the area and 1-OH pyrene concentration was obtained from the standard curve using linear regression. The mathematic equation describing this linear relationship was then used to determine the actual concentration of 1-OH pyrene present in bile.

Data Analysis

Each 2-hour cycle consisted of 40 data points for oxygen consumption. Three data points were recorded during the purging period and thirty-seven points were recorded between purging periods. The oxygen concentration decreased gradually between purging periods as fish consumed oxygen. The change of oxygen concentration over time ($\Delta C_{O_2}/\Delta t$) for each cycle was estimated from the slope of the thirty-seven data points using the Microsoft® Excel linear regression analysis tool. Data recorded during the purging period were excluded from the linear regression. Oxygen consumption rate (R_{oc}) was based on a pooled value for multiple fish within a single respirometer vessel. R_{oc} was normalized to total fish mass ($\text{mg O}_2 \cdot \text{kg}^{-1} \cdot \text{h}^{-1}$) using equation 2:

$$R_{oc} = \Delta C_{O_2}/\Delta t \cdot V / M \quad (2)$$

where $\Delta C_{O_2}/\Delta t$ = the change of oxygen concentration over time ($\text{mg O}_2 \cdot \text{L}^{-1} \cdot \text{h}^{-1}$), V = volume of respirometer vessel (L), and M = fish mass (kg).

R_{oc} values were separated into three categories of metabolic rate: RRMR, ADMR, and RMR depending on the level of fish activity. For the short-term experiment, the differences in each category of metabolic rate among all experimental groups during both pre-exposure (without pyrene) and exposure periods (with pyrene) were compared using two-way analysis of variance (ANOVA) with a 95 % significance level in a single-factor randomized design (Samuels, 1989). The effect of pre-exposure and exposure period on RRMR and ADMR in each treatment group was compared using Student's paired t-test ($p < 0.05$). The concentration of biliary 1-OH pyrene in the different treatments was compared using ANOVA in a single factor randomized design. For the long-term experiment, the differences in each category of metabolic rate between the control and the 0.1 mg/L treatment group were compared using Student's t-test. All statistical analyses were performed using the JMP[®] IN 4.0.3 statistical analysis program (SAS Institute Inc., Cary, NC). Results were expressed as mean \pm SE.

RESULTS

Short-term experiment

In this experiment, fish were exposed to several concentrations of pyrene for 72 hours to determine its effect on whole animal respiration. Figure 3 shows a typical oxygen concentration pattern obtained from the oxygen concentration data during the first three cycles of the pre-exposure period. Oxygen concentrations declined linearly during non-purging periods as fish consumed oxygen and increased rapidly during purging periods as new water replenished the oxygen concentrations. Therefore, oxygen consumption rates were estimated from the data recorded during non-purging periods and excluded the data recorded during purging periods. An example of the oxygen consumption rate pattern of control juvenile rainbow trout during the short-term experiment is presented in Figure 4. Initial oxygen consumption rates were high and declined as fish recovered from handling stress and adjusted to the respirometer vessel during the first 6 hours of the pre-exposure period. Oxygen consumption rates increased when the photoperiod changed from dark phases to light phases and exhibited a characteristic circadian rhythm. Rates were generally higher during the light phases compared to dark phases, likely due to fish being more active during light phases. Calculations of mean of oxygen consumption within a day resulted in a large variability for the daily average oxygen consumption rates in all treatment groups (Figure 5). The daily average oxygen consumption rates

were high on day 1 but declined and stabilized after day 2. This observed trend was likely due to stress and acclimation to the test apparatus.

Oxygen consumption rates were subsequently differentiated into RRMR, ADMR, and RMR. RRMR was calculated from the means of the lowest oxygen consumption rates in the circadian rhythm. ADMR was calculated from the highest oxygen consumption rates in the circadian rhythm. RMR was calculated from the means of all oxygen consumption rates. Table 1 summarizes the mean values of RRMR, ADMR and RMR for all treatment groups during the pre-exposure and exposure periods. 95% confidence intervals (C.I.) were calculated for each mean metabolic rate using Student's t-test and ANOVA. Metabolic rates calculated for the pre-exposure period and the exposure period for each treatment group were compared using Student's t-test and were statistically different at $p < 0.05$. Mean metabolic rates decreased by 18.0 to 40.4% from pre-exposure to exposure periods (Table 2). The control group had the highest percent change in the mean metabolic rates while the 0.1 pyrene-exposed group had the lowest percent change in mean metabolic rate. From this result, it is speculated that control fish were able to recover from handling stress better than pyrene exposed fish. Further investigation is required to confirm this result.

No observable concentration-response relationship was detected for any of the three types of metabolic rates calculated during the exposure period (Table 1). From this, it is concluded that short-term pyrene exposure has no measurable effect on metabolic rate in juvenile trout at these concentrations.

Figure 3. Oxygen concentration changes in respirometer vessels housing rainbow trout during first three cycles of the pre-exposure period. One cycle consisted of 120 minutes and 40 data points. Circled data points were points recorded during the purging period and were excluded from the oxygen consumption rate calculation.

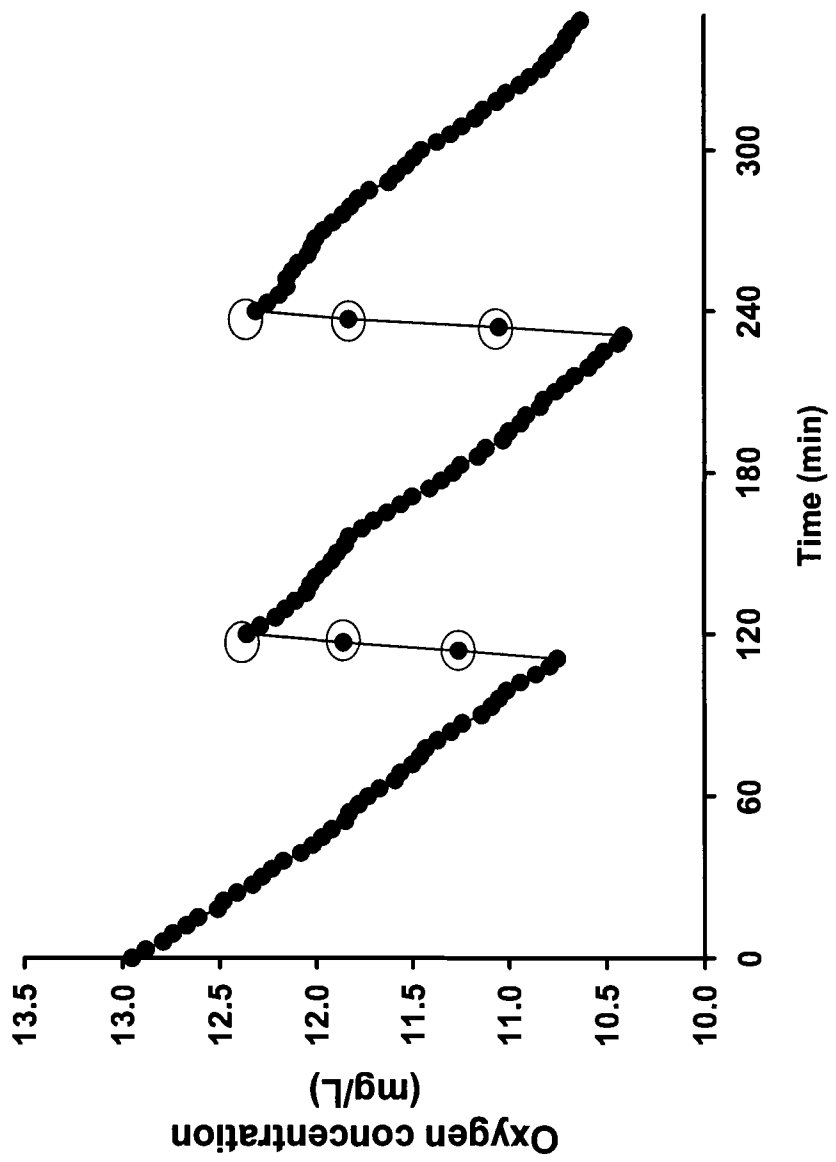

Figure 4. Oxygen consumption rates of control juvenile rainbow trout in a vessel during the 48-h pre-exposure and 72-h pyrene exposure periods. White bars at the bottom of the figure indicate the light phases of the photoperiod. Gray bars indicate the dark phases of the photoperiod. n = 4.

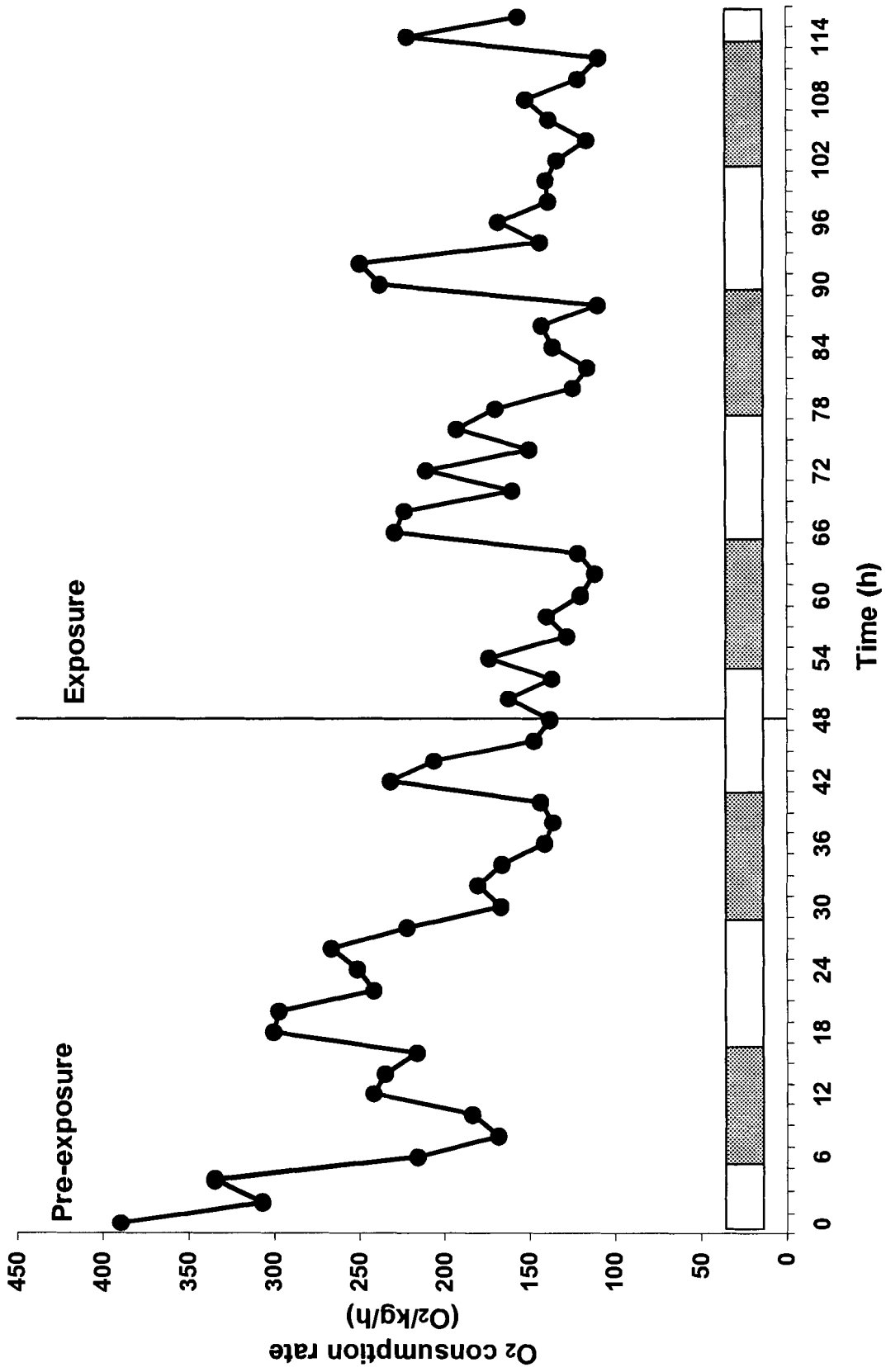

Figure 5. Daily mean oxygen consumption rates (mean \pm SE) of juvenile rainbow trout during the 48-h pre-exposure and 72-h pyrene exposure periods. Exposed pyrene concentrations were 0 mg/L (\bullet), 0.01 mg/L (\blacktriangle), 0.05 mg/L (\square), 0.1 mg/L (\circ) (n = 12).

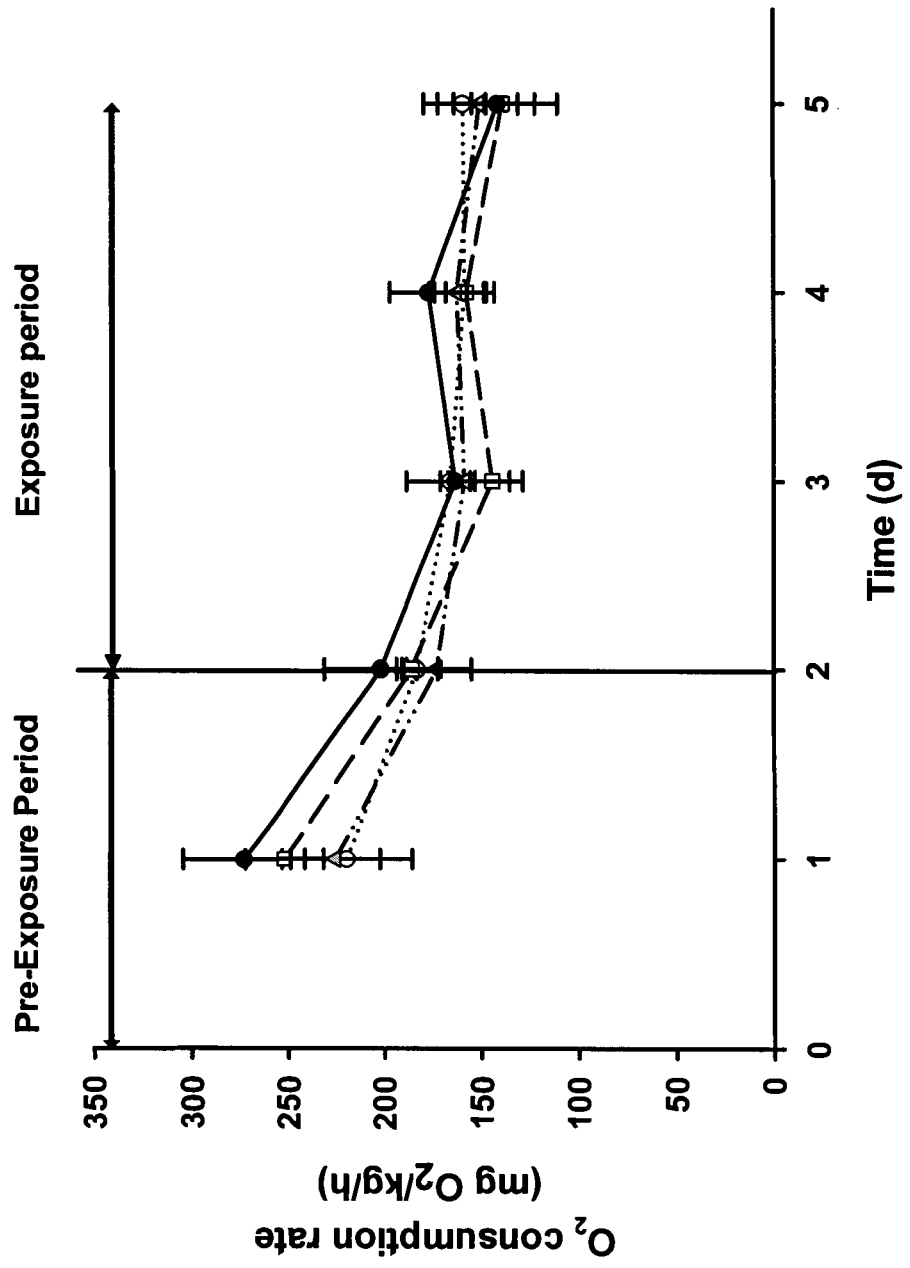

Table 1. Summary results of resting routine metabolic rates (RRMR), activity-dependent metabolic rates (ADMR) and routine metabolic rates (RMR) determined in the short term experiment. The blue numbers are the 95% C.I. calculated using student's t-test when metabolic rates of pre-exposure and exposure periods within a treatment were compared. The red numbers are the 95% C.I. of calculated using ANOVA when the pre-exposure or exposure periods among all treatments were compared.

Pyrene concentration (mg/L)	RRMR (mg O ₂ /kg/h) ± 95% C.I.		ADMR (mg O ₂ /kg/h)± 95% C.I.		RMR (mg O ₂ /kg/h)± 95% C.I.	
	Pre-exposure	Exposure	Pre-exposure	Exposure	Pre-exposure	Exposure
0	177.82 (164.27-191.37) (166.41-189.23)	127.97 (121.99-131.27) (120.44-135.50)	281.08 (255.73-306.42) (260.27- 301.88)	200.16 (118.45-211.87) (188.45-211.87)	226.99 (205.98-248.00) (209.09-244.89)	167.16 (155.01-179.5) (156.83-177.48)
0.01	166.75 (156.95-176.54) (156.25-177.24)	127.39 (121.99-131.27) (119.86-134.92)	260.05 (231.91-288.18) (236.02-287.07)	196.07 (186.65-205.49) (185.07-207.07)	200.88 (180.2-218.45) (182.76-219.00)	164.22 (154.42-174.40) (153.82-174.62)
0.05	168.18 (158.49-177.88) (157.69-178.68)	126.35 (144.20-165.31) (119.78-132.92)	262.37 (243.91-280.84) (238.35-286.39)	197.37 (182.30-212.44) (184.72-210.02)	202.64 (185.71-220.06) (84.53-220.76)	154.76 (144.20-165.31) (144.43-165.08)
0.1	162.89 (152.17-173.6) (152.18-173.59)	137.18 (132.28-142.08) (129.65-144.71)	248.72 (232.87-264.56) (226.15-271.28)	193.11 (182.76-203.47) (182.26-203.97)	197.63 (181.88-213.37) (179.73-215.53)	167.54 (158.63-176.46) (157.22-177.87)

Table 2. Percent decreases in RRMR, ADMR, and RMR calculated from the differences between the mean pre-exposure and exposure metabolic rates in the short-term experiment.

Pyrene concentration (mg/L)	RRMR	ADMR	RMR
0	39.0	40.4	35.8
0.01	30.9	32.6	22.3
0.05	33.1	32.9	30.9
0.10	18.7	28.8	18.0

Long-term experiment

In this experiment, fish were exposed to two treatments, 0 and 0.1 mg/L pyrene, for 15 days to determine the effects of long-term pyrene exposure on whole organism respiration. Fish were fed twice in the long term experiment in order to provide sufficient energy for survival. Oxygen consumption rates of rainbow trout increased during the two feeding and cleaning periods likely due to the costs of nutrient assimilation and the stress associated with external stimuli. Figure 6 shows an example of elevated oxygen consumption rate pattern in control fish during the feeding and cleaning periods. With the exception of the feeding and cleaning periods, oxygen concentration and consumption rate patterns in the long-term experiment were similar to those in the short-term experiment (Figure 3 and 4). The average daily oxygen consumption rates for the long-term experiment are shown in Figure 7. As in the short-term experiment, oxygen consumption rates were high at the beginning of pre-exposure period, declined and then levelled off as fish were acclimated to test conditions. A characteristic circadian rhythm was also observed in the long-term experiment.

Figure 8 shows the mean values for RRMR, ADMR and RMR in the 0 mg/L and 0.1 mg/L pyrene groups during the exposure period. Metabolic rates of fish in the two treatment groups were compared using Student's t-test. Neither ADMR nor RMR of the control and the pyrene-exposed fish were significantly different ($p > 0.05$). The RRMR in the control group was significantly lower than

the RRMR in the 0.1 mg/L group during the exposure period ($p < 0.05$). Therefore, there was small effect of pyrene exposure on RRMR, with an increase of 5 % in metabolic rate after 15 days of exposure.

Figure 6. An example of oxygen consumption rates of control juvenile rainbow trout in a vessel during 24-h feeding and 24-h cleaning periods. White bars at the bottom of the figure indicates the light phase of the photoperiod. Gray bars indicates the dark phase of the photoperiod (n = 5).

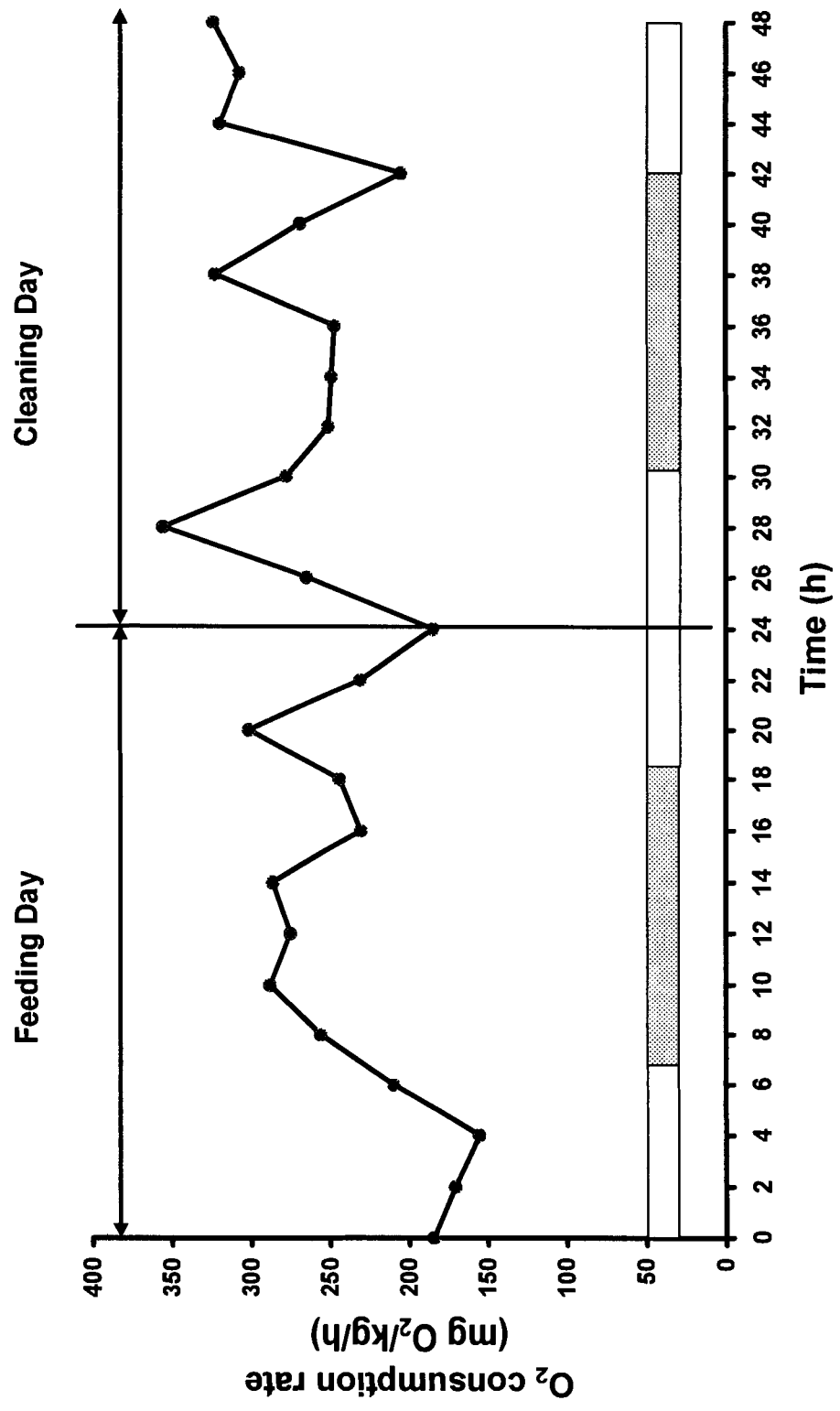

Figure 7. Daily mean oxygen consumption rates of juvenile rainbow trout during the 48-h pre-exposure and the 15-d pyrene exposure periods. Values are means \pm SE for 4 fish. The treatments were 0 mg/L (\circ) and 0.1 mg/L pyrene (\bullet). F indicates a feeding day and C indicates a cleaning day (n=12).

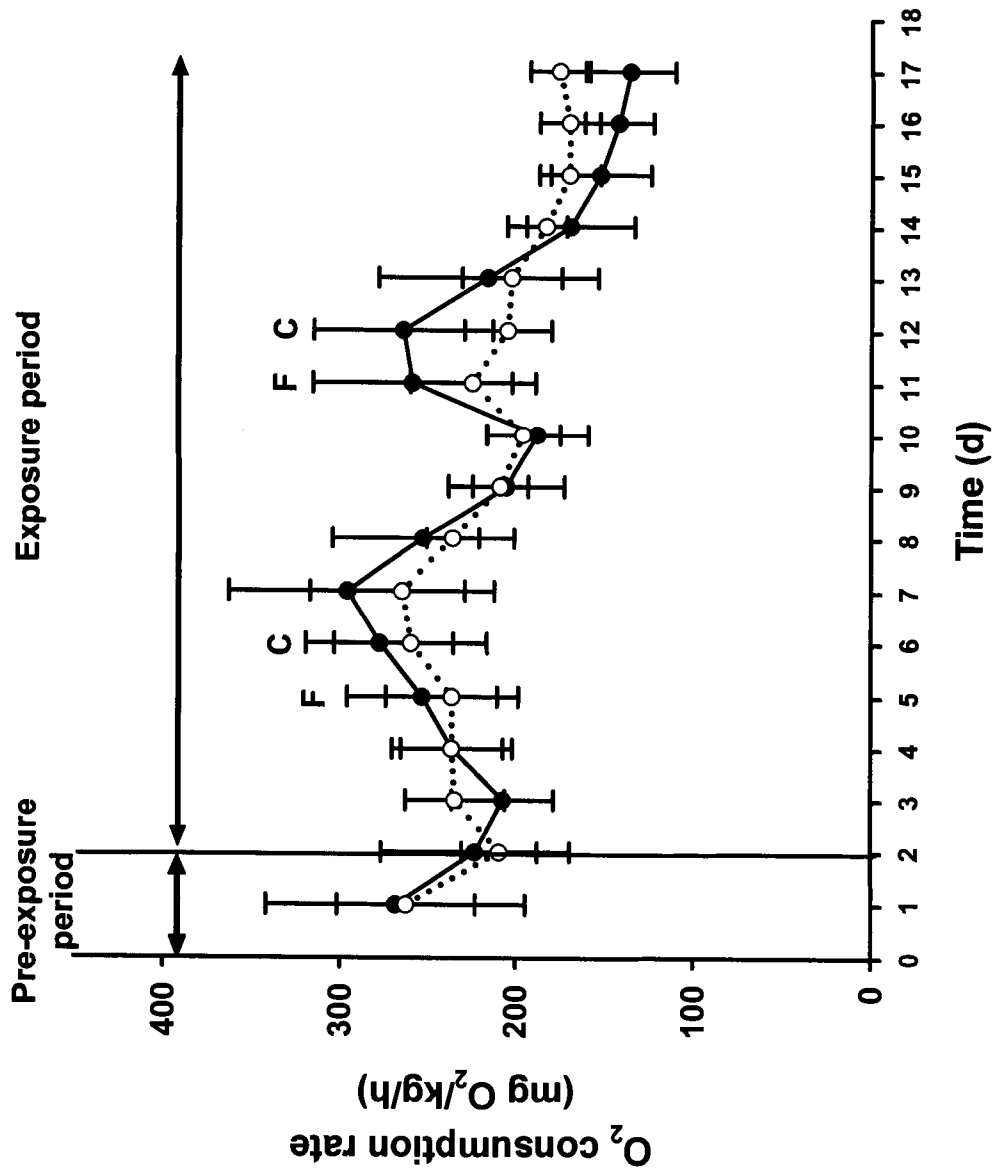
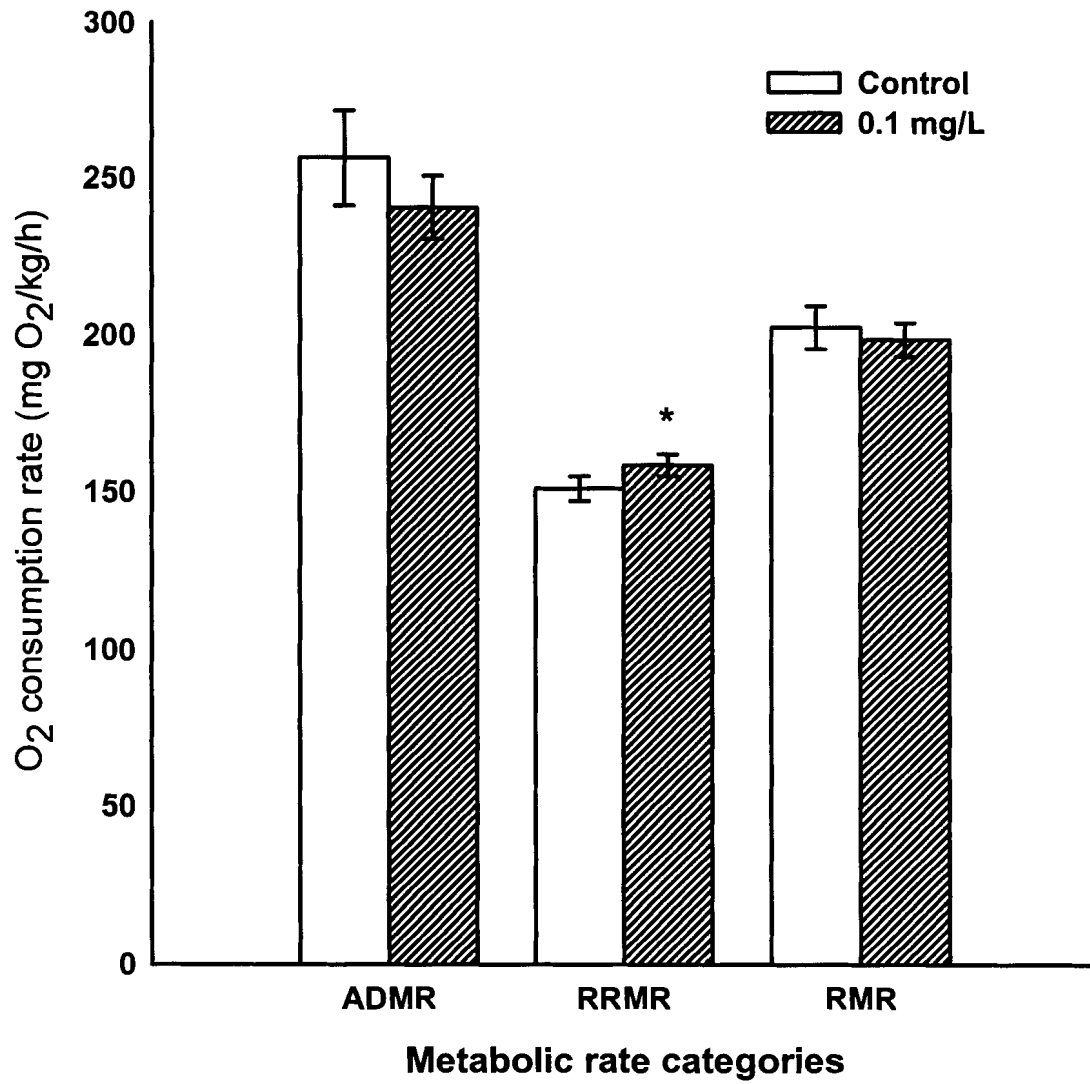

Figure 8. ADMR, RRMR and RMR of rainbow trout during a 15-d of control and 0.1 mg/L pyrene exposure. * indicates a significance difference from the 0 mg/L at $p \leq 0.05$ (n=38-42).



Metabolite analysis for the short-term experiment

In addition to examining metabolic rates, the metabolism of pyrene by rainbow trout was also examined in each treatment group in the short-term experiment. Bile in gall bladders was collected at the end of the experiment and then analyzed for 1-OH pyrene, the major metabolite of pyrene, using synchronous fluorometric spectroscopy (SFS). Figure 9 is an example of fluorescence intensity traces generated by SFS for several 1-OH pyrene concentrations. A major peak at approximately 345 nm and a small shoulder peak at approximately 360 nm occurred for all concentrations. Only the major peak was used to determine 1-OH pyrene concentration, although the small shoulder peak was also an emission peak attributed to 1-OH pyrene. This shoulder peak would be more pronounced if a conventional fluorescence emission spectrum was used instead of SFS; however, this would hamper an appropriate quantitative analysis of 1-OH pyrene concentration (Ariese *et al.*, 1993).

The standard curve generated for determining concentrations of 1-OH pyrene in bile using SFS is shown in Figure 10. The concentration of standards used ranged from 0.28 to 5.8 ng/ml 1-OH pyrene. The concentration of 1-OH pyrene and the generated baseline area exhibited a linear relationship. A mathematical equation that describes this linear relationship was used to determine biliary 1-OH pyrene concentration from baseline areas.

1-OH pyrene or its conjugate 1-OH pyrene glucuronide (1-OHPG) was found in all bile samples from fish exposed to pyrene. Control fish bile did not

contain any pyrene metabolites. Bile extracted from fish in the 0.05 and 0.10 mg/L treatment group contained significantly more pyrene metabolite when compared to bile of control fish and fish in 0.01 mg/L treatment ($p < 0.05$) (Figure 11), however, no statistical significant difference was found between the amount of 1-OH pyrene in the 0.05 and 0.10 mg/L treatment groups ($p > 0.05$).

Figure 9. Typical SFS spectra for several 1-OH pyrene concentrations. The net peak area between 335-356 emission wavelengths were used to determine the concentration of 1-OH pyrene present in the bile (from Bains, 2004).

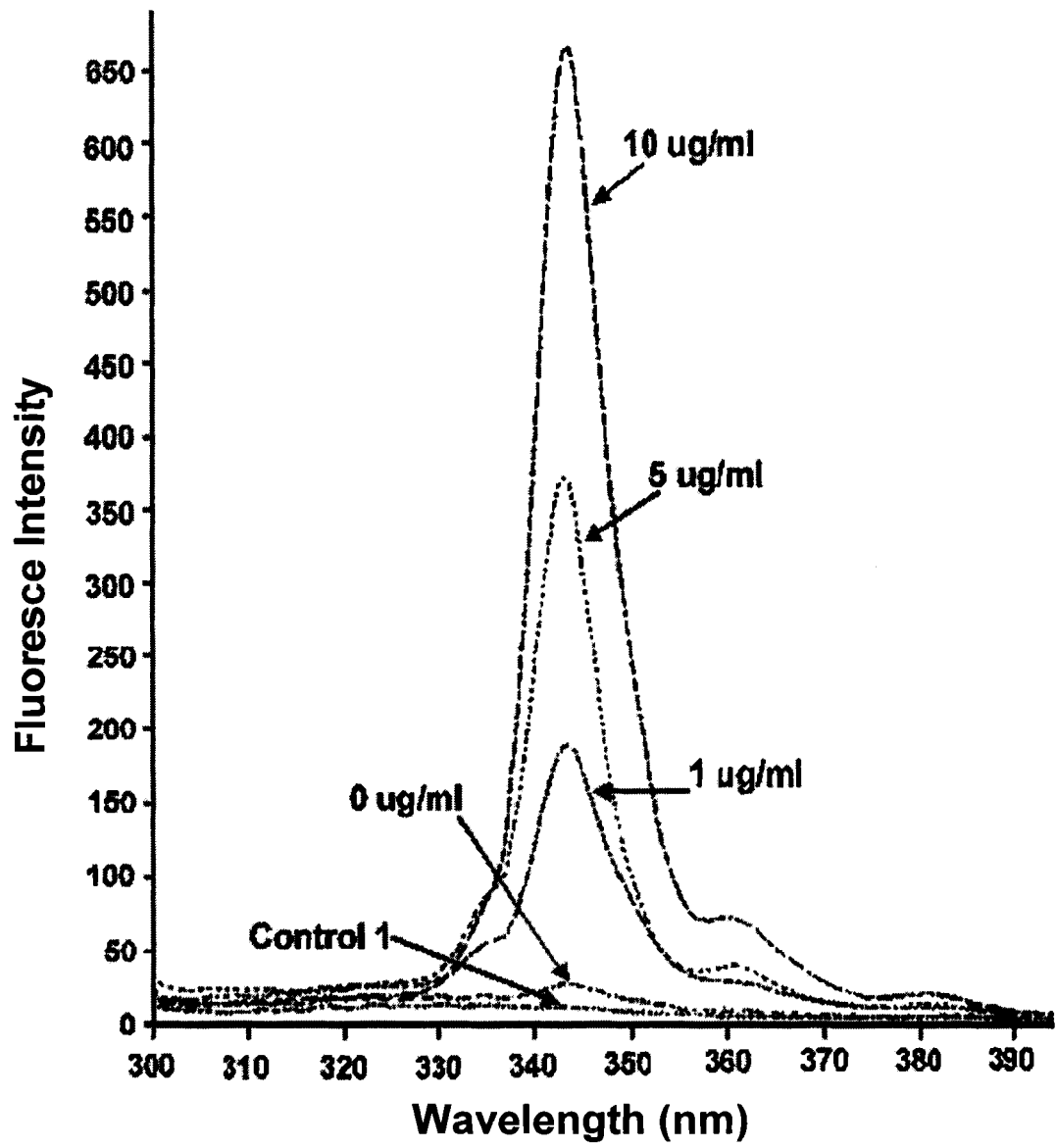

Figure 10. Standard curve constructed from net peak area (335-356 nm excitation wavelengths) of standard solutions of free 1-OH pyrene.

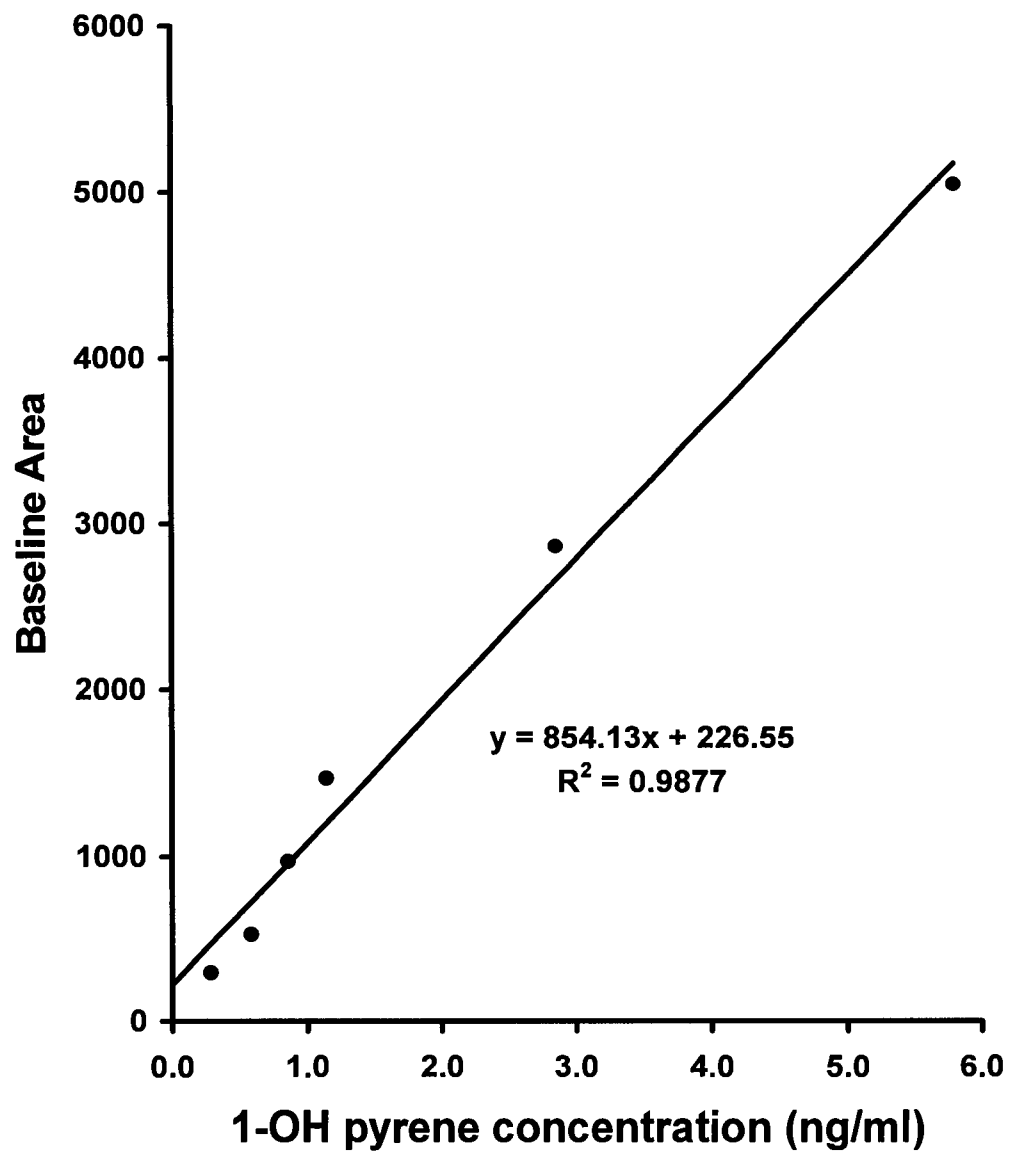
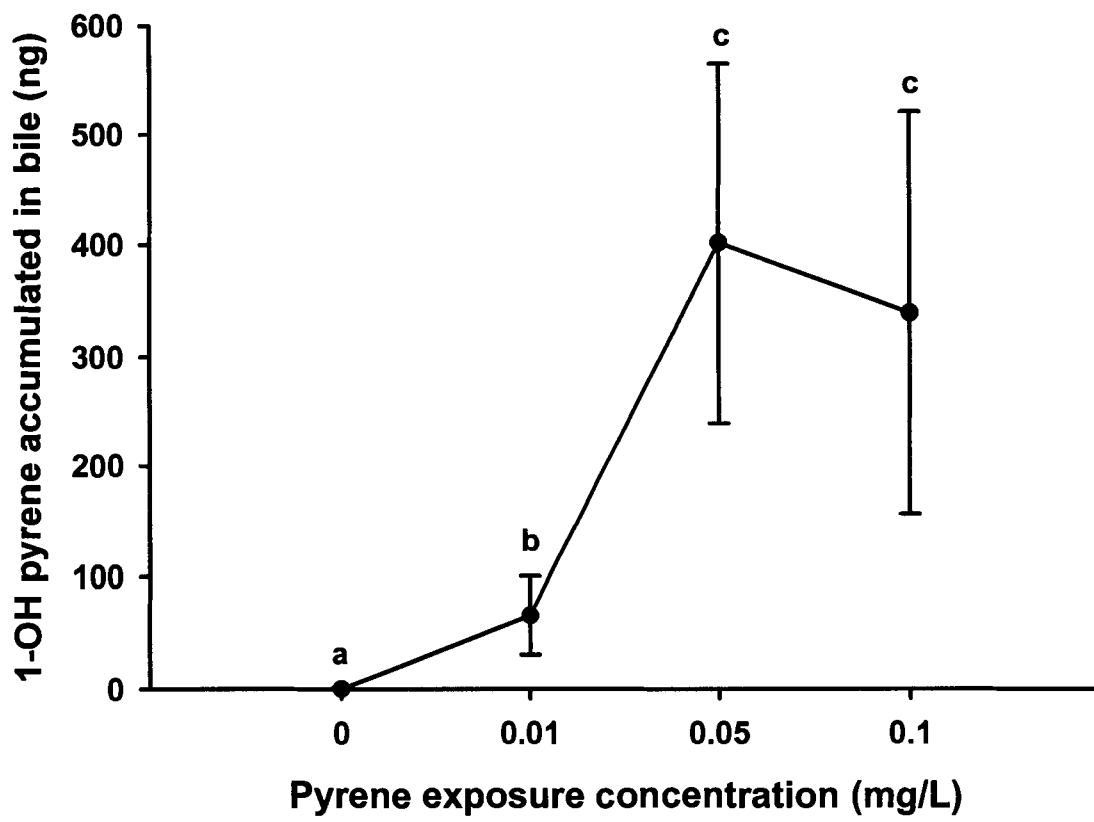

Figure 11. Biliary 1-OH pyrene extracted from the gall bladders of juvenile rainbow trout after exposure to 0, 0.01, 0.05, and 0.1 mg/L pyrene for 72 hours. Treatments with similar letters were not significantly different from each other at $p < 0.05$. Error bars represent means \pm SE (n=4-8).



DISCUSSION

Limited research on the costs of detoxification exists and has mainly been focused on plant specialization in insects and vertebrate foraging behaviour. Early studies attempted to estimate costs of detoxification by incorporating plant toxins into artificial diets and measuring the consequent changes in growth and food assimilation efficiency (Waldbauer, 1968; Schoonhoven and Meerman, 1978; Scriber, 1978, Scriber, 1981). In these studies, the results were confounded by toxicological impact, such as inhibited feeding. More recent studies began to examine the energetic costs by quantifying the resource allocation to a particular detoxification system such as the cytochrome P-450 system (Cresswell, 1992; Berenbaum and Zangerl, 1994; Cianfrogna *et al.* 2002). In these studies, the energetic costs were indirectly estimated as the energy allocated to detoxification from other components of energy budgets such as growth and reproduction. Potential toxicological effects on other components of energy budgets can confound with the measured energetic costs of detoxification.

It has been suggested that the biosynthetic energy costs of producing and maintaining detoxification enzymes might attribute to significant component of the energy budget of an organism smaller than a rodent (Brattsen, 1979). A study by Bains (2004) was the first to quantify the direct costs of xenobiotic metabolism and excretion at the cellular level using respirometry.

The objective of this study was to directly quantify the energetic costs of pyrene metabolism in juvenile rainbow trout by measuring oxygen consumption

rates in fish exposed to this chemical. Several studies have reported the effects of xenobiotic exposure on oxygen consumption in fish (Dalela, *et al.*, 1980; Prasad, *et al.*, 1991; De Boeck, *et al.*, 1995; Kim, *et al.*, 1996; Beyers, *et al.*, 1999). For example, Kim *et al.* reported that oxygen consumption rates were significantly increased by exposing fish to various concentrations of pentachlorophenol (PCP). However, it was likely that increases in oxygen consumption rates were caused by both the costs of detoxification and the toxic effects of the PCP. The test chemicals used in that and other studies of this nature have known toxicological effects in fish, therefore, separating out the energy allocated to detoxification from toxic effects is difficult.

The model chemical used in this study, pyrene, is relative non-toxic to fish at the concentrations used in this study (Kennedy and Law, 1990; Law *et al.*, 1991; Nisbet and Lagoy, 1992; Namdari and Law, 1996). No observable toxic effects in fish were detected in this study. Therefore, the confounding effects of toxic injury and its associated costs are likely negligible.

Energy used for metabolism is typically measured as oxygen consumption rates in fish biology (Adams and Breck, 1990). Oxygen uptake via respiration is important for the aerobic conversion of the energy assimilated from food to high energy chemical bonds. Hence, oxygen units can be converted to energy units with the oxycaloric average of 3.20 to 3.24 cal/mg O₂ depending on the species, size, and body fat/ protein composition (Brafield and Solomon, 1972).

In this study, oxygen consumption rate was measured using an automatic intermittent-flow through respirometer system. Metabolic rates were

differentiated into resting routine metabolic rate (RRMR), routine metabolic rate (RMR), and activity dependent metabolic rate (ADMR) according to a procedure modified from Cheng (2003). RRMR was assumed to be the rate generated when fish were relatively inactive while ADMR was generated when fish were active. RMR was the average of oxygen consumption rates that included RRMR and ADMR. This method permits a more detailed examination and comparison of metabolic rates in fish during active or resting states based on the relationship between oxygen consumption rate and activity.

Studies have shown that oxygen consumption rates increase with fish activity, and recording fish activity and oxygen consumption rate simultaneously can improve the accuracy of this differentiating metabolic rate method (Forstner and Wieser, 1990; Johansen and Geen, 1990). Forstner and Wieser (1990) studied the patterns of routine metabolic rate with a respirometer-activity-monitoring system, and found that activity was not always correlated with oxygen consumption rates at low temperature, however, the two variables were strongly correlated at higher temperature. They also distinguished between RRMR, RMR and "high cost" metabolic rates based on the level of activity at higher temperatures. The reported average standard metabolic rates, RMR and "high cost" metabolic rates for juvenile roach (*Rutilus rutilus* (L.)) in that study were 182, 230, 233 mg/kg/h at 15°C, respectively. In this study, the average RRMR, RMR and ADMR for the control juvenile rainbow trout in the short-term experiment were 148±42, 189±60, and 228±58 mg/kg/h at 13°C, respectively. The mean routine metabolic rate (RMR) values for the control juvenile rainbow trout were

217 ± 65 mg O₂/kg/h in the long-term experiments. These values are in accordance with studies conducted using similar sized salmonoids at similar water temperatures (Table 3).

In this study, temperature was controlled using air conditioning system in the experimental room. Respirometer vessels were housed in water bath to decrease temperature variation during the test. Therefore, the range of temperature differences over the whole study was less than 1.0°C in order to eliminate temperature effect on oxygen consumption rate. Several studies found that oxygen consumption rate was affected by temperature (Beamish, 1964; Beamish and Mookherjee, 1964; Caulton, 1978; Forstner and Wieser, 1990). Oxygen consumption rates can increase almost by two-fold over a 5°C of temperature difference in some species. The relationship between temperature and oxygen consumption rate may be due to more gill ventilation and higher activity levels at high temperatures.

A number of investigations relating oxygen consumption to fish weight had found oxygen consumption rates increased with fish weight (Beamish, 1964; Beamish and Mookherjee, 1964; Caulton, 1978, Saint Paul, 1988; Mitz and Newman; 1989; Cech, 1990; Forstner and Wieser, 1990; Grottum and Sigholt, 1998). The log-log plot of oxygen consumption rate (per fish) and body mass shows a linear relationship with a slope less than 1.0. Oxygen consumption rate per unit weight is greater for smaller fish than for larger fish (Beamish, 1964; Mitz and Newman, 1989, Cech, 1990). Thus, it is not advisable to divide oxygen consumption rate data by unit mass to compare rates of different size fish. In this

study, similar sizes of fish were used and distributed into each vessel in random order to avoid this potential confounding factor.

A characteristic circadian rhythm in fish oxygen consumption rates was detected in all fish. Circadian rhythms in fish oxygen consumption rates are common features in respirometry studies conducted in fixed dark and light photoperiods (Duval *et al.*, 1981; Forstner and Wieser, 1990; Johansen and Geen, 1990; Chakraborty, 1992; Yang and Randall, 1997; Biswas, 2002). This rhythm reflects the normal daily activity pattern of fish, where fish are more active and oxygen consumption rates are higher during light photoperiods than during dark periods (Brett and Zala, 1975). The length of photoperiod also affects the pattern, range and mean oxygen consumption rates (Chakraborty *et al.*, 1992; Biswas *et al.*, 2002). If the alternation of dark and light photoperiods becomes more frequent within a single day, the mean oxygen consumption rates also increase (Chakraborty *et al.*, 1992; Biswas *et al.*, 2002). Circadian rhythm is most pronounced for 12L:12D and become less visible when either period increases or decreases. Chakraborty *et al.* (1992) proposed that the effect of photoperiod on oxygen consumption rates is related to the endocrine system which controls various physiological activities. For example, manipulation of the dark and light photoperiods has a stimulating effect on production of growth hormone, thyroid activity, plasma cortisol patterns (Bjornsson, 1997; Reddy and Leatherland, 2003), and gill Na^+ , K^+ -ATPase (McCormick *et al.*, 1995).

This study was done under a 12 h light: 12 h dark photoperiod, and the oxygen consumption rates varied significantly between light and dark periods.

The magnitude of variation within a day was approximately 100 mg O₂/kg/h for rainbow trout in this study compared to 400 mg O₂/kg/h for tilapia (*Oreochromis niloticus*) in the study conducted by Biswas *et al.* (2002) and 35 mg O₂/kg/h for carp (*Cyprinus carpio*) (Chakraborty *et al.*, 1992). Chakraborty *et al.* (1992) found that the range of mean difference in oxygen consumption rate over 24 hour period was approximately 10 mg O₂/kg/h in a 24 h dark photoperiod compared to 35 mg O₂/kg/h in a 12 h light :12 h dark photoperiod. The daily magnitude of variation can potentially mask the effects of study interest, therefore, a complete dark photoperiod should be considered for the future studies of this nature.

In the short-term experiment, pre-exposure and exposure metabolic rates were significant different from each other for all treatment groups. However, no concentration-response relationship between pyrene and RRMR, ADMR, or RMR was detected during the exposure period (Table 3). Therefore, the energetic costs of pyrene detoxification could not be quantified using oxygen consumption rates in the short-term experiment.

Data recorded in the first 6 hours of the experiment were excluded from calculations due to a substantial stress effect on oxygen consumption rates which persisted throughout the entire pre-exposure period. As a result, the daily mean oxygen consumption rates showed declines and leveling off (Figure 5). Control fish had the highest percentage metabolic rate reduction between pre-exposure and exposure periods while the 0.1 mg/L pyrene-exposed fish had the lowest (Table 2). One explanation for this observation is that the control fish

recovered from the initial stress while the pyrene exposed fish could only recover partially but remained stressed because of pyrene exposure.

Stress can contribute to considerable increases in oxygen consumption rates. In this study, oxygen consumption rates were high at the beginning of all experiments likely due to the initial acute handling stress. Acute handling stress resulted in high oxygen consumption rates in similar respirometry studies (Saint-Paul *et al.*, 1988; Johansen and Geen, 1990; Yang and Randall, 1997; Jayaweera, 2002; Cheng, 2003). The time required for oxygen consumption rates to stabilize ranged between 2 and 12 hours in these studies. When fish experience stress, catecholamine and cortisol are released into the circulation and initiate a series of physiological responses, including changes in plasma glucose and lactate concentrations to help fish cope with stress by providing energy (Vijayan and Moon, 1992, 1994; Krumschnabel and Lackner, 1993). These hormonal responses lead to the alteration of glycogen and glucose metabolism as secondary stress responses (Vijayan *et al.*, 1991). Catecholamines play an important role in elevating oxygen consumption rates in stressed fish. These compounds bind to β -adrenoreceptors and amplify oxygen uptake and its rate of delivery (Randal and Perry, 1992). Catecholamines also increase the surface area available for gas exchange in the gill vasculature through the vasodilation of gill lamellae and the permeability of the gill epithelium to oxygen. Moreover, catecholamines can mediate increases in heart rate and blood pressure and result in increased oxygen delivery to tissues (Mazeaud and Mazeaud, 1981). In order to exclude the effect of the stress response on oxygen

consumption rates, the data recorded during the first 6 hours of the present experiments were excluded from data analysis.

Fish bile was collected from gall bladders for metabolite analysis at the end of the short-term experiment. Namdari (1998) showed that pyrene was extensively metabolized by starry flounder (*Platichthys stellatus*), and that approximately 40% of administered pyrene was excreted as metabolites in bile 120 h following intra-arterial dose of 10 mg/kg. Kennedy (1990) reported that 53% of intra-arterially administered pyrene was excreted as metabolites in the bile of rainbow trout. The major pyrene metabolites were 1-OH pyrene and its glucuronide conjugates (Krhan *et al.*, 1987; Kennedy and Law, 1990; Law *et al.*, 1991; Law *et al.*, 1994; Namdari, 1998). Many aquatic organisms metabolize organic xenobiotics, such as pyrene, by the mixed-function oxidase (MFO) system via phase I biotransformation reactions. MFO, a multi-enzyme complex, metabolizes pyrene through oxidation reactions into metabolites such as 1-OH pyrene. Subsequently, 1-OH pyrene is metabolized by conjugation reactions to form highly water soluble metabolites through phase II biotransformation reactions. The majority of biliary 1-OH pyrene existed as glucuronide conjugates and was seldom detected in the non-conjugated form (Law *et al.*, 1994; Namdari, 1998). Therefore, biliary 1-OH pyrene glucuronide (1-OHPG) and 1-OH pyrene concentrations were deemed to be good estimators of pyrene metabolism.

In this project, the amount of biliary 1-OH pyrene was analyzed using synchronous fluorescence spectrometry (SFS) because SFS provides rapid and

reliable quantitative results using small sample sizes. When analyzing bile, the SFS peaks for 1-OH pyrene and 1-OHPG overlap. However, no commercial 1-OHPG is available to prepare solutions for standard curves. Instead, a series of 1-OH pyrene solutions were used for a standard curve. A concentration correction factor of 2.2 suggested by Ariese *et al.* (1993) was applied to calculate the concentration of 1-OH pyrene from the areas underneath the fluorescence intensity traces generated by 1-OHPG. The control, 0.01 mg/L and 0.05 mg/L pyrene groups of fish had significantly different amounts of biliary 1-OHPG after 72 hours of pyrene exposure. A concentration-response relationship existed between the amount of biliary 1-OH pyrene and the exposed pyrene concentration below 0.05 mg/L. Biliary 1-OH pyrene in the 0.05 and 0.1 mg/L treatment groups were not significantly different. Moreover, the magnitude of variation in biliary 1-OH pyrene excretion was greater in the 0.05 mg/L and 0.10 mg/L treatment groups compared to the 0.01 mg/L treatment group and the control. Both Namdari (1998) and Giessing *et al.* (2003) also found the magnitude of biliary 1-OH pyrene variation increased with exposure length and exposed pyrene concentration.

In the long-term experiment, fish were exposed to 0 and 0.1 mg/L pyrene for 15 days with feeding on days 5 and 11. Although fish were starved 24-hr before test initiation to ensure a post-prandial state, fish were fed twice during long term experiment. During preliminary experiments, fish became unhealthy after being starved for one week. The mortality of control fish ranged from 10% to 20% in a 17-day trial experiment without feeding which is an unacceptable

mortality rate for toxicological testing. Moreover, energy metabolism enzymes are sensitive to nutritional stress and can decrease during starvation (Heath, 1995), and can result in decreased oxygen consumption rates (Biswas and Takeuchi, 2002). Therefore, feeding was performed twice during the long-term experiments. Oxygen consumption rates increased significantly on both the feeding and cleaning days. The elevated oxygen consumption rates during feeding and cleaning periods were associated with the extra energy used for digestion (Biswas and Takeuchi, 2002) and the stress associated with cleaning. The post-prandial increase in metabolic rate results from the energy requirements for the digestion, absorption and storage of nutrients, for the deamination of amino acids and for the synthesis of excretory products (Jobling, 1993). Therefore, these elevated oxygen consumption rates were excluded from calculation.

A paired comparison of ADMR and RMR between the two pyrene treatment groups did not show any significant difference, however, a significant difference was found in RRMR between the control and the pyrene exposed groups ($p < 0.05$). This marginal increase in RRMR of the pyrene exposed group implied that the energetic costs of detoxification were evident, however small. The energetic costs were not likely to be detected in ADMR and RMR measures, because ADMR and RMR were metabolic rates determined when fish were active, whereas RRMR was the metabolic rate calculated with little or no activity. Both ADMR and RMR values had greater variation associated with them compared to RRMR (Figure 8). Therefore, fish activity may have masked the

energetic costs of detoxification in ADMR and RMR values because the energy used in detoxification was not a large component of the bioenergetic budget compared to other more variable activities.

Conclusion

From the results of this study, it appears that there may be a minimal cost associated with the detoxification of pyrene as shown by the small, but significant, increase in RRMR in the 15-d exposed fish. While oxygen consumption rate can be accurate measures of metabolism for the purpose of bioenergetic studies, its sensitivity in detecting small energetic costs may be marginal. Various factors discussed previously (e.g. stress, feeding, circadian rhythms, and activity) likely contributed to the wide range of oxygen consumption rates seen in this study and can potentially mask smaller effects of interest. Energy allocation from other components of the energy budget may also potentially minimize the ability in detection by respirometry methods. Future studies should consider using relatively inactive species that can survive long-term without feeding in order to minimize the confounding effects contributed by activity, feeding and associated stress. Future studies may also consider using species that live in dark natural habitats so experiments can be conducted in complete darkness to minimize the effects of circadian rhythms. The weight of test animals should be examined at both test initiation and termination to determine if energy was allocated from growth to detoxification or other processes during exposure. The main goal of these considerations is to

measure the standard metabolic rate, the rate of energy use by a fasting fish at rest, so that the small energetic costs associated with detoxification will be more evident and more easily quantified.

Table 3. Literature values of routine metabolic rates of salmonoids at temperature range of 7-15°C

Species	Weight (g)	Temperature (°C)	Routine metabolic rate (mg O ₂ /kg/hr)	Reference
Sockeye	3.4	15	230	Brett (1965)
Rainbow trout	3.0	6	111	Cheng (2003)
Rainbow trout	4.5	12	200	Jayaweera (002)
Rainbow trout	7.3	12	189-217	Present study
Coho	11	7	120	Janz <i>et al.</i> (1991)
Coho	25	12	97	MacKinnon and Farrell (1993)
Rainbow trout	45	7	75	Yang and Randall (1997)
Rainbow trout	210	13.5	95	Skidmore (1970)

REFERENCES

- Adams, S.M. and Breck, J.E., 1990. Bioenergetics. In Schreck, C.B. and Moyle, P.B. (Eds.), *Methods for Fish Biology*. American Fisheries Society, Bethesda, Maryland, pp. 389-415.
- Appel, H.M. and Martin, M.M., 1992. Significance of metabolic load in the evolution of host specificity of *Manduca sexta*. *Ecology*, 73(1), 216-228.
- Arfsten, D.P., Schaeffer, D.J., and Mulveny, D.C., 1996. The effects of near ultraviolet radiation on the toxic effects of polycyclic aromatic hydrocarbons in animals and plants: a review. *Ecotoxicology and Environmental Safety*, 33, 1-24.
- Ariese, F., Kok, S.j., Verkaik, m., Gooijer, C., Velthorst, N.H., and Hofstraat, J.W., 1993. Synchronous fluorescence spectrometry of fish bile: a rapid screening method for the biomonitoring of PAH exposure. *Aquatic Toxicology*, 26, 273-286.
- Bains, O., 2004. Energetic costs of pyrene metabolism in isolated hepatocytes of rainbow trout (*Oncorhynchus mykiss*). M.E.T. Project, Simon Fraser University, B.C., Canada.
- Beamish F.W.H., 1964. Seasonal changes in the standard rate of oxygen consumption of fishes. *Canadian Journal of Zoology*, 42, 189-194.
- Beamish, F.W.H. and Mookherjee, P.S., 1964a. Respiration of fishes with special emphasis on standard oxygen consumption I: influence of weight and temperature on respiration of goldfish, *Carassius auratus* L. *Canadian Journal of Zoology*, 42, 161-175.
- Beamish, F.W.H. and Mookherjee, P.S., 1964b. Respiration of fishes with special emphasis on standard oxygen consumption II: influence of weight and temperature on respiration of several species. *Canadian Journal of Zoology*, 42, 177-188.
- Berenbaum, M.R. and Zangerl, A.R., 1994. Costs of inducible defence: protein limitation growth, and detoxification in parsnip webworms. *Ecology*, 75(8), 2311-2317.
- Berg, K., Lumbye, J., and Ockelmann, K.W., 1958. Seasonal and experimental variation the oxygen consumption of the limpet, *Anaclytus fluviatilis*. *Journal of Experimental Biology*, 35, 43-73.
- Beyers, D. W., Rice, J.A., and Clements, W.H., 1999a. Evaluating biological significance of chemical exposure to fish using a bioenergetics-based stressor response model. *Canadian Journal of Fisheries and Aquatic Sciences*, 56(5), 823-822.

- Beyers, D.W., Rice, J.A., Clements, W.H., and Henry, C.J., 1999b. Estimating physiological cost of chemical exposure: integrating energetics and stress to quantify toxic effects in fish. *Canadian Journal of Fisheries and Aquatic Sciences*, 56(5), 814-822.
- Biswas, A.K. and Takeuchi, T., 2002. Effect of different photoperiod cycles on metabolic rate and energy loss of fed and unfed adult tilapia *Oreochromis niloticus*: Part II. *Fisheries Science*, 68, 573-553.
- Biswas, A.K., Endo, M., and Takeuchi, T., 2002. Effect of different photoperiod cycles on metabolic rate and energy loss of fed and unfed adult tilapia *Oreochromis niloticus*: Part I. *Fisheries Science*, 68, 465-477.
- Bjornsson, B.T., 1997. The biology of salmon growth hormone: from daylight to dominance. *Fish Physiology and Biochemistry*, 17, 9-24.
- Brafield, A.E. and Solomon, D.J., 1972. Oxy-calorific coefficients for animals respiring nitrogenous substrates. *Comparative Biochemistry and Physiology A, Comparative Physiology*, 43, 837-841.
- Brattsen, L.B., 1979. Biochemical defense mechanisms in herbivores against plant allelochemicals. In: Rosental, G.A. and Janzen, D.H. (Eds.), *Herbivores, their interaction with secondary plant metabolites*. Academic Press, New York, pp200-269.
- Brattsten, L.B., 1988. Enzymic adaptations in leaf-feeding insects to host-plant allelochemicals. *Journal of Chemical Ecology*, 14(10), 1919-1935.
- Brett, J.R. and Zala, C.V., 1975. Daily pattern of nitrogen excretion and oxygen consumption of sockeye salmon (*Oncorhynchus nerka*) under controlled conditions. *Journal of Fisheries and Research Board of Canada*, 32(12), 2479-2486.
- Burggren, W.W. 1979. Bimodal gas exchange variation in environmental oxygen and carbon dioxide in air-breathing fish, *Trichogaster trichopterus*. *Journal of Experimental Biology*, 82, 197-213.
- Caulton, M.S., 1978. The effect of temperature and mass on routine metabolism in *Sarotherodon (Tilapia) mossambicus* (Peters). *Journal of Fish Biology*, 13, 195-201.
- Cech, J.J., 1990. Respirometry. In Schreck, C.B. and Moyle, P.B. (Eds.), *Methods for Fish Biology*. American Fisheries Society, Bethesda, Maryland, pp. 350-362.
- Chakraborty, S.C., Ross, L.G., and Ross, B., 1992. The effect of photoperiod on the resting metabolism of carp (*Cyprinus carpio*). *Comparative Biochemistry and Physiology*, 101A(1), 77-82.
- Cheng, W. W-L., 2003. Acute and Sublethal Toxicities of Rotenone in Juvenile Rainbow Trout (*Oncorhynchus mykiss*). M.E.T. Project, Simon Fraser University, B.C., Canada.

- Cianfrogna, J.A., Zangerl, A.R., and Berenbaum, M.R., 2002. Dietary and developmental influences on induced detoxification in an oligophage. *Journal of Chemical Ecology*, 28(7), 1349-1363.
- Cresswel, J.E., Merritt, S.Z., and martin, M.M., 1992. The effect of dietary nicotine on the allocation of assimilated food to energy metabolism and growth in fourth-instar larvae of the southern armyworm, *Spodoptera eridania* (Lepidoptera: Noctuidae). *Oecologia*, 89 (3), 449-453.
- Dalela, R.C., Bansal, S.K., Gupta, A.K., Verma, S.R., 1980. Short-term stress on the oxygen consumption of a fresh water teleost *Saccobranchnus fossilis* following lethal and sublethal levels of chlordance, Metasystox, and Sevin. *International Journal of Environmental Studies*, 15(3), 229-235.
- Dash, J.A., 1988. Effects of dietary terpenes on glucuronic acid excretion and ascorbic acid turnover in the brushtail possum, *Trichosurus vulpecula*, *Comparative Biochemistry and Physiology*, 89B(2), 221-226.
- De Boeck, G., De Smet, H., and Blust, R., 1995. The effect of sublethal levels of copper on oxygen consumption and ammonia excretion in the common carp, *Cyprinus carpio*. *Aquatic Toxicology*, 32(2-3), 127-141.
- Demas, G., Chefer, V., Talan, M.I., and Nelson, R.J., 1997. Metabolic costs of mounting an antigen-stimulated immune response in adult and aged C57bl/6J mice. *American Journal of Physiology*, 273(5), R1631-R1637.
- Derting, T.L. and Compton, S., 2003. Immune response, not immune maintenance, is energetically costly in wild white-footed mice (*Peromyscus leucopus*). *Physiological and Biochemical Zoology*, 76(5), 744-752.
- Duval, W.S., Fink, R.P., and Geen, G.H., 1981. An aquatic respirometer for use in sublethal studies. *Water Research*, 15, 817-822.
- Foly, W.J., 1992. Nitrogen and energy retention and acid-base status in the common ringtail possum, *Pseudocheirus peregrinus*, evidence of the effects of absorbed allelochemicals. *Physiological Zoology*, 65(2), 403-421.
- Forstner, H. and Wieser, W., 1990. Patterns of routine swimming and metabolic rate in juvenile cyprinids at three temperatures: analysis with a respirometer-activity-monitoring system. *Journal of Comparative Physiology B*, 160, 71-76.
- Fry, F.F.J., 1957. The aquatic respiration of fish. In: the Brown, M.E. (Ed.), *the Physiology of Fishes: volume 1*, Academic Press, New York, pp. 1-63.
- Giessing, A.M.B., Mayer, L.M., and Forbes, T.L., 2003. Synchronous fluorescence spectrometry of 1-hydroxypyrene: a rapid screening method for identification of PAH exposure in tissue from marine polychaetes. *Marine Environmental Research*, 56, 599-615.

- Guglielmo, C.G., and Karasov, W.H., 1996. Nutritional costs of a plant secondary metabolite explain selective foraging by refted grouse. *Ecology*, 77(4), 1103-1115.
- Hase, A. and Hites, R.A., 1978. On the origin of polycyclic aromatic hydrocarbons in the aqueous environment. In Keith, L.H. (Ed), *Identification and Analysis of Organic Pollutants in Water*, Ann arbour Science, Ann Arbor, MI.
- Heath, A.G., 1995. *Water pollution and fish physiology*, 2nd ed., CRC Press, Boca Raton, Fl, pp. 359.
- Helder, T., 1981. Effects of 2,3,7,8-tetrachlorodibenzo-dioxin (TCDD) on early life stages of rainbow trout (*Salmo gairdneri*, Richardson). *Toxicology*, 19(2), 101-112.
- Henken, A.M. and Bradsma, H.A., 1982. The effect of environmental temperature on immune response and metabolism of the young chicken. II. Effect of the immune response to sheep red blood cells on energy metabolism. *Poultry Science*, 61(8), 1667-1673.
- Janz, D.M., Farrel, A.P., Morgan, J.D., and Vigers, G.A., 1991. Acute physiological stress responses of juvenile coho salmon (*Oncorhynchus kisutch*) to sublethal concentrations of Garlon 4[®], Garlon 3A[®], and Vision[®] herbicides. *Environmental Toxicology and Chemistry*, 10, 81-90.
- Jayaweera, D., 2002. Investigation of Acute Sublethal Effects of Rotenone on the Routine Oxygen Uptake of Juvenile Rainbow Trout (*Oncorhynchus mykiss*). M.E.T. Project, Simon Fraser University, B.C., Canada.
- Jobling M., 1993. Bioenergetics: feed intake and energy partitioning. In Rankin, J.C. and Jensen, F.B. (Eds.), *Fish Ecophysiology*, Chapman & Hall, New York, pp. 1-44.
- Johansen, J.A. and Geen, G.H., 1990. Sublethal and acute toxicity of the ethylene glycol butyl ether ester formulation of triclopyr to juvenile coho salmon (*Oncorhynchus kisutch*). *Archives of Environmental Contamination and Toxicology*, 19, 610-616.
- Kennedy, C.J. and Law, F.C.P., 1990. Toxicokinetics of selected polycyclic aromatic hydrocarbons in rainbow trout following different routes of exposure. *Environmental Toxicology and Chemistry*, 8, 863-869.
- Kennedy, C.J., 1990. Toxicokinetic studies of chlorinated phenols and polycyclic aromatic hydrocarbons in rainbow trout (*Oncorhynchus mykiss*). Ph.D. Thesis., Simon Fraser University, Burnaby, B.C., Canada.
- Kennedy, C.J., Gill, K.A., and Waish, P.J., 1991. Temperature acclimation of xenobiotic metabolizing enzymes in cultured hepatocytes and whole liver of the gulf toadfish, *Opsanus beta*. *Canadian Journal of Fisheries and Aquatic Science*, 48, 1212-1219.

- Kim, S.D., Jeon, J.K., Lee, S.H., and Huh, H.T., 1996. Effects of pentachlorophenol (PCP) on the oxygen consumption rate of the river puffer fish, *Takifugu obscurus*. *Marine Ecology Progress Series*, 143, 9-14.
- Kitchell, J.F., 1983. Energetics. In Webb, P.W. and Weihs, D. (Eds.), *Fish Biomechanics*, Praeger Publishers, New York, pp. 312-338.
- Krahn, M.M., Burrows, D.G., Macleod, J.W.D., Malins, D.C., 1987. Determination of individual metabolites of aromatic compounds in hydrolyzed bile of English sole (*Parophrys vetulus*) from polluted sites in Puget Sound, Washington. *Archives of Environmental Contamination and Toxicology*, 16(5), 511-522.
- Krisfalusi, M., Eroschenkno, V.P., Cloud, J.G., 1998. Exposure of juvenile rainbow trout (*Oncorhynchus mykiss*) to methoxychlor results in a dose-dependent decrease in growth and survival but does not alter male sexual differentiation. *Bulletin of Environmental Contamination and Toxicology*, 60(4), 659-666.
- Krumschnabel, G. and Lackner, R., 1993. Stress responses in rainbow trout *Oncorhynchus mykiss* Alevins. *Comparative Biochemistry and Physiology*, 104A(4), 777-783.
- Landrum, P.F., 1998. Bioavailability and toxicokinetics of polycyclic aromatic hydrocarbons sorbed to sediments for the amphipod *Pontoporeia hoyi*. *Environmental Science and Technology*, 23, 588-595.
- Lardner, B. and Loman, J., 2003. Growth or reproduction? Resource allocation by female frogs *Rana temporaria*. *Oecologia*, 137, 541-546.
- Lardner, B. and Loman, J., 2003. Growth or reproduction? Resource allocation by female frogs *Rana temporaria*. *Oecologia*, 137, 541-546.
- Law, F.C.P., Abedini, S., and Kennedy, C.J., 1991. A biologically based toxicokinetic model for Pyrene in rainbow trout. *Toxicology and Applied Pharmacology*, 110, 390-402.
- Law, F.C.P., Meng, J.X., and He, Y.T., 1994. Urinary and biliary metabolites of Pyrene in rainbow trout (*Oncorhynchus mykiss*). *Xenobiotica*, 24(3), 221-229.
- Lee, R.F., Sauerheber, R., Dobbs, G.H., 1972. Uptake, metabolism and discharge of polycyclic aromatic hydrocarbons by marine fish. *Marine Biology*, 17, 201-208.
- Levin, J.O., 1995. First international workshop on hydroxyrene as a biomarker for PAH exposure in man – summary and conclusions. *Science of the Total Environment*, 163 (1-3), 164-168.

- Lin, E.L.C., Cormier, S., Racine, R.N., 1994. Synchronous fluorometric measurement of metabolites of polycyclic aromatic hydrocarbons in the bile of brown bullhead. *Environmental Toxicology and Chemistry*, 13, 707-715.
- Lindroth, R.L. and Batzli, G.O., 1984. Plant phenolics as chemical defenses effects of natural phenolics on survival and growth of prairie voles. *Journal of Environmental Ecology*, 10(2), 229-244.
- Mackinnon, D.L. and Farrell, A.P., 1992. The effect of 2-(thiocyanomethylthio)benzothiazole on juvenile coho salmon (*Oncorhynchus kisutch*) sublethal toxicity testing. *Environmental Toxicology and Chemistry*, 11, 1541-1548.
- Maryanski, M., Kramarz, P., Iaskowski, R., Niklinska, M., 2002 Decreased energetic reserves, morphological changes and accumulation of metals in carabid beetles (*Poecillus cupreus* L.) exposed to zinc- or cadmium-contaminated food. *Excotoxicology*, 11, 127-139.
- Mazeaud, M.M. and Mazeaud, F., 1981. Adrenergic response to stress in fish. In: Pickering, A.D. (Ed.), *Stress and Fish*, Academic Press, New York, pp. 49-75.
- McCormick, S.D., Bjornsson, B.T., Sheridan, M., Eilertson, C., Carey, J.B., and O'Dea, M., 1995. Increased daylength stimulates plasma growth hormone and gill Na⁺, K⁺-ATPase in Atlantic salmon (*Salmo salar*). *Journal of Comparative Physiology B Biochemical Systemic and Environmental Physiology*, 165(4), 245-254.
- Mitz, S.V. and Newman, M.C., 1989. Allometric relationship between oxygen consumption and body weight of mosquitofish, *Gambusia affinis*. *Environmental Biology of Fishes*, 24(4), 267-273.
- Mondon J.A., Duda, S., and Nowak, B.F., 2001. Histological, growth, and 7-ethoxyresorufin O-deethylase (EROD) activity responses of greenback flounder *Rhombosolea tapirina* to contaminated marine sediment and diet. *Aquatic Toxicology*, 54, 231-247.
- Namdari, R. and Law, F.C.P., 1996. Toxicokinetics of water borne pyrene in rainbow trout (*Oncorhynchus mykiss*) following branchial or dermal exposure. *Aquatic Toxicology*, 35 (3-4), 221-235.
- Namdari, R., 1998. A physiologically based toxicokinetic model of pyrene and its major metabolites in sally flounder (*Platichthys stellatus*). Ph.D. Thesis, Simon Fraser University, Burnaby, B.C., Canada.
- Nisbet, I.C.T., and Lagoy, P.K., 1992. Toxic equivalency factors (TEFs) for polycyclic aromatic hydrocarbons (PAHs). *Regulatory Toxicology and Pharmacology*, 16, 290-300.

- NRCC., 1983. Polycyclic aromatic hydrocarbons in the aquatic environment: formation, sources, fate and effects on aquatic biota. NRCC associate committee on scientific criteria for environmental quality. National Research Council of Canada, NRCC, No. 18981.
- Ogle, R.S. and Knight, A.W., 1989. Effects of elevated foodborne selenium on growth and reproduction of the fathead minnow (*Pimephales promelas*). *Archives of Environmental Contamination and Toxicology*, 18, 795-803.
- Post, J.R. and Parkinson, E.A., 2004. Energy allocation strategy in young fish: allometry and survival. *Ecology*, 82(4), 1040-1051.
- Prasad, T.A.V., Srinivas, T., Rafi, G.M., and Reddy, D.C., 1991. Effect *in vivo* of atrazine on haematology and oxygen consumption in fish, *Tilapia mossambica*. *Biochemistry International*, 23(1), 157-162.
- Randall, D.J. and Perry, S.F., 1992. Catecholamines. In: Hoar, W.S., Randall, D.J., and Farrell, A.P. (Eds.), *Fish Physiology, Vol XIIB*. Academic Press, New York, pp. 255-300.
- Reddy, P.K. and Leatherland, J.F., 2003. Influences of photoperiod and alternate days of feeding on plasma growth hormone and thyroid hormone levels in juvenile rainbow trout. *Journal of Fish Biology*, 63, 197-212.
- Rice, J.A., Breck, J.E., Bartell, S.M., and Kitchell, J.F., 1983. Evaluating the constraints of temperature, activity and consumption on growth of largemouth bass. *Environmental Biology of Fishes*, 9, 263-275.
- Robbins, C.T., Hagerman, A.E., Austin, P.J., MacArthur, C., and Hanley, T.A., 1991. Variation in mammalian physiological responses to a condensed tannin and its ecological implication. *Journal of Mammalogy*, 72, 460-486.
- Robbins, C.T., Hanley, T.A., Hagerman, A.E., Hjeljord, O., Baker, D.L., and Mautz, W.W., 1987. Role of tannins in defending plants against ruminants: reduction in protein availability. *Ecology*, 68(1), 98-107.
- Ruddock, P.J., Bird, D.J., and McCalley, D.V., 2002. Bile metabolites of polycyclic aromatic hydrocarbons in three species of fish from the Severn Estuary. *Ecotoxicology and Environmental Safety*, 51(2), 97-105.
- Saint-Paul, U., Hubold, G., and Ekau, W., 1988. Acclimation effects on routine oxygen consumption of the Antarctic fish *Pogonophryne scotti* (Arteidraconidae). *Polar Biology*, 9, 125-128.
- Samuels, M.L., 1989. *Statistics for the Life Sciences*. Dellen Publishing Co., San Francisco, California.
- Sandland, G.J. and Minchella, D.J., 2003. Effects of diet and *Echinostoma revolutum* infection on energy allocation patterns in juvenile *Lymnaea elodes* snails. *Oecologia*, 134, 479-486.
- Schoonhoven, L.M. and Meerman, J., 1978. Metabolic cost of changes in diet and neutralization of allelochemicals. *Entomologia Experimentalis et Applicata*, 24, 489-493.

- Scriber, J.M., 1978. Cyanogenic glycosiders in *Lotus corniculatus*: their effects upon growth, energy budget, and nitrogen utilization in the southern armyworm, *Spodoptera eridania*. *Oecologia*, 34, 143-155.
- Scriber, J.M., 1981. Sequential diets metabolic costs and growth of *Spodoptera eridania* (Lepidoptera: noctuidae) feeding upon dill, lima bean, and cabbage. *Oecologia*, 51(2), 175-180.
- Stroomberg, G.J., De Knecht, J.A., Ariese, F, Van Gestel, C.A.M., and Velthorst, N.H., 1999. Pyrene metabolites in the hepatopancreas and gut of the isopod *Porcellio scaber*, a new biomarker for polycyclic aromatic hydrocarbon exposure in terrestrial ecosystems. *Environmental Toxicology and Chemistry*, 18(10), 2217-2224.
- Vetemaa, M., 1997. Chemical industry effluent impacts on reproduction and biochemistry in a North Sea population of viviparous blenny (*Zoarces viviparus*). *Journal of Aquatic Ecosystem Stress and Recocoverly*, 6(1), 33-41.
- Vijayan, M.M. and Moon T.W., 1994. The stress response and the plasma disappearance of corticosteroids and glucose in a marine teleost the sea raven. *Canadian Journal of Zoology*, 72, 379-389.
- Vijayan, M.M. and Moon, T.W., 1992. Acute handling stress alters hepatic glycogen metabolism in food-deprived rainbow trout (*Oncorhynchus mykiss*). *Canadian Journal of Fisheries and Aquatic Science*, 49, 2260-2266.
- Vijayan, M.M., Ballantyne, J.S., and Leatherland, J.F., 1991. Cortisol-induced changes in some aspects of the intermediary metabolism of *Salvelinus fontinalis*, *General and Comparative Endocrinology*, 82, 476-786.
- Waldbauer, G.P., 1968. The consumption and utilization of food by insects. *Advances in Insect Physiology*, 5, 229-288.
- Weber, D. N., 1996. Lead-induced metabolic imbalance and feeding alterations in juvenile fathead minnows (*Pimephales promelas*). *Environmental Toxicology and Water Quality*, 11, 45-51.
- Wootton, R.J., 1990. *Ecology of Teleost Fishes*. Chapman and Hall, Boundary Row, London, pp73-96.
- Yang, R. and Randall, D.J., 1997. Oxygen consumption of juvenile rainbow trout (*Oncorhynchus mykiss*) exposed to sublethal concentrations of 1,2,4,5-tetrachlorobenzene and tetracholorogualacol. *Bulletin of Environmental Contamination and Toxicology*, 59, 479-485.