

**MICROBIAL AND INSECT COLONIZATION OF  
DOUGLAS-FIR STUMPS AND ROOTS, WITH SPECIAL REFERENCE TO  
*PHELLINUS WEIRII* (MURR.) GILBERTSON AND  
GLYPHOSATE APPLICATION**

by

**Kevin Wanner**

B.Sc. Honours Biology, University of Victoria, 1990

THESIS SUBMITTED IN PARTIAL FULFILMENT OF  
THE REQUIREMENTS FOR THE DEGREE OF  
MASTER OF PEST MANAGEMENT

in the Department

of

Biological Sciences

© Kevin Wanner 1994

**SIMON FRASER UNIVERSITY**

September 1994

All rights reserved. This work may not be reproduced in whole or part, by photocopy or other means, without permission of the author.

## APPROVAL

Name: **KEVIN A. WANNER**

Degree: **Master of Pest Management**

Title of Thesis:

**MICROBIAL AND INSECT COLONIZATION OF DOUGLAS-FIR STUMPS  
AND ROOTS, WITH SPECIAL REFERENCE TO PHELLINUS WEIRII  
(MURR.) GILBERTSON AND GLYPHOSATE APPLICATION**

Examining Committee:

Chair: **Dr. A. Harestad, Associate Professor**

---

**Dr. Z. Punja, Associate Professor, Senior Supervisor,  
Department of Biological Sciences, SFU**

---

**Dr. J. Borden, Professor,  
Department of Biological Sciences, SFU**

---

**Dr. J. Rahe, Professor  
Department of Biological Sciences  
Public Examiner**

Date Approved Sept. 2, 1994

PARTIAL COPYRIGHT LICENSE

I hereby grant to Simon Fraser University the right to lend my thesis, project or extended essay (the title of which is shown below) to users of the Simon Fraser University Library, and to make partial or single copies only for such users or in response to a request from the library of any other university, or other educational institution, on its own behalf or for one of its users. I further agree that permission for multiple copying of this work for scholarly purposes may be granted by me or the Dean of Graduate Studies. It is understood that copying or publication of this work for financial gain shall not be allowed without my written permission.

Title of Thesis/Project/Extended Essay

Microbial and Insect Colonization of Douglas-Fir Stumps and Roots,

With Special Reference to Phellinus Weirii (Murr.) Gilbertson and

Glyphosate Application

Author: \_\_\_\_\_

(signature)

Kevin Wanner

(name)

Aug. 18 / 74

(date)

## ABSTRACT

Laminated root rot, caused by *Phellinus weirii*, is one of the most serious diseases of Douglas-fir in the Pacific Northwest. Since *P. weirii* is a poor saprophytic competitor, prior colonization of cut stumps by fungi could render the substrate unsuitable for colonization by the pathogen. The hypothesis that primary colonization of Douglas-fir stumps by saprophytic fungi would be greater when stumps were treated with the herbicide glyphosate was tested. At sites near Mesachie Lake and Maple Ridge, British Columbia, freshly cut stumps of 20 year-old Douglas-fir trees were treated with glyphosate at doses of 2.7 g a.i. and 13.7 g a.i. per stump, respectively. Stain fungi (*Ceratocystis* spp. and *Leptographium wageneri*) were the primary fungal colonizers of Douglas-fir stump roots sampled 6, 10.5 and 14 months after felling. Colonization by stain fungi was associated with the activity of root feeding bark beetles (*Hylastes nigrinus*) and weevils (*Steremnius carinatus*). The frequency of *Ceratocystis* spp. and *L. wageneri* was not different between control and treated stumps at all sampling dates. The proportion of sapwood samples colonized by stain fungi ranged from 31 to 92% and 45 to 92% at 6 and 14 months, respectively, after treatment at the Mesachie Lake site, and 33 to 100% at 10.5 months after treatment at the Maple Ridge site. The results from this study indicate that freshly cut Douglas-fir stumps are extensively colonized by stain fungi 6 to 14 months after felling due to the activity of associated root feeding bark beetles and weevils.

## ACKNOWLEDGEMENTS

I would like to acknowledge the academic and financial support given by Z.K. Punja and J.H. Borden. Work conducted on this thesis was funded by the B.C. Ministry of Forests, Vancouver Region, Science Council of B.C. and Canadian Pacific Forest Products Ltd. Thanks to all the people who reviewed and critiqued work done in this thesis: J. Fournier, J. Beale, G. Fraser, D. Morrison, G. Reynolds, R. Sturrock, E. Nelson, W. Thies and D. Goheen. Thanks to Dee-Ann and Dan for work conducted on glyphosate translocation in my absence. I would like to especially thank family and friends for support during the completion of this thesis.

## TABLE OF CONTENTS

<b>Abstract</b>	<b>iii</b>	
<b>Acknowledgements</b>	<b>iv</b>	
<b>List of Tables</b>	<b>vi</b>	
<b>List of Figures</b>	<b>viii</b>	
<b>Chapter I - Literature Review</b>	<b>1</b>	
1.0 Introduction		1
1.1 Symptoms and Signs of Disease		2
1.2 Damage to Douglas-fir		3
1.3 Survival of <i>Phellinus weirii</i>		4
1.4 Infection and Spread		5
1.5 Management of Disease		7
1.6 Research on Direct Control		9
1.7 Wood Colonization by Microbes and Bark Colonization by Insects		10
1.8 Role of Glyphosate		12
1.9 Objectives		14
<b>Chapter II - Materials and Methods</b>	<b>15</b>	
2.0 Experimental Treatments		15
2.1 Fungal Colonization		16
2.2 Fungal Identification		17
2.3 Insect Infestation		23
2.4 Translocation of Glyphosate		23
2.5 Analysis of Data		24
<b>Chapter III - Results</b>	<b>25</b>	
3.0 Insect and Fungal Infestations on Uninfected Control and Glyphosate-Treated Stumps		25
3.1 Fungal and Insect Infestations on <i>Phellinus weirii</i> Infected Control and Treated Stumps; 12-month Sampling Date		36
3.2 Glyphosate Translocation		46
<b>Chapter IV - Discussion</b>	<b>52</b>	
<b>Literature Cited</b>	<b>65</b>	

## LIST OF TABLES

Table 1	Fungal colonization of 54 phloem and 54 sapwood samples per stump from three uninfected control and four glyphosate-treated Douglas-fir stumps from Mesachie Lake six months after application of glyphosate. Unidentified isolates include those lost due to contamination. Data from two control stumps not attacked by bark beetles was deleted.	27
Table 2	Fungal colonization of four uninfected control and four glyphosate-treated Douglas-fir stumps 14 months after application of glyphosate.	29
Table 3	Colonization of uninfected treated and control stump roots by larval <i>Hylastes nigrinus</i> and <i>Steremnius carinatus</i> 14 months after treatment with glyphosate. Pooled root disks from five control and five treated stumps ranked into classes of increasing phloem colonization.	32
Table 4	Fungal colonization of four uninfected control and four glyphosate-treated Douglas-fir stumps sampled 10.5 months after application of glyphosate at the Malcolm Knapp Research Forest.	34
Table 5	Colonization of uninfected control and treated stump roots by larval <i>Hylastes nigrinus</i> and <i>Steremnius carinatus</i> 10.5 months after application of glyphosate at the Malcolm Knapp Research Forest. Pooled root disks from four control and four treated stumps ranked into classes of increasing phloem colonization by beetle larvae.	37
Table 6	Microbial colonization of decayed and nondecayed sapwood from the roots of three trees exhibiting early symptoms and five trees showing advanced symptoms of <i>Phellinus weirii</i> infection. Infection of root systems by <i>Phellinus weirii</i> was estimated as the proportion of total root disk surface area. Isolates from one early symptomatic tree were omitted due to contamination. Because of the low number of samples and replicates, n = total number of samples pooled from the three early and five advanced symptomatic trees.	39
Table 7	Microorganisms isolated from <i>Phellinus weirii</i> -decayed sapwood samples pooled from three early and five advanced symptomatic trees, in relation to decay type and distance from the root collar.	42

Table 8	Microbial colonization of two control and two glyphosate-treated stumps, cut 12 months earlier. Infection by <i>Phellinus weirii</i> was estimated as the proportion of total root disk surface area. Due to the low number of replicates, data for isolates from the two control (early symptomatic) and treated (advanced symptomatic) stumps were pooled.	44
Table 9	Microorganisms isolated from <i>Phellinus weirii</i> -decayed sapwood samples pooled from four stumps cut 12 months earlier in relation to decay type and distance from the root collar.	47
Table 10	Frequency of four levels of radioactivity in root samples from one Douglas-fir seedling treated in March of 1992 and three seedlings treated in May of 1994, 76 h after treatment of their cut stems with a 4 uCi dose of <sup>14</sup> C-glyphosate. Root samples in May of 1994 were assayed for radioactivity using two techniques: sample combustion and liquid scintillation spectrometry or extraction in 95% ethanol and liquid scintillation spectrometry.	50



## LIST OF FIGURES

- Figure 1      Sampling technique in which four roots per stump were hand excavated and cross sectional root disks cut at 20, 60 and 100 cm from the root collar.      18
- Figure 2      Root disk sampling protocol. **A)** During the six-month Mesachie Lake sampling, root disks were split into six wedges. From each wedge a portion of the outer annual ring was aseptically split off, and a 2 mm sapwood chip was cut. Malt agar petri plates were numbered 1-6 in a clockwise direction to correspond to the location of the cut chip. **B)** During all subsequent sampling dates, root disks were split into three triangular wedges, each of which was split twice more (two annual rings deep and halfway to the disk centre) tangentially to the annual rings. In this way, three sapwood chips (#1-3) could be sampled from outer annual rings and three (#4-6) from inner annual rings, and transferred to malt agar medium.      20
- Figure 3      Hypothetical succession of *Phellinus weirii* inoculum in infected 20 year old Douglas-fir trees. As trees progress from early to advanced symptom stages, *Phellinus weirii* colonizes the root system in the absence of saprophytic fungi. When trees decline to the point where they can no longer resist saprophytic colonization, *Phellinus weirii* has brought the majority of the root system to an advanced stage, and the inoculum deteriorates naturally.      59
- Figure 4      Hypothetical succession of *Phellinus weirii* inoculum in infected 20 year old Douglas-fir trees which have been cut at an early symptom stage. At early symptomatic stages, approximately 30% of the root system volume has been infected. Assuming that approximately two-thirds of decay at early symptom stages is incipient, of the 30% decay, 20% will be incipient and 10% advanced. Since incipient decay may be more susceptible to colonization by saprophytic fungi, which gain entry when the infected tree is cut, the natural decline of inoculum may be accelerated. The 10% advanced decay deteriorates naturally. Alternatively, if early symptomatic trees are not cut, inoculum levels, mainly composed of advanced decay, reach 75 - 90% of the root system volume.      62

## CHAPTER I - LITERATURE REVIEW

### 1.0 INTRODUCTION

*Phellinus weirii* (Murr.) Gilbertson (Aphyllophorales: Hymenochaetaceae) is a fungal pathogen which causes laminated root rot of Douglas-fir, *Pseudotsuga menziesii* (Mirb.) Franco. Laminated root rot was first reported in British Columbia in 1929 in samples from Cowichan Lake (Mounce *et al.* 1940). *Poria weirii* (Murr.), previously described as causing a butt rot of western redcedar (*Thuja plicata* Donn) was demonstrated to be the causal agent of laminated root rot of Douglas-fir, based on similar symptoms and fungal morphology (Mounce *et al.* 1940). Gilbertson (1974) reassigned the pathogen to the genus *Phellinus*.

Two varieties of *P. weirii* have been described. The redcedar variety causes butt rot in western redcedar (Morrison *et al.* 1991), while the Douglas-fir variety infects the roots of fir (*Abies* Mill. spp.), hemlock (*Tsuga* [Endl.] Carr. spp.), spruce (*Picea* A. Dietr. spp.) and western larch (*Larix occidentalis* Nutt.) (Thies 1984). Banik *et al.* (1993) found substantial serological differences between isolates of the two varieties from Washington, Oregon, Idaho and British Columbia. In B.C., *P. weirii* is found west of the Rocky Mountains and as far north as Williams Lake (Morrison *et al.* 1991). Douglas-fir is the predominant and most susceptible host of *P. weirii*. Lodgepole pine, *Pinus contorta* Dougl., and western white pine, *Pinus monticola* Dougl., are tolerant to the pathogen, while ponderosa pine, *Pinus ponderosa* Laws., and western redcedar appear to be resistant. Hardwood trees are non-hosts (Thies 1984).

## 1.1 Symptoms and Signs of Disease

Progressive symptoms of laminated root rot are: reduced terminal growth, yellowing of the foliage, thinning of the crown, possible stress cone crop and finally death of the tree (Mounce *et al.* 1940). Infected trees do not exhibit crown symptoms until a major portion of the root system has been infected; in large trees this may require 5-15 years after infection (Thies and Nelson 1987). Symptoms may persist for up to 10 years before death (Thies 1984). Extensive terminal growth reduction in large trees gives the crown a rounded appearance. Young trees (5-25 years old) may die soon after infection (Thies 1984).

Since the symptoms of laminated root rot are virtually identical to those of several other biotic and abiotic root diseases, positive identification requires examination of the root collar for signs of *P. weirii*. Infected roots are usually covered with superficial mycelium, grey white to tawny in colour. Often the ectotrophic mycelium is covered by a crust-like mat, especially in the crotches of roots (Thies 1984). The crusty mat produces a distinctive crackling sound when touched. Examination with a hand lens discloses reddish-brown, wiry setal hyphae scattered throughout the ectotrophic mycelium or within advanced decay wood; in combination with decay signs, these hyphae are diagnostic for *P. weirii* (Mounce *et al.* 1940).

In longitudinal section, chocolate-brown streaks or broad bands of incipient decay may be seen along the grain of root or bole sapwood. Crescent-shaped patches or a coalesced ring of decay can be seen in the sapwood on stump surfaces after cutting, but heart wood often remains undecayed (Mounce *et al.* 1940). In advanced stages of decay,

small ovoid pits begin to appear and the wood separates into layers along the annual rings, creating sheets of yellowish, pitted wood, hence the name "laminated root rot" (Mounce *et al.* 1940).

Most researchers isolate *P. weirii* in pure culture by aseptically dissecting decayed wood samples and plating them onto malt agar amended with an antibiotic. Samples originating from advanced decayed wood that are contaminated with secondary fungi can be cultured on media selective for wood rotting Basidiomycetes (Hunt and Cobb 1971) or for *P. weirii* (Hutchinson *et al.* 1985). In culture, *P. weirii* produces a slightly raised, 'wood brown' mat with a cottony to woolly texture. Hyphae are hyaline, thin-walled with simple septae and branch most frequently below a septum. Setal hyphae, slender and tapering to a point, have thick brown walls and are numerous in the mycelial mat (Mounce *et al.* 1940).

## **1.2 Damage to Douglas-fir**

Root sections distal to infection points are girdled and die. As decay of the root system continues, water and nutrients fail to reach the foliage and physical support of the tree is undermined, predisposing it to windthrow (Mounce *et al.* 1940). In 5 to 25 year old stands, damage is localized to infection centres comprised of individual scattered trees or small groups of trees. Infection centres after age 40 are characterized by openings in the stand created by windthrow of infected trees (Thies 1984).

Laminated root rot is one of the most serious diseases of conifers in the Pacific Northwest. Five percent of the forested area in Oregon and Washington is infected

(USDA Forest Service 1985), and annual losses in timber are estimated at 4.4 million m<sup>3</sup> in the Pacific Northwest (Nelson *et al.* 1987). Losses which in B.C. can reach 50% of a stand, are greatest in pure Douglas-fir stands ( Fink *et al.* 1989). The B.C. Ministry of Forests (1986 and 1989) has estimated annual growth losses on Crown land (95% of forest lands in B.C.) to be 859,311 m<sup>3</sup>, approximately 10% of the annual harvest of Douglas-fir in 1989 (8.8 million m<sup>3</sup>). Raw Douglas-fir logs are valued at approximately \$50/m<sup>3</sup> while the total economic yield is estimated at \$200/m<sup>3</sup> (from the Association of B.C. Professional Foresters). Therefore, 859,311 m<sup>3</sup> equates to a potential annual loss of \$43 million in raw logs and \$172 million in total economic benefits.

### 1.3 Survival of *P. weirii*

*Phellinus weirii* can survive in residual stumps for 50-100 years (Hansen 1979). In natural soil, fungal mycelium never grows more than a few centimetres, but growth is not restricted in sterile soil (Wallis 1976). The longevity of inoculum in a stump and root system depends on the food base size, degree of infection, stump age and activity of insects and other fungi (Morrison *et al.* 1991). Viable mycelium progressively retreats inward into the stump as it ages (Hansen 1979).

Zone lines, which are bands of resin soaked wood that can protect against desiccation and fungal invasion, are frequently found surrounding living *P. weirii* in stumps (Hansen 1979; Morrison *et al.* 1991). When wood cubes colonized by *P. weirii* were buried in forest ground, the pathogen survived only in cubes in which zone lines had formed

(Nelson 1964). *P. weirii* was isolated from only one of 64 cubes in which zone lines had not formed since other fungi had colonized decayed wood formerly occupied by *P. weirii* (Nelson 1967). In buried wood cubes containing zone lines, microbial activity apparently caused a decline in survival from 100% after 6 months to 32% after 20 months (Nelson 1964).

#### **1.4 Infection and Spread**

*Phellinus weirii* produces basidiospores but has no asexual spores. Repeated attempts to inoculate healthy trees with basidiospores have failed (Hansen 1986); thus spore dispersal is considered to be rare. Pathogen spread occurs by vegetative growth of mycelium from an inoculum source to a healthy tree root. Since *P. weirii* can only grow through soil for  $\leq 1$  cm, root contact is required for infection. Inoculum can remain in stumps and roots from a previously infected stand or can occur in the roots of living trees. Sapling roots in contact with inoculum from a previous stand can result in generation-to-generation spread for up to 25 years after a stand is established, while root contact between healthy and infected trees initiates spread within the current stand (Wallis and Reynolds 1965).

Due to long-term survival capability in residual stump roots and vegetative spread by root contact, infection centres tend to persist, and laminated root rot is termed a "disease of the site". Nelson and Hartman (1975) photographically compared the same disease

centres in 1946 and 1972, and calculated the expansion of disease centres to average about 34 cm/year.

Mycelium from an inoculum source can spread ectotrophically (on the bark surface) onto adjacent healthy roots and then penetrate the bark to become endotrophic in the root system sapwood. Mycelium was found to advance ectotrophically as far as 200 cm ahead of sapwood decay in 15-45 year old trees (Wallis and Reynolds 1965). Penetration of the bark suggests an ability to overcome the host's passive defense mechanisms (Rishbeth 1972).

Sapwood tissue of trees can react in a nonspecific response to injury or infection by the production of necrotic reaction zones which accumulate inhibitory compounds, such as phenols (Shain 1979). The reaction zone is adjacent to and produced in advance of infection, and is one of the mechanisms involved in the compartmentalization of decay in living trees (Shortle 1979). Another defense mechanism is the formation of wound periderm, a nonspecific meristematic response to injury or infection that can isolate slowly growing parasites (Rishbeth 1972; Biggs *et al.* 1984 ).

A general strategy of some root-infecting pathogens used to overcome host resistance is ectotrophic growth and penetration simultaneously at several points (Garret 1970). The ectotrophic growth of *P. weirii* allows mass penetration of the bark at several points, leading to rapid colonization of the root system via the root collar and intra-tree root contacts. Penetration of the bark is evidenced by necrotic flecking in the phloem (Wallis and Reynolds 1965). The mechanism by which penetration occurs is unknown.

Investigation of the factors which influence pathogen transmission and infection has utilized inoculation of healthy trees with infested wood blocks and hydraulic excavation of infected root systems. Both techniques have revealed that when healthy uninfected roots contact an inoculum source, successful transfer of ectotrophic mycelium occurs frequently. However, when these roots were dissected, successful infection of the sapwood was found to be much less frequent (Wallis and Reynolds 1962, 1965). Observations of naturally and artificially infected roots demonstrated that penetration of large roots was slow, probably due to bark thickness (Bloomberg and Reynolds 1982).

Wallis and Reynolds (1965) inoculated the roots of variably aged Douglas-fir stumps with artificial inoculum blocks. Although ectotrophic growth was not affected, the success of endotrophic infection decreased with stump age, with 8/10, 5/11 and 2/11 roots infected for stumps aged 3, 6 and 12 months, respectively, after felling. Wallis and Reynolds (1965) hypothesized that initial microbial colonizers of stump roots may have inhibited endotrophic infection.

### **1.5 Management of Disease**

Treatment of *P. weirii* infested stands to control disease was infrequent prior to 1980. Increased awareness of the disease, timber shortages, and legislation requiring the recognition and management of pests, such as *P. weirii*, on Crown land have led to more active management strategies (Beale 1987).



Management strategies have focused on reducing inoculum before planting harvested sites with a susceptible species. Rotation with resistant tree species may provide time for *P. weirii* inoculum levels to decline naturally. However, western white pine seedlings resistant to white pine blister rust are not yet available and western redcedar is not silviculturally suited to all infected sites. Mechanical stump and root removal can allow susceptible species such as Douglas-fir to be replanted on infected sites. However, stump removal causes significant site disturbance and may cost \$800 to \$1,300/ha (Beale 1987).

There are many areas in B.C. where only Douglas-fir has been planted on harvested sites previously infested with *P. weirii*. Such a practice can result in losses of 50-90% in second and third rotations (Thies 1984). Currently, no strategies for managing laminated root rot in second-growth Douglas-fir are operational. It has been suggested that separating inoculum sources from uninfected trees by removing "bridge trees" in second growth stands could reduce losses (USDA Forest Service 1985; Beale 1987; B.C. Ministry of Forests 1989). Bridge trees grow adjacent to an infection centre; their roots, if colonized by the pathogen, could serve as a bridge to nearby trees. In practice, a survey contractor would mark disease centres and during spacing operations, crews would remove all susceptible conifers within the infection centre and bridge trees over a 5 m buffer zone surrounding the infection centre (British Columbia Ministry of Forests 1989).

## 1.6 Research on Direct Control

Research into direct control of laminated root rot has concentrated mainly on reducing pathogen survival in cut stumps after harvesting. Thies and Nelson (1982, 1987) found that the fumigant Vorlex (a.i. methylisothiocyanate) injected into infected stumps through drilled holes (1.5 g a.i. per kg of stump biomass), killed *P. weirii*. Survival of *P. weirii* 20 months after treatment (determined as viable mycelium isolated onto 1.5% malt agar) was 22% of prefumigation inoculum levels, as measured in control stumps (Thies and Nelson 1987). However, the effectiveness of fumigation decreased with increasing stump size, and diffusion of the chemical appeared to be restricted by decayed wood (Thies and Nelson 1982). Other drawbacks of fumigating stumps included the high treatment dose required (0.418 kg a.i. for a 60 cm diameter stump) and persistence of the highly toxic fumigant for up to 20 months (Thies and Nelson 1987).

*Trichoderma viride* Pers. was isolated from 10% of root disks sampled from stumps fumigated two years previously with chloropicrin and Vorlex (Nelson *et al.* 1987). Among 70 isolates representing six species of *Trichoderma*, obtained from *P. weirii*-infected Douglas-fir stumps, isolates of *T. viride*, *T. polysporum* (Link) Rifai and *T. harzianum* (Bon.) Bain were the quickest to overgrow and kill *P. weirii* on malt agar plates at 20 ° C (Goldfarb *et al.* 1989a, 1989b). To test whether *P. weirii* could be displaced by *T. viride*, infected stumps were inoculated with dowels or granular pellets colonized by *T. viride* (Nelson and Thies 1985, 1986). After one year, *T. viride* had

colonized stump tissue 6 cm from the inoculation points. However, colonization was not fast or complete enough to displace *P. weirii* (Nelson and Thies 1985, 1986).

### **1.7 Wood Colonization by Microbes and Bark Colonization by Insects**

The degree of insect and fungal colonization of wood has been well characterized for above ground wood represented by tree boles and branches, but there is very little information available for colonization of wood in stumps and roots.

Most of conifer wood is composed of secondary xylem trachieds which lack cellular contents and are nutrient poor, while phloem, cambium and parenchyma tissues in the wood are rich in carbohydrates and proteins. Parenchyma, phloem and cambium are living tissues with primary cell walls, while xylem trachieds are non-living and have primary and secondary cell walls.

Insects and fungi employ two main strategies of wood utilization: exploiting the easily assimilated energy within living cells, and extraction of the energy bound in cellulose, hemicellulose and lignin of the trachied or vessel element cell walls (Swift and Boddy 1984). The former strategy is utilized by bark beetles and weevils, bacteria, molds and stain fungi, while soft rot Ascomycetes and Fungi Imperfecti, and brown and white rot Basidiomycetes, decompose lignin, hemicellulose and cellulose (Liese 1970).

Bark beetles (Coleoptera:Scolytidae) make up the majority of colonizers of dying or stressed trees (Harmon *et al.* 1986). Adult bark beetles bore through the outer bark and construct egg galleries in living phloem tissue where the larvae feed. Many of these beetles

depend on specific fungal associates to kill or condition the host (Berryman 1989). This relationship involves specialized mycangia which harbour the fungal inocula (Swift and Boddy 1984). However, inoculum dispersal can be passive, with fungal propagules found on any part of the beetle's body or in its frass. Fungal associates of bark beetles gain access to fresh, relatively sterile food sources. Through the beetle's vectorship, they also bypass defenses such as tannins in bark cork cells that precipitate microbial produced enzymes (Dowding 1984).

Many fungal associates of bark beetles are imperfect stages of *Ceratocystis* spp. These stain fungi invade phloem, cambium and parenchyma cells and grow very quickly through the sapwood via parenchyma ray systems. Hyphae also move through trachieds via pit apertures (Liese 1970). Rapid growth, 3 mm/day radially and 10 mm/day longitudinally, in conifer wood allows these fungi to dominate the sapwood. Their profuse mycelium produces a distinctive discoloration, usually appearing blue, gray, pink or brown (Dowding 1984).

Weevils (Coleoptera:Curculionidae) can attack the roots and stem bases of healthy trees but most frequently attack weakened trees and stumps. Like bark beetles, the adults and larvae feed on the phloem tissue and first annual ring of the sapwood (Dowding 1984).

## 1.8 Role of Glyphosate

Glyphosate (N-[phosphonomethyl]glycine) is the active ingredient of Vision, a herbicide formulation commonly used for silvicultural weed control. In higher plants, glyphosate is highly mobile in both the symplast and apoplast. Translocation occurs through the vascular system as well as by cell-to-cell transport (Casely and Coupland 1985). Structurally similar to a number of phosphorylated metabolites, glyphosate exhibits typical 'source-to-sink' transport in the phloem (Casely and Coupland 1985).

Glyphosate is registered for the control of stump suckering after hardwoods are cut as well as for the control of hardwoods and conifers (*Pseudotsuga*, *Pinus*, *Picea*, *Tsuga* and *Thuja* species) by stem injection (Ezject Supplemental Label - 1991, Pesticide Control Product # 21262). Control of suckering with stump applied glyphosate (Johansson 1985) provides indirect evidence for its translocation to and killing of the roots.

Translocation of glyphosate has been investigated in deciduous and conifer seedlings by applying <sup>14</sup>C-glyphosate to leaves and sampling representative plant tissues for radioactivity. When <sup>14</sup>C-glyphosate was applied to the needles of 10 week old and 1 year old loblolly pine, *Pinus taeda* L., < 10% of the absorbed glyphosate was translocated to the roots (D'Anieri 1990; Green *et al.* 1992). The majority of <sup>14</sup>C-glyphosate remained in the needles and it was concluded that symplastic entry was the key barrier to translocation (D'Anieri 1990). Application of <sup>14</sup>C-glyphosate to the stems of birch seedlings increased uptake from 20% (with leaf application) to 80% (Lund-Hoie 1979).

The primary mode of action of glyphosate is the competitive inhibition of the shikimic acid pathway enzyme, 5-enolpyruvylshikimate-3-phosphate (EPSP) synthase (Cole 1985). All aromatic compounds involved in primary metabolism of plants are synthesized by the shikimic acid pathway. Deficiencies in aromatic amino acids, specifically phenylalanine, tyrosine and tryptophan, inhibit protein synthesis and secondary compound formation (Coggins 1989).

One of the proposed mechanisms by which glyphosate-treated herbaceous plants are killed is through enhanced fungal colonization resulting from inhibition of secondary compound formation involved in defenses against microorganisms (Rahe *et al.* 1990). Mortality of bean seedlings treated with small quantities of glyphosate was due to enhanced colonization of the roots by pathogenic *Pythium* and *Fusarium* spp. (Rahe *et al.* 1990). Similarly, tomato seedlings treated with sublethal doses of glyphosate were colonized by *Fusarium* spp. (Brammall and Higgins 1988). *Pythium*, *Fusarium* and *Cylindrocarpon* spp. were the predominant fungal colonizers of apple seedlings treated with glyphosate (Levesque and Rahe 1992). *Pythium* and *Fusarium* spp. isolated from glyphosate-treated apple seedlings decreased LD<sub>50</sub> values of glyphosate applied to McIntosh apple seedlings (Levesque and Rahe 1992). Sublethal glyphosate doses applied to white birch, *Betula papyrifera* (Marsh.), seedlings significantly increased levels of shikimic acid (EPSP synthase substrate) long before visual injury was observed (Stasiak *et al.* 1992).

The above observations led to the hypothesis that treating the phloem and xylem tissue of freshly cut Douglas-fir stumps with glyphosate could enhance colonization of stump root systems by fungal decomposers found naturally in the surrounding soil. Since *P. weirii* is believed to be a poor saprophytic competitor, fungal colonization of stump sapwood could exclude or reduce its growth capability within host tissues. Therefore, the application of glyphosate could be used as a disease control tactic for laminated root rot.

## 1.9 OBJECTIVES

The experimental objectives were to:

1. Characterize the effect of glyphosate, applied to the stumps of noninfected Douglas-firs, on the extent of colonization of the root system by saprophytic fungi;
2. Characterize the effect of glyphosate, applied to the stumps of infected Douglas-firs, on the extent of colonization of the root system by saprophytic fungi and by *P. weirii*;
3. Demonstrate the extent of translocation of glyphosate from a cut stem surface throughout the root system, and;
4. Identify fungal isolates to genus (and species if possible) and to determine whether glyphosate treatment affects the composition or succession of fungal colonization of infected and uninfected Douglas-fir stump root systems.

## CHAPTER II - MATERIALS AND METHODS

### 2.0 Experimental Treatments

**Mesachie Lake:** A stand of Douglas-fir, planted in 1969, was selected 10 km southwest of Mesachie Lake, B.C. Twenty uninfected trees and 10 trees infected by *P. weirii* were chosen at 10 m intervals along parallel transects approximately 20 m apart. Infected trees exhibited above ground symptoms and ectotrophic mycelium at the root collar. Uninfected trees lacked both these characters. Selected trees had a diameter ( $\bar{x} \pm \text{S.D.}$ ) at breast height (dbh = 1.3 m) of  $15.2 \pm 1.5$  cm.

The trees were delineated into five randomized blocks, each with four uninfected and two infected trees. The trees were felled on 16 May, 1991. Immediately after felling, treated stumps were sprayed with approximately 75 mL of 10% Vision in distilled water (2.7 g a.i.). Control stumps received 75 mL of water.

Six and 14 months after treatment (12-14 November, 1991 and 11-12 July, 1992, respectively), five uninfected control stumps and five uninfected treated stumps were excavated with hand tools and assessed for degree of fungal colonization. To determine the extent of indigenous fungi, the root systems of four uninfected standing trees were also excavated at the six-month sampling. Infected control and treated stumps were excavated and sampled 10-11 May, 1992, 12 months after treatment, but only two control and two treated stumps were actually found to be infected. For comparison, the root systems of eight infected standing trees were also sampled, three in early and five in advanced symptomatic stages. Early symptomatic trees exhibited reduced terminal growth with



green to yellow-green foliage, while advanced symptomatic trees were characterized by severely reduced terminal growth and yellow foliage.

**Malcolm Knapp Research Forest:** A stand of second growth Douglas-fir, 20 years old, was selected at the University of B.C. Malcolm Knapp Research Forest in Maple Ridge, B.C. Ten groups of trees, approximately 20 m apart, five trees in each group, were marked and delineated into five paired blocks. The average dbh ( $\bar{x} \pm \text{S.D.}$ ) was  $16.8 \pm 5.0$  cm.

On 2 April, 1992, all trees were felled. Immediately after felling, treatments consisting of 100 mL of 38.5% Vision in distilled water (13.7 g a.i.) were randomly applied to the stumps of one group within each paired block, resulting in five paired blocks.

One treated and one control stump was sampled from each of four blocks 10.5 months after treatment (12-14 February, 1993), and the degree of root colonization by fungi and insects was assessed.

## **2.1 Fungal Colonization**

Cross sectional disks were cut at distances of 0.2, 0.6, and 1.0 m from the root collar (Fig. 1) from four excavated roots of each stump. The root disks were washed in the laboratory, surface sterilized in 10% bleach (Javex, 6.25% NaOCl) for 10 min and aseptically subsampled in a laminar flow hood. The bark was peeled off and the disks were split into sections. For Mesachie Lake six-month sampling (Fig. 2A), the disks were split into six wedges. A sapwood chip was sampled from the outer annual rings of each wedge after the outer annual ring was aseptically removed to eliminate the influence of the

phloem/sapwood interface. Six phloem chips were also sampled from the inner bark surface outside of each wedge. During all subsequent sampling (Fig.2B), disks were split into three wedges, which were each split twice tangentially to the annual rings in order to sample three sapwood chips from the outer annual rings and three at points halfway to the disk centre; phloem chips from the inner bark were not sampled. Sapwood chips were plated onto malt agar (Difco) amended with 300 mg/L penicillin. When decay was visible on the surface of disks, the infected area and the location of sampled chips was drawn on a clear transparent sheet overlaid on the decayed area. The sketch was then traced onto graph paper to estimate the extent of decay, calculated as the percentage of total cross-sectional disk area occupied by decay. Decayed areas on the ends of 5 cm long disks was usually symmetrical since decay followed the sapwood grain.

**2.2 Fungal Identification:** Fungi usually grew from the sapwood chips within 5-10 days after plating and incubation in the dark at 24 to 28° C. Over the next 20-30 days, isolates were transferred to potato dextrose agar (Difco) slant tubes for long-term storage and identification. *Phellinus weirii* was identified by the characteristic production of setal hyphae (Mounce *et al.* 1940) and by comparison with type cultures received from the Pacific Forestry Centre, Victoria, B.C. The following characters were used to identify *Ceratocystis* spp.: typical staining and rapid growth in sapwood tissue (Dowding 1984), colony morphology on artificial media, resistance to cycloheximide (Harrington 1981), and imperfect conidial states formed on artificial media and sterilized wood blocks. Conidial state identification followed Upadhyay's (1981) classification by conidia development and

**Figure 1.** Sampling technique in which four roots per stump were hand excavated and cross sectional root disks cut at 20, 60 and 100 cm from the root collar.

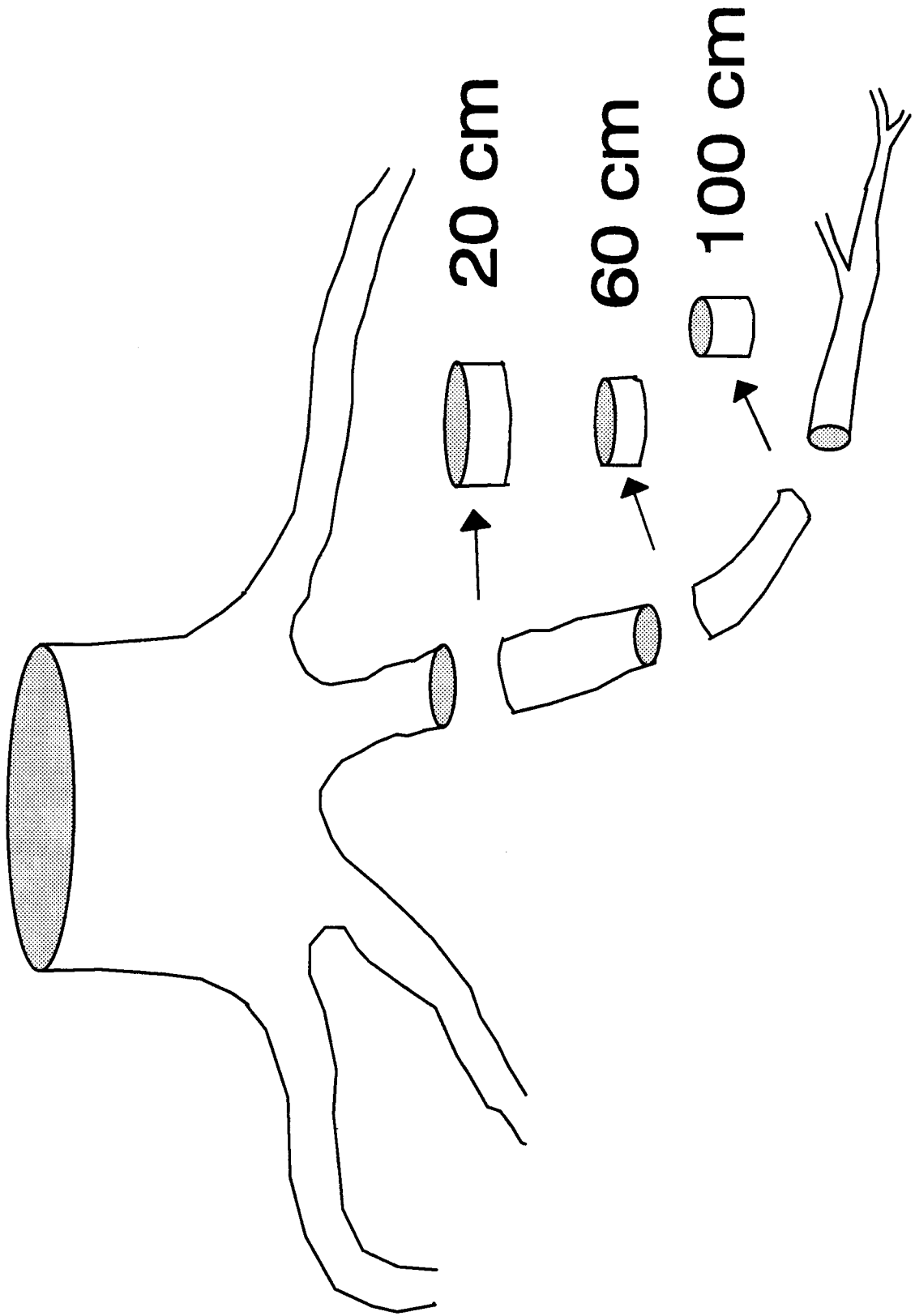

**Figure 2.** Root disk sampling protocol. **A)** During the six-month Mesachie Lake sampling, root disks were split into six wedges. From each wedge a portion of the outer annual ring was aseptically split off, and a 2 mm sapwood chip was cut. Malt agar petri plates were numbered 1-6 in a clockwise direction to correspond to the location of the cut chip. **B)** During all subsequent sampling dates, root disks were split into three triangular wedges, each of which was split twice more (two annual rings deep and halfway to the disk centre) tangentially to the annual rings. In this way, three sapwood chips (#1-3) could be sampled from outer annual rings and three (#4-6) from inner annual rings, and transferred to malt agar medium.

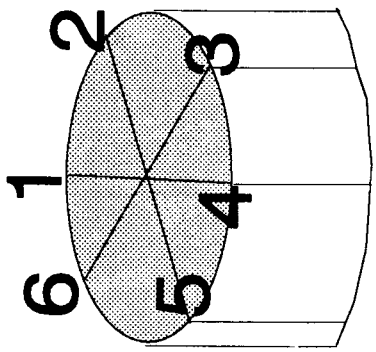

A)

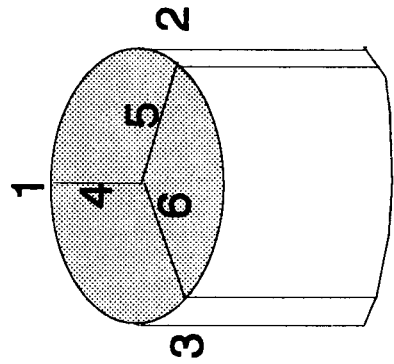
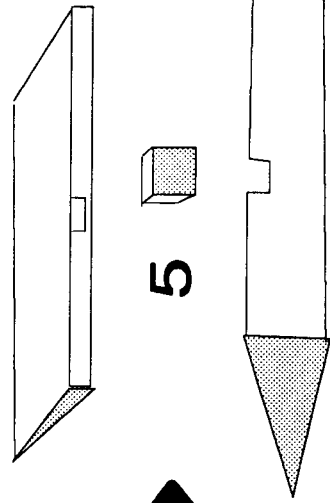
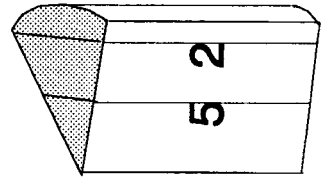
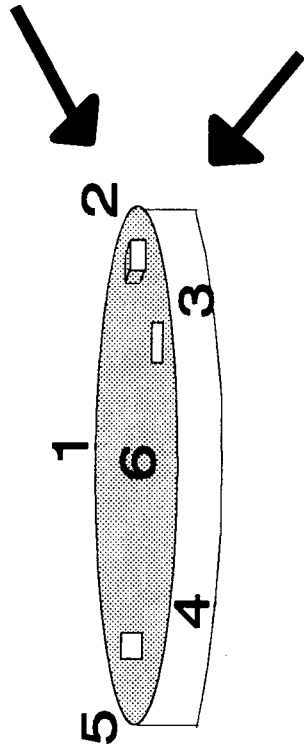
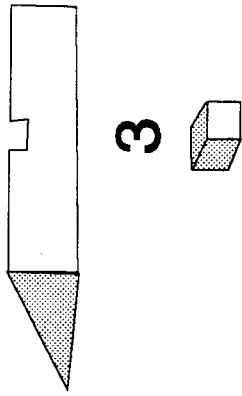
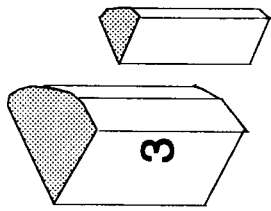

B)

conidiophore structure into the following eight main forms:

<b><u>Conidial State</u></b>	<b><u>Conidiophore Development</u></b>	<b><u>Conidiophore Structure</u></b>	<b><u>Pigmentation</u></b>
<i>Verticicladiella</i>	Sympodial	Mononematous	Dark
<i>Leptographium</i>	Annelidic	Mononematous	Dark
<i>Phialocephala</i>	Phialidic	Mononematous	Dark
<i>Graphium</i>	Annelidic	Synnematous	Dark
<i>Pesotum</i>	Sympodial	Synnematous	Dark
<i>Phialographium</i>	Phialidic	Synnematous	Dark
<i>Graphilbum</i>	Annelidic	Synnematous	Hyaline
<i>Hyalopesotum</i>	Sympodial	Synnematous	Hyaline

*Leptographium wagneri* (Kendr.) Wingf. was identified using the following characters: dark 'chaetura black' colony morphology, large characteristic conidiophores centrally located, large sporogenous apparatus with 5-9 metulae, numerous and crowded sympodulae and obovoid, smooth-walled sympoconidia truncate at the base, slow growth on malt agar but rapid growth on PDA, and the production of small aberrant conidiophores on malt agar which are virtually absent on PDA (Kendrick 1962). *L. wagneri*, the causal agent of black stain root disease, has three host specific varieties:

*wagneri* specific to pinyon pine; *pseudotsugae* specific to Douglas-fir; and *ponderosum* specific to ponderosa, Jeffrey and lodgepole pines.

### **2.3 Insect Infestation**

At the 14-month Mesachie Lake and 10.5 month Malcolm Knapp Research Forest sampling of uninfected treated and control stumps, the degree of attack by root-feeding Coleoptera (Scolytidae and Curculionidae) was assessed. Root disks were visually rated by the area of phloem tissue colonized (Tables 3, 5). Complete utilization of the phloem tissue (Class 5), caused the bark to crumble. Adult insects, but not larvae, were collected from dissected root disks, and were identified by R. Duncan, Pacific Forestry Centre, Victoria, B.C.

### **2.4 Translocation of Glyphosate**

On 9 March, 1992, a 4 uCi dose of  $^{14}\text{C}$ -glyphosate (Amersham Inc., 98.9% pure) was applied to the freshly cut, 2 to 3 cm high, stem surface of a three year old Douglas-fir seedling situated in a fume hood; 76 h after application, 27 root samples, ranging in weight from 0.02 to 0.30 g, were cut at random. Root samples were ground in a mortar and pestle with 2-3 ml of 95% ethanol, topped up with scintillation fluid, and the radioactivity was assayed in a scintillation counter. Five root samples from a single untreated Douglas-fir seedling were similarly assayed. The above experiment was repeated in May of 1994 using three Douglas-fir seedlings. Eight root samples were cut from each of three



seedlings, half of the root samples from each seedling were assayed for radioactivity as described above and half by sample combustion and liquid scintillation spectrometry. Both in 1992 and 1994, seedlings were potted and maintained outdoors and at the time of treatment new foliage was actively flushing.

## **2.5 Analysis of Data**

The SAS statistical package was used to analyze data. Mean fungal frequencies were compared by ANOVA and Duncan's multiple range test, mean decay by Student's t-test, and fungal and insect frequency distributions by Chi-square analysis. In all cases  $\alpha = 0.05$ . Fungal colonization of eight infected trees and four infected stumps was considered a preliminary description. Fungal colonization in two different formats was statistically analyzed by Chi-square analysis.

Zar (1984) recommends that no more than 20% of expected frequencies in Chi-square contingency analyses be less than 5.0. For analyses in this thesis, the Chi-square test is considered to be robust to this rule. In cases where this rule is violated, the number of expected frequencies less than 5.0 are given.

## CHAPTER III - RESULTS

### 3.0 Insect and Fungal Infestations on Uninfected Control and Glyphosate Treated Stumps

#### Mesachie Lake - Six-month Sampling Date

Fungal colonization of the 108 samples (54 sapwood and 54 phloem) taken from each of four standing uninfected trees was 1.9, 0.9, 0.0 and 0.0%, respectively, indicating very low colonization of living roots by indigenous or contaminating fungi. Bacterial and yeast contamination of chips also was very low, in three cases, 0.0, 1.0, 6.0 and moderate in the fourth, 33.0%.

Stump root systems were colonized by root-feeding beetles, primarily the Douglas-fir root beetle, *Hylastes nigrinus* (Mann.). Bark beetles successfully colonized all five glyphosate-treated, and three of five control, uninfected stumps. Egg galleries and larval feeding galleries were observed in the phloem. The phloem and outer sapwood surface of roots colonized by beetles was stained brown and pink. None of 42 phloem and 42 sapwood samples from one control stump not attacked by bark beetles was colonized by fungi. In the other unattacked control stump, only one of 60 phloem and one of 60 sapwood samples were colonized. Fungal colonization of stumps which were successfully attacked by beetles ranged from 31 to 92% of the sapwood and 31 to 73 % of the phloem samples plated per stump.

*Leptographium wagneri* and *Ceratocystis* spp. were identified as primary stump colonizers. *Ceratocystis* isolates were separated into brown and white colony groups,

possibly representing separate species. Both groups produced synnematous conidiophores and annellidic conidia; the brown isolates had darkly pigmented stalks (*Graphium* type) and the white isolates had hyaline stalks (*Graphilbum* type). The predominant colonizer was *Ceratocystis* spp. 'brown type', followed by *Ceratocystis* spp. 'white type' and *L. wagneri* (Table 1), ANOVA,  $P < 0.001$ . The mean percentages of fungal colonization between control and treated stumps and between phloem and sapwood were not significantly different, ANOVA,  $P = 0.63$  and  $0.36$ , respectively.

#### **Mesachie Lake - 14-month Sampling Date**

All of the stumps were successfully colonized by *H. nigrinus* and the Douglas-fir root weevil, *Steremnius carinatus* (Boh). Fungal colonization of root sapwood ranged from 45 to 92% of the chips plated per control stump and 78 to 92% of the chips plated per treated stump (Table 2) (phloem samples were not taken). Frequency of fungal isolation was 81% (97 of 120 samples) from outer sapwood rings and 88% (106 of 120 samples) from inner sapwood rings.

The majority of fungi isolated were *Ceratocystis* spp. All had synnematous conidiophores and annellidic conidia but they could be separated into three groups based upon conidiophore structure and colony morphology: 'white' and

**Table 1.** Fungal colonization of 54 phloem and 54 sapwood samples per stump from three uninfected control and four glyphosate-treated Douglas-fir stumps from Mesachie Lake six months after application of glyphosate. Unidentified isolates include those lost due to contamination. Data from two control stumps not attacked by bark beetles were deleted.

<b>Tissue Source</b>	<b>Fungi Isolated</b>	<b>Control Stumps (%) <math>\bar{x} \pm S.D.^a</math></b>	<b>Treated Stumps (%) <math>\bar{x} \pm S.D.^a</math></b>
<b>Phloem</b>	<i>Ceratocystis</i> 'brown type'	29.5 ±	20.2a ± 7.9a
	<i>Ceratocystis</i> 'white type'	8.1 ±	11.9b ± 12.1b
	<i>Leptographium wageneri</i>	8.2 ±	7.6b ± 3.9b
	Unidentified	7.4 ±	7.5b ± 8.8b
<b>Sapwood</b>	<i>Ceratocystis</i> 'brown type'	38.8 ±	14.1a ± 20.2a
	<i>Ceratocystis</i> 'white type'	11.9 ±	18.6b ± 14.5b
	<i>Leptographium wageneri</i>	11.4 ±	7.9b ± 5.8b
	Unidentified	3.0 ±	3.4b ± 6.2b

<sup>a</sup>Means within a column and tissue followed by the same letter are not significantly different, Duncan's multiple range test,  $P < 0.05$ .

**Table 2.** Fungal colonization of four uninfected control and four glyphosate-treated Douglas-fir stumps 14 months after application of glyphosate.

Fungi Isolated	Control Stumps (%) $\bar{x} \pm$ S.D.	Treated Stumps (%) $\bar{x} \pm$ S.D.
<i>Ceratocystis</i> 'brown type'	27.3 $\pm$	21.0 $\pm$
<i>Ceratocystis</i> 'white type'	23.6 $\pm$	30.7 $\pm$
<i>Ceratocystis</i> 'white/brown type'	14.4 $\pm$	17.1 $\pm$
<i>Ceratocystis</i> spp.	2.8 $\pm$	5.1 $\pm$
<i>Leptographium wagneri</i>	4.7 $\pm$	1.4 $\pm$
<i>Penicillium</i> spp.	0	1.3 $\pm$
Lost - Contamination	3.2 $\pm$	9.4 $\pm$
		11.2

'brown types' as above and a 'white/brown type' with a white colony morphology, grey-brown patches and large hyaline conidiophores (*Graphilbum* type). The remaining isolates were *Ceratocystis spp.*, *Penicillium spp.*, *L. wagneri*, and lost due to contamination (Table 2). The proportions of fungal sapwood colonization between control and treated stumps were not significantly different, ANOVA,  $P = 0.49$ . Mean frequencies of *Ceratocystis* 'brown', 'white', 'white brown type' and the remaining grouped together were not significantly different, ANOVA,  $P = 0.31$ .

The frequency of *L. wagneri* was less than half that in the 6-month samples (Tables 1, 2). One of eight stumps was colonized by an *Armillaria sp.* but cultures from this stump were lost due to mite contamination.

Root disks from five treated stumps were colonized to a significantly greater extent by beetles than root disks from five control stumps (Table 3). Fifty-two adult *H. nigrinus* and 18 adult *S. carinatus* were excised from root disks of treated stumps vs six *H. nigrinus* and three *S. carinatus* from root disks of control stumps.

### **3.01) Malcolm Knapp Research Forest - 10.5-month Sampling Date**

Fungal colonization of root sapwood ranged from 71.4 to 100% in control stumps and 33.3 to 84.8% in treated stumps. One treated stump in which insect colonization was limited to the bole area was colonized 33.3% by fungi.

*Ceratocystis spp.* represented the dominant stump root colonizers (not further separated based upon morphology) followed by *L. wagneri* (Table 4). Three of four control stumps (6 of 37 root disks) were colonized by *Armillaria spp.* while none of the



**Table 3.** Colonization of uninfected treated and control stump roots by larval *Hylastes nigrinus* and *Steremnius carinatus* 14 months after treatment with glyphosate. Pooled root disks from five control and five treated stumps ranked into classes of increasing phloem colonization.

<b>Class</b>	<b>Area of Phloem Occupied</b>	<b>Percent of Control Root Disks (n=32)</b>	<b>Percent of Treated Root Disks (n=36)<sup>a</sup></b>
0	No gallery formation	22	0
1	Single gallery	16	0
2	Single gallery to one-third of phloem area	22	8
3	One-third to two-thirds of phloem area	16	11
4	Two-thirds to all of phloem area	19	42
5	Entire phloem area and loss of bark structure	6	39

<sup>a</sup>Control and treated root disk distributions among beetle colonization classes are significantly different, Chi-square,  $P < 0.001$ , classes 0-1, 2-3, 4-5 pooled.

**Table 4.** Fungal colonization of four uninfected control and four glyphosate-treated Douglas-fir stumps sampled 10.5 months after application of glyphosate at the Malcolm Knapp Research Forest.

Fungi Isolated	Control (%)			Treated (%)		
	$\bar{x}$	$\pm$	S.D. <sup>a</sup>	$\bar{x}$	$\pm$	S.D. <sup>a</sup>
<i>Ceratocystis spp.</i>	58.6	$\pm$	27.5a	41.5	●	29.4a
<i>Leptographium wageneri</i>	25.5	$\pm$	25.7b	27.1	$\pm$	7.4b
<i>Armillaria spp.</i>	2.9	$\pm$	4.5c	0		

<sup>a</sup>Means within a column followed by the same letter are not significantly different, Duncan's multiple range test,  $P < 0.05$ .

four treated stumps (30 disks) was colonized. *Armillaria* spp. extensively colonized the phloem tissue but decay penetrated the sapwood only 1-2 annual rings, resulting in a significantly lower isolation frequency than for the other two isolate types (Table 4). The proportions of fungal colonization between control and treated stumps were not significantly different, ANOVA,  $P = 0.47$ . Mean frequencies of species were significantly different, ANOVA,  $P = 0.001$ .

Root colonization by beetles was low in both control and treated stumps; > 60% of the 39 and 30 root disks from control and treated stumps, respectively, lacked any insect colonization (Table 5). No adult insects and few larvae were found in dissected disks.

### **3.1 Fungal and Insect Infestations on *P. weirii* Infected Control and Treated Stumps - 12-Month Sampling Date**

Percent of the root systems of five advanced symptomatic trees colonized by *P. weirii* averaged  $75.9 \pm 15.5\%$  compared to  $30.5 \pm 17.1\%$  in the roots of four early symptomatic trees. The difference in average decay was significant, t-test,  $P = 0.004$ . Non-decayed root portions from *P. weirii*-infested trees were free of fungal colonizers. Fungi were isolated from none of 80 non-decayed samples from early symptomatic trees and one of 30 non-decayed samples from advanced symptomatic trees (Table 6). Sapwood samples with decay characteristic of *P. weirii* mostly gave rise to pure cultures of *P. weirii* with no contamination. On occasion, other fungi or microbes were associated with *P. weirii* or were found alone. It appeared that these other microorganisms had

**Table 5.** Colonization of uninfected control and treated stump roots by larval *Hylastes nigrinus* and *Steremnius carinatus* 10.5 months after application of glyphosate at the Malcolm Knapp Research Forest. Pooled root disks from four control and four treated stumps ranked into classes of increasing phloem colonization by beetle larvae.

<b>Class</b>	<b>Area of Phloem Occupied</b>	<b>Percent of Control Root Disks (n=39)</b>	<b>Percent of Treated Root Disks (n=30)<sup>a</sup></b>
0	No gallery formation	64	63
1	Single gallery	13	20
2	Single gallery to one-third of phloem area	15	10
3	One-third to two-thirds of phloem area	5	7
4	Two-thirds to all of phloem area	3	0
5	Entire phloem area and loss of bark structure	0	0

<sup>a</sup>Control and treated root disk distributions among beetle colonization classes are not significantly different, Chi-square,  $P = 0.98$ , classes 1-2 and 3-4 pooled. Two of six  $f \leq 5.0$ .

**Table 6.** Microbial colonization of decayed and nondecayed sapwood from the roots of three trees exhibiting early symptoms and five trees showing advanced symptoms of *Phellinus weirii* infection. Infection of root systems by *Phellinus weirii* was estimated as the proportion of total root disk surface area. Isolates from one early symptomatic tree were omitted due to contamination. Because of the low number of samples and replicates, n = total number of samples pooled from the three early and five advanced symptomatic trees.



% Colonization				
Microorganisms Isolated	Early Symtomatic Trees		Advanced Syptomatic Trees	
	Decayed Sapwood (n = 56)	Non- Decayed Sapwood (n = 80)	Decayed Sapwood (n = 158)	Non - Decayed Sapwood (n = 30)
<i>Phellinus weirii</i>	100	0	99.4	0
Black fungus	3.6	0	5.7	0
<i>Ceratocystis</i> spp.	1.8	0	1.9	3.3
Unidentified bacteria and yeast	1.8	0	0.6	3.3
<i>Penicillium</i> spp.	0	0	0.6	0

colonized decayed tissue, and in some cases had displaced *P. weirii*. The majority of these isolates were represented by an unidentified "black" fungus (with a dark morphology in culture), which could not be induced to sporulate (Table 6). The remaining isolates were *Ceratocystis spp.*, *Penicillium spp.* and unidentified bacteria and yeasts (Table 6).

The incidence of isolates other than *P. weirii* from decayed sapwood was not significantly different between three early and five advanced symptomatic trees (7.1 vs 8.9%, respectively), Chi-square test,  $P = 0.69$ ,  $1/4 \hat{f}_i < 5.0$ .

Isolations from decayed sapwood of early and advanced symptomatic trees were pooled and regrouped according to decay type and distance from the root collar (Table 7). The frequencies of isolates found at 20, 60 and 100 cm from the root collar were not significantly different (Chi-square test,  $P = 0.41$ ), nor were the frequencies of isolation from incipient and advanced decayed sapwood (Chi-square test,  $P = 0.78$ ,  $1/4 \hat{f}_i < 5.0$ ).

Of the two control and two glyphosate-treated stumps sampled at Mesachie Lake 12 months after treatment, by chance, the control stumps were from early symptomatic trees and the treated stumps from advanced symptomatic trees as evidenced by respective levels of *P. weirii* infection of  $22.9 \pm 27.2\%$  and  $85.8 \pm 9.5\%$ . *Phellinus weirii* was isolated at similar and not significantly different frequencies (Chi-square test,  $P = 0.31$ ) from the decayed sapwood of treated and control stumps (Table 8). Correspondingly, the frequencies of other isolates combined from treated (13%) and control (20%) stumps were similar (Chi-square test,  $P = 0.40$ ). Non-decayed root tissue from infected stumps was colonized mainly by *Ceratocystis spp.* (Table 8).

**Table 7.** Microorganisms isolated from *Phellinus weirii*-decayed sapwood samples pooled from three early and five advanced symptomatic trees, in relation to decay type and distance from the root collar.

Distance from root collar (cm)	Micro-organisms isolated	Advanced Decay		Incipient Decay		Total Decay	
		No. of Samples	% Colonization	No. of Samples	% Colonization	No. of Samples	% Colonization
20	Black Fungus	12	0.0	89	5.6		
	<i>Ceratocystis</i>	12	0.0	89	2.2		
	Microbe	12	0.0	89	1.1		
	<i>Penicillium</i>	12	8.3	89	0.0	101	8.9
60	Black Fungus	20	0.0	64	4.7		
	<i>Ceratocystis</i>	20	0.0	64	3.1	84	6.0
100	Black Fungus	9	22.2	20	5.0		
	Microbe	9	0.0	20	5.0	29	13.8
All Isolates and Distances Pooled		41	7.7	173	8.7	214	8.4

**Table 8.** Microbial colonization of two control and two glyphosate-treated stumps, cut 12 months earlier. Infection by *Phellinus weirii* was estimated as the proportion of total root disk surface area. Due to the low number of replicates, data for isolates from the two control (early symptomatic) and treated (advanced symptomatic) stumps were pooled.

Micro-organisms isolated	% Colonization			
	Control Trees		Treated Trees	
	Decayed Sapwood (n = 25)	Non-decayed Sapwood (n = 61)	Decayed Sapwood (n = 69)	Non-decayed Sapwood (n = 16)
<i>P. weirii</i>	84.0	0.0	91.3	0.0
Black Fungus	12.0	0.0	7.2	0.0
<i>Ceratocystis</i>	4.0	83.6	0.0	68.8
Microbe	0.0	9.8	4.3	25.0
<i>Penicillium</i>	0.0	3.3	1.5	0.0

Colonization of the phloem tissue by insects was observed only on non-decayed roots. In compiling the data for Table 6, *P. weirii* was successfully isolated from 99.5% of 214 samples, but from four stumps cut 12 months previously (Table 8), *P. weirii* was isolated from 89.4% of 94 decayed sapwood samples. These values are significantly different, Chi-square test,  $P < 0.001$ ,  $1/4 \hat{f}_i < 5.0$  and suggest that *P. weirii* was displaced from 0.5% of the samples from pooled symptomatic trees and 10.6% of the samples from 12 month old stumps.

Microorganisms other than *P. weirii* in the stumps sampled 12 months after cutting were found significantly more frequently from incipient than advanced decay samples (28.6% of 28 samples vs 9.1% of 66 samples, Table 9) (Chi-square test,  $P = 0.02$ ,  $1/4 \hat{f}_i < 5.0$ ). There was no significant difference in frequency of colonization with respect to distance from the root collar ( Chi-square test,  $P = 0.27$ , Table 9 ).

### **3.2 Glyphosate Translocation**

Successful translocation of glyphosate in treated stumps was evidenced in the field by the occurrence of flashback at both Mesachie Lake and the Malcolm Knapp Research Forest. Flashback, presumably by herbicide translocation through root grafts, killed several trees directly adjacent to treated stumps. Newly flushing buds on the neighbouring trees quickly turned brown and the trees died by the end of the field season. Ambrosia beetles (Coleoptera:Scolytidae) rapidly colonized the root collar and lower bole of trees killed by flashback.

Translocation of stump-applied  $^{14}\text{C}$ -glyphosate to the root system of a three year

Table 9. Microorganisms isolated from *Phellinus weirii*-decayed sapwood samples pooled from four stumps cut 12 months earlier in relation to decay type and distance from the root collar.



Distance from root collar (cm)	Micro-organisms isolated	Advanced Decay			Incipient Decay			Total Decay		
		No. of Samples	% Colonization	No. of Samples	% Colonization	No. of Samples	% Colonization	No. of Samples	% Colonization	
20	Black Fungus Microbe	24	0.0	14	14.3	38	7.9			
		24	0.0	14	7.1					
60	Black Fungus <i>Ceratocystis</i> Microbe	24	4.2	14	28.6	38	21.1			
		24	0.0	14	7.1					
		24	8.3	14	0.0					
100	Black Fungus Microbe <i>Penicillium</i>	18	5.6	28	28.6	18	16.7			
		18	5.6							
		18	5.6							
All Isolates and Distances Pooled		66	9.1	28	28.6	214	14.9			

old Douglas-fir seedling was observed (Table 10). Root samples from an untreated Douglas-fir seedling exhibited a mean cpm of  $40.4 \pm 3.0$ ,  $n = 5$ , while 33.3% of the treated root samples had  $\geq 400$  cpm, a minimum of nine fold higher than in the control seedling (Table 10). Similar results were obtained when the experiment was repeated in May of 1994. The level of radioactivity was similar when root samples were assayed by sample combustion and liquid scintillation spectrometry or by ethanol extraction and liquid scintillation spectrometry, 25.0 and 16.7%, respectively, of root samples had  $> 400$  cpm (Table 10).

**Table 10.** Frequency of four levels of radioactivity in root samples from one Douglas-fir seedling treated in March of 1992 and three seedlings treated in May of 1994, 76 h after treatment of their cut stems with a 4 uCi dose of  $^{14}\text{C}$ -glyphosate. Root samples in May of 1994 were assayed for radioactivity using two techniques: sample combustion and liquid scintillation spectrometry or extraction in 95% ethanol and liquid scintillation spectrometry.

Date and Protocol	No. of Samples	Frequency (%) by Radioactivity Level			
		0-199 cpm	200-399 cpm	400-999 cpm	> 1000 cpm
March/92 Extraction	27	44.4	22.2	29.6	3.7
May/94 Extraction	12	58.3	25.0	16.7	0
Combustion	12	66.7	8.3	25.0	0

## CHAPTER IV - DISCUSSION

The results from this study do not uphold the hypothesis that primary colonization of Douglas-fir stumps by saprophytic fungi would be promoted by treatment of cut stump surfaces with glyphosate. The frequency and composition of fungal colonizers was not different between control and treated stumps at 6, 10.5 and 14 months after treatment at two sites (Tables 1, 2 and 4). Douglas-fir stumps from 20-year-old trees were rapidly colonized by stain fungi and insects in the absence of any treatment.

Due to their rapid growth, stain fungi were effective colonizers of stump sapwood irregardless of whether insect vector attack was light or heavy. At the Malcolm Knapp Research Forest, where disturbance from activities such as logging was minimal, root feeding insect populations were low, but attack at the root collar was sufficient to yield almost complete colonization of the root system by stain fungi at 10.5 months after felling (Table 4). The importance of insect vectors in disseminating primary fungal colonizers of stump roots was evidenced by two control stumps near Mesachie Lake which were not successfully colonized by either insects or fungi 6 months after felling.

The distribution of stain fungi within freshly cut Douglas-fir stumps did not appear to be limited by stump defense responses or influenced by the intensity of primary inoculum ( a few inoculum points at the root collar resulted in almost complete colonization of the sapwood tissue after 10.5 months). In addition, the majority of stumps from 20-year old trees did not appear able to resist insect attack completely. Therefore, treatments which

inhibit stump defenses may increase the success of insect colonizers, or the density of stain fungi mycelium, but will not influence the extent of the distribution.

Treatment of stumps with glyphosate did not alter the colonizing insect species, but in one instance did increase the success of colonization by *H. nigrinus* and *S. carinatus* after 14 months (Table 3). This observation is similar to that found for lodgepole pines in which larval mines of the mountain pine beetle, *Dendroctonus pseudotsugae* Hopkins, were greater in number and longer, and larvae were larger in the phloem of glyphosate-treated trees than in control trees (Bergvinson 1989; Bergvinson and Borden 1992a). Glyphosate treated lodgepole pines inoculated with *Ophiostoma clavigerum* (Robinson-Jeffrey and R.W. Davidson) T.C. Harrington, a blue stain fungal associate of the mountain pine beetle, had lesions up to seven times larger than in control trees (Bergvinson and Borden 1992b). Bergvinson and Borden (1992a) concluded that enhanced brood development resulted from glyphosate-induced inhibition of the secondary defense response in the tree to invasion by the beetle larvae and its symbiotic fungi. This hypothesis could explain the higher degree of root phloem colonization by insects observed in treated stumps after 14 months at Mesachie Lake (Table 3). Although at either site stain fungi were equally abundant in treated and control stumps after 6, 10.5 and 12 months, decreased resistance in treated stumps may have allowed a greater density of *Ceratocystis* mycelium thus favouring beetle development. The lack of a difference in insect colonization frequency after 10.5 months at the Malcolm Knapp Research Forest (Table 5) was probably the result of low insect populations.

Although fungal colonization of conifer stump roots in this study corroborates previous findings on colonization of above ground wood, results from three studies on fungal colonization of conifer stumps are partially contradictory. Meredith (1959, 1960) found that 12 months after felling pine trees in Britain, stump tissues were colonized by wood decay Basidiomycetes (*Heterobasidion annosus* (Fr.) Bref., *Peiniophora gigantea* (Fr.) Masee, *S. sanguinolentum* Alb. et Schw.) and blue stain fungi. The author concluded that fungi infected the fresh cut stump surface with air-borne spores, and initial colonization of the roots proceeded from the body of the stump. In northern California, 90% of pine stumps cut 2.5 months earlier were colonized by *P. gigantea* (Hunt and Cobb 1982). *T. viride* colonized from 8 to 67% of stumps cut 2.5, 3, 5, 8, 10, and 12 months previous. Stain fungi were not found colonizing stumps cut 2.5, 3 or 5 months previously.

Fungi were not sampled from stump boles in this study. However, no decay of stump boles was observed after 6, 10.5 or 14 months and there was no evidence of root colonization via the bole. Greater than 14 months may be required for stump surface colonizing Basidiomycetes to become established. Wood decay fungi from the soil or stump surface could eventually displace stain fungi, which can die out when free nutrients are consumed.

The primary insect fauna colonizing Douglas-fir stumps and roots at two sites in B.C. were the same as those found to colonize pine stumps in California and Douglas-fir stumps in Oregon. In northern California, red turpentine beetles, *Dendroctonus valens* LeConte colonized the root collar of 91% of 35 pine stumps cut 2.5, 3 and 5 months previously.

An unidentified species of Cucujidae colonized root collars of pine stumps cut 5-16 months previously (Hunt and Cobb 1982). *Hylastes macer* was found to be an early colonizer of ponderosa pine stump roots in California (Goheen and Cobb 1978). Witcosky and Hansen (1985) found that *H. nigrinus*, *S. carinatus* and *Pissodes fasciatus* (LeConte) represented 97% of the insects colonizing the root systems of 10-15, 14 and 24 year-old Douglas-fir trees infected with black stain root disease.

*Leptographium wageneri*, the causal agent of black stain root disease, was isolated from 73% of the stumps on Vancouver Island and from all stumps at the Malcolm Knapp Research Forest. *L. wageneri* is a vascular wilt pathogen that is spread by root to root contact or by insect vectors (Hansen *et al.* 1988). It is usually found in Douglas-fir stands < 30 years old (Morrison and Hunt 1988). Two weevils, *P. fasciatus* and *S. carinatus*, and a root beetle, *H. nigrinus*, have been confirmed to be vectors in California and Oregon (Hansen *et al.* 1988; Harrington *et al.* 1985). These insects colonized the root phloem tissue of living Douglas-firs infected with *L. wageneri* (Witcosky and Hansen 1985). In the field, 1-5% of beetle vectors yielded *L. wageneri* when plated in culture. *H. nigrinus* is believed to be important in long-distance dispersal of the black stain root pathogen and *S. carinatus* important in local tree to tree spread within infection centres (Hansen *et al.* 1988).

Hansen *et al.* (1988) observed fresh stumps colonized by *L. wageneri*, and in Northern California, Harrington *et al.* (1983) found the disease associated with precommercial thinning. Thinning operations increased the activity of the beetle vectors (Harrington *et al.*



1985). Increased vector numbers and pathogen inoculum available in cut stumps could account for the association of thinning and increased disease (Hansen *et al.* 1988). In B.C., no correlation between the occurrence of black stain root disease and thinning operations has been made and potential insect vectors have not been verified (Morrison and Hunt 1988).

Survival of *L. wagneri* var. *ponderosum* in dead tissues of infected trees is reported to be as short as a few months (Cobb 1988). *L. wagneri* colonizing Douglas-fir stumps near Mesachie Lake survived 14 months, decreasing from an average of  $9.7 \pm 6.3\%$  after 6 months to  $3.1 \pm 3.7\%$  after 14 months.

Because black stain root disease is associated with site disturbance (Hansen *et al.* 1988), it was not surprising to find *L. wagneri* colonizing stumps on Vancouver Island, where nearby logging was intense, and brood material on which beetle vector populations could increase was in ample supply. High beetle populations near Mesachie Lake were reflected by the mass colonization of root phloem tissue 14 months after treatment. However, it was surprising to find *L. wagneri* colonizing stumps with a mean frequency of  $26.9 \pm 17.0\%$  at the Malcolm Knapp Research Forest where site disturbance is minimal and beetle populations were low. Weevil activity at the root collar was evident on all of the stumps. *L. wagneri* was found colonizing the root collar area of dead suppressed trees in the area. Dying suppressed trees may have contained the inoculum source, and *S. carinatus* may have vectored the fungus from the root collar of dead suppressed trees to the stumps. In nature, root collar weevils and a continuous supply of dying suppressed

trees may be important to maintain an inoculum pool in areas where disturbance is low. The high frequency of *L. wagneri* in stumps with little insect attack, compared to lower frequencies in stumps with high insect attack, may be due to reduced levels of competition from other *Ceratocystis* spp. The lack of black stain root disease at either site, in light of the high incidence of both pathogen and vector, indicates the possibility of a weakly pathogenic strain of *L. wagneri*. Such a strain could also explain the prolonged saprophytic survival in this study compared to that in published reports.

Data from this study revealed interesting implications concerning the survival of *P. weirii* inoculum in young second growth Douglas-fir trees, but is considered descriptive due to small sample sizes. Left undisturbed, infected trees developed from an early to an advanced symptom stage during which inoculum levels in root systems increased by an average of 45%. During this time, tree defenses probably prevented entry into the root system by soil saprophytes, as well as root feeding insects and associated stain fungi, thus providing a sterile environment in which *P. weirii* could develop. In both early and advanced symptomatic trees, *P. weirii* colonized the roots essentially in monoculture. A low frequency (8.4%) of fungi other than *P. weirii* was found colonizing decayed wood. The majority of these fungi was represented by an unidentified black fungus (5.1%) which appeared to be associated with *P. weirii* decay. At advanced symptom stages, where the majority of the root system has been infected by *P. weirii*, trees succumb to facultative parasites such as bark beetles, root collar weevils and *Armillaria* spp. By the time saprophytes gain entry to the infected tree, *P. weirii* has already occupied the majority of

the root system and has reached a point of maximum inoculum potential. Since the outer bark is non-living and resistant to microbial decomposition, bark structure can remain intact (due to the cementing action of resin in the phloem tissue) and important as a physical and chemical barrier to soil saprophytic fungi long after tree roots have died. Since this resource is no longer suitable for insects such as bark beetles and weevils, these agents do not breach the bark barrier. As decay of the sapwood continues, root and bark structure is compromised. This may be important in the natural succession of decay and invasion by secondary fungi (Figure 3). *P. weirii* survived only in roots from stumps 20, 30 and 50 years old when the bark remained intact (Hansen 1976, 1979). The location of fungi other than *P. weirii* colonizing decayed wood did not differ significantly with respect to distance from the root collar (Tables 7 and 9). In contrast *Trichoderma spp.* and other unidentified fungi were isolated from infected stumps aged 1 and 11 years more frequently from decayed root disks sampled farthest from the root collar (Goldfarb *et al.* 1989). As the distance from the root collar increases, root size decreases. Smaller roots decay more rapidly and therefore may be in a state of advanced decay where bark structure is breached.

Cutting infected trees appears to have induced insect attack of the root systems at symptom stages prior to complete decay. When infected trees were cut, roots not infected by *P. weirii* were colonized by bark beetles, weevils and associated stain fungi. As shown for ponderosa pine stumps infected with *H. annosus* (Hunt and Cobb 1982), insect species colonizing *P. weirii* infected stumps should not be different from those observed

**Figure 3.** Hypothetical succession of *Phellinus weirii* inoculum in infected 20 year old Douglas-fir trees. As trees progress from early to advanced symptom stages, *Phellinus weirii* colonizes the root system in the absence of saprophytic fungi. When trees decline to the point where they can no longer resist saprophytic colonization, *Phellinus weirii* has brought the majority of the root system to an advanced stage of decay, and the inoculum deteriorates naturally.

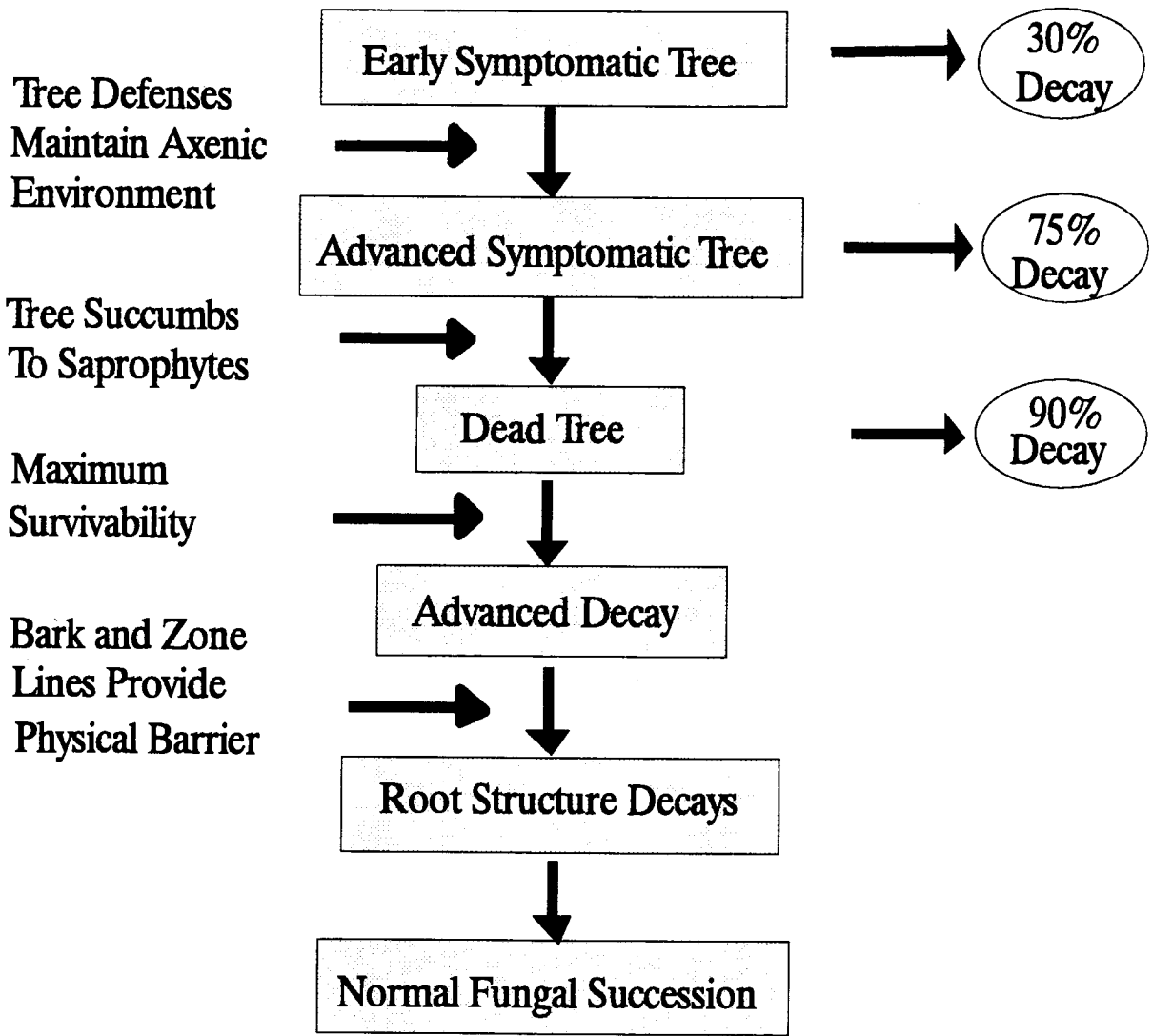

colonizing noninfected stumps. Patches of sound sapwood within incipient infected roots were colonized by stain fungi. The incidence of fungi and microbes colonizing wood with incipient decay by *P. weirii* was three times greater than that in advanced decayed wood. *Phellinus weirii* was apparently displaced from 10% of decayed samples from infected stumps but only from 0.5% of decayed samples from eight infected trees.

These results indicate that disturbing the natural succession of inoculum development, by killing early-infected trees, may reduce the volume of inoculum and its persistence. Roots colonized by stain fungi should not be a suitable substrate for *P. weirii*, thus reducing inoculum levels from a potential of about 90% to approximately 30%. Of the remaining 30%, at least half should be in an early stage of decay. Results here and elsewhere (Nelson 1964, 1967) suggest that wood with incipient decay is more susceptible to invasion by secondary fungi than wood with advanced decay, which could hasten the natural deterioration in viability. Finally, the remaining 15% of advanced decay would deteriorate naturally (Figure 4).

These hypotheses have implications toward inoculum isolation by bridge tree removal in second growth Douglas-fir as a strategy to manage laminated root rot. This strategy depends on relatively clear expression of disease centres by stand age 20-30 years. An economical means to kill living infected trees and bridge trees surrounding infection centres may not only isolate original inoculum from new hosts, but reduce inoculum potential in infected trees. The herbicide glyphosate, formulated as Ez-Ject injection capsules (Monsanto, Delta, B.C.), would provide an economical tool. Ez-ject injection

**Figure 4.** Hypothetical succession of *Phellinus weirii* inoculum in infected 20 year old Douglas-fir trees which have been cut at an early symptom stage. At early symptomatic stages, approximately 30% of the root system volume has been infected. Assuming that approximately two-thirds of decay at early symptom stages is incipient, of the 30% decay, 20% will be incipient and 10% advanced. Since incipient decay may be more susceptible than advanced decay to colonization by saprophytic fungi, which gain entry when the infected tree is cut, the natural decline of inoculum may be accelerated. The 10% advanced decay deteriorates naturally. Alternatively, if early symptomatic trees are not cut, inoculum levels, mainly composed of advanced decay, reach 75 - 90% of the root system volume.

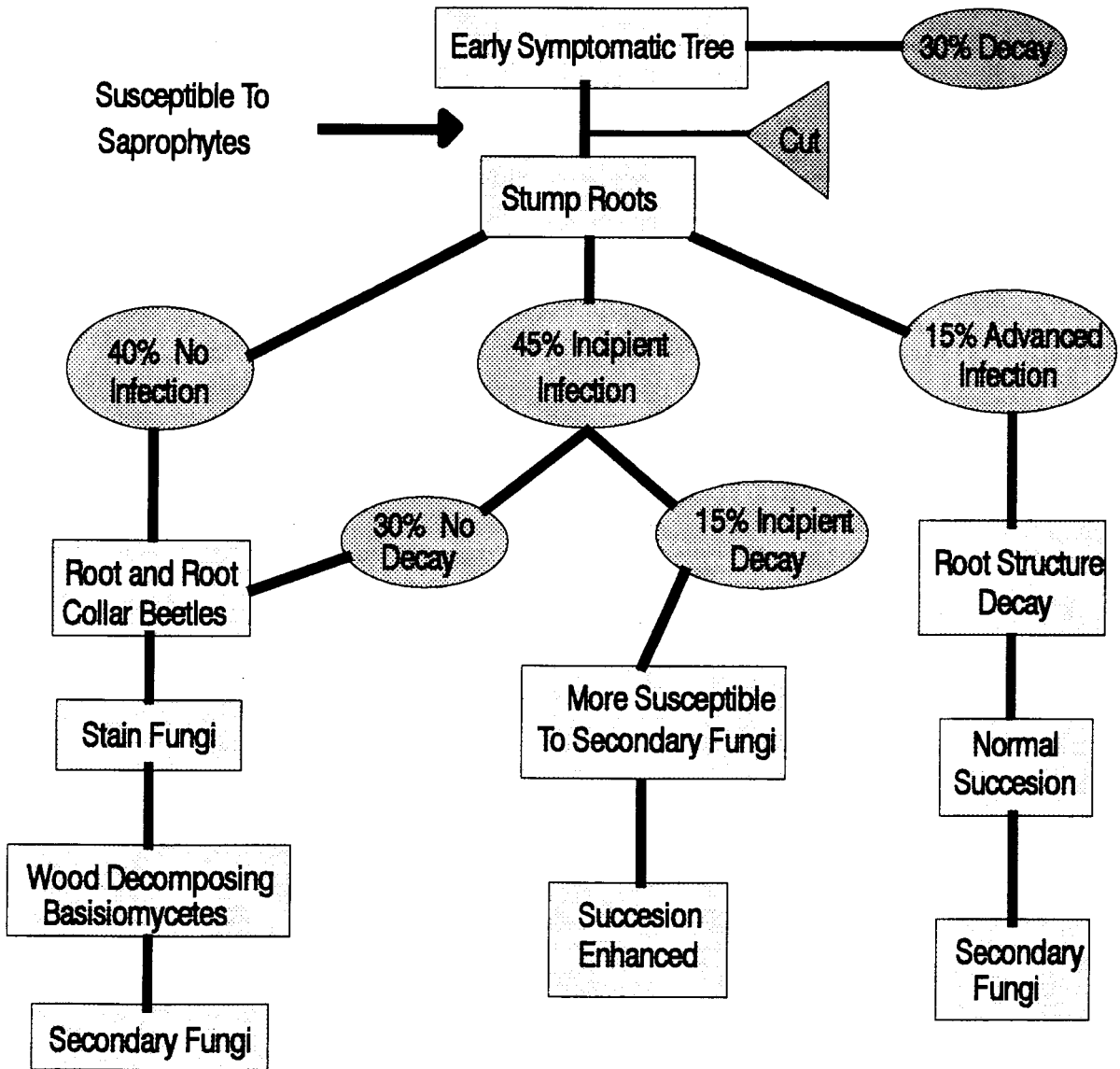



capsules are currently registered for use on conifers in Canada, and the label need only be amended to include management of laminated root rot. Bridge tree removal is especially suited for intensive management on high quality sites and could be used as a treatment approximately 20 years following destumping. After destumping, remaining inoculum in the soil tends to be small and discrete, created when infected roots break off from stumps during removal. Inoculum left after destumping should not have long term survival potential, but will survive in the stand unless isolated from new hosts. Failure to manage laminated root rot in juvenile monoculture second growth Douglas-fir stands will result in large inoculum volumes in the large root systems after harvest.

## LITERATURE CITED

- Banik, M.T., Paul, J.A., Burdsall, H.H. and Cook, M.E. 1993. Serological differentiation of two forms of *Phellinus weirii*. *Mycologia* 85:605-611.
- Beale, J.D. 1987. Guidelines for the detection and treatment of laminated root rot in the Vancouver Forest Region. Forest Service Internal Report PM-V-6.
- Bergvinson, D.J. 1989. Enhanced development of the mountain pine beetle, *Dendroctonus ponderosae* Hopkins, in lodgepole pine treated with glyphosate. MPM Thesis, Simon Fraser University, Burnaby, B.C.
- Bergvinson, D.J. and Borden, J.H. 1992a. Glyphosate-induced changes in the attack success of the mountain pine beetle and impact of its natural enemies. *Entomol. Exp. Appl.* 60:203-212.
- Bergvinson, D.J. and Borden, J.H. 1992b. Enhanced colonization by the blue stain fungus *Ophiostoma clavigerum* in glyphosate-treated sapwood of lodgepole pine. *Can. J. For. Res.* 22:206-209.
- Berryman, A.A. 1989. Adaptive pathways in the scolytid-fungus associations. Pp 145-156 In: *Insect-fungus interactions*. Wilding, N., Collins, N.W., Hammond, P.W. and Weber, J.F. eds. Academic Press, San Diego.
- Biggs, A.R., Merrill, W. and Davis, D.D. 1984. Discussion: response of bark tissues to injury and infection. *Can. J. For. Res.* 14:351-356.
- Bloomberg, W.J. and Reynolds, G. 1982. Factors affecting transfer and spread of *Phellinus weirii* mycelium in roots of second-growth Douglas-fir. *Can. J. For. Res.* 12:424-427.
- Brammall, R.A. and Higgins, V.J. 1988. The effect of glyphosate on resistance of tomato to *Fusarium* crown and root rot disease and on the formation of host structural defensive barriers. *Can. J. Bot.* 66:1547-1555.
- British Columbia M.O.F. 1989. Management guidelines for laminated root rot in the Vancouver Forest Region.
- Casely, J.C. and Coupland, D. 1985. Environmental and plant factors affecting glyphosate uptake, movement and activity. Pp 92-123 In: *The herbicide glyphosate*. Grossbard, E. and Atkinson, D. eds. Butterworths, London.

- Childs, T.W. 1963 *Poria weirii* root rot. *Phytopath.* 53:1124-1127.
- Cobb, F.W. Jr. 1988. *Leptographium wageneri*, cause of black-stain root disease: a review of its discovery, occurrence and biology with emphasis on pinyon and ponderosa pine. In: *Leptographium* root diseases on conifers. Harrington, T.C. and Cobb, F.W. Jr. eds. APS Press, St. Paul.
- Coggins, J.R. 1989. The shikimate pathway as a target for herbicides. Pp 97-112 In: *Herbicides and plant metabolism*. Dodge, A.D. ed. Cambridge University Press, New York.
- Cole, D.J. 1985. Mode of action of glyphosate - a literature analysis. Pp 48-74 In: *The herbicide glyphosate*. Grossbard, E. and Atkinson, D. eds. Butterworths, London.
- Condrashoff, S.F. 1968. Biology of *Steremnius carinatus* (Coleoptera: Curculionidae), a reforestation pest in coastal British Columbia. *Can. Entomol.* 100:386-394.
- D'Anieri, P., Zedaker, S.M., Seiler, J.R. and Kreh, R.E. 1990. Glyphosate translocation and efficacy relationships in red maple, sweetgum, and loblolly pine seedlings. *For. Sci.* 36:438-447.
- Dowding, P. 1984. The evolution of insect-fungus relationships in the primary invasion of forest timber. Pp 133-154 In: *Invertebrate-microbial interactions*. Anderson, S.M., Rayner, A.D.M. and Walton, D.W.H. eds. Cambridge University Press, Cambridge.
- Fink, K.E., Humphreys, P. and Hawkins, G.V. 1989. Field guide to pests of managed forests in British Columbia. Forest Pest Review Committee of B.C. and B.C. M.O.F. Publication #16, ISSN 0843-4719.
- Fraser, R.G. 1989. Management of laminated root rot caused by *Phellinus weirii* (Murr.) Gilbertson in Douglas-fir. MPM Thesis, Simon Fraser University, Burnaby, B.C.
- Garrett, S.D. 1970. *Pathogenic root-infecting fungi*. Cambridge University Press, 1970, Cambridge.
- Gilbertson R.L. 1974. *Fungi that decay ponderosa pine*. University of Arizona Press, Tucson.
- Goheen, D.J. and Cobb, F.W. Jr. 1978. Occurrence of *Verticicladiella wageneri* and its perfect state, *Ceratocystis wageneri* sp. nov., in insect galleries. *Phytopath.* 69:1192-1195.

- Goldfarb, B., Nelson, E.E., and Hansen, E.M. 1989a. *Trichoderma* species from Douglas-fir stumps and roots infested with *Phellinus weirii* in the Western Cascade Mountains of Oregon. *Mycologia* 81:134-138.
- Goldfarb, B., Nelson, E.E. and Hansen, E.M. 1989b. *Trichoderma* spp.: growth rates, and antagonism to *Phellinus weirii* in vitro. *Mycologia* 81:375-381.
- Green, T.H., Minoque, P.J., Brewer, C.H., Glover, G.R. and Gjerstad, D.H. 1992. Absorption and translocation of [<sup>14</sup>C]glyphosate in four woody plant species. *Can. J. For. Res.* 22:785-789.
- Hansen, E.M. 1976. Twenty-year survival of *Phellinus (Poria) weirii* in Douglas-fir stumps. *Can. J. For. Res.* 6:123-128.
- Hansen, E.M. 1979. Survival of *Phellinus weirii* in Douglas-fir stumps after logging. *Can. J. For. Res.* 9:484-488.
- Hansen, E.M. 1986. Inoculation of Douglas-fir roots with isolates of *Phellinus weirii* on sites differing in root rot severity. *Can. J. For. Res.* 16:619-623.
- Hansen, E.M., Goheen, D.J., Hessburg, P.F., Witcosky, J.J. and Schowalter, T.D. 1988. Biology and management of black-stain root disease in Douglas-fir. In: *Leptographium* root diseases on conifers. Harrington, T.C. and Cobb, F.W. Jr. eds. APS Press, St. Paul.
- Harmon, M.E., Franklin, J.F., Swanson, F.J., Sollins, P., Gregory, S.V., Lattin, J.D., Anderson, N.H., Cline, S.P., Aumen, N.G., Sedell, J.R., Lienkaemper, G.W., Cromack, Jr., and Cummins, K.W. 1986. Ecology of coarse woody debris in temperate ecosystems. *Adv. Ecolog. Res.* 15:133-276.
- Harrington, T.C. 1981. Cycloheximide sensitivity as a taxonomic character in *Ceratocystis*. *Mycologia* 73:1123-1129.
- Harrington, T.C. and Cobb, F.W. Jr. 1988. Preface. In: *Leptographium* root diseases on conifers. Harrington, T.C. and Cobb, Jr., F.W., eds. APS Press, St. Paul.
- Harrington, T.C., Cobb, F.W. Jr. and Lownsbery, J.W. 1985. Activity of *Hylastes nigrinus*, a vector of *Verticicladiella wageneri*, in thinned stands of Douglas-fir. *Can. J. For. Res.* 15:519-523.
- Harrington, T.C., Reinhart, C., Thornburgh, D.A. and Cobb, F.W. Jr. 1983 Association of black-stain root disease with precommercial thinning of Douglas-fir. *For. Sci.* 29:12-14.

- Hunt, R.S. and Cobb F.W. Jr. 1971. Selective medium for the isolation of wood-rotting basidiomycetes. *Can. J. Bot.* 49:2064-2065.
- Hunt, R.S. and Cobb F.W. Jr. 1982. Potential arthropod vectors and competing fungi of *Fomes annosus* in pine stumps. *Can. J. Plant Pathol.* 4:247-253.
- Hutchinson, A.S., Fay, H. and Knutson, D. 1985. A selective medium for *Phellinus weirii*. *Can. J. of For. Res.* 15:746-748.
- Johansson, T. 1985. Herbicide injections into stumps of aspen and birch to prevent regrowth. *Weed Res.* 25:39-45.
- Kendrick, W.B. 1962. *The Leptographium complex*. *Can. J. Bot.* 40:771-797.
- Levesque, C.A. and Rahe, J.E. 1992. Herbicide interactions with fungal root pathogens, with special reference to glyphosate. *Ann. Rev. of Phytopathol.* 30:579-602.
- Liese, W. 1970. Ultrastructural aspects of woody tissue disintegration. *Ann. Rev. Phytopathol.* 8:231-258.
- Meredith, D.S. 1959. The infection of pine stumps by *Fomes annosus* and other fungi. *Ann. Bot.* 23:455-476.
- Meredith, D.S. 1960. Further observations on fungi inhabiting pine stumps. *Ann. Bot.* 24:63-78.
- Morrison, D.J. and Hunt, R.S. 1988. *Leptographium* species associated with root disease of conifers in British Columbia. Pp 81-95 In: *Leptographium root diseases on conifers*. Harrington, T.C. and Cobb, Jr., F.W. eds. APS Press, St. Paul.
- Morrison, D.J., Merler, H. and Norris, D. 1991. Detection, recognition and management of *Armillaria* and *Phellinus* root diseases in the southern interior of British Columbia. Forest Resource Development Agreement Report #179.
- Mounce, I., Bier, J.E. and Nobles, M.K. 1940. A root rot of Douglas-fir caused by *Poria weirii*. *Can. J. For. Res.* 18:522-533.
- Nelson, E.E. 1964. Some probable relationships of soil fungi and zone lines to survival of *Poria weirii* in buried wood blocks. *Phytopath.* 54:120-121.

- Nelson, E.E. 1967. Factors affecting survival of *Poria weirii* in small buried cubes of Douglas-fir heartwood. For. Sci. 13:78-84.
- Nelson, E.E. 1969. Occurrence of fungi antagonistic to *Poria weirii* in a Douglas-fir forest soil in Western Oregon. For. Sci. 15:49-54.
- Nelson, E.E. 1975. Survival of *Poria weirii* on paired plots in alder and conifer stands. Microbios 12:155-158.
- Nelson, E.E. 1976. Effect of urea on *Poria weirii* and soil microbes in an artificial system. Soil. Biol. Biochem. 8:51-53.
- Nelson, E.E., Goldfarb, B. and Thies, W.G. 1987. *Trichoderma* species from fumigated Douglas-fir roots decayed by *Phellinus weirii*. Mycologia 79:370-374
- Nelson, E.E. and Hartman, T. 1975. Estimating spread of *Poria weirii* in a high elevation mixed conifer stand. J. of For. 73:141-142.
- Nelson, E.E. and Thies, W.G. 1985. Colonization of *Phellinus weirii*-infested stumps by *Trichoderma viride*: effect of isolate and inoculum base. Eur. J. For. Path. 15:425-431.
- Nelson, E.E. and Thies, W.G. 1986 Colonization of *Phellinus weirii*-infested stumps by *Trichoderma viride*: effects of season of inoculation and stage of wood decay. Eur. J. For. Path. 16:56-60.
- Rahe, J.E., Levesque, C.A. and Johal, G.S. 1990. Synergistic role of soil fungi in the herbicidal efficacy of glyphosate. Pp 260-275 In: Microbes and microbial products as herbicides. Hoagland, R.E. ed. American Chemical Society Symposium Series 439, 197<sup>th</sup> National Meeting of the American Chemical Society, Dallas, Texas, April, 1989.
- Rayner, A.D.M. 1979 Internal spread of fungi inoculated into hardwood stumps. New Phytol. 82:505-517.
- Rishbeth, J. 1972. Resistance to fungal pathogens of tree roots. Proc. Roy. Soc. Lond. 181:333-351.
- Shain, L. 1979. Dynamic responses of differentiated sapwood to injury and infection. Phytopath. 69:1143-1147.
- Shortle, W.C. 1979. Mechanisms of compartmentalization of decay in living trees. Phytopath. 69:1147-1151.

- Stasiak, M.A., Hofstra, G. and Fletcher, R.A. 1992. Physiological changes induced in birch seedlings by sublethal applications of glyphosate. *Can. J. For. Res.* 22:812-817.
- Swift, M.J. and Boddy, L. 1984. Animal-microbial interactions in wood decomposition. Pp 89-132 In: *Invertebrate-microbial interactions*. Anderson, J.M., Rayner, A.D.M. and Walton, D.W.H. eds. Cambridge University Press, Cambridge.
- Thies, W.G. 1984. Laminated root rot: the quest for control. *J. of For.* 82:345-356.
- Thies, W.G. and Nelson, E.E. 1982. Control of *Phellinus weirii* in Douglas-fir stumps by the fumigants chloropicrin, allyl alcohol, vapam, or vorlex. *Can. J. For. Res.* 12:528-532.
- Thies, W.G. and Nelson, E.E. 1987. Reduction of *Phellinus weirii* in Douglas-fir stumps by the fumigants chloropicrin, vorlex or methylisothiocyanate. *For. Sci.* 33:316-331.
- Upadhyay, H.P. 1981. A monograph of *Ceratocystis* and *Ceratocystiopsis*. The University of Georgia Press, Athens
- USDA Forest Service 1985. Laminated root rot: a guide for reducing and preventing losses in Oregon and Washington forests. USDA Forest Service, P.O. Box 3623 Portland, Oregon.
- Wallis, G.W. 1976. Growth characteristics of *Phellinus (Poria) weirii* inoculum in soil and on root and other surfaces. *Can. J. For. Res.* 6:229-232.
- Wallis, G.W. and Reynolds, G. 1962. Inoculation of Douglas-fir roots with *Poria weirii*. *Can. J. Bot.* 40:637-645.
- Wallis, G.W. and Reynolds, G. 1965. The initiation and spread of *Poria weirii* root rot of Douglas-fir. *Can. J. Bot.* 43:1-9
- Wingfield, M.J. 1985. Reclassification of *Verticicladiella* based on conidial development. *Trans. Br. Mycol. Soc.* 85:81-93
- Witcosky, J.J. and Hansen E.M. 1985. Root-colonizing insects recovered from Douglas-fir in various stages of decline due to black-stain root disease. *Phytopath.* 75:399-402
- Zar, J.H. 1984. *Biostatistical analysis*. Prentice-Hall, Inc., Englewood Cliffs, N.J.
- Zethner-Moller, O. and Rudinsky, J.A. 1967. On the biology of *Hylastes nigrinus* (Coleoptera:Scolytidae) in Western Oregon. *Can. Entomol.* 99:897-916