

LUMINESCENCE DATING OF QUARTZITE FROM THE DIRING YURIAKH SITE

by

Michael Richards

B.A., Simon Fraser University, 1992

THESIS SUBMITTED IN PARTIAL FULFILLMENT OF

THE REQUIREMENTS FOR THE DEGREE OF

MASTER OF ARTS

in the Department

of

Archaeology

© Michael Phillip Richards, 1994

SIMON FRASER UNIVERSITY

August 1994

All rights reserved. This work may not be reproduced in whole or in part, by photocopy or other means, without permission of the author.

APPROVAL

NAME Michael Phillip Richards
DEGREE MA
TITLE Luminescence Dating of Quartzite from the Diring Yuriakh Site

EXAMINING COMMITTEE:

Chair Dr. Jon Driver

Dr. D. J. Huntley, Professor, ~~Physics~~

Dr. D. E. Nelson
Professor
Archaeology

Dr. Ralph Korteling
Associate Chair
Chemistry

Date Approved: August 9, 1994

PARTIAL COPYRIGHT LICENSE

I hereby grant to Simon Fraser University the right to lend my thesis or dissertation (the title of which is shown below) to users of the Simon Fraser University Library, and to make partial or single copies only for such users or in response to a request from the library of any other university, or other educational institution, on its own behalf or for one of its users. I further agree that permission for multiple copying of this thesis for scholarly purposes may be granted by me or the Dean of Graduate Studies. It is understood that copying or publication of this thesis for financial gain shall not be allowed without my written permission.

Title of Thesis/Dissertation:

Luminescence Dating of Quartzite from the Diring Yuriakh Site

Author:

Signature

Michael Phillip Richards

Name

August 9, 1994

Date

Abstract

The lower cultural stratum (stratum 5) at the Diring Yuriakh archaeological site, in Siberia, Russia, contains crude stone tools, which, it has been suggested, were made before the currently accepted earliest occupation of Siberia in the Upper Palaeolithic (ca. 35,000 years ago). The stratum 5 artifacts are mostly quartzites, which contain a great deal of quartz. The artifacts lie on a deflation surface, and show evidence of wind abrasion, so it is likely that they were exposed to sunlight for a period of time before being buried by the overlying sediments. Experiments were undertaken to see if these quartzites could be dated using luminescence dating techniques similar to those that have been used to date the last time quartz grains extracted from sediments were exposed to sunlight. A method was developed to extract quartz grains from the quartzites, layer by layer, using successive 30 minute treatments of 50 % hydrofluoric (HF) acid. By comparing the luminescence signal of quartz grains from each layer of quartzite recently exposed to sunlight, it was found possible to determine how deep into the quartzite the sunlight penetrated sufficiently to reduce the luminescence to zero. This allows selection of quartz grains for luminescence dating that should have been exposed to sufficient sunlight in the past. Dating attempts were made on quartzite samples from stratum 5 and stratum 2 (a deeper non-cultural stratum), and it was found that the traps in the quartz grains were in saturation. After determining the radiation dose required to saturate the traps the dose-rate was calculated for each sample and then minimum age limits were determined. A stratum 2 quartzite was found, using thermoluminescence, to be last exposed to sunlight more than 150 ka ago. A stratum 2 control

sample, which was expected to be in saturation on the basis of its supposed age, was found not to be in saturation, and yielded an equivalent dose of 440 ± 90 Gy, using 1.4 eV excitation. The evidence presented for a stratum 5 quartzite suggests it was last exposed to sunlight over 74 ka ago.

Acknowledgements

I would very much like to thank D.J. Huntley for his help and patient supervision. I would also like to thank D.E. Nelson for his helpful advice at key points during my research, and R. Korteling for his useful comments.

I would also like to thank George Morariu and Jinsheng Hu for their helpful advice, and M.A. Short and J. Ollerhead for the use of their figures. Thanks also to J.R. Prescott and R. Scholefield for the DY-31 TL emission spectra.

D.J. Huntley and I would like to thank Y.A. Mochanov for access to the Diring Yuriakh materials, and P.S. Solovjev for his help with sample collection at the site.

I would especially like to thank Darlene Weston for her support, and for putting up with me.

Table of Contents

	<u>Page</u>
Title Page.....	i
Approval Page.....	ii
Abstract.....	iii
Acknowledgements.....	v
Table of Contents.....	vi
List of Tables.....	viii
List of Figures.....	ix
1 Introduction.....	1
1.1 The Diring Yuriakh Site.....	1
1.2 The Question of the First Occupation of Siberia.....	3
1.3 Thesis Research.....	4
2 An Introduction to Luminescence Dating.....	6
2.1 Luminescence Dating of Ceramics.....	6
2.1.1 The Equivalent Dose.....	7
2.1.2 The Dose-Rate.....	9
2.2 Thermoluminescence Dating of Unheated Sediments.....	10
2.2.1 The Additive Dose Method.....	11
2.2.2 The R-Gamma Partial Bleach Technique.....	11
2.2.3 The Regeneration Method.....	13
2.3 Optical Dating.....	15
2.3.1 Argon Laser (2.4 eV) Excitation.....	16
2.3.2 IR Diode (1.4 eV) Excitation.....	17
2.3.3 Single Aliquot Equivalent Dose Determination.....	17
2.4 Preheats in Optical Dating.....	18
2.5 Anomalous Fading.....	19
2.6 Age Limits of Luminescence Dating.....	20
3 The Diring Yuriakh Site.....	21
3.1 Site Stratigraphy.....	21
3.1.1 Interpretation of the Site Stratigraphy.....	26
3.2 The Dating of the Diring Yuriakh Strata.....	27
3.2.1 Palaeomagnetic Data.....	28
3.2.2 Radiothermoluminescent Dates.....	29
3.2.3 Palaeoclimatic Data.....	30
4 The Classification and Mineralogy of the Quartzite and Sample Preparation.....	32
4.1 The Classification of Quartzite.....	32
4.2 The Classification of the Diring Yuriakh Quartzite.....	33
4.3 X-Ray Diffraction Experiments.....	34
4.4 Sample Preparation: Extraction of Quartz Grains using Hydrofluoric (HF) Acid.....	36
4.5 Disk Preparation.....	38

5	Luminescence Experiments.....	39
	5.1 Luminescence Characterization.....	39
	5.1.1 TL Responses.....	39
	5.1.2 Responses to 2.4 eV (Ar Laser) Excitation.....	40
	5.1.3 Responses to 1.4 eV (IR Diode) Excitation.....	45
	5.2 Effect of Sun Bleaching.....	45
6	Light Transmission and Sunlight Penetration Experiments....	49
	6.1 Light Transmission Experiments.....	49
	6.2 Sunlight Exposure of Quartz Grains Within the Quartzite..	51
	6.2.1 DY-44 Sunlight Penetration.....	54
	6.2.2 DY-32 Sunlight Penetration.....	56
7	Equivalent Dose Determinations.....	58
	7.1 TL Equivalent Dose From DY-31 (Stratum 2).....	58
	7.2 DY-31 Ar Laser Experiments.....	60
	7.3 1.4 eV (IR Diode) Excitation of DY-32 (Stratum 2).....	60
	7.4 1.4 eV (IR Diode) Excitation of DY-8 (Stratum 5).....	67
	7.6 Discussion.....	72
8	Dose-Rates and Ages.....	73
	8.1 Dose-Rate Equations.....	73
	8.2 Dose-Rate Calculations.....	74
	8.3 The Ages.....	76
9	Conclusions.....	78
	9.1 Conclusions.....	78
	9.2 Archaeological Conclusions.....	79
	9.3 Recommendations for Future Work.....	79
	Appendix A: Equipment.....	81
	Appendix B: Sample List.....	88
	Appendix C: Emission Spectra.....	89
	References.....	93

List of Tables

Table 8.1 Values for Dosimetry.....75
Table 8.2 Lower Limit Age Calculations.....75

List of Figures

	<u>Page</u>
Figure 2.1 The TL Glow Curve.....	8
Figure 2.2 The Additive Dose Method for TL Dating.....	8
Figure 2.3 The Effect of Sunlight Exposure on Optical and TL Signals of Quartz and Feldspar.....	12
Figure 2.4 The Additive Dose Method for TL Sediment Dating.....	12
Figure 2.5 The Partial Bleach Method.....	14
Figure 2.6 The Regeneration Method.....	14
Figure 3.1 Plan View of the Diring Yuriakh Excavations.....	22
Figure 3.2 The Diring Yuriakh Stratigraphy (profile).....	23
Figure 3.3 The Diring Yuriakh Summary Stratigraphy.....	24
Figure 4.1a-c XRD Spectra of Various Quartzites.....	35
Figure 5.1a-d TL Glow-Curves for DY-1b, DY-1c and DY-31.....	41
Figure 5.2a-d 2.4 eV Excitation Shine-Down Curves for DY-1b, DY-1c, DY-31 and DY-32.....	43
Figure 5.3a-c 1.4 eV Excitation Shine-Down Curves for DY-1c, DY-8 and DY-32.....	46
Figure 5.4 The Effect of Sunlight Exposure on Optical and TL Signals of DY-1c Quartz.....	47
Figure 6.1a,b Log of Light Transmission vs Sample Thickness.....	50
Figure 6.2a DY-1c TL Glow Curves and Photon Counts vs. HF Layer.....	52
Figure 6.3 DY-1c 2.4 eV Excitation Shine-Down Curves.....	53
Figure 6.4a,b DY-1d 2.4 eV Shine-Down Curves and Photon Counts vs. HF Layer Number.....	55
Figure 6.5 DY-44 Photon Counts vs. HF Layer Number.....	57
Figure 6.6 DY-32 Outer, Photon Counts vs. HF Layer Number.....	57
Figure 7.1a,b DY-31 TL Regeneration Experiment.....	59
Figure 7.2 DY-32 Preheat Experiment.....	62
Figure 7.3 Preheat Plateau Test for DY-32.....	63
Figure 7.4 DY-32 Outer 1.4 eV Excitation Regeneration Experiment....	64
Figure 7.5 DY-32 Photon Counts vs. Inner HF Layer Number.....	65
Figure 7.6 DY-32 Inner 1.4 eV Excitation Regeneration Experiment....	66
Figure 7.7 DY-8 Photon Counts vs. HF Layer Number.....	68
Figure 7.8a-e DY-8 1.4 eV Excitation Single Aliquot Experiment.....	70
Figure A.1 The TL Measurement Apparatus.....	82
Figure A.2 The 2.4 eV Excitation (Ar Laser) Measurement Apparatus...83	83
Figure A.3 The 1.4 eV Excitation (IR Diode) Measurement Apparatus...85	85
Figure C.1 DY-31 TL Emission Spectra.....	90
Figure C.2 Emission Spectrum of DY-1c under 1.4 eV Excitation.....	92

1 Introduction

1.1 The Diring Yuriakh Site

The Diring Yuriakh site is located in Siberia, Russia, on the east bank of the Lena river, about 140 km up river from Yakutsk at 61°12' N, and 128°28' E (Mochanov 1988:22). The site was first discovered in July 1982 by four Russian geologists who found human remains that were later dated to the Late Neolithic (3000-4000 years B.P.). The Prilensk Archaeological Project, a division of the Siberian Department of the Academy of Sciences, started excavating the site in 1982.

Test pits revealed more Late Neolithic burials, and near the burials the excavators found lithic artifacts identified as indicative of the late Paleolithic Diuktai culture (Mochanov 1988:23).

In a lower level Mochanov found a concentration of quartzite artifacts; these were separated from the Diuktai artifacts by 5-12 cm of sterile sand. These artifacts were unlike anything Mochanov had seen before in Siberia. There were "an anvil cobble, two cobble hammerstones, 8 'amorphous' flakes and 92 pieces of debitage." (Mochanov 1988:23). The flakes and cores were unprepared, or "nonsystematic" as Mochanov calls them, and had evidence of wind abrasion on them. The site was more fully excavated starting in 1983 in a very large excavation using bulldozers, and in subsequent field seasons over 4000 lithic artifacts were found in this lowest cultural layer (Mochanov 1992:3). According to Mochanov these tools are unlike any other assemblage in the world, except the artifacts from Lower Paleolithic Oldowan (ca. 1.8 million years ago (Leakey et al 1961)) sites in Africa.

There has been some question as to whether or not these quartzite pebbles are actually artifacts. The published lithic drawings (Mochanov 1988) certainly look like simple stone tools, and most researchers who have seen the lithic materials are confident that they are artifacts. Ackerman and Carlson (1991) visited this site in 1990 and examined the tools themselves:

"they [the artifacts] occur most frequently in concentrations around a large cobble anvil. Isolated artifacts are uncommon. Impact scars from unsuccessful attempts at fracturing are present on some specimens and many flakes can be refitted to core remnants. Most specimens are classifiable as cores and unmodified flakes and a lesser number as unifacial pebble choppers, core scrapers and scraper-planes. More advanced tool types are absent." (Ackerman and Carlson 1991:2)

On the basis of geological evidence, thermoluminescence dates and palaeomagnetic data Mochanov has suggested that the deposits which contain the lithics are between 3.4 and 1.8 million years old (Mochanov 1988, 1992). The oldest stone tools known are the aforementioned Oldowan tools from East Africa. The oldest stone tools found outside Africa are associated with Homo erectus, who emerged from Africa about 1 million years ago (Klein 1989). The first evidence of human occupation of northern Asia is at the site of Zhoukoudian (near Beijing) dated to about 500,000 years old (Aigner 1986). If Mochanov's dates for Diring Yuriakh are correct these stone tools would be the oldest found outside of Africa, and possibly the oldest tools in the world. However, Mochanov's dates are very contentious. The methods used to produce them have not been published, and the results cannot be accepted without this information. Ackerman and Carlson (1991) write that the geologists who visited the site would not accept any date earlier than 500,000 years, and many believed the cultural layer was actually considerably younger.

1.2 The Question of the First Occupation of Siberia

Most archaeological evidence indicates that Siberia was first occupied at a relatively late time, around 30 or 40,000 years ago, by people of the Upper Paleolithic Diuktai culture. However, there has been some discussion of the possibility of some Lower Palaeolithic sites in Siberia, yet the antiquity and authenticity of these few sites has been questioned.

Yi and Clark's 1983 review of the Lower Palaeolithic of Northeast Asia reports that there are 3 sites and a few surface finds in the Amur and Lena River basins in southern Siberia which reportedly have artifacts that "are made of pebbles and consist of the most part of choppers, chopping tools and 'beaked scrapers'" (Yi and Clark 1983:182). The "artifacts" from these few sites may not actually be artifacts, as although they "...are found in riverlaid conglomerates dated to the Middle Pleistocene, they are so primitive in appearance that there is some question whether they are man-made."

There is also the site of Ulalinka, first discovered in 1961. Okladnikov and Pospelova (1983:710) report that at this site...

"The main cultural level...differs from the upper one [an Upper Palaeolithic level] and from all other known Palaeolithic sites in Siberia principally in the strikingly archaic shapes of the tools and their primitive technology. The tools were made almost entirely from pebbles of yellowish-white quartzite, whole or split in half, and sometimes from pebbles of obsidian and quartzite fragments. The finds include choppers, chopping tools, scrapers...The stone inventory and the techniques of manufacture are so primitive and peculiar that they cannot be classified in the framework of the usual Lower Palaeolithic typology."

On the basis of palaeomagnetic data they suggested that the main cultural layer is older than 690,000 years, and actually dates from the Late Pliocene.

They state that the question of when Siberia was first occupied is one of the most important problems in Siberian archaeology, and that "the idea of a late occupation has been generally accepted because most of the archaeological remains [in Siberia] are no older than 25,000 years..."

There are many similarities between Ulalinka and Diring Yuriakh. Clearly the dating of the lowest cultural layer of Diring Yuriakh is of great importance to Siberian and world archaeology.

1.3 Thesis Research

Y.A Mochanov visited Simon Fraser University in 1992 to present a paper on the Diring Yuriakh site at the 45th Annual Northwest Anthropology Conference (Mochanov 1992). During this talk D.J. Huntley, of the Department of Physics, Simon Fraser University, (personal communication) realized that if the artifacts found (mostly quartzites) were indeed part of a deflation layer, there was a good chance they were exposed to sunlight at about the time of deposition in which case it might be possible to apply to them the same luminescence dating techniques used to date the last time buried sediments were exposed to sunlight. Dating unheated stones had not been attempted before, but if it were possible, luminescence dating could provide minimum ages for these tools, dating their burial by the overlying sediments.

In August, 1992, at the invitation of Y.A. Mochanov, D.J. Huntley of the Department of Physics, Simon Fraser University, visited the Diring Yuriakh site and collected quartzite and sediment samples for luminescence dating experiments. A partial sample list is given in *Appendix B*. Most of the samples were collected at night, and were immediately sealed in light-tight containers for transport back to Canada.

Many quartzites were collected from stratum 2 because they were available in abundance; and were considered to be very old. These were used in experiments to study and characterize the luminescence properties of the quartzites and to develop appropriate dating methods. Quartzites from the lowest cultural level, stratum 5, were collected for dating using methods

so developed. A number of stratum 5 quartzites that had been uncovered by excavations the previous year and had lain on the surface since then were also collected; these had been exposed to sunlight for 1 year, and were control samples in the sense that any valid dating technique should give an age of zero for them. No artifacts were used in these experiments.

The goal of this thesis was to develop a luminescence dating method that can date the last time stones, and therefore stone tools, were exposed to light. It was anticipated that problems would be encountered, and many were. No conclusions about the age of the Palaeolithic assemblages were made, but it is shown that there is a potential for optical dating suitably collected samples.

2 An Introduction to Luminescence Dating

This chapter provides a brief introduction to the basic concepts and methods of luminescence dating. First, thermoluminescence dating of pottery is used to illustrate the basic principles of all luminescence dating methods. Thermoluminescence and optical dating of unheated sediments are then described.

2.1 Thermoluminescence Dating of Ceramics

In many minerals, particularly quartz and feldspar, free electrons (which have been excited by radiation) can be "trapped" at impurities or other defects in their crystal structure. If grains of these minerals are then heated, these electrons are released from their traps and light, called thermoluminescence, is then emitted. The intensity of this light is related to the amount of radiation to which the grains were exposed. If the grains are immediately re-heated no light would be given off, because all of the trapped electrons will have been released by the first heating.

For example, as a potsherd is fired during manufacture, all trapped electrons are released. If the potsherd is then buried it is exposed to radiation from uranium (U), thorium (Th) and potassium (K) both in the surrounding soil and within the potsherd itself. This radiation causes electrons in the mineral grains to be excited, and some will then be trapped. If the grains in an excavated potsherd are then separated and the thermoluminescence measured, the intensity will depend on how long the potsherd has been exposed to radiation since the firing. This intensity can be used to determine the radiation dose the grains have received. If the

radiation dose-rate is determined (and assumed to be constant) the time elapsed since the sherd was last heated (fired) can be calculated from

$$\text{Age} = \frac{\text{Dose}}{\text{Dose-Rate}}$$

If the *Dose* is measured in grays, and the *Dose-Rate* in grays/year, the *Age* is given in years.

2.1.1 The Equivalent Dose

The equivalent dose is defined as the laboratory dose (measured in grays) given to a sample that produces the same luminescence as the dose the sample has received since its electron traps were last emptied. For pottery dating, heating of the pottery during firing empties these traps and "zeroes" the sample. The simplest way to measure this equivalent dose might be to heat up the sample and measure the light output, and then give the sample a laboratory radiation dose that leads to the same TL intensity. Unfortunately, heating a sample usually changes its sensitivity, thus the laboratory dose needed to produce the same amount of light as the original measurement may differ each time the sample is irradiated, heated, and measured. Hence a more sophisticated method is needed.

In TL dating of pottery, the equivalent dose is usually determined using the additive dose method. Several nominally identical aliquots of the sample are prepared. Some of these are left as they are (the natural, or "N" portion), and the others are given various laboratory gamma radiation doses (The N+gamma set). Each of these aliquots is then heated and the light given off is measured, resulting in a "glow curve" (see *Figure 2.1*). The TL intensity at a certain temperature is then plotted against the added laboratory dose, and extrapolation to zero intensity is then used to find the

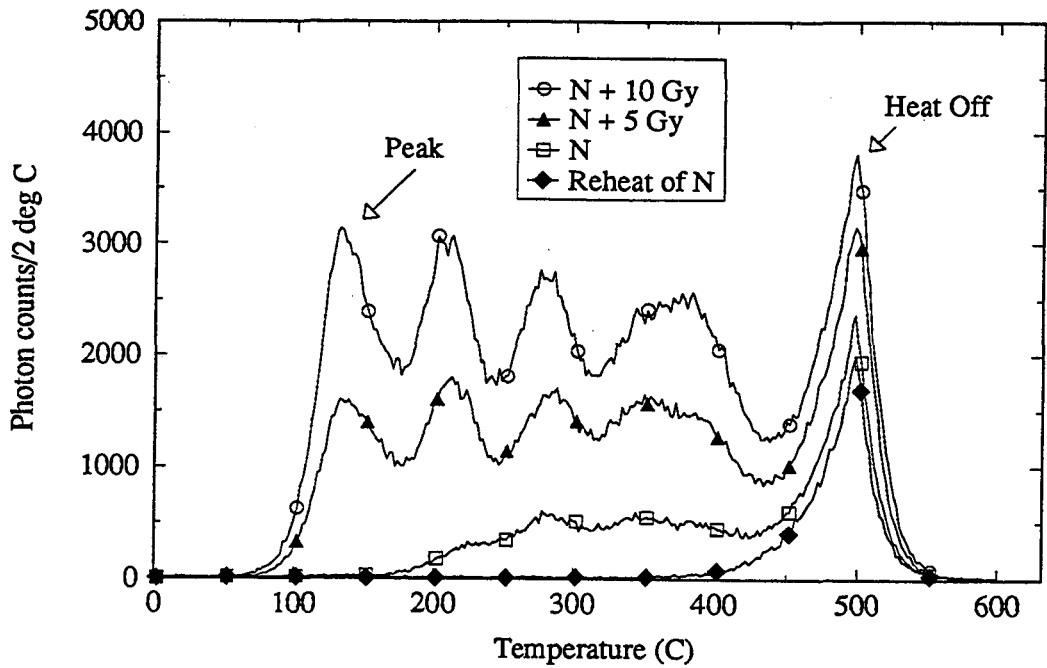

Figure 2.1: A TL glow curve from a heated sandstone (56-A) from Wyoming, U.S.A. Photon counts are plotted against the sample temperature. The untreated "natural" sample is labelled N. The samples given gamma radiation doses of 10 and 5 Gy are labelled N + 10 Gy and N + 5 Gy respectively. Note the well defined TL peaks in this sample and how the peak intensity increases with added doses.

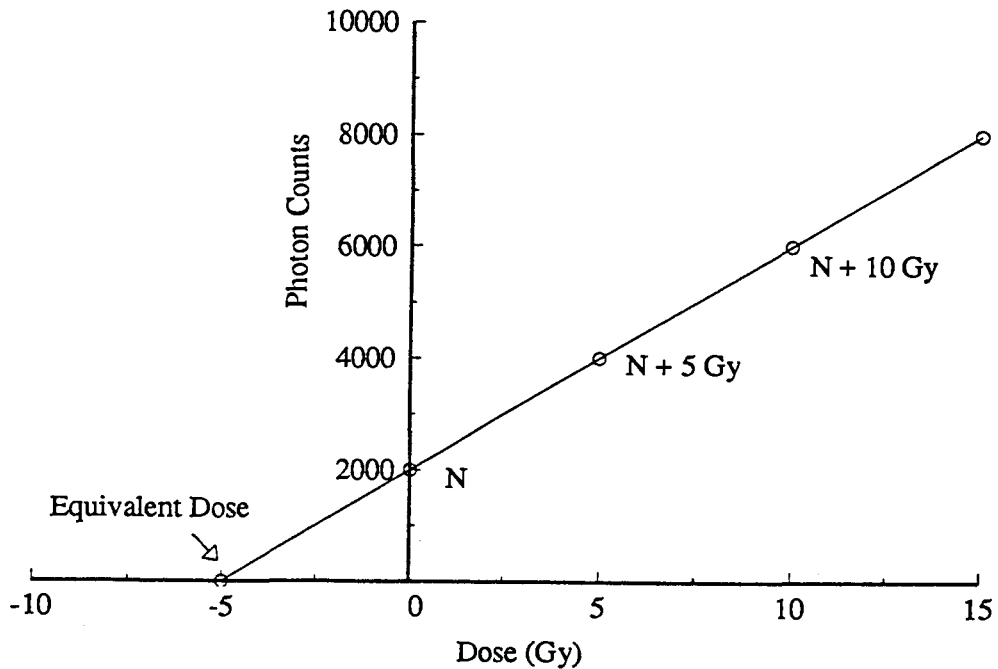

Figure 2.2: The additive dose method for TL dating. The sums of photon counts for a temperature range corresponding to a "TL peak" (eg. 370-380 °C) for a sample are plotted against the dose added to the sample. The equivalent dose is then found by extrapolation.

equivalent dose (see *Figure 2.2*).

In order to make the dose-rate calculation tractable it is normal to separate from the sherd either "fine grains" (all 2-8 μm diameter grains) or "coarse grains" (ca. 100 μm , or larger) of either quartz or potassium feldspars. The choice will depend on what the sherd contains, and provides the possibility of obtaining more than one date on the sherd.

2.1.2 The Dose-Rate

Mineral grains in a buried potsherd are exposed to three different types of radiation. Alpha particles, with ranges of less than 100 microns in pottery, come from decaying U and Th within the potsherd. If one uses large (>100 μm) grains (or "coarse grains") and etches them briefly in hydrofluoric acid (HF) (Fleming 1979:41-44), then the effect of alpha particles originating outside a grain is usually negligible. Beta particles have a range of 1 to 2 mm in pottery, and come mainly from the decay of U, Th and K within the potsherd. Gamma radiation has a range of about 30 cm in soil (Aitken 1985:72), and most of the gamma radiation dose comes from U, Th and K in the surrounding sediment.

Accurate determination of the dose-rate can be difficult. One principle source of error in a luminescence date is the uncertainty in the dose-rate contribution from the surrounding sediments; often called the environmental dose-rate. A potsherd, for example, has usually not been buried in a closed system, so the dose-rate may not have been constant. Different strata may have different dose-rates, and if the buried sherd changes location in the soil, it may have been exposed to different environmental dose-rates. In addition, water in the soil and sherd absorb some of the radiation energy, and radon gas from the uranium and thorium decay chains may escape, thereby

changing the dose-rate. Aitken (1985:68) estimates that in a potsherd, the fine grains (under 10 μm) receive about 25% of their total radiation dose from the environmental dose-rate, while coarse grains receive about 40%.

Evaluation of the dose-rate to a sample thus involves determination of the K, U, Th and water contents of both the sample and its surroundings, and a calculation appropriate to the grains used for the equivalent dose determination.

2.2 Thermoluminescence Dating of Unheated Sediments

In addition to heat, light can also release electrons from their traps. A number of researchers have dated aeolian and other sediments in geological contexts, reasoning that the grains should have been exposed to enough sunlight to significantly reduce their TL signal before they were deposited. This assumption is not always correct, as we shall see later. Most of the TL work done recently has been concerned with dating geological sediments, because of its potential to solve geological problems.

Much of the methods, principles, and terminology of unheated sediment dating are similar to TL dating of pottery, as the one evolved out of the other. In sediment dating both fine-grain and coarse grains can be used to determine an equivalent dose, and the dose-rate determinations are much the same as those already described.

The principal difficulties lie in the correct evaluation of the equivalent dose and proper allowance for the fact that sunlight exposure at deposition did not empty all the traps. The three main methods in use are as follows.

2.2.1 The Additive Dose Method

The additive dose method used for pottery requires that the sample's traps be empty at the time the pottery was fired. Godfrey Smith et al (1988) studied the effect of sunlight exposure on TL by taking a number of planchets with either quartz or feldspar grains on them, exposing them to direct sunlight for various lengths of time, and measuring the TL. The relationship is shown in *Figure 2.3*. After about 20 hours, the TL signal was only reduced by an order of magnitude. After this time the TL signal reaches an equilibrium level with no further noticeable reduction (Wintle 1993:627). The TL is never found to be reduced to zero by sunlight exposure, and so the additive dose method cannot be used alone to determine the equivalent dose. A simple variation, called the "total bleach" method, is sometimes used in which a portion of the sample is exposed to a long laboratory or sunlight bleach to determine the intensity of the unbleachable component (Singhvi et al 1982, Berger 1988:20, Aitken 1985:223). The TL intensity of the bleached samples is then used as a zero point when extrapolating the equivalent dose (see *Figure 2.4*). The principal problem with the total bleach method is that the sample may not have been exposed to much light at deposition making the equivalent dose estimation too great (Aitken 1985:223, Berger 1988:22).

Further information can be found in the TL sediment dating reviews of Wintle and Huntley (1982), Singhvi and Mejdahl (1985), and Berger (1988).

2.2.2 The R-Gamma Partial Bleach Technique

One way to avoid some of the potential problems inherent in the total bleach method is to use the partial bleach, or R- Γ method of Wintle and Huntley (1980). Two set of aliquots of the sample are prepared as for the additive dose method. One set is then given a short laboratory bleaching

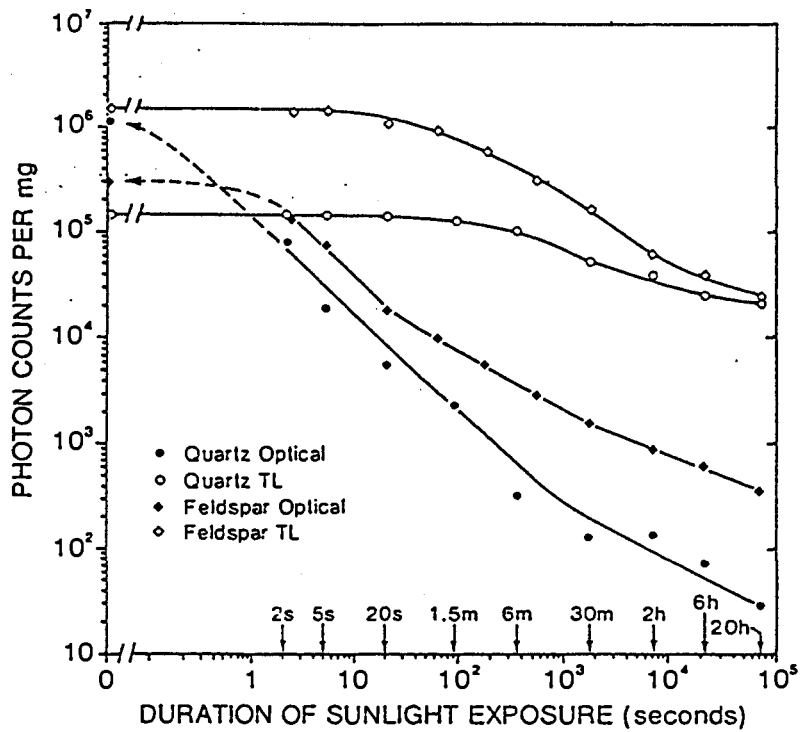

Figure 2.3: The effect of sunlight exposure on the optical and TL signals of quartz and feldspar. The unbleached values are shown along the vertical axis: each point represents the average of four samples, each normalized to its mass. The optical signal is that for one second immediately after the laser is switched on, measured at 10 mW/cm^2 for quartz, and at 15 mW/cm^2 for feldspar, using 514 nm as the exciting wavelength. Backgrounds were subtracted. The TL for quartz is at the well-defined peak at $320\text{-}330 \text{ }^\circ\text{C}$, and for feldspar at $310\text{-}320 \text{ }^\circ\text{C}$: these were obtained using a $5 \text{ }^\circ\text{C/sec}$ heating rate, and a 5-58 filter (from Godfrey-Smith *et al* 1988:375).

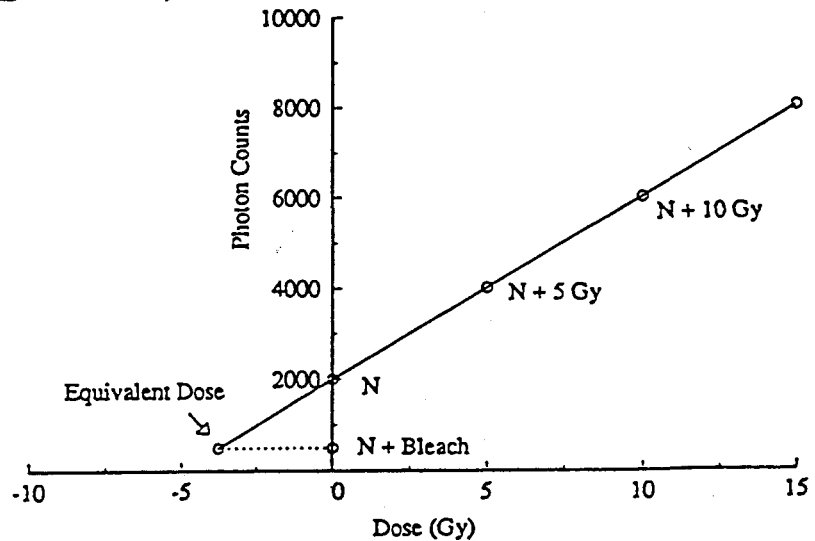

Figure 2.4: The total bleach method for TL sediment dating. The sums of counts for a temperature range corresponding to a "TL peak" (eg. $370\text{-}380 \text{ }^\circ\text{C}$) for a sample are plotted against the dose added to the sample. The "unbleachable" component of the TL signal is represented by the N+bleach point. The equivalent dose is then found by extrapolation as shown.

(a partial bleach). The TL intensity of both sets are then measured and the equivalent dose is found from the intersection of the two growth curves. The relationship is shown in *Figure 2.5*. One way of looking at this is that the 'reduction' in the TL due to the bleach results from emptying traps that are most easily emptied by sunlight exposure. These traps will have been emptied by even a short sunlight exposure in nature. A plot of this reduction vs. laboratory dose extrapolated to zero should yield the correct equivalent dose.

This technique avoids the problem of incomplete bleaching at deposition as long as the laboratory bleach is of shorter duration and intensity than the original bleaching, and the lab bleach does not change the sample's sensitivity.

2.2.3 The Regeneration Method

In the regeneration method (Berger 1988:20, Aitken 1985:223) some portions of the sample are kept as they are (the "N" set), and the rest are bleached by sunlight or a sunlamp until most of the traps that can be bleached are emptied. These bleached disks are then given various doses and form the N+bleach+dose set. The TL intensity of each disk is then measured and a growth curve is created, where the intensity is plotted against the added dose. The dose at which the curve has the same intensity as that of the natural samples is taken as the equivalent dose (see *Figure 2.6*).

There are two potential problems with this method. Firstly, like the total bleach method, the effect of the laboratory bleaching may be greater than that of the bleaching at deposition, thus leading to an equivalent dose that is too large. Secondly, the sample may have changed sensitivity when it was given the laboratory bleach; a test for this is essential.

If one combines the regeneration method and the additive dose method,

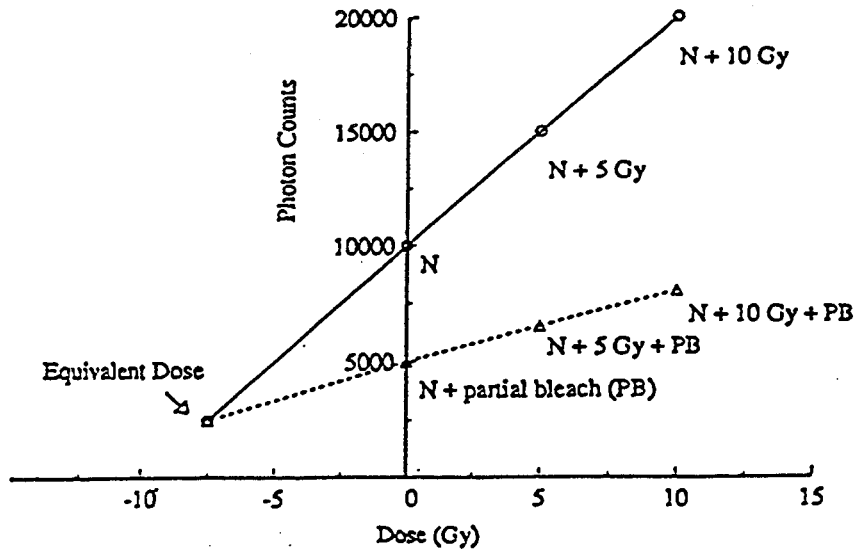

Figure 2.5: The partial bleach method. Some samples are exposed to a partial bleach after irradiation. The sums of photon counts for a TL peak are then plotted against their added dose. The point where the N+dose and the N+dose+PB extrapolations meet is the equivalent dose.

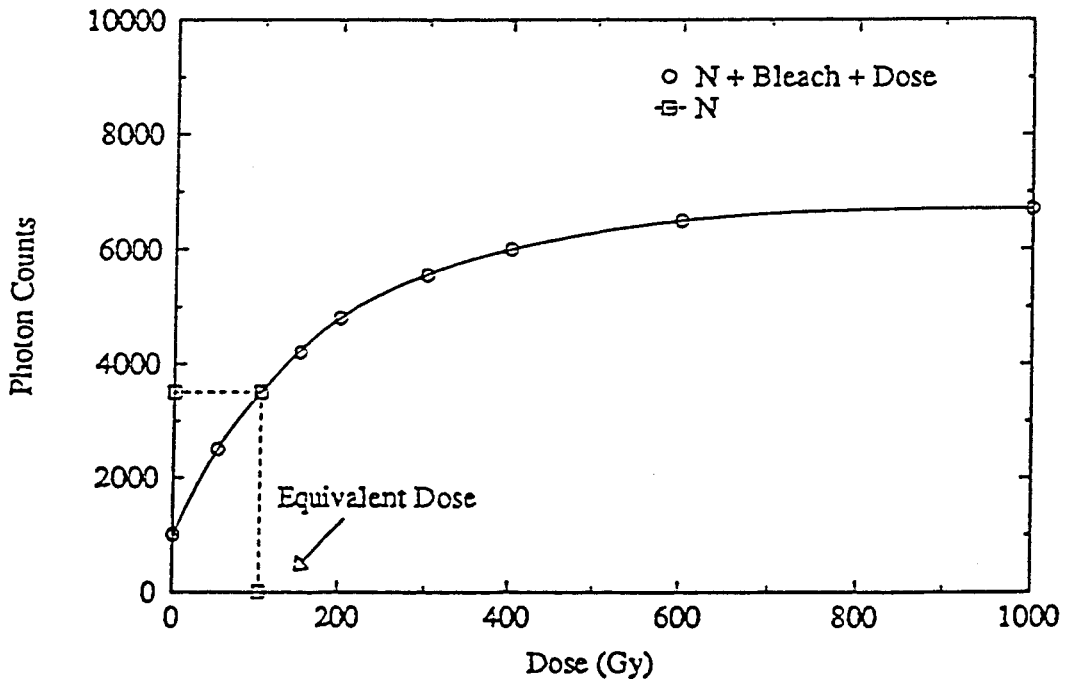

Figure 2.6: The regeneration method. Samples are bleached and then irradiated and measured. The sums of photon counts at a TL peak are then plotted against the added dose and a regeneration growth curve is formed. The intensity of the unbleached "natural" samples are then compared to the growth curve. The equivalent dose is the dose that would give a bleached sample the same intensity as the natural sample.

it is possible to test for a sensitivity change. The shape of the the additive dose growth curve is compared to the regeneration growth curve. If the two show the same shape then one may conclude that the regeneration samples did not change sensitivity due to the laboratory bleaching. The problem of overbleaching in the lab is addressed by determining an equivalent dose from a zero age, modern sample from the same sample region. See Huntley et al (1993a) for a successful application of this technique to dune sands from 8 dunes in south-east South Australia ranging in age from 120-800 ka.

2.3 Optical Dating

In 1985, Huntley et al (1985) published a paper entitled "Optical Dating of Sediments" in which they proposed a new method of dating sediments using light, instead of heat, to release trapped electrons. The idea was that if light can release the electrons initially at deposition, one can use light again to release the electrons that had been trapped since deposition. This technique has proven to be very successful, and avoids many of the problems inherent in using TL to determine an equivalent dose for unheated sediments.

Figure 2.3 shows one clear advantage optical dating has over TL dating for unheated sediments. A sunlight exposure of about 10 seconds reduced the optical signal from an old quartz to about 1% of its pre-bleached value; for the old feldspar sample a similar reduction was reached after about 9 minutes (Godfrey-Smith et al 1988:375). Each method is probably sampling different traps in the quartz and feldspar grains, and optical dating preferentially selects traps that are most easily emptied by sunlight. This means that one can use the additive dose and regeneration method (preferably together, as in 2.2.2) to determine an equivalent dose for samples where one is reasonably sure there was sufficient sunlight exposure at deposition. For wind-blown

sediments (eg. loess) it is probably safe to assume that the grains were exposed to sufficient sunlight, but for water-carried (fluvial) sediments one can not always be sure.

It is necessary in the measurements to measure the emission at higher photon energies than that of excitation in order to avoid measuring scattered incident photons and normal photoluminescence. The two schemes that are in common use are (a) the use of green photons (eg. from an argon laser) for excitation and measurement of blue and UV photons, and, (b) use of 1.4 eV (infrared) photons for excitation and measurement of the visible or UV photons. These will now be discussed in turn.

2.3.1 Argon Laser (2.4 eV) Excitation

The first light source used to measure the equivalent dose of a sediment sample was an argon laser (emitting at 2.4 eV, 514 nm); and it was used to date grains extracted from a silt from British Columbia (Huntley et al 1985). Their age of 62 ± 8 ka matched well with an associated radiocarbon date of 58.8 ± 0.3 ka. A laser was chosen because it is a convenient high-intensity source of photons of fixed energy.

Smith et al (1990) report good agreement between independently determined dates (eg. radiocarbon dating) and dates obtained from quartz grains extracted from sediments in the time range 0 to 140 ka collected from various archaeological and geological sites.

Stokes and Gaylord (1993) dated quartz grains using an Ar laser (emitting at 2.4 eV, 514.5 nm) from a sequence of Wyoming dune sands dated to between 0 and 8000 years old. His dates were in accordance with radiocarbon dates from the sequence. Stokes (1992) also has dated quartz grains extracted from young sediments.

2.3.2 IR Diode (1.4 eV) Excitation

It is possible to use infrared photons with an energy of 1.4 eV (880 nm) to evict trapped electrons from feldspar grains (Hutt et al 1988), while under the same conditions pure quartz grains show no response. This has allowed researchers to look specifically at the feldspar portion of sediments, which has a great advantage for dating very old samples (see *Section 2.6*). It is also more economical and easier to set up a measurement system using light-emitting diodes rather than a laser.

Aitken and Xie (1992) found agreement with independent dates for feldspar samples taken from 9 British archaeological sites ranging from 1000-5000 years old. Duller (1992) compared equivalent doses with those obtained using TL for samples from a New Zealand dune sand sequence. Spooner et al (1990) report a good agreement between a date of 1.9 ± 0.2 ka and a calendar age of 1.7 ± 0.05 ka, based on pottery from a Romano-British archaeological site. Ollerhead et al (1994) obtained ages ranging from 5 ± 30 years for a modern dune to 765 ± 45 years for the oldest dune, using feldspar grains extracted from a sequence of New Brunswick dune sands.

Huntley et al (1993b) and Short and Huntley (1992) have demonstrated that some quartz grains have feldspar inclusions in them that can be used to get an equivalent dose using 1.4 eV stimulation. This is of great use in dating very old samples, as feldspar has a much higher saturation dose than quartz (see *Section 2.6*).

Reviews of optical dating have been given by Aitken (1992) and Wintle (1993).

2.3.3 Single Aliquot Equivalent Dose Determination

Duller (1991) investigated the use of a single aliquot (disk) additive

dose method for determining the equivalent dose of a small sample. He used a disk covered with about 8 mg of 180-211 μm feldspar grains extracted from a known-age New Zealand sand dune to determine a single aliquot equivalent dose. The disk was exposed to an IR diode array for a very short time (0.5 s with a IR diode power of 32 mW/cm^2 on the sample). The disk was then preheated for 10 minutes at 220 $^{\circ}\text{C}$ and re-measured. Then the disk was given a beta dose, preheated and exposed to the diodes again. This latter process was repeated 4 more times with increasingly higher beta doses. The added doses were considered to be cumulative as the short diode exposure should not have drained many of the electron traps. The photon counts from each diode exposure could then be plotted against the cumulative added dose. The preheats do drain some of the deep traps, so a correction for intensity loss due to preheats had to be made. Duller did this by using another single aliquot which was preheated and measured as many times as the first aliquot, but was not irradiated. The intensity loss at each measurement point was calculated, and the first disk's intensity was increased at each point based on the calculated loss due to the preheat. He found that his single aliquot results compared favourably with multiple disk additive dose IR diode equivalent dose determinations and with the estimated geological ages of the dunes.

2.4 Preheats in Optical Dating

Huntley et al (1985) first recognized the need to heat optical dating samples before measurement (hence a "preheat"). Quartz and feldspar grains have a variety of traps with a wide range of trap energies and corresponding lifetimes. For example, the trap that corresponds to the 375 $^{\circ}\text{C}$ TL peak in quartz has been estimated to have a lifetime of greater than 10^8 years at 15 $^{\circ}\text{C}$

(Fleming 1969, 1979, cited in Aitken 1985:272). There are also traps with short lifetimes, ranging from a few days or years, to a few hundred years. These short-lifetime shallow traps (also called "thermally unstable traps") are not used in dating old samples as they have been emptied and refilled many times since deposition. However, when one gives a sample a laboratory radiation dose that is the same as the natural dose, many of these shallow traps are then filled in that sample but are empty in the natural sample. When these two samples are then measured the laboratory irradiated one would give off more light than the natural sample, as electrons in the shallow traps as well as the deep traps would be evicted by the incident light. It is therefore necessary to empty these shallow traps in laboratory irradiated samples. It is obviously not possible to leave these irradiated samples for hundreds or thousands of years until all the shallow traps are emptied, so instead samples are heated to empty out these shallow traps.

There is not an accepted standard preheat in use among luminescence dating researchers. For quartz, Stokes (1992) recommends a 16 hour 160 °C preheat, while Rhodes (1988) suggests a 5 minute preheat between 180 and 240 °C (from Wintle 1993:633). For feldspars, Spooner's (1993:175) experiments indicate a 4 hour 160 °C preheat is adequate, however, Ollerhead (1993) used a 5 day, 140 °C preheat for his feldspars. For feldspar inclusions within quartz grains, Huntley et al (1993b) used a 7 day 140 °C preheat.

2.5 Anomalous Fading

Anomalous fading is a serious problem for some sediment samples. If portions of these samples are given the same laboratory dose, with some being measured immediately and others after a storage period (eg. 1 month), the

first samples will be brighter than the second. The sample's high temperature TL intensity will have faded unexpectedly. It is important that samples be tested to see if this effect is present. Quartz grains are less prone to this effect than are feldspars, but both types of samples need to be tested (Berger 1988:24-29). Spooner (1993) gives a detailed discussion.

2.6 Age Limits of Luminescence Dating

The age limits for optical and thermoluminescence dating vary depending on the particular circumstance. The lower limit is determined by the sensitivity of the measuring apparatus, the intrinsic sample sensitivity, and the extent of sunlight exposure at deposition. The lowest reported ages are in the tens of years range. The upper limit is determined by the thermal lifetime of the trapped electrons and the fact that at large doses the traps become filled (saturated).

Samples which have approached saturation will not give off any more light when they are heated or stimulated by light in the laboratory no matter how much more of a radiation dose they receive. Aitken (1985:235) estimates that generally quartz can become saturated at around a dose of 100 Grays, while feldspars may become saturated at around 2000 Grays. At normal dose-rates these correspond to 50 ka and 1000 ka respectively.

3 The Diring Yuriakh Site

3.1 Site Stratigraphy

The Diring Yuriakh site excavation is very large by North American standards, covering an area of approximately 200m x 30m. Mochanov has made a substantial effort to understand the site stratigraphy. *Figure 3.1* shows the extent of the excavations and *Figure 3.2* and *3.3* are Mochanov's representations of the stratigraphy. Alekseev *et al.* (1990) independently report details of the site stratigraphy. The following summary of the stratigraphy is from the descriptions in Mochanov (1988) and uses the same strata numbers.

Stratum 1 is the deepest stratum at the site. It is composed of Cambrian limestone bedrock which extends from below the current level of the Lena River to about 150 metres above the river.

Stratum 2 is a 0.5 to 1 metre thick gravel layer which lies on top of this bedrock. The small cobbles and pebbles in this layer are in a gravel/sand/clay matrix and are composed mostly of quartzite. There are also flints, chalcedony, limestones, sandstones, granites, diorites and some vein quartz (10-15 %) in this layer.

Stratum 3 is a 15-20 metre thick sand layer. At most areas of the site these sands are red, and at others they have a yellow or green tinge. There are a number of pebbles in this stratum, but only in large lenses. These sands are bedded, and Mochanov suggests they were deposited fluviially. He also emphasizes that "...syngenetic frozen textures and structures are entirely lacking..." in this "red sand" layer (Mochanov 1988:28).

Stratum 4 has disappeared from this site except where it is preserved

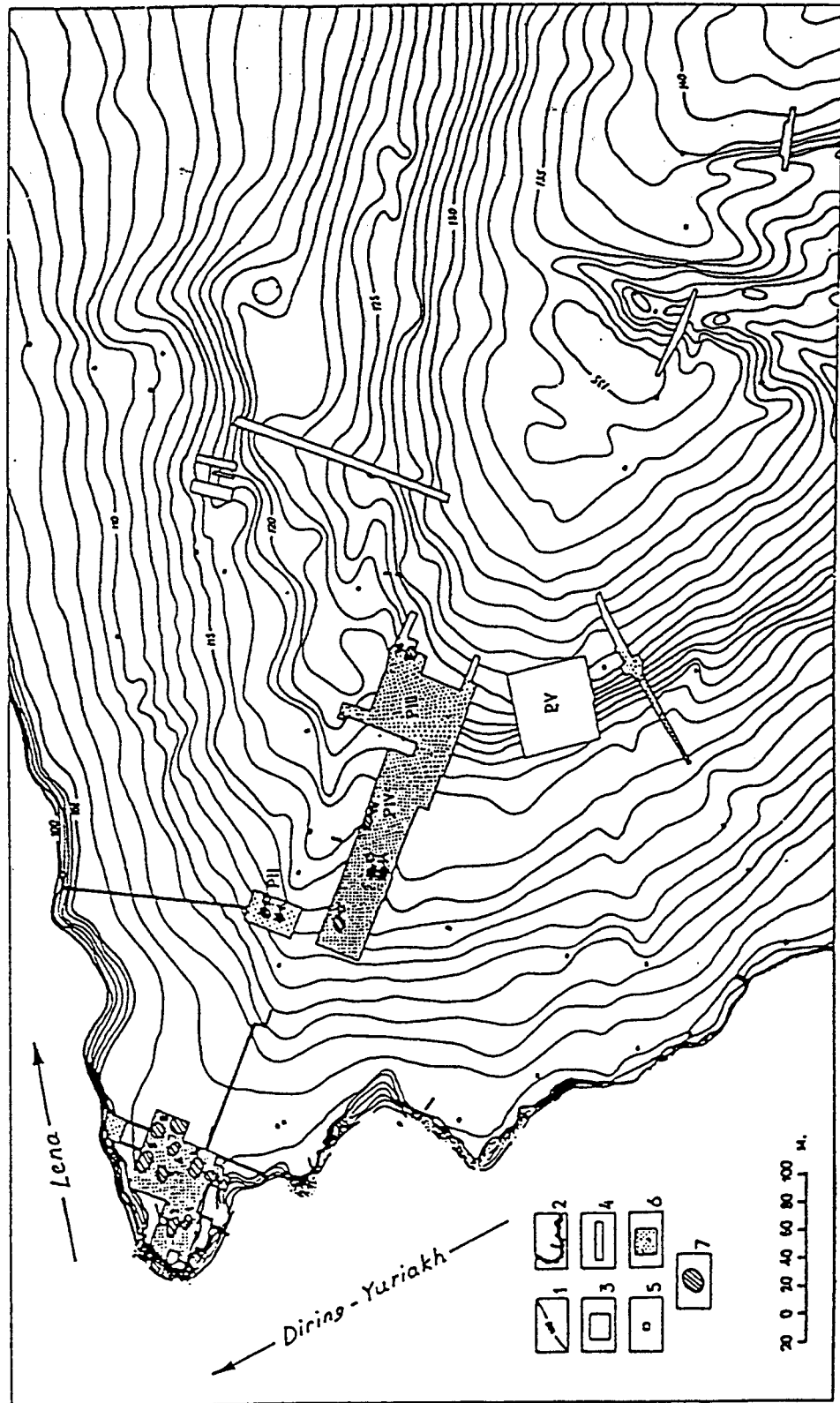

Figure 3.1: The extent of the Diring Yuriakh excavations. (1) Contour lines show the elevation above the Lena river in metres; (2) The Tabaginsk terrace; (3) block excavations; (4) trenches; (5) test pits (6) areas where stratum 5 was exposed; (7) stratum 5 artifact clusters (after Mochanov 1988).

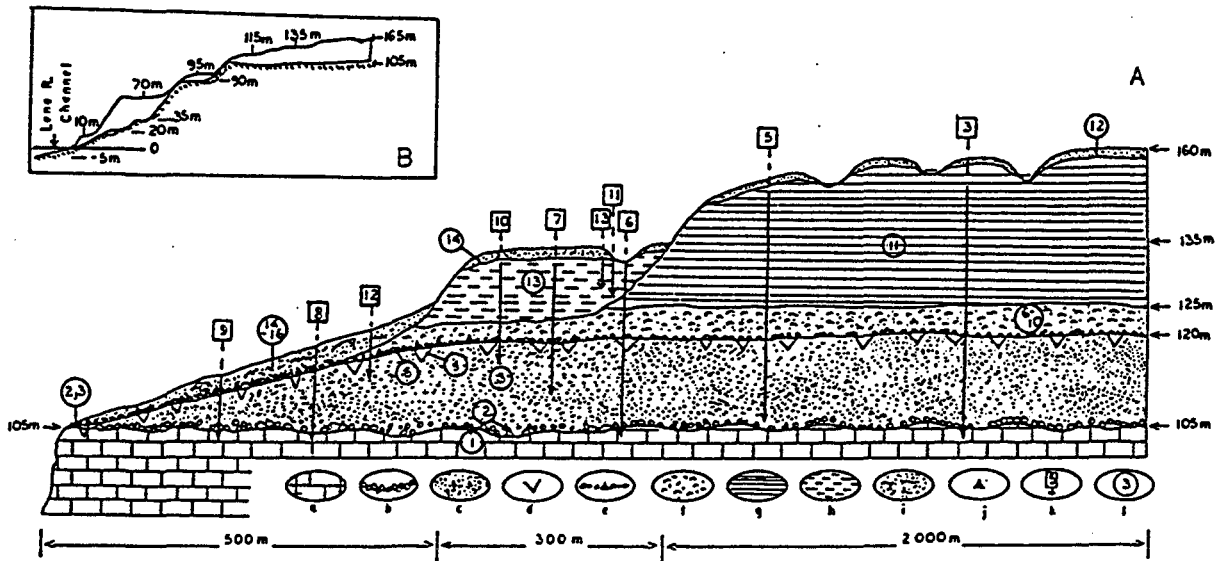

Figure 3.2: The Diring Yuriakh stratigraphy. (1) stratum 1 bedrock; (2) stratum 2 pebbles; (3) stratum 3 sand; (4) stratum 4 in ice wedges; (5) stratum 5 artifact layer; (6) strata 6-10 sandy, sandy loams, and loams; (7) stratum 11 sandy loams and loams; (8) stratum 13 sandy loams and loams; (9) strata 12, 14-16 sands; (10) stratum 5 artifacts; (11) drill cores; (12) strata numbers. Not to scale (after Mochanov 1988).

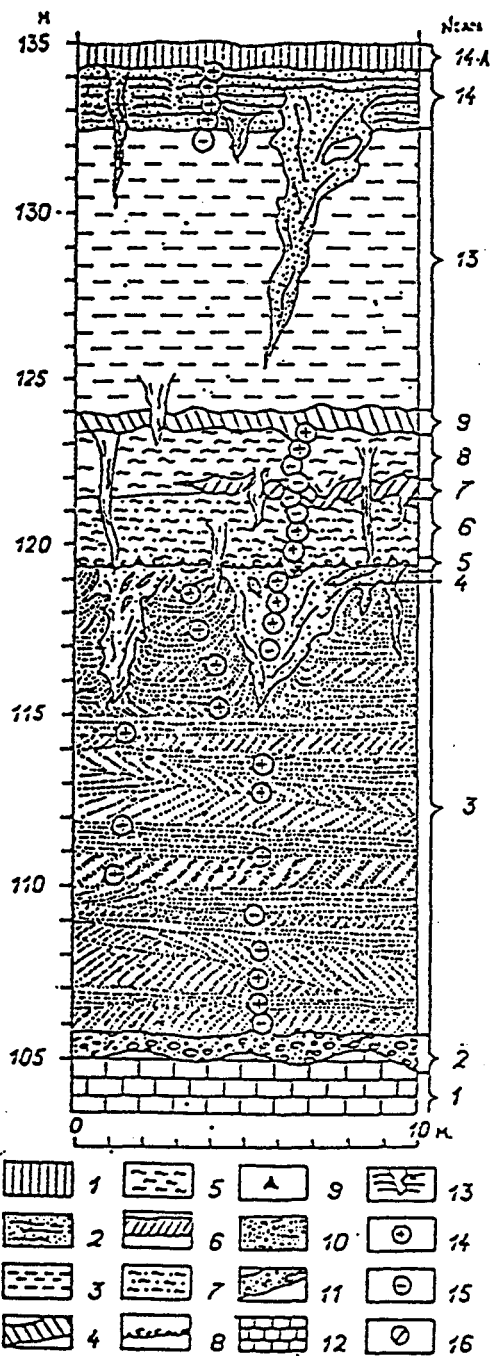

Figure 3.3: Diring Yuriakh summary stratigraphy. (1) present day soil; (2) stratum 14 sands; (3) stratum 13 sandy loams and loams; (4) stratum 9 loams; (5) stratum 8 sandy loams; (6) stratum 7 sandy loams and loams; (7) stratum 6 sands and sandy loams; (8) stratum 5 artifact layer; (9) stratum 5 artifacts; (10) stratum 3 sands; (11) stratum 2 gravels; (12) stratum 1 bedrock; (13) frozen structures; (14) sediments with normal polarity; (15) sediments with reversed polarity; (16) sediments with anomalous (out of sequence) polarity. Not to scale (after Mochanov 1988).

in the remnants of ice wedges. The latter were created when water seeped into stratum 3 and was then frozen. Repetition of freezing and melting expanded the ice wedge which was later filled in with stratum 4 sediments. When stratum 4 was removed by an unknown erosional process only the parts of it that infilled the ice wedges remained. The largest of these wedges are 5 m wide, and 4 m deep, and the smallest are only 0.5 m wide or less. The sediment in these wedges is described as a grayish-yellowish sand without any cobbles or large pebbles.

Stratum 5 is the important layer that contains artifacts. It is a layer composed entirely of pebbles, gravels and cobbles that lie directly on top of strata 3 and 4. Mochanov states that this is a deflation layer, which was created when wind removed sand-sized and smaller particles leaving only the heavier gravels pebbles and cobbles, which eventually came to rest on top of a surface that was resistant to wind erosion. Mochanov states that stratum 4 eroded away and all of the stones in this layer were deposited on top of the more resilient stratum 3. Mochanov notes that there are no cobbles in stratum 3, and so the cobbles in this layer must have come from above. The pebbles are well polished, with pits that are evidence of wind abrasion, adding weight to the deflation layer hypothesis.

The petrographic composition of these stones is "...65-70% siliceous rock; 20% quartzite; and 10% vein quartz. The majority of the large pebbles and almost all of the cobbles are quartzite" (Mochanov 1988:30). Presumably, people used these surface lithics as raw material for tools. The artifacts occur in discrete clusters about 10-30 m² (1988:32) in area. Mochanov remarks on the remarkable preservation here, as he could often refit flakes to cores, and in some circumstances he could refit nearly complete cobbles.

The artifact layer is then covered in most places by *strata 6-9*.

These strata are composed of horizontally bedded greyish-orange sands and loams with some small ice wedges and possibly evidence of paleosol formation. These sediments were deposited fluviially (Mochanov 1988:37).

The upper strata, *strata 6 to 16*, are not all present in all parts of the site. At one part of the site stratum 14 directly overlays stratum 5.

3.1.1 Interpretation of the Site Stratigraphy

Alekseev et al (1990) have divided up these sediments into two distinct formations. The first formation contains the stratum 2 pebbles and the stratum 3 reddish sands. The sands were bedded, leading them to deduce that the sands formed in an alluvial (river) environment. Due to the lack of ice or frost features in the strata, and because they believe the red sand was a relic of a thick pedsollic soil, they conclude that the climate of the time was warm and humid (Alekseev et al 1990:12).

There was a long break between the two formations, during which the soil formed in stratum 3. Then the climate became much colder and harsher and the strata 4 sand veins were created. The evidence for this worsening climate is as follows:

"...sand veins [stratum 4] could have formed only at the presence of the permafrost rocks with the average annual temperature not lower than -6, -8. The average air temperature must have been lower than -12, -14 with low snow cover in winter and strong winds which transported dry sand filling frost fissures...[tool-making using stratum 5 pebbles] was carried out after both layers [4 and 5] had formed and when [the] climatic environment had softened."

Alekseev et al (1990:26)

As was noted above, Mochanov believes stratum 5 was formed when wind carried away the sediment above stratum 3 and left only the heavier pebbles and rocks on top of stratum 3 and on stratum 4 in the ice wedges. Alekseev et al agree with Mochanov's interpretation here, and add that they also observed evidence of wind abrasion on the stratum 5 pebbles. They also note that the

sand matrix between the stratum 5 pebbles was very similar in composition to the stratum 4 sediment (Alekseev et al 1990:13).

After the artifacts were created using the stratum 5 pebbles, strata 6 to 9 (called the "ochreous" layer) were deposited fluviially. The mineral composition of these strata is very different from stratum 3, but similar to stratum 4. Alekseev et al (1990:16) note that strata 6-9 are "...a variety of periglacial alluvium accumulated in cold climatic environments. The cycles of alluvial accumulation of sediments alternated with long periods of soil-forming processes..."

The upper strata 10-11 (the "loams") and 12-16 (the "grey sands") were formed in a cold periglacial environment, with some portions laid down by water and others by wind (loess) (Alekseev et al 1990:16-20). Of these upper strata, only stratum 14 is of concern to us, since at one area of the site stratum 14 was deposited directly on top of stratum 5, any intervening strata having been eroded away. Mochanov (1988:35) notes a thin paleosol between stratum 14 and stratum 5. The composition of stratum 14 is very similar to the other upper strata, with horizontal beds which are evidence of a fluvial deposition. How the erosion of the upper layers down to stratum 5 occurred is unclear.

3.2 The Dating of the Diring Yuriakh Strata

We will now turn our attention to the controversial dates that have been proposed for key sections of the Diring Yuriakh profile. We will first consider Mochanov's dates, and the reasons why he has proposed them. Then we will consider Alekseev et al's dates, especially where they are in conflict with Mochanov's.

Mochanov uses three types of evidence to arrive at his dates;

palaeomagnetic data, palaeoclimatic data, and 'radiothermoluminescent dates'.

We will consider each of these in turn.

3.2.1 Palaeomagnetic Data

Palaeomagnetic dating studies of the Diring Yuriakh stratigraphy were undertaken in 1986 by A.K. Pen'kov. The basic premise behind palaeomagnetic dating is that particles that are affected by a magnetic field (eg. magnetite) will be laid down in gently deposited sediments (eg. lacustrine) with a net tendency of the magnetization of these particles to become oriented in the direction of the field, resulting in a magnetic moment in the direction of the earth's magnetic field (the exact mechanism is poorly understood) (Aitken 1974:176).

In the past the north and south magnetic poles of the earth have interchanged, resulting in a reversal of the direction of the earth's magnetic field everywhere on earth. A magnetic epoch is a period of time during which the field has been predominantly in the same direction for a relatively long period of time. The current magnetic epoch is called the Brunhes epoch. The polarity was reversed for the previous Matuyama epoch, the transition between these two having been dated to about 780,000 years ago using potassium/argon dating (Spell and McDougall 1992). There are several short periods of normal polarity during the Matuyama epoch. Palaeomagnetic information yields only a choice of dates for the user and additional information is usually required to make a selection from the choice.

A major problem with palaeomagnetic dating is the occurrence of non-global reversals that are found only in certain areas. The Lake Mungo reversal in Australia, dated to ca. 30,000 years ago (Aitken 1990:242) is an example of such a reversal.

A researcher who finds a number of reversals in a stratigraphic

sequence may have no way of knowing which reversals are which. If there is an independently dated sequence from a nearby area with similar sediments then one may be able to make correlations, but these 'type' sequences are rare. Also, one cannot always know whether or not a stratigraphic sequence is complete.

At the Diring Yuriakh site the problems with using palaeomagnetic data are highlighted. There is no regional dated reversal sequence for this part of Siberia, so the researchers have no way of knowing whether the reversals they may see are due to the Brunhes-Matuyama reversal, a reverse-normal transition within the Matuyama, or an unknown reversal restricted to this part of Siberia.

Mochanov (1988) gives us the results of Pen'kov's 1986 palaeomagnetic data (see *Figure 3.3*), but does not give us any of the details of how the dates were arrived at:

"...the most probable palaeomagnetic chronological limits of culture-bearing Stratum 5 are these dates: 4.2-3.9 million years (Stratum 3) and 3.15-3 million years (Strata 6, 7, and 8). A variation is possible as well: 3.4-2.9 or 2.5 million years. At present a "minimum" variation also cannot be excluded: 1.9-1.7 million years. The younger variations are not as probable." (Mochanov 1988:39)
Alekseev et al (1990) also report their own palaeomagnetic data for

the Diring Yuriakh site. They report finding "normal" (same as today) magnetization for the whole stratigraphic sequence except for a reversal in strata 6-9 (Alekseev et al 1990:27, figures 8-11). This apparently is the reversal that Mochanov and Pen'kov have assumed is either the Gauss-Matuyama transition or the Mammoth episode within the Gauss epoch (Alekseev et al 1990:27). Alekseev et al see this reversal as "...one of the episodes or a digression of the early Brunhes epoch." (1990:27).

3.2.2 Radiothermoluminescent Dates

At the 45th Annual Northwest Anthropology Conference, Mochanov handed out a paper entitled "The Earliest Palaeolithic of Northeastern Asia and the Problem of the Extratropical Cradle of Man" which summarized his work on Diring Yuriakh. In this paper Mochanov presented the results of "Radiothermoluminescent" (thermoluminescence) dates undertaken by O.A. Kulikov at Moscow University. Dates of more than 1.1 million years B.P. for stratum 6 (RTHL-453), 2.9 ± 0.96 million years B.P. for stratum 5 (RTHL-424) and older than 1.8 million years for stratum 4 (RTHL-454) were given (Mochanov 1992:4). No details about how these dates were determined were presented and no researchers have demonstrated that they can obtain correct ages of this great antiquity, so it is unwise to place any reliance on them. Also, as we have seen in the previous chapter, it is crucial that the sediments be exposed to sufficient sunlight at deposition in order for a TL age to be valid. As yet, there is no reason to believe that sufficient sunlight exposure occurred for these sediments.

3.2.3 Palaeoclimatic Data

The other line of evidence used by both groups of researchers is palaeoclimatic data. They both agree that in the first formation, strata 1-3, there are no stratigraphic features that can be attributed to a cold climate, but that there are many in the upper formation (strata 4-16). They both believe that in the time between the formation of strata 3 and 4, the climate went from being warm and humid to cold and (peri)glacial. Analysis of pollen found in sediment cores supports this conclusion. The problem is dating this climate change. Is this the change between the warmer Pliocene (ca. 5 to 2 million years ago) and the colder Pleistocene (ca. 2 million years ago to present), or is the warm period one of the several interglacials that occurred

during the Pleistocene?

Alekseev et al do see the lower formation as being formed in the Pliocene, then, after a long period of time, the upper formation was formed wholly within the Pleistocene (Alekseev et al 1990:26). Strata 4 to 9 are placed within the Lower Pleistocene due to the cooling climate, while strata 10 and above were formed within the Middle Pleistocene. It is unclear how they made the lower/middle Pleistocene distinction.

Alekseev et al's dates do conflict with Mochanov's, as he sees the break between the two formations as being between 4 or 3 million years ago. He also sees strata 6 to 9 as being within the Pliocene as well. It is clear to all researchers involved, including Mochanov, that more accurate dates are required before the age of the stratum 5 artifacts can be determined.

4 The Classification and Mineralogy of the Quartzite and Sample Preparation

Mochanov (1988) and Alekseev et al (1990) both identify the pebbles in stratum 5 and 2 as being predominantly quartzite.

This chapter contains a discussion of the classification of the quartzite, the results of some X-ray diffraction (XRD) work undertaken to determine the mineral composition of the pebbles, and sample preparation procedures.

4.1 The Classification of Quartzite

Hurlbut and Klein (1977:473) define quartzite as a general term for a rock, composed mostly of quartz, that is formed when sandstone is metamorphosed. In this process the silica may go into solution and become redeposited making a very compact rock composed of interlocking quartz grains.

Ebright (1987) discusses quartzite petrography and its potential applications to archaeology. She provides a useful introduction to quartzite classification and provides a more clear and precise definition of the different types of quartzite. Ebright's classifications are as follows.

Quartzites can be divided into two types; metaquartzites and orthoquartzites.

Metaquartzites are rocks that have been completely restructured by metamorphosis so that the original grain shape, size and inclusions have been completely eradicated and reformed. It is possible to see deformation features such as grain elongation and the appearance of strain marks. Metaquartzite grains tend to be clear while orthoquartzite grains may appear

cloudy (Ebright 1987:32).

Orthoquartzites form a continuum of types from the most immature called "silicified sandstone" to Type I and II orthoquartzites, and finally to "pressolved" quartzites. Silicified sandstones are composed of unaltered rounded sand grains that are held together solely by secondary silica cement. The more mature Type I orthoquartzites have some secondary quartz growth, within which the quartz grains have increased in size. The grains are still held together by the secondary growth cement (often opal or chalcedony). In Type II orthoquartzites the grains have grown together, and the cement may be completely absent. Type II orthoquartzites are more common than Type I. The final pressolved quartzite represents the "...end stage in the development of a sedimentary quartzite from an original sandstone" (Skolnick 1965:15 in Ebright 1987:31). These last orthoquartzites have been affected by pressure from normal rock formation processes and there is a high degree of compaction, homogenization of grains and some grain elongation is possible.

Despite the popular definitions, "...the vast majority of quartzites in existence are orthoquartzites" (Krynine 1948 quoted in Ebright 1987).

4.2 The Classification of the Diring Yuriakh Quartzite

Three Diring Yuriakh quartzite sample were studied to determine their structure and composition: DY-1a, DY-1b and a portion of DY-32, from stratum 2 (see Appendix B for a sample list).

These three samples were classified using the qualitative quartzite classification scheme from Ebright (1987) presented above.

DY-1a (from cross-sections) was composed of large clear quartz grains in a light brown cement. There were some streaks of black. A definite banding and elongation of the grains was noted. After separation of some

quartz grains using hydroflouric acid it was found that there were both clear and cloudy grains. This is most likely a Type II/pressolved orthoquartzite.

DY-1b (from cross-sections) looked very similar to DY-1a, except the clear quartz grains were much smaller, and there was no clear evidence of banding or grain elongation. This is probably a Type II orthoquartzite.

DY-32 (from a cross-section) was unlike DY-1a and DY-1b. There were clear and cloudy quartz grains in a white/brown matrix with some black specks. There was no evidence of banding or grain elongation. This was probably a Type I orthoquartzite.

4.3 X-Ray Diffraction Experiments

Portions of DY-1a and DY-32 (from stratum 2) were crushed in a mortar and pestle, powdered in a ring mill, and measured using an X-ray diffractometer. The resultant XRD spectra are shown in *Figures 4.1a-c*. They were analyzed by comparing their spectra to spectra of known samples, by determining the lattice spacings for each peak and comparing them with the lattice spacings for different minerals given in a compendium published by the International Centre for Diffraction Data.

Three separate portions of the DY-1a sample were prepared. The outer layer, the inner portion, and quartz grains separated out using hydrofluoric acid. The XRD spectra of the three samples were almost identical, and almost the same as the Ottawa sand (quartz) standard spectra (see *Figure 4.1a,b*). Therefore, it was deduced that DY-1a is composed almost entirely of quartz.

The DY-32 spectrum showed the presence of quartz, but also contained additional peaks that were matched with albite, a type of feldspar (see *Figure 4.1c*).

One of the features of the luminescence results to be described is the

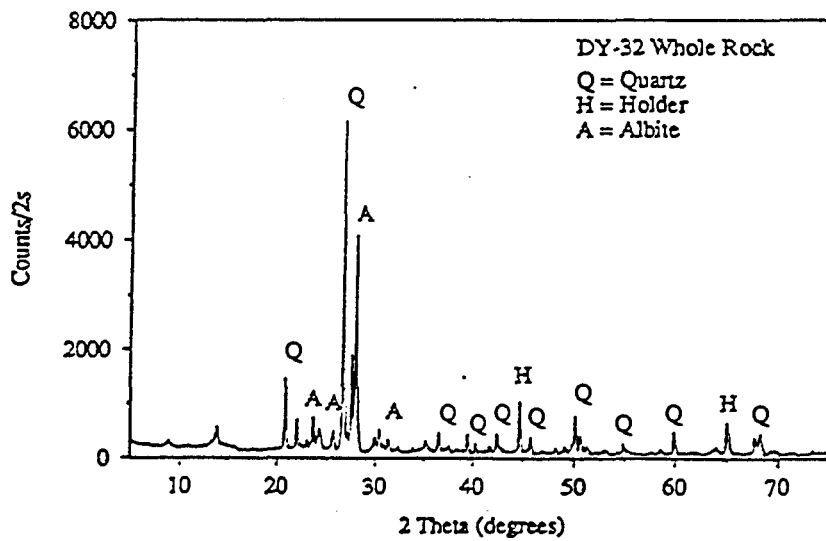
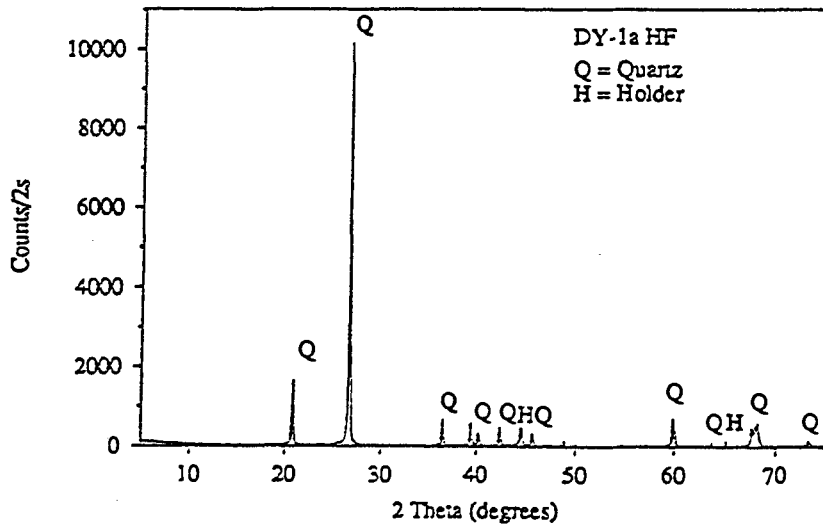
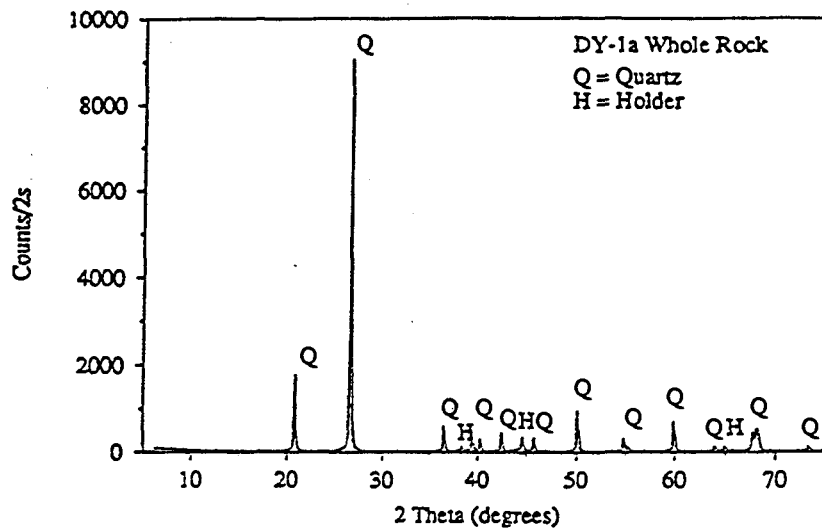

Figures 4.1a-c: X-ray Diffraction spectra from DY-1a whole rock (a), grains removed from DY-1a with HF (b), and DY-32 whole rock (c). Samples were first powdered in a ring mill. CuK_α radiation was used.

variety found amongst the different samples; it is therefore likely that the above limited analyses did not reveal the range of the quartzites present.

4.4 Extraction of Quartz Grains using Hydrofluoric (HF) Acid

As quartzite is composed mostly of quartz grains embedded in a silica (opal or chalcedony) matrix, it seemed possible that one could use hydrofluoric (HF) acid to eat away this cement matrix and separate out the larger quartz grains, leaving them mostly intact. A number of experiments were undertaken with the DY-1a quartzite to test this hypothesis.

A small (1cm x 1cm) piece of DY-1a was put into a Nalgene beaker, and 48% HF was added to the beaker until the rock was covered. After 10 minutes the sample was rinsed with water and examined under a microscope. The brown rock appeared lighter in colour and a few small grains were in the bottom of the beaker. The rock and HF were then put back into the Nalgene beaker for 30 minutes. The sample was much lighter in colour now, and there were many clear crystals in the bottom of the beaker. The rock and HF were put back into the beaker for another hour. The rock was mostly white after this time (cumulative HF exposure was 1 hour, 40 minutes) and there were many clear, and a few frosty, grains in the bottom of the beaker.

To test the possibility that the cement may be calcite, another piece of DY-1a was put into a Nalgene beaker with enough 3% Hydrochloric acid (HCl) to cover the sample. After 1 hour and 10 minutes no reaction between the rock and the HCl had been observed.

It was decided that a 30 minute 48% HF treatment would be the standard way to remove quartz grains from these quartzite samples. After each HF treatment the grains were removed and the quartzite was washed in distilled water before being put back into HF. The grains were also washed in distilled

water before some 10% HCl was added to the grains for a few minutes to remove any precipitated fluorites.

The grains from each treatment were kept separately, and each set of grains was called an "HF layer". This was a convenient way to compare the luminescence responses of grains at different depths of the rock. It was also done to ensure that the quartz grains only received about 30 minutes of HF exposure. Bell and Zimmerman (1978) observed that HF does etch away parts of the quartz grains after 40 minutes, but not uniformly. 30 minutes seemed to be a convenient etching time, and longer etches might have removed too much of the grains.

In order to determine how much sample was removed from a quartzite sample per HF treatment the mass and dimensions of DY-32 was measured before and after a series of HF treatments. After removing 10 HF layers it was found that, on average, each HF treatment etched away 0.25 mm of the rock (on one surface). Of the total 15.7 g removed from the rock, only 1.59 g of quartz grains were recovered; 10 % of the mass removed is recovered in quartz grains.

To see if the HF treatments were removing discrete layers of sample or were also etching portions of the rock interior, some relatively simple volume calculations were made for the inner portion of DY-32. Before the HF treatments, the sample had a volume of approximately 7.6 cm^3 and a mass of 17.30 g. Therefore, the density was approximately 2.28 g/cm^3 (compared to the density of 2.65 for pure quartz (CRC Handbook of Chemistry and Physics 1984:B-201)). Using this density, and a volume after the HF treatments of 3.76 cm^3 , the mass of the sample should have been 8.57 g. The actual mass was 7.54 grams. These values are quite similar, and it was concluded that the HF treatments take off discrete layers from the outside of the rock and only a minor fraction of the grains come from the inner portion.

4.5 Disk Preparation

To prepare the samples for measurement, HF-treated quartz grains were sieved to select the desired size range. Then (usually) about 10 mg of quartz grains were put onto 1 cm diameter aluminum disks coated with a thin layer of silicone oil (Dow Corning 200 fluid). All preparations were carried out in subdued light.

5 Luminescence Experiments

There are two basic questions that need to be addressed concerning the possibility of using the quartzite for luminescence dating. Firstly, would quartz grains extracted from the quartzite behave like quartz found in sediments? Secondly, if so, will sunlight penetrate a rock sufficiently to bleach the quartz grains so that luminescence dating techniques developed for sediment dating can be applied?

In this chapter the results of experiments conducted to address the first of these questions will be presented. The second question will be addressed in *Chapter 6*.

The equipment used to carry out luminescence measurements is described in *Appendix A*.

5.1 Luminescence Characterization

The simplest way to see if these quartz grains were going to behave like sediment quartz and could therefore be used for luminescence dating was to study their TL and their response to 2.4 eV (Ar laser) and 1.4 eV (IR diode) stimulation.

In summary, we found a great variation in luminescence responses of the quartzites; each one responded differently. This complicated the understanding of the quartzites as it was unclear whether it was possible to apply the results of an experiment from one quartzite to another.

5.1.1 TL Responses

Three HF layers were taken off DY-1b (stratum 2) yielding about 440 mg of quartz grains. These grains were not sieved, so all grain sizes were kept together. The thermoluminescence glow curves, shown in *Figure 5.1a*, are similar to those normally found for quartz. Added doses of 30 and 300 Gy made little difference to the TL above 300 °C. A two hour sunlight exposure reduced the TL at 350 °C by about 90%. All this is similar to what is expected for old quartz.

The TL of 150-180 μm quartz grains from HF layers 8-11 from DY-1c (stratum 2) are presented in *Figure 5.1b*. The shape of the glow curve was similar to DY-1b's, but a 2 hour sunlight exposure only reduced the TL at 350 °C by about 50%. An 8 hour sunlight exposure reduced the TL at 350 °C by about 90%

The TL glow curves of 150-250 μm quartz grains from HF layers 2,3,4, and 6 from DY-31 (stratum 2) are shown in *Figure 5.1c,d*. The untreated ("natural") samples were similar in shape to DY-1b and DY-1c, but the irradiated samples were quite different. The peaks at 200-225 °C exhibit first order kinetics characteristics, while the peaks between 375 °C and 400°C exhibit second order kinetics characteristics. These are rarely observed, except in commercially prepared samples (eg. lithium fluoride). A 13 hour sunlight bleach reduced the TL at 350 °C by about 50%. The TL emission spectra are shown in *Appendix C*.

5.1.2 Responses to 2.4 eV (Ar laser) Excitation

A convenient way to characterize the response to 2.4 eV excitation of quartz is to calculate the % decay per unit incident energy for the initial part of the shine-down curve (the luminescence intensity vs. time). The usual

(a)

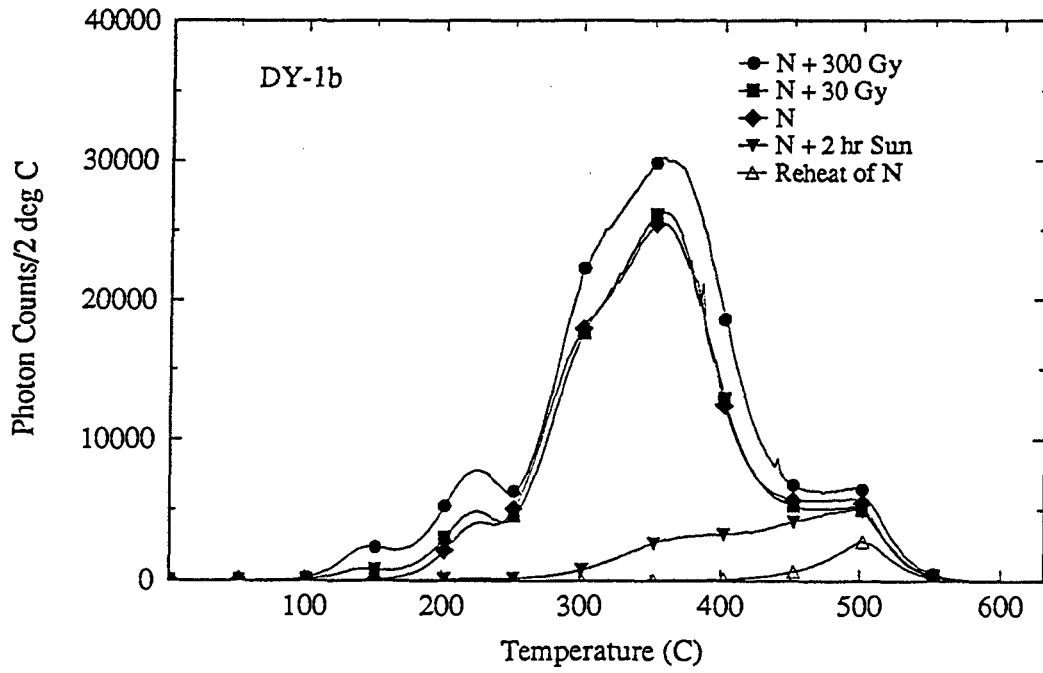

(b)

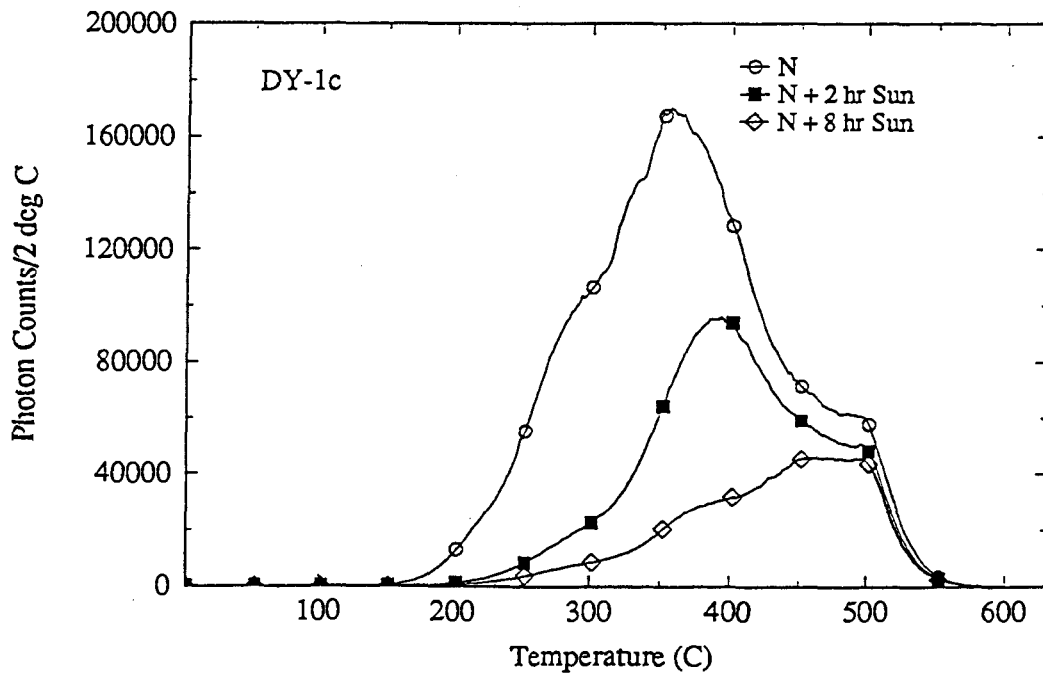

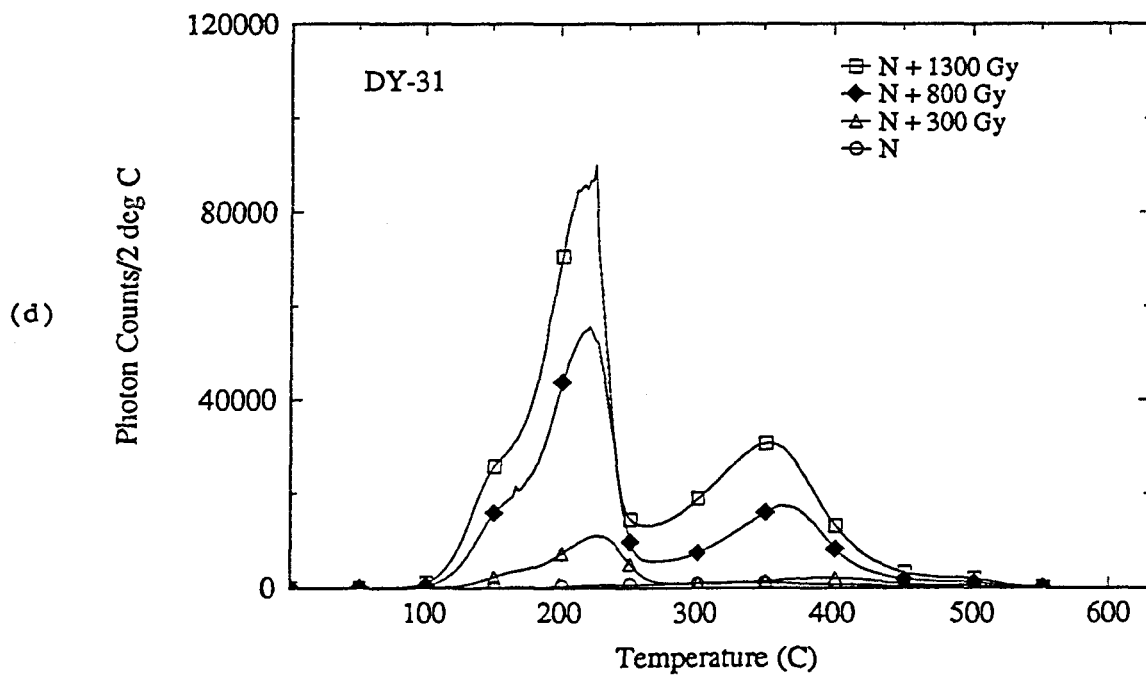
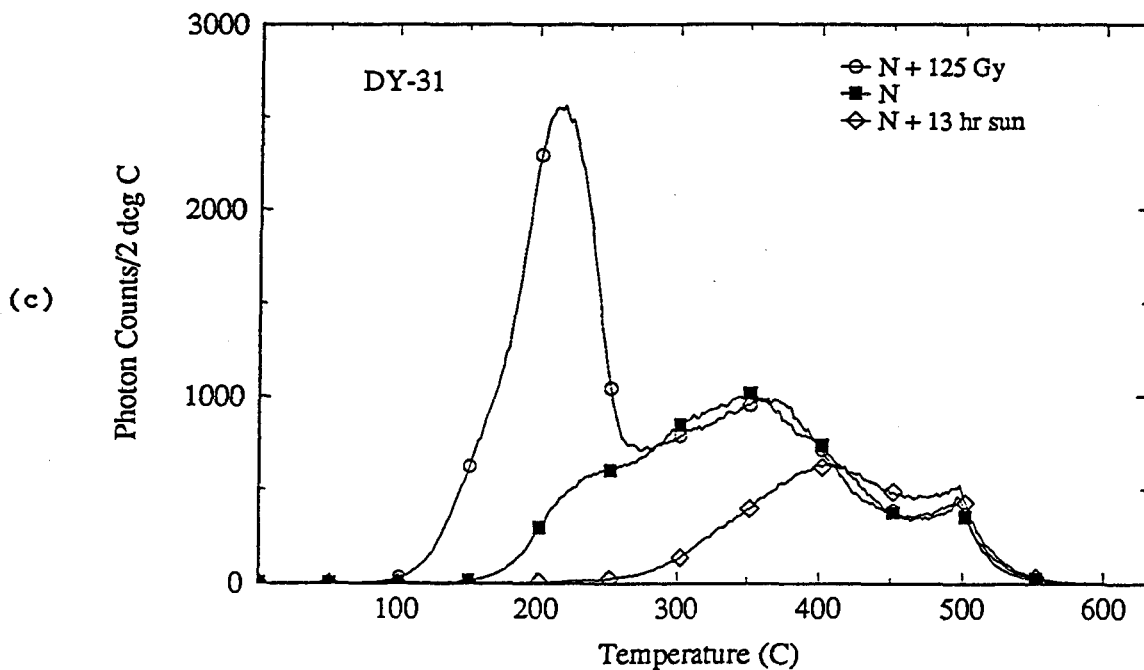

Figures 5.1a-d: TL glow curves from DY-1b (a), DY-1c (b), and DY-31 (c,d) showing the variation between samples. 10 mg aliquots were used for DY-1b and DY-1c, while 6.5 mg aliquots were used for DY-31. The DY-1b grains were unsieved, the DY-1c grains were 150-180 μm in diameter, and the DY-31 grains were 150-250 μm . The heating was at 5 $^{\circ}\text{C}/\text{s}$ to 500 $^{\circ}\text{C}$. See Appendix A for measurement equipment details.

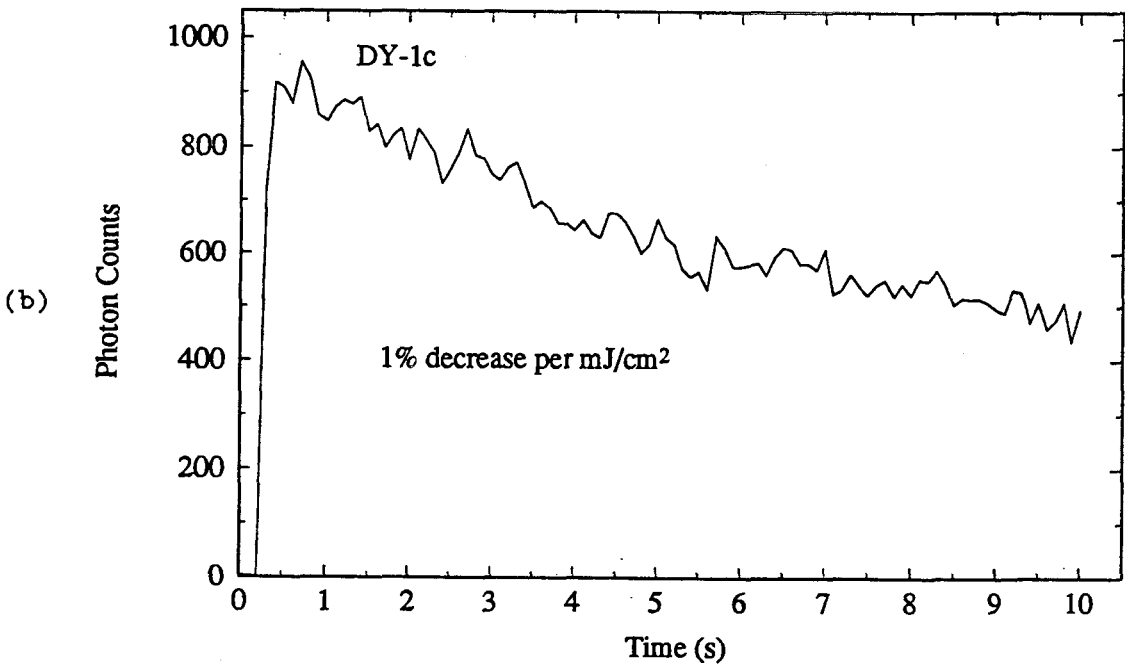
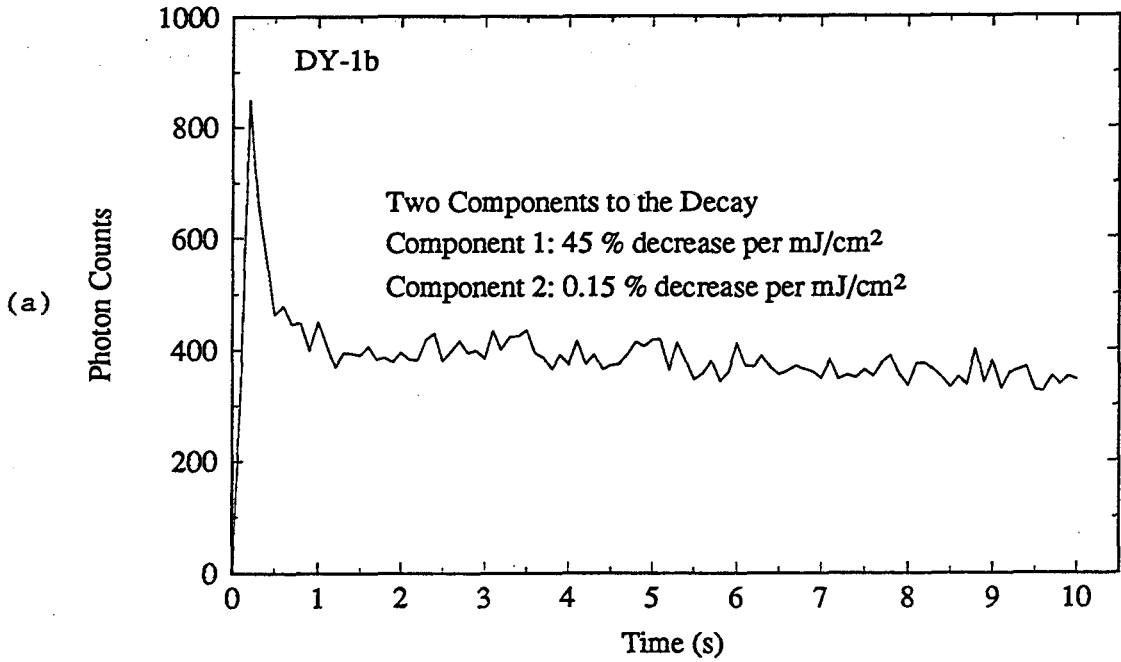

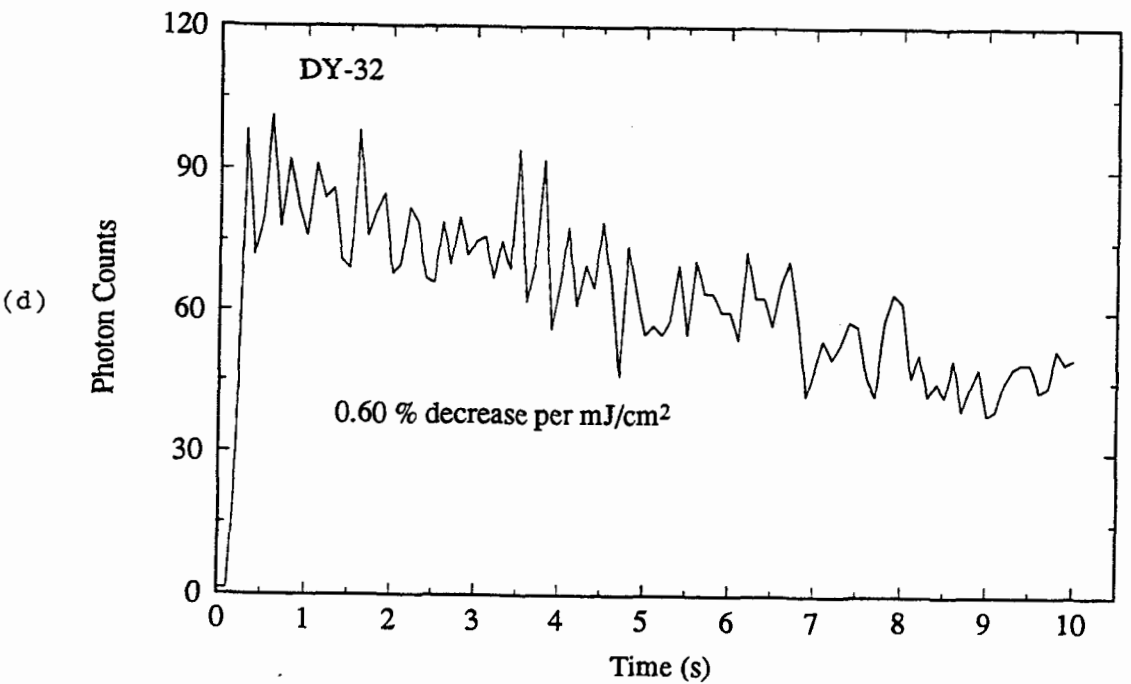
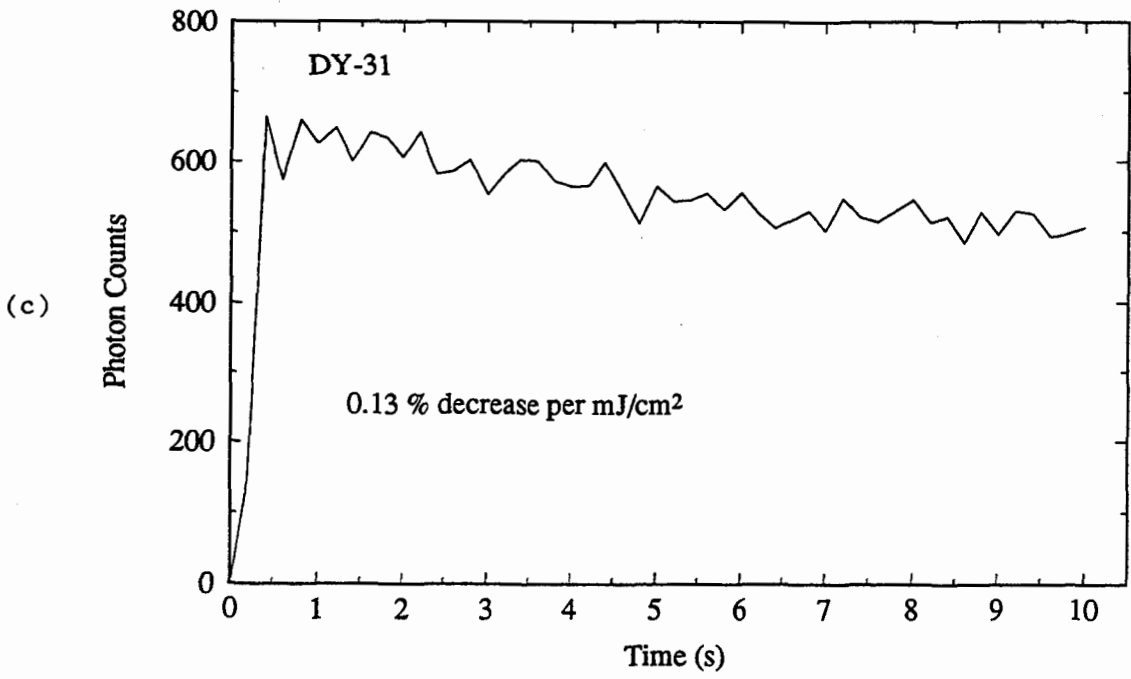

Figures 5.2a-d: 2.4 eV excitation shine-down curves from DY-1b (a), DY-1c (b), DY-31 (c) and DY-32 (d). The curves show the photon counts recorded for the first 10 s after the samples were exposed to the Ar laser. The sample sizes and grains sizes were as follows: DY-1b; 10 mg, unsieved; DY-1c; 8 mg, 90-150 μm ; DY-31; 10 mg, 250-425 μm ; DY-32 10 mg, 180-250 μm . The laser power on the samples was 11 mW/cm^2 , 7 mW/cm^2 , 14 mW/cm^2 , and 11 mW/cm^2 for DY-1b, DY-1c, DY-31, and DY-32 respectively. See Appendix A for measurement equipment details.

value for quartz is about 1% per mJ/cm^2 . Shine-down curves of quartz grains from various quartzites are presented in *Figures 5.2a-d*. There is a great deal of variation between these quartzites. DY-1c showed the usual 1% decrease, while DY-32 showed a 0.60% decrease. DY-31 had a slow 0.13% decrease, while DY-1b was very unusual, with a very fast component, 45%, followed by a slow component of 0.15%.

5.1.3 Responses to 1.4 eV (IR Diode) Excitation

Quartz grains extracted from DY-1b, DY-1c, DY-1d, DY-8, DY-9, DY-25, DY-26, DY-31, and DY-32 were each stimulated in turn by 1.4 eV excitation. Only DY-1c, DY-8 and DY-32 yielded measurable responses; shine-down curves are shown in *Figures 5.3a-c*. The emission spectrum of DY-1c is shown in *Appendix C*.

DY-1c and DY-32 show decays that are similar to other feldspar decays, while DY-8 shows a much slower decay.

5.2 Effect of Sun Bleaching

To understand the response to sun bleaching Godfrey-Smith et al's (1988) experiment was used as a model for a similar experiment using grains extracted from DY-1c (stratum 2) quartzite.

150-180 μm grains from HF layers 8-11 were combined, and 30 10 mg disks were prepared. Each disk was then exposed to the Ar laser for 3 seconds (laser power was approximately $15 \text{ mW}/\text{cm}^2$ on the sample) and the photon counts recorded and summed. The individual sums were divided by the average sum to produce a set of normalization values for later use to correct for the intrinsic variability of the disks.

Disks were exposed to sunlight for various lengths of time; 1 s, 10 s,

(a)

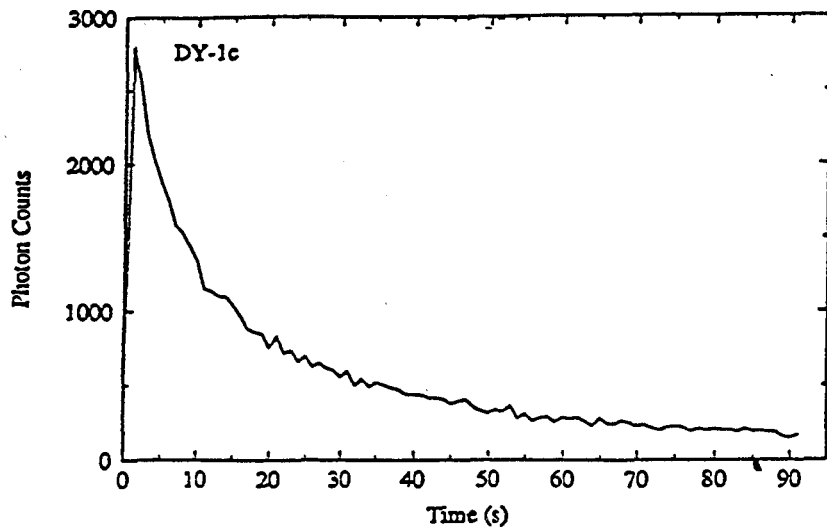

(b)

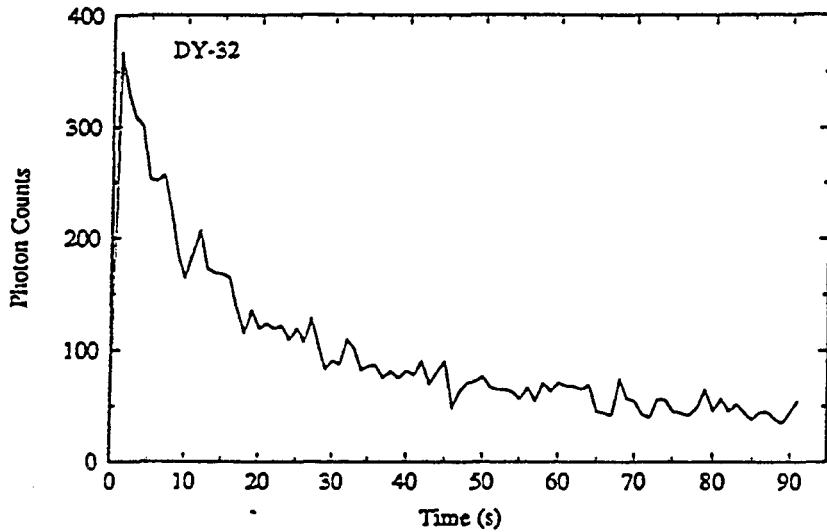

(c)

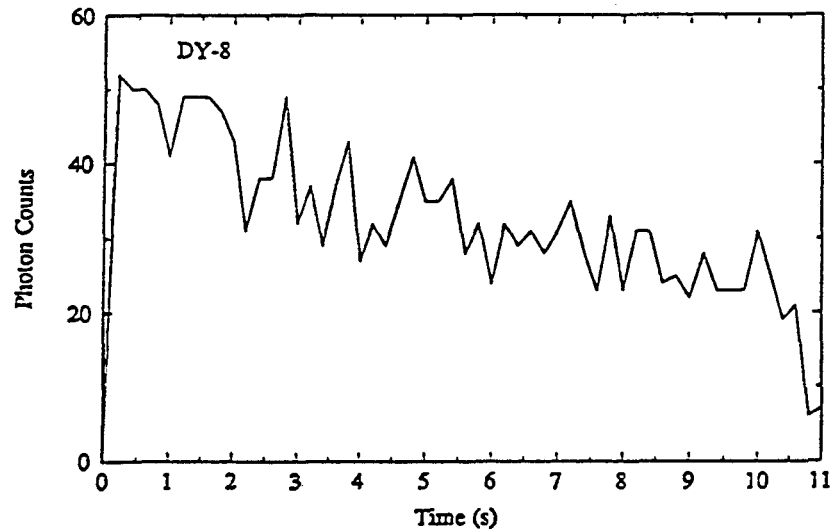

Figures 5.3a-c: 1.4 eV excitation shine-down curves from DY-1c (a), DY-32 (b), and DY-8 (c). DY-1c and DY-32 show similar rates of decay, while DY-8 is much slower. The IR diode power was about 40-50 mW/cm^2 on the samples. The sample sizes and grain sizes were as follows: DY-1c; 11 mg, 150-180 μm ; DY-32; 10mg, 106-180 μm ; DY-8; 1 mg, 250-425 μm . See Appendix A for measurement equipment details.

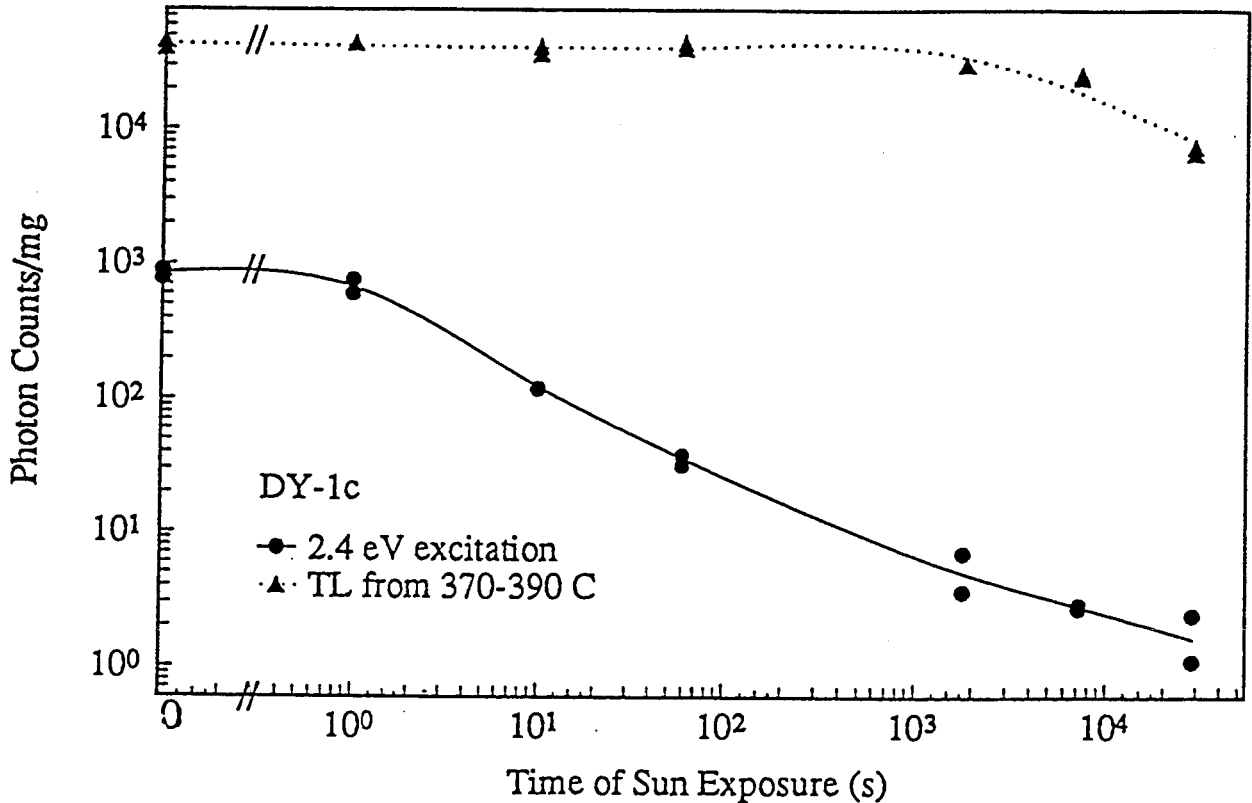

Figure 5.4: The effect of sunlight exposure on the optically excited luminescence and thermoluminescence of DY-1c quartz. 10 mg aliquots of 150-180 μm quartz from HF layers 8-11 were exposed to sunlight for various lengths of time, and were then measured using either TL or 2.4 eV excitation. The TL points are the sum of photon counts between 370 $^{\circ}\text{C}$ and 390 $^{\circ}\text{C}$ normalized by aliquot mass. The 2.4 eV excitation points are the normalized sums of the photon counts for the first second after the laser was turned on. The TL heating rate was 5 $^{\circ}\text{C}/\text{s}$ up to 500 $^{\circ}\text{C}$. The Ar laser power on the sample was 15 mW/cm^2 .

1 minute, 30 minutes, 2 hours and 8 hours, and then measured either for TL or with 2.4 eV (Ar laser) excitation. The resulting luminescence intensities were then normalized using the calculated normalization values, or, for the TL disks, their masses.

The light intensity (presented as the number of photon counts per mg) of each set of disks versus the length of sunlight bleaching is presented in *Figure 5.4*.

The TL values do not clearly show a decrease until the disks have been bleached in the sun for 8 hours, while the luminescence from the 2.4 eV excited samples decrease after 10 seconds of bleaching. Godfrey-Smith et al (1988:375) have similar results but they looked at the "well defined peak at 320-330 °C" for their quartz. The DY-1c quartz did not have a well defined peak in this region, so it is possible that different traps are being measured.

Godfrey-Smith et al (1988:375) observed that their Ar measured quartz grains had decreased to 1 % of their unbleached value after about 10 s, but the DY-1c quartz grains are reduced to 1 % after closer to 60 s. Stokes (1993:277-278) also carried out a similar experiment, and found that his quartz was reduced to 1 % of its natural Ar laser induced intensity after a "few minutes". Again, it is possible that different traps are being measured in all three cases.

The DY-1c results show that these extracted quartz grains do show bleaching, but there are differences from results reported by others working with sedimentary quartz.

6 Light Transmission and Sunlight Penetration Experiments

6.1 Light Transmission Experiments

To see how far, if at all, light penetrates into the quartzites, DY-1a and DY-1b were cut into slices of varying thicknesses. Then a He-Ne laser (red, 1.96 eV, 633 nm), with an output power of about 3 mW, was shone through the slices and the amount of light transmitted was measured by a light meter. The more specific experimental details are as follows.

The DY-1a quartzite was cut into slices with coarse, and then fine diamond saws. These slices were then mounted between two pieces of 5x5 cm black construction paper which had a one square centimetre hole cut into the middle. This was to allow light through only one square centimetre to reduce scattered light from the He-Ne laser. The samples were mounted on a stand which allowed the sample to be moved horizontally and vertically. The light transmitted through the slices was measured with a light detector. Ten points, 5 vertical and 5 horizontal, each 1 mm apart, in a cross shape, were measured for each slice. Then these measurements were averaged to give a mean value for each slice thickness. The intensity decreases with thickness are presented in *Figure 6.1a*. The detector was moved to different distances from the sample in order to measure the two different components of the light passing through the sample; the direct transmitted beam, and the scattered light. The light measured by the detector when it was far away from the sample is mostly the directly transmitted beam, while the light measured close to the sample will be both scattered and directly transmitted light.

The light transmission decreased to 8 % with a 0.6 mm slice, and was down to less than 3% with a 1.6 mm slice.

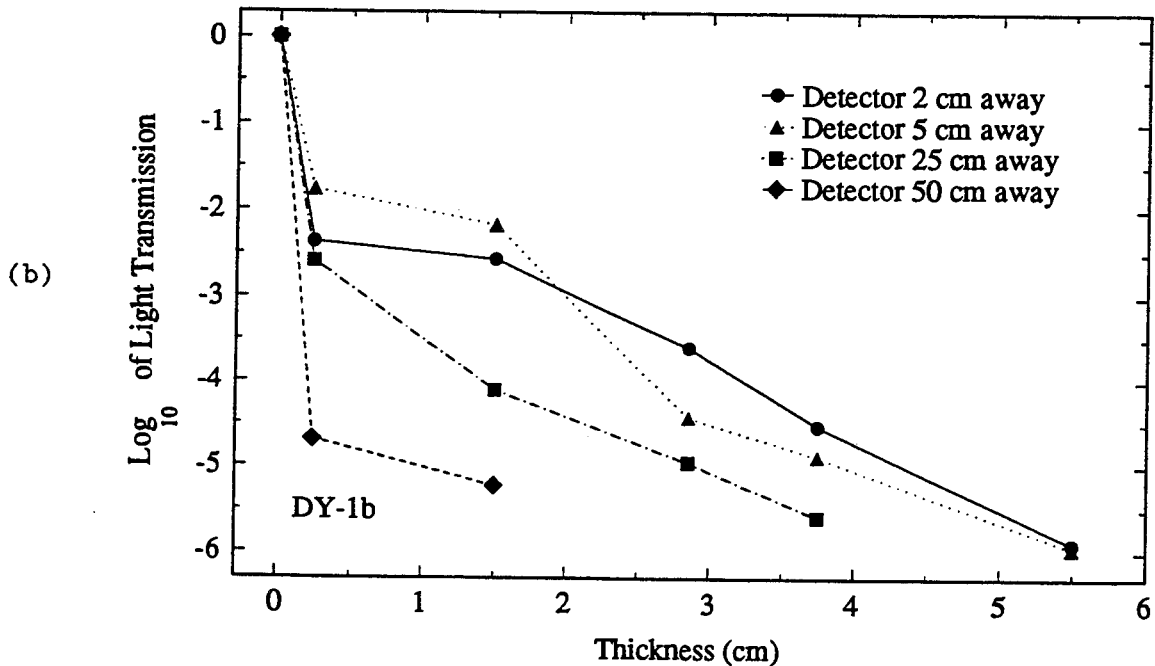
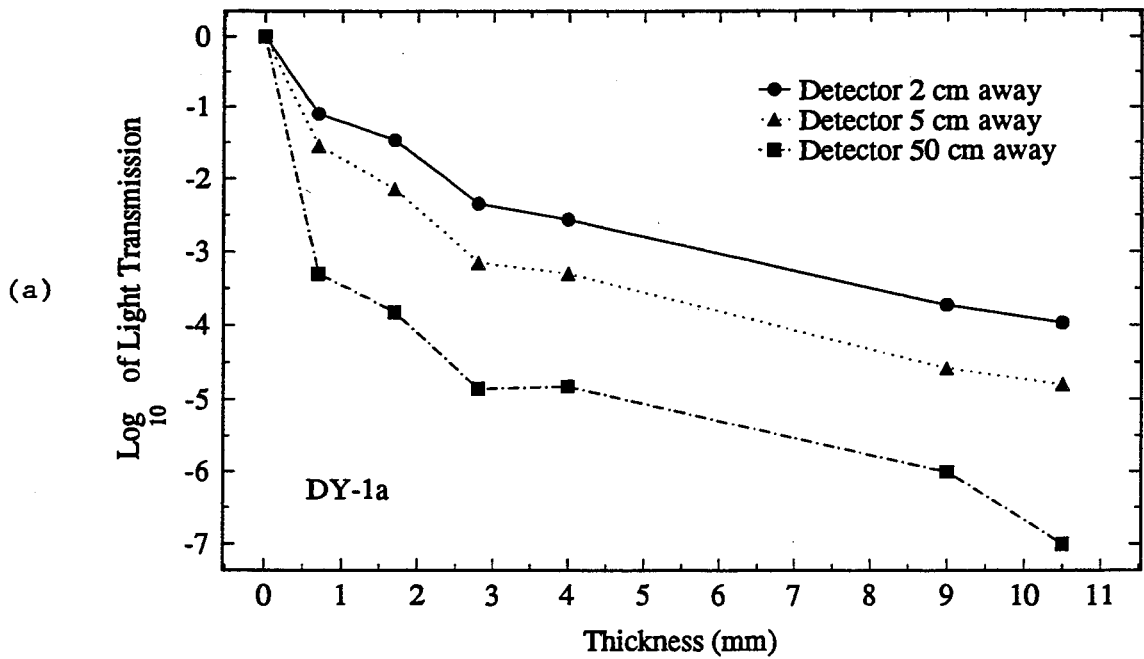

Figure 6.1a,b: The light transmission of slices of various thicknesses of DY-1a (a) and DY-1b (b). A HeNe laser was shone through the slices and the light transmitted was recorded. The light transmission is the amount of light detected divided by the amount of light detected if no sample were present.

The same experimental procedure as for DY-1a was followed with the DY-1b sample, and the results are presented in *Figure 6.1b*. DY-1b did not transmit the laser light as effectively as DY-1a. The light transmission had decreased to less than 1% with a 0.25 mm slice.

It seems then that a measurable amount of light is transmitted through several mm's of this quartzite.

6.2 Sunlight Exposure of Quartz Grains Within the Quartzite

One layer of grains was taken from one side of DY-1c. Then the other side of the rock was exposed to sunlight for 8 hours, and 11 HF layers were taken off that side.

The TL of 150-180 μm quartz grains prepared from each HF layer are shown in *Figure 6.2*. All of the glow curves are similar except for that of quartz from the outermost layer. These results are consistent with the results of the experiments presented above. The bleaching experiment presented in *Section 5.2* showed that the 380 °C TL peak did not decrease in intensity until the quartz was bleached for 8 hours. The light transmission experiments for DY-1b showed that the light transmission decreased to less than 1 % through a 0.25 mm slice. The HF experiments for DY-32 (*Section 4.4*) showed that each HF treatment removed about 0.25 mm of thickness from the outer quartzite layers. If the DY-1c quartzite behaves similarly to DY-1b and DY-32 then the sunlight intensity would have been reduced to 2 % after passing through the first 0.25 mm of DY-1b. An 8 hour sunlight exposure could only have affected the 380 °C TL peak of the quartz grains in the outer layer (first 0.25 mm) of DY-1c.

A similar set of disks were measured with 2.4 eV excitation. *Figure 6.3* shows the shine-down curves for the disks from each HF layer. The

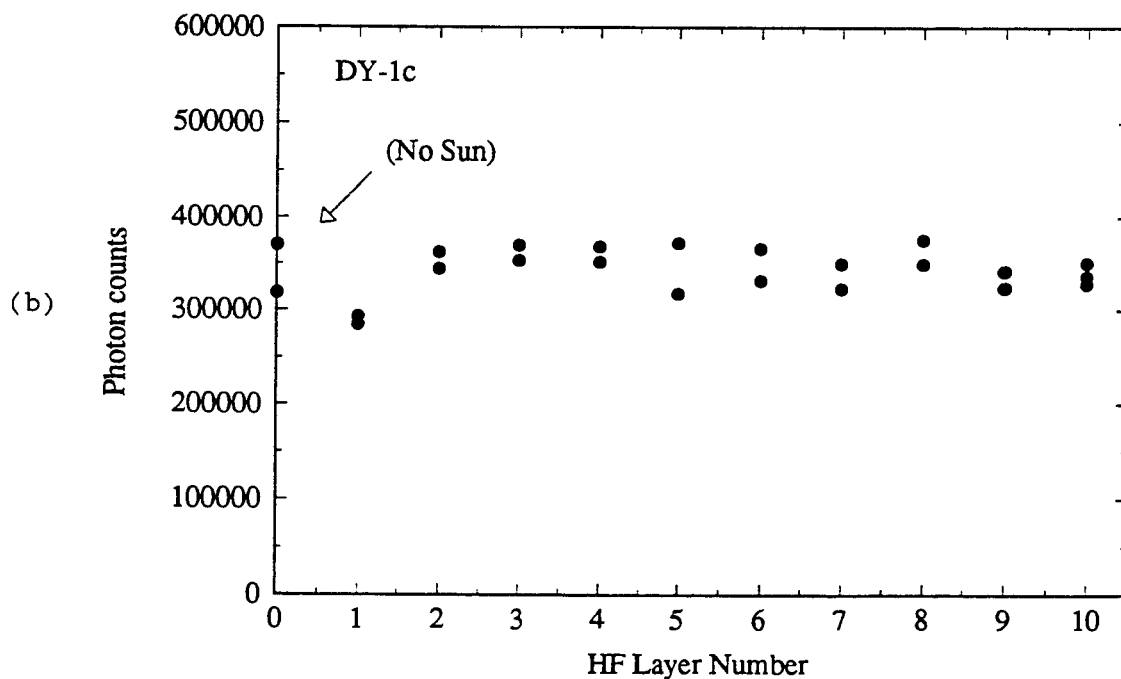
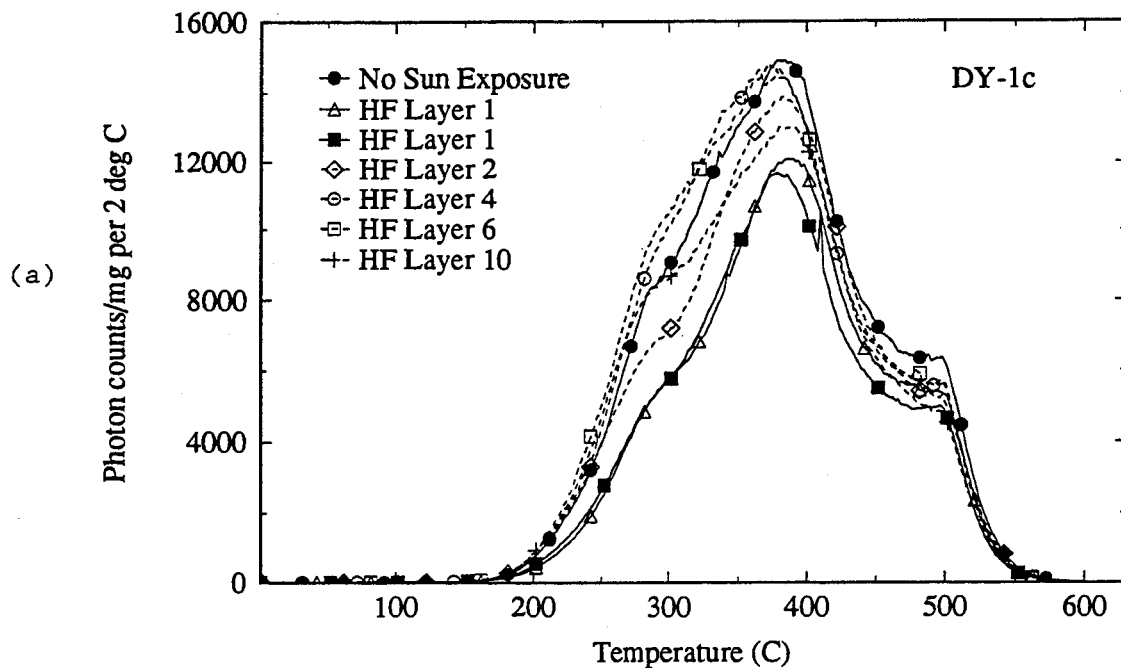

Figure 6.2a,b: The TL glow curves of 6 mg 150-180 μm aliquots from various HF layers of DY-1c (a), and the sum of photon counts from 350 $^{\circ}\text{C}$ to 400 $^{\circ}\text{C}$ from those glow curves (b). The DY-1c quartzite pebble was exposed to sunlight for 8 hours before the HF layers were removed. The TL heating rate was 5 $^{\circ}\text{C}/\text{s}$ up to 500 $^{\circ}\text{C}$. The values were mass normalized.

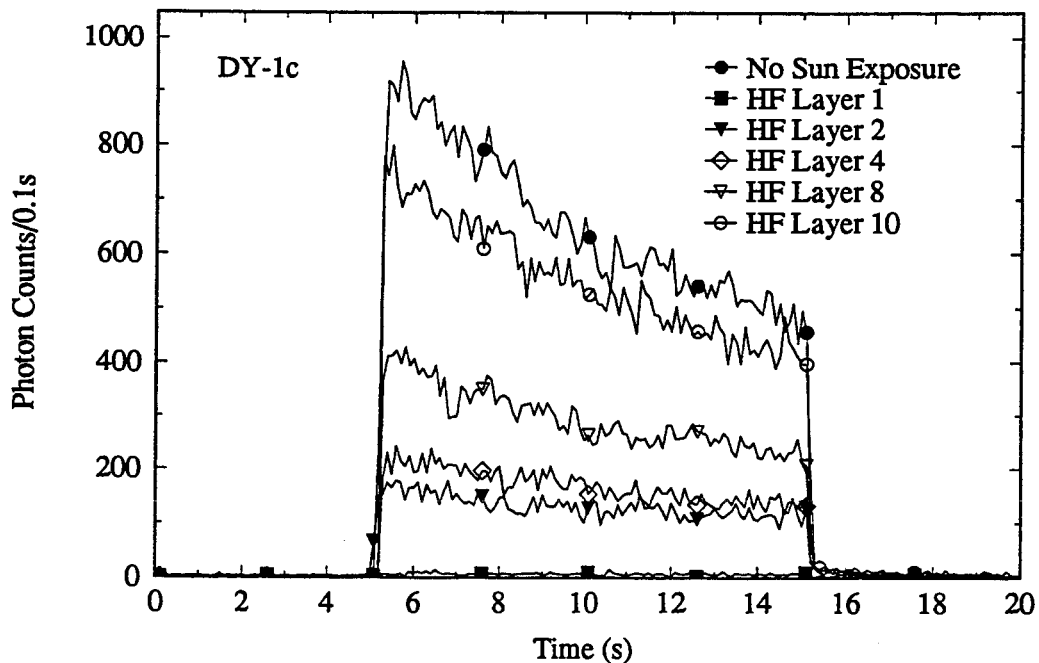

Figure 6.3: 2.4 eV excitation shine-down curves of 6 mg 150-180 μm aliquots from various HF layers of DY-1c. The DY-1c quartzite pebble was exposed to sunlight for 8 hours before the HF layers were removed. The Ar laser power was 7 mW/cm^2 on the sample.

intensity of the response was found to increase with depth of HF layer, starting at close to zero for the first layer. This is another demonstration of the superiority of optical excitation over TL to detect preferentially light-sensitive traps.

The experiment was repeated on another stratum 2 rock in order to obtain more definitive results. A small portion of DY-1d was removed with a 30 min HF treatment in the lab, and the rock put out into direct sunlight for 12.5 hours, and under overcast conditions for 5.5 hours. 7 HF layers were then taken off the rock. Some of the resultant 2.4 eV excitation shine-down curves are presented in *Figure 6.4a*. The sums of the photon counts for the first 10 s after the sample was exposed to the laser are shown in *Figure 6.4b*. It is apparent the sunlight does penetrate the quartzite, but its effect decreases with depth. After layer 6 (approximately 1.5 mm into the rock) this sun exposure had no effect. It is important to note that layer 1 had not decreased in intensity to the same level as grains that were bleached with a sunlamp for 24 hours.

These results are consistent with the results presented in *Section 6.1*, which show that He-Ne laser light penetrates into a sample. These results also showed that the HF treatments were a viable way of removing discrete and extremely thin layers of quartz grains from the quartzites.

6.2.1 DY-44 Sunlight Penetration

The experiment was repeated on a stratum 5 quartzite (DY-44) that had been uncovered and left on the surface by the archaeologists in 1991, a year before it was collected by D.J. Huntley. It was hoped the upper side of the rock had been exposed to sunlight for about 1 year, and the bottom side had not been disturbed and exposed to sunlight.

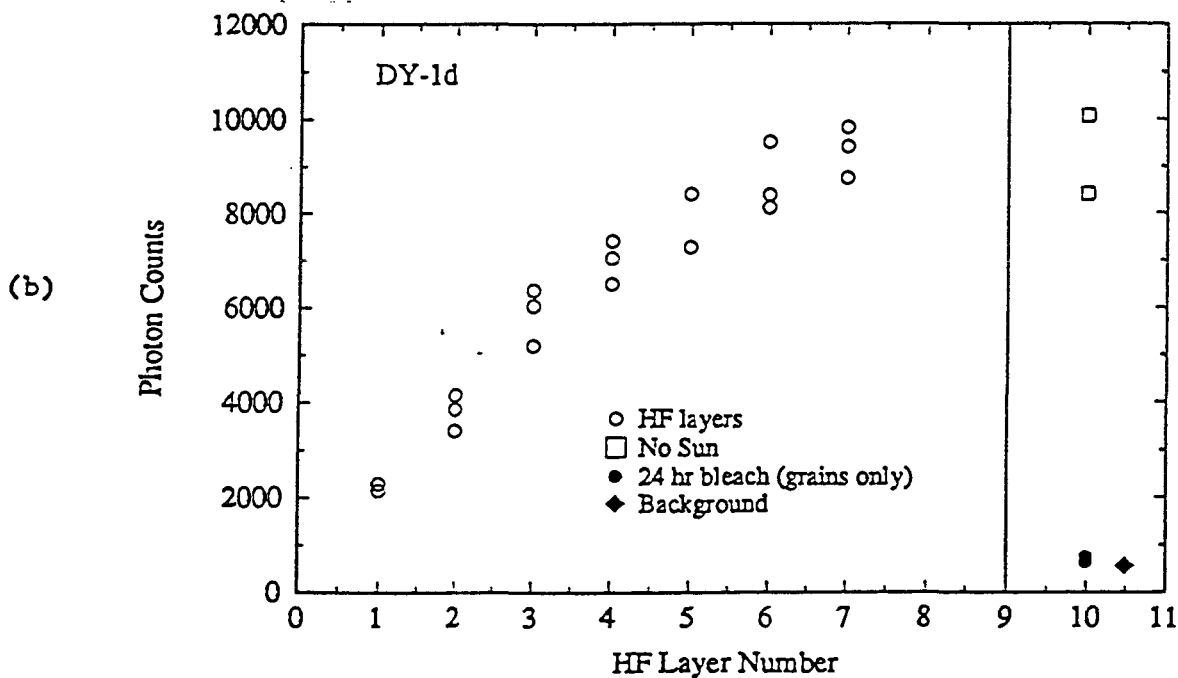
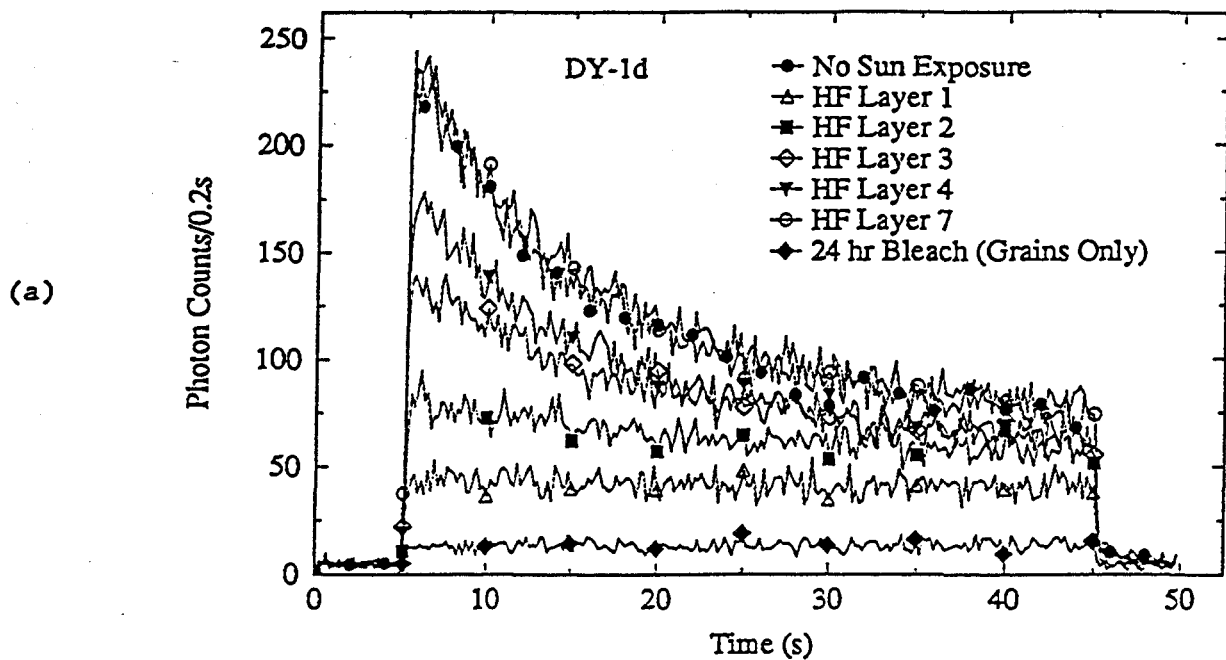

Figure 6.4a,b: Some of the 2.4 eV excitation shine-down curves of 10 mg 90-150 μm aliquots from various HF layers of DY-1d (a), and the sum of photon counts for the first 10 s after samples were exposed to the Ar laser (b). The DY-1d quartzite pebble was exposed to direct sunlight for 12.5 hours and under cloudy conditions for 5.5 hours before the HF layers were removed. The "no sun" points are from grains removed before the quartzite pebble was exposed to sunlight. The "24 hr bleach (grains only)" samples are from grains exposed to a sunlamp for 24 hours. The Ar laser power was 22 mW/cm^2 on the sample.

10 HF layers were taken off the "top", the side that had been exposed to the sunlight, and 5 layers were taken from the other side, the "bottom". *Figure 6.5* shows the sum of photon counts for the first 10 s of laser exposure for each disk plotted against the HF layer number. As can be seen the top had a very low intensity for the first 8 layers, but showed an increase with the ninth and tenth layers. By contrast, the bottom disks all had an intensity that was higher than the top disks, and there was no evident change in intensity with depth. The interpretation of these results is that the 1 year sunlight exposure emptied all the traps as far as layer 8, while the bottom of the rock had not been exposed to sunlight since it was originally deposited.

6.2.2 DY-32 Sunlight Penetration

DY-32, a strata 2 quartzite, had 11 HF layers taken off. Quartz grains from this rock did respond to IR diode stimulation. *Figure 6.6* shows the sum of the photon counts for the first 20 s of 1.4 eV exposure. The intensities are all very similar, which is what is expected for a sample that is very old with traps in saturation.

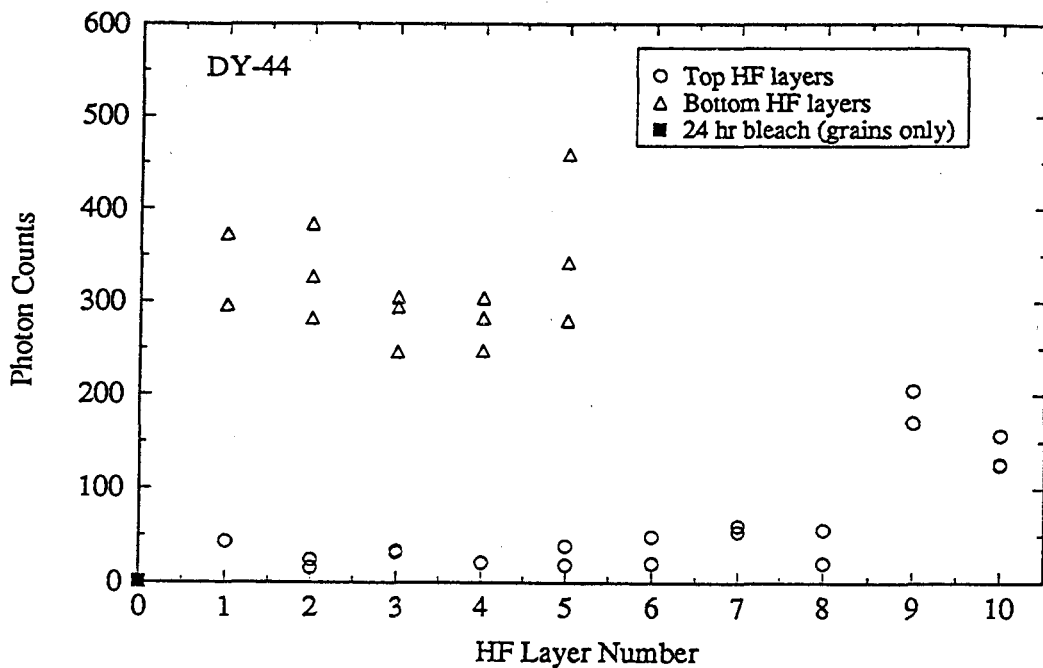

Figure 6.5: The photon counts from 90-180 μm 10 mg aliquots from different HF layers removed from the top and bottom of DY-44, using 2.4 eV stimulation. Each point is the sum of the photon counts for the first 10 s after the sample was exposed to the Ar laser. The "24 hr bleach (grains only)" samples are from grains exposed to a sunlamp for 24 hours. The background value (400 counts) was subtracted from each point. The laser power was 22 mW/cm^2 on the sample.

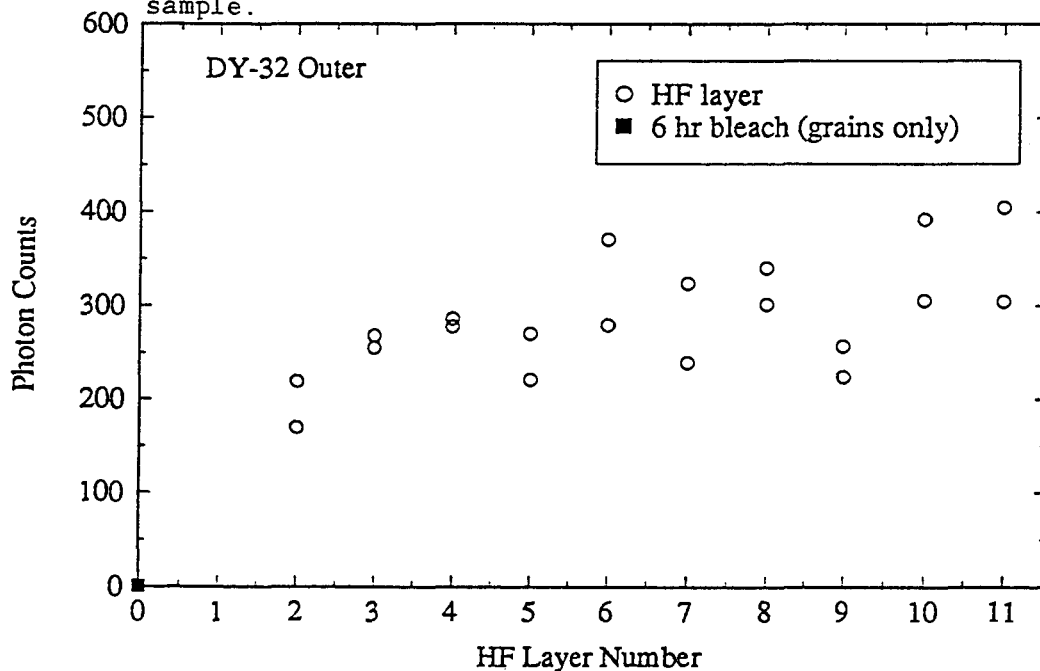

Figure 6.6: The photon counts from 180-250 μm 10 mg aliquots from different HF layers removed from the outer portion of DY-32, using 1.4 eV stimulation. Each point is the sum of the photon counts for the first 20 s after the sample was exposed to the IR diodes. The "6 hr bleach (grains only)" samples are from grains exposed to a lamp equipped with an RG-715 filter, which only passes infrared light. The background value (200 counts) was subtracted from each point. The IR diode power was about 15 mW/cm^2 on the sample.

7 Equivalent Dose Determinations

In this chapter are described the results of experiments designed to determine the equivalent dose (D_e) for two stratum 2 quartzites, DY-31 and DY-32, and one stratum 5 quartzite, DY-8. The experimental details will be reported first, along with any D_e 's determined, then the results will be discussed at the end of this chapter.

7.1. TL Equivalent Dose from DY-31 (Stratum 2)

6 HF layers were taken off the outer surfaces of both halves of this rock which had been broken in half during sample collection. Care was taken to ensure the HF did not come into contact with the broken surfaces to ensure the quartz grains were only from the outer layers. During HF treatment 1 and 5 the HF did touch the broken surface of one of the pieces for a few minutes, so although it is unlikely that any grains were removed during this short exposure HF layers 1 and 5 were not used for the D_e determinations. HF layers 2, 3, 4, and 6 were combined together, and 36 6-7 mg disks of 150-250 μm quartz were prepared, bleached and irradiated as was appropriate for a TL regeneration experiment. Representative glow curves were presented in Figure 5.3. The photon counts at the 375 °C peak (data between 350 °C and 400 °C), divided by their mass, are shown plotted against the laboratory dose in Figure 7.1a,b.

Comparison of the intensity of the unirradiated (N) disks to the regeneration growth curve indicates that it would take about 100 Gy of laboratory irradiation to make a bleached sample emit as much light as the natural samples. The N+dose growth curve has a similar shape to the

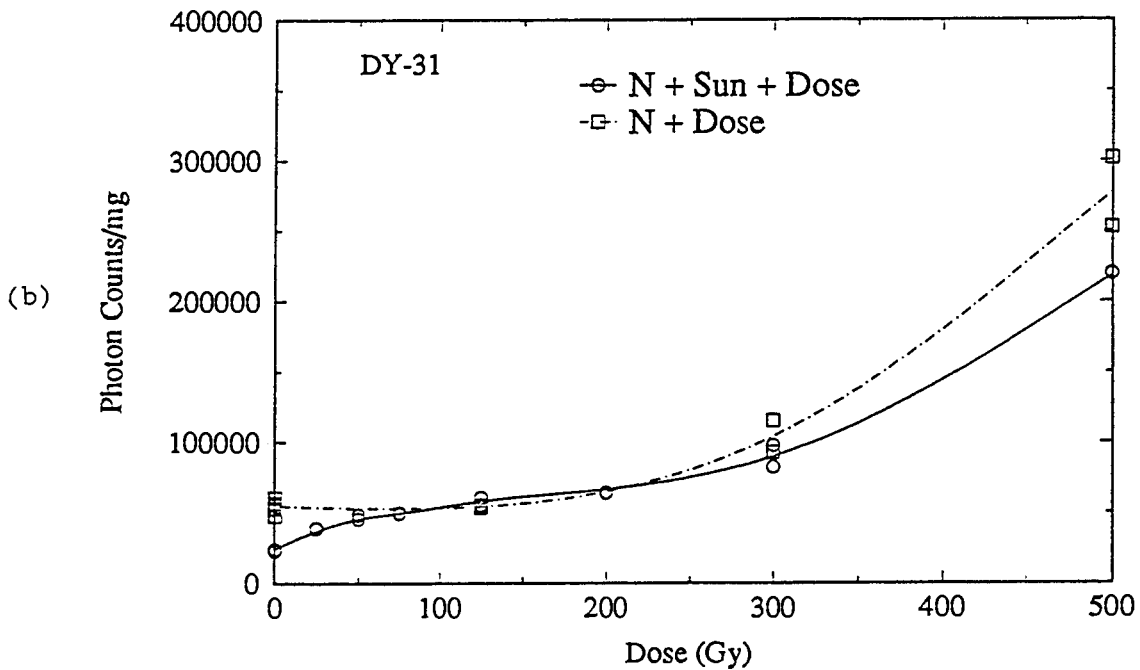
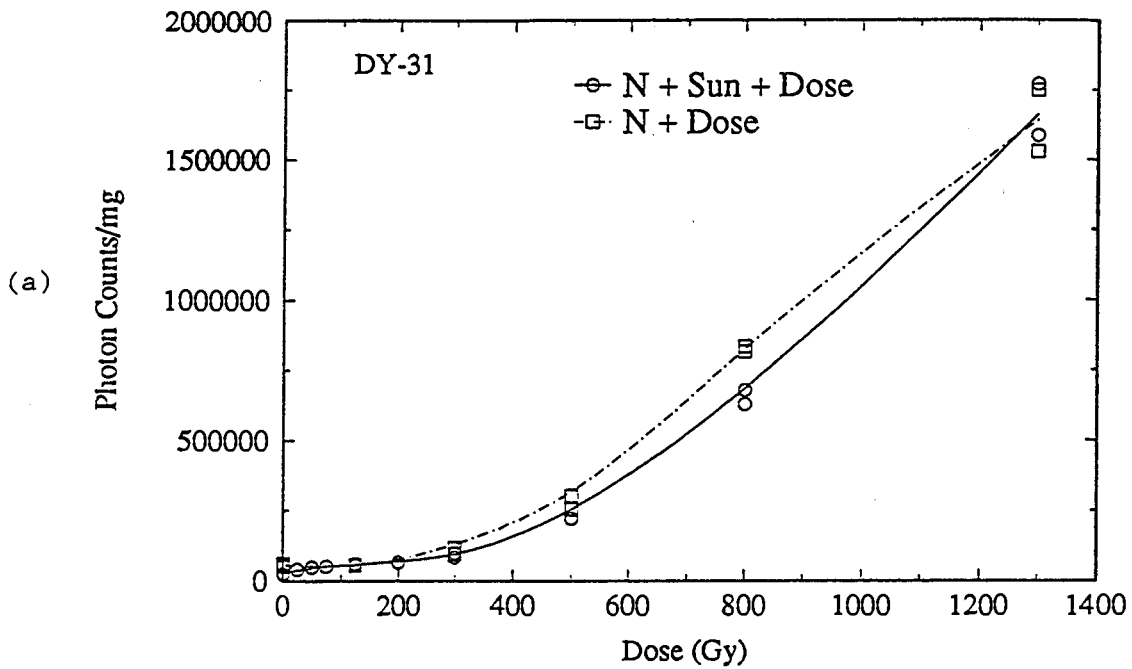

Figure 7.1a,b: The DY-31 TL regeneration experiment. Each point is the sum of the photon counts from 350 °C to 400 °C of 6.5 mg 150-250 μm quartz grain aliquots from HF layers 2,3,4 and 6; each point was mass normalized. The "N + Sun + Dose" samples were bleached in the sunlight for 20 hours. The heating rate was 5 °C/s.

regeneration growth curve, so it does not seem that the sample has changed sensitivity due to the bleaching. However, one can see two components to the curves. There is a rise in intensity until a saturation at about 100 Gy which represents trap filling. Then there is an increase at higher doses that is often observed (D.J. Huntley, personal communication) but is not understood. One cannot use these data for a D_e determination. The best one can conclude is that the deep traps in these quartz grains were in saturation, and it takes about a 100 Gy laboratory dose to saturate those traps.

7.2 DY-31 Ar Laser Experiments

Two regeneration experiments were then carried out using 2.4 eV stimulation. The first experiment was unsuccessful because there was a great deal of scatter in the data, and the second failed because there was not much light intensity from the samples, and each sample had a similar amount of luminescence, despite its treatment.

7.3 1.4 eV (IR Diode) Excitation of DY-32 (Stratum 2)

Before an equivalent dose determination was attempted an experiment was undertaken to obtain guidance in the appropriate preheat to be used. This was done by subjecting untreated samples ("naturals") to a variety of temperatures for 4 hours. Data for samples that had been bleached, and bleached then irradiated with 500 Gy of gamma radiation were also obtained. 47 10 mg disks were prepared using 250-425 μm quartz grains from HF layers 1-11 for the experiments. Figure 7.2 shows the sums of the first 20s of data after the diodes were switched on for each disk, plotted against the preheat temperature.

The optimum preheat would minimally empty the deeper traps that are

filled in the natural sample (thermally stable traps) and completely empty the shallow traps filled by the laboratory irradiation (thermally unstable traps). For a preheat that reduces the intensity of untreated samples by half, in this case 4 hours at 160 °C, it is very likely that any thermally unstable traps filled by the laboratory dose would be emptied by the same preheat.

The relationship between the N and N+bleach+dose samples should change as the preheat temperature is increased. Without any preheats, the N+bleach+dose disks should give off more light than the N disks. This is because shallow traps that are empty in the N disks will be filled in the N+bleach+dose disks due to the laboratory irradiation. One expects the intensity ratio to get smaller as the shallow traps are emptied in the N+bleach+dose disks, until this ratio becomes constant. At this plateau level the shallow traps in the N+bleach+dose disks will have been emptied. Any intensity difference will then be due to the number of filled deep traps in the two sets of samples. *Figure 7.3* shows this ratio for the DY-32 sample.

A 160 °C 4 hour preheat was thus considered the optimal preheat to use. Compared to the higher temperature preheats, 160 °C seemed to adequately empty the shallow traps while draining the least amount of the deeper traps.

A regeneration experiment was prepared using 106-180 μm quartz from HF layer 1-11 of DY-32, 10 mg per disk. The results are shown in *Figure 7.4*. The natural disks intercept the regeneration growth curve at around 500 Gy. Since the two data sets do not coincide after shifting, it was not possible to get a D_e from these data.

DY-32 was then cut with a diamond saw so that an approximately 2 cm by 1 cm block from the centre of the quartzite was produced. 15 HF layers were then taken off this inner portion of DY-32. Disks were each coated with about 10 mg of 250-425 μm quartz grains. About 2-3 disks were produced for

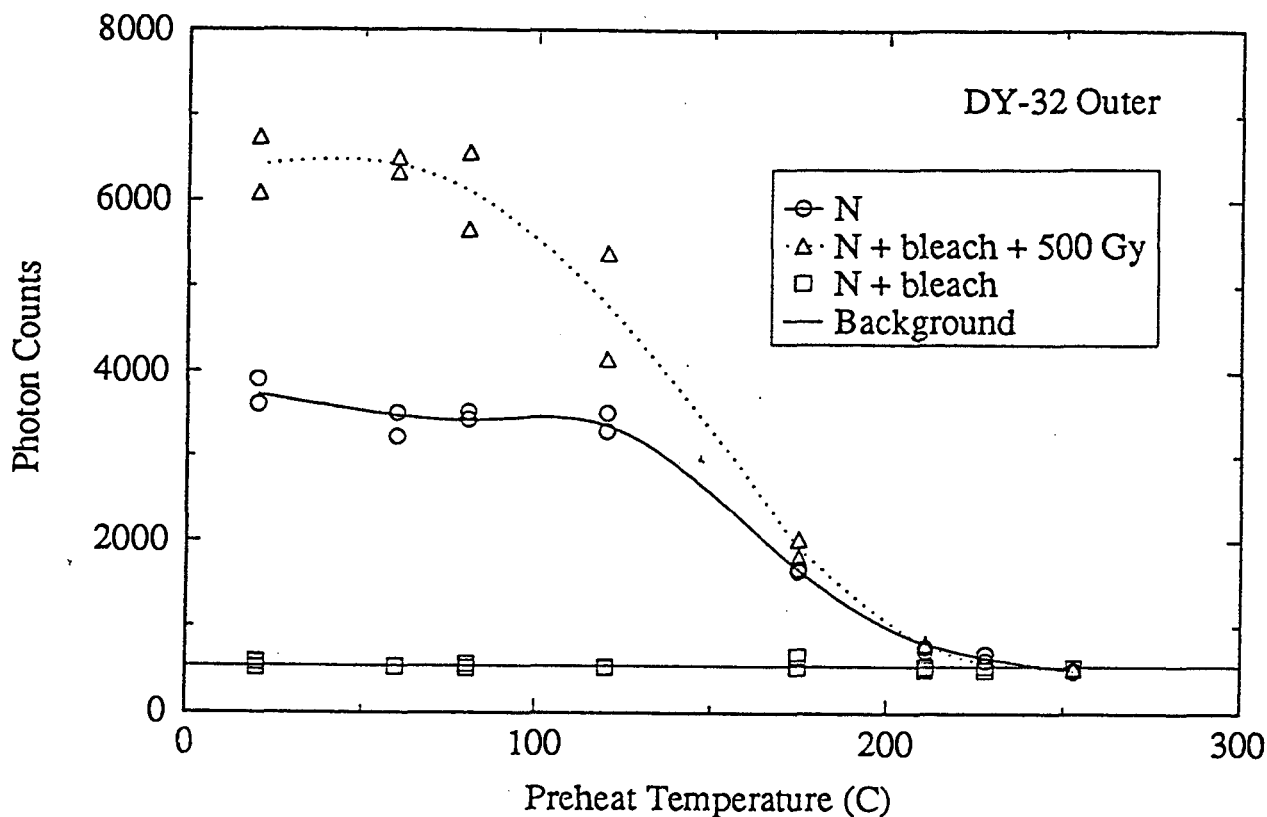

Figure 7.2: The effect of various preheats on DY-32 samples stimulated with 1.4 eV excitation. Each point is the sum of the photon counts for the first 20 s after the samples were exposed to the IR diodes. The aliquot size was 10 mg and the grain size was 250-425 μm . The "N + bleach + 500 Gy" and the "N + bleach" samples were bleached with a quartz halogen lamp equipped with an RG-715 filter for 3 hours. Each sample was normalized using a short-shine value measured before the aliquots were bleached and preheated. Each aliquot was heated for 4 hours at the given preheat temperature. The IR diode power during measurement was about 15 mW/cm^2 on the samples.

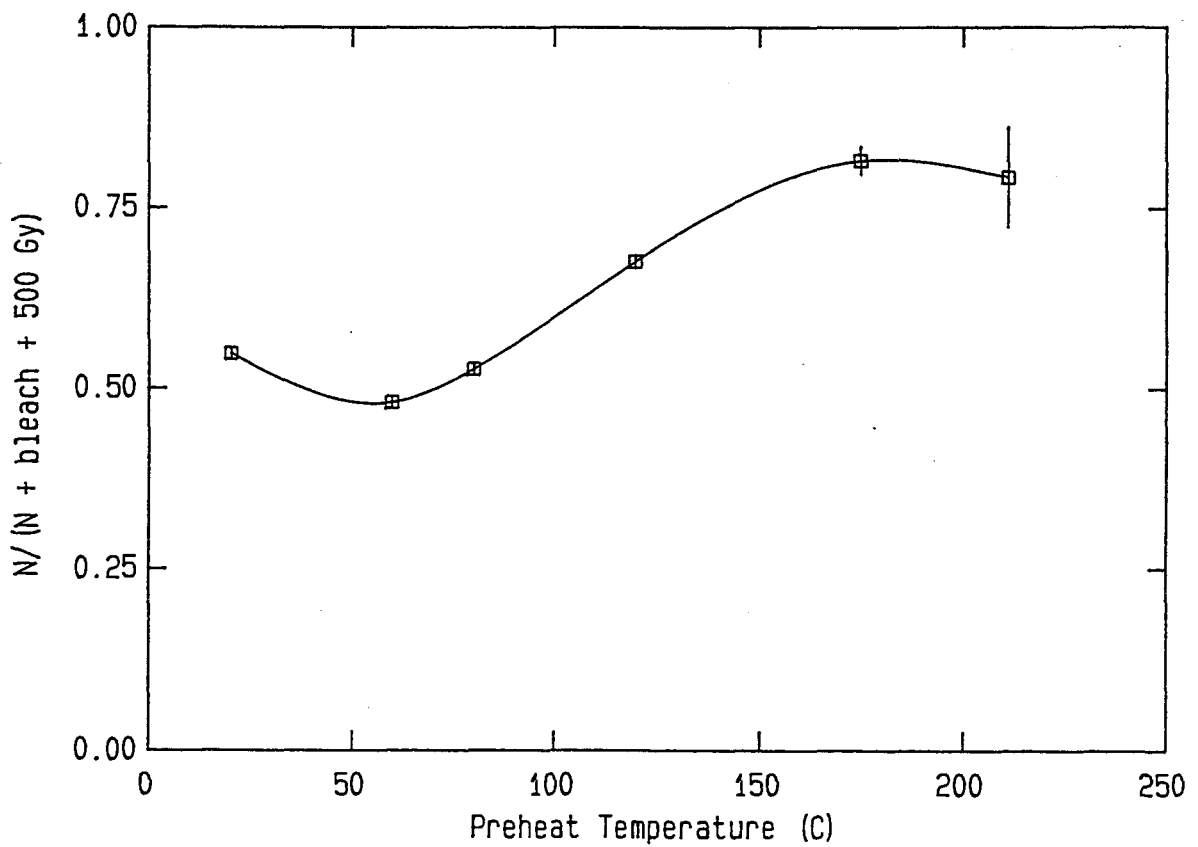

Figure 7.3: The ratio of the intensities of the N + bleach + 500 Gy and the N samples at each preheat temperature for DY-32, using 1.4 eV stimulation. The N + bleach values were subtracted from both first.

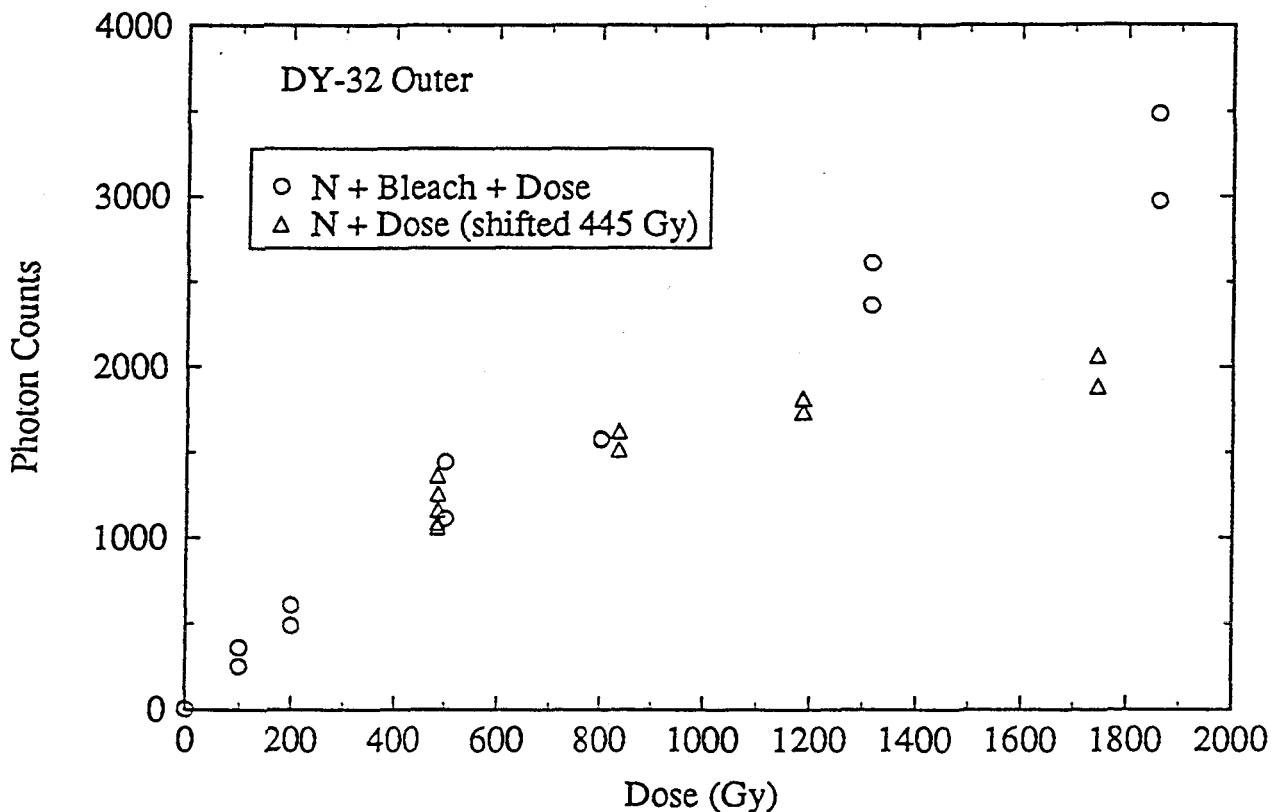

Figure 7.4: The DY-32, outer portion, 1.4 eV stimulation regeneration experiment. Each point is the sum of photon counts for the first 10 s after the samples were exposed to the IR diodes. Each point was normalized by a short-shine value measured before the aliquots were bleached and irradiated. The background value (30 counts/s) was subtracted from each point. The bleach was exposure to a quartz-halogen lamp equipped with an RG-715 filter for 3 hours. The samples were preheated at 160 °C for 4 hours before measurement. The IR diode power was about 15 mW/cm² on the samples.

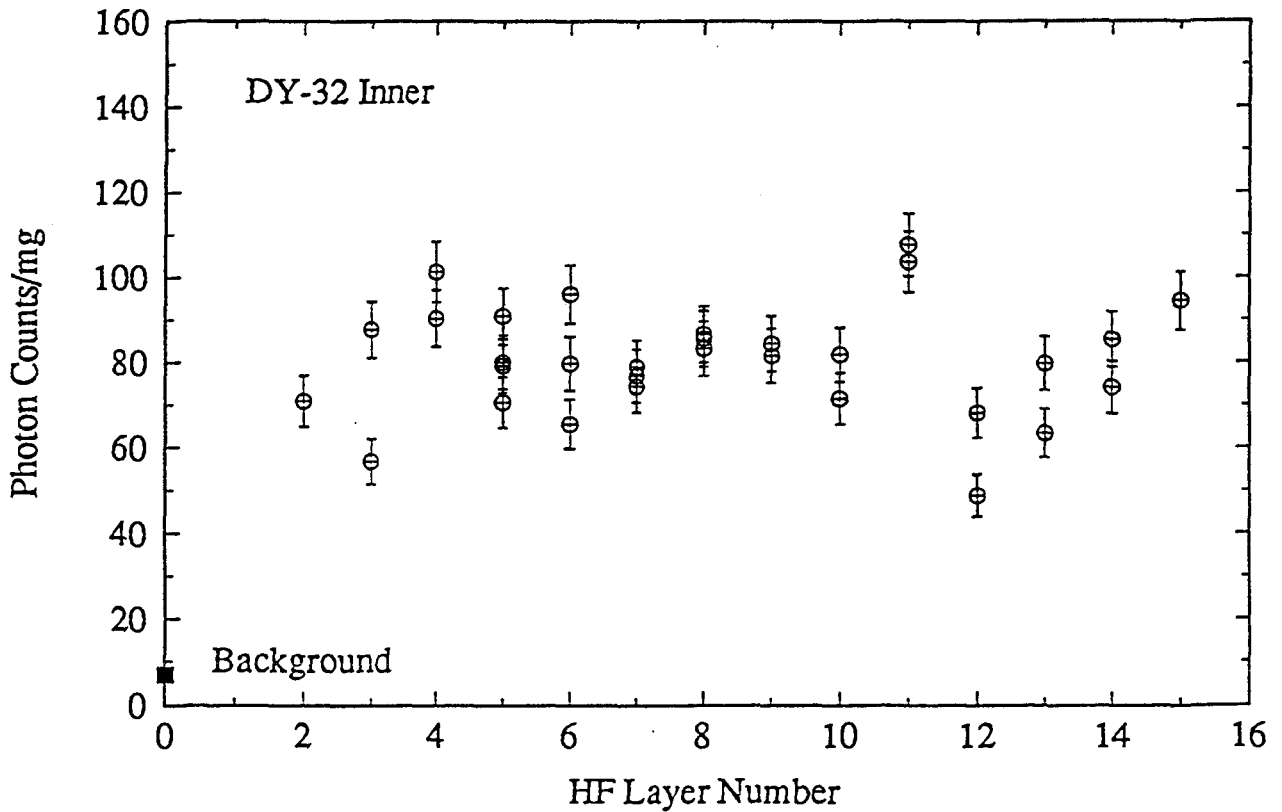

Figure 7.5: The intensities of 10 mg aliquots of 250-425 μm quartz grains from various HF layers taken from DY-32, inner portion, using 1.4 eV stimulation. Each point is the sum of photon counts for the first 5 s after the samples were exposed to the IR diodes, and each point was mass normalized. The IR diode power was about 15 mW/cm^2 on the samples. The error bars are $\pm \sigma$ calculated from counting statistics.

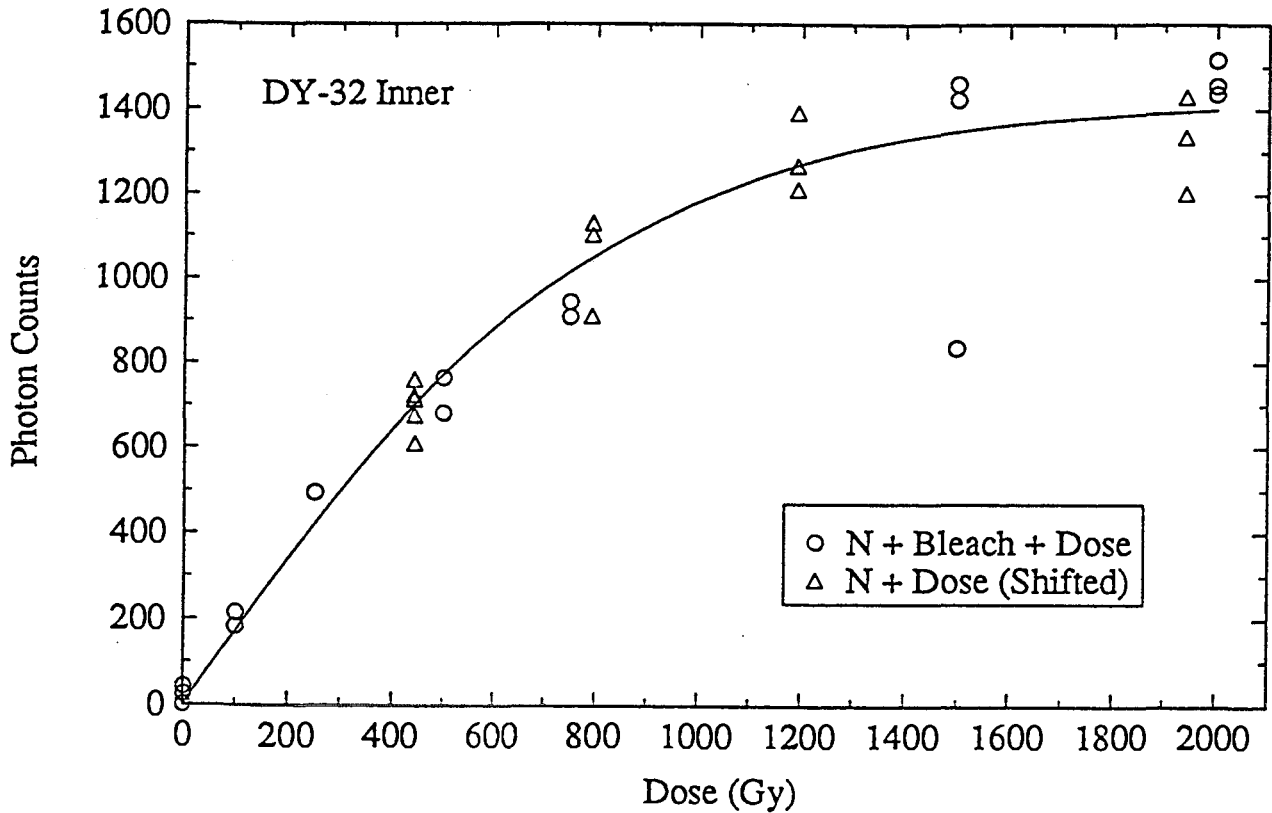

Figure 7.6: The DY-32, inner portion, 1.4 eV stimulation regeneration experiment. Each point is the sum of photon counts for the first 10 s after the samples were exposed to the IR diodes. Each point was normalized by a short-shine value measured before the aliquots were bleached and irradiated. The background value (20 counts/s) was subtracted for each point. The "N + Bleach + Dose" samples were exposed to a quartz-halogen lamp equipped with an RG-715 filter for 3 hours. The samples were preheated at 160 °C for 4 hours before measurement. The IR diode power was about 15 mW/cm² on the samples. The solid line is a maximum likelihood fit of a saturating exponential to both sets jointly, with the shift for the N+dose data being a parameter in the fit.

each HF layer. The intensities of disks from each HF layer were found to be very similar (see *Figure 7.5*) so it does not appear the sawing emptied any relevant traps.

These same disks were then used for a regeneration D_e determination, and the results are shown in *Figure 7.6*. The growth curves and results are similar to the first DY-32 outer results, except that here the higher dose regeneration data points are consistent with the rest of the data.

The average D_e of each of the 10 s interval's D_e 's was 440 ± 90 Gy. This value is similar to the dose-shift shown in *Figure 7.4*.

7.4 1.4 eV (IR Diode) Stimulation of DY-8 (Stratum 5)

After the above DY-32 results it was decided that a similar experimental procedure be applied to a stratum 5 quartzite to determine a D_e using the IR diodes. Quartz grains extracted from four stratum 5 rocks (DY-8, DY-9, DY-25, DY-26) were exposed to the IR diodes, but only one, DY-8, yielded a significant luminescence. Unfortunately, DY-8 was a comparatively small rock.

The first step in sample preparation was to extract quartz grains from the top and bottom of DY-8. 18 HF layers were taken from the top, and 15 were taken from the bottom, but due to the small size of the rock only about 5-10 mg of quartz grains were produced from each HF treatment. About 1-2 mg of quartz grains in the 250-425 μm size range were put on disks. About two disks were prepared for each HF layer. The disks were exposed to the IR diodes (40-50 mW/cm^2 on the sample) for 10 seconds. The photon counts for each disk for the 10 s of IR diode exposure was summed and normalized by sample mass. The results are shown in *Figure 7.7*. The data points are very scattered, and it was hard to discern any patterns in the data. It seems likely that there

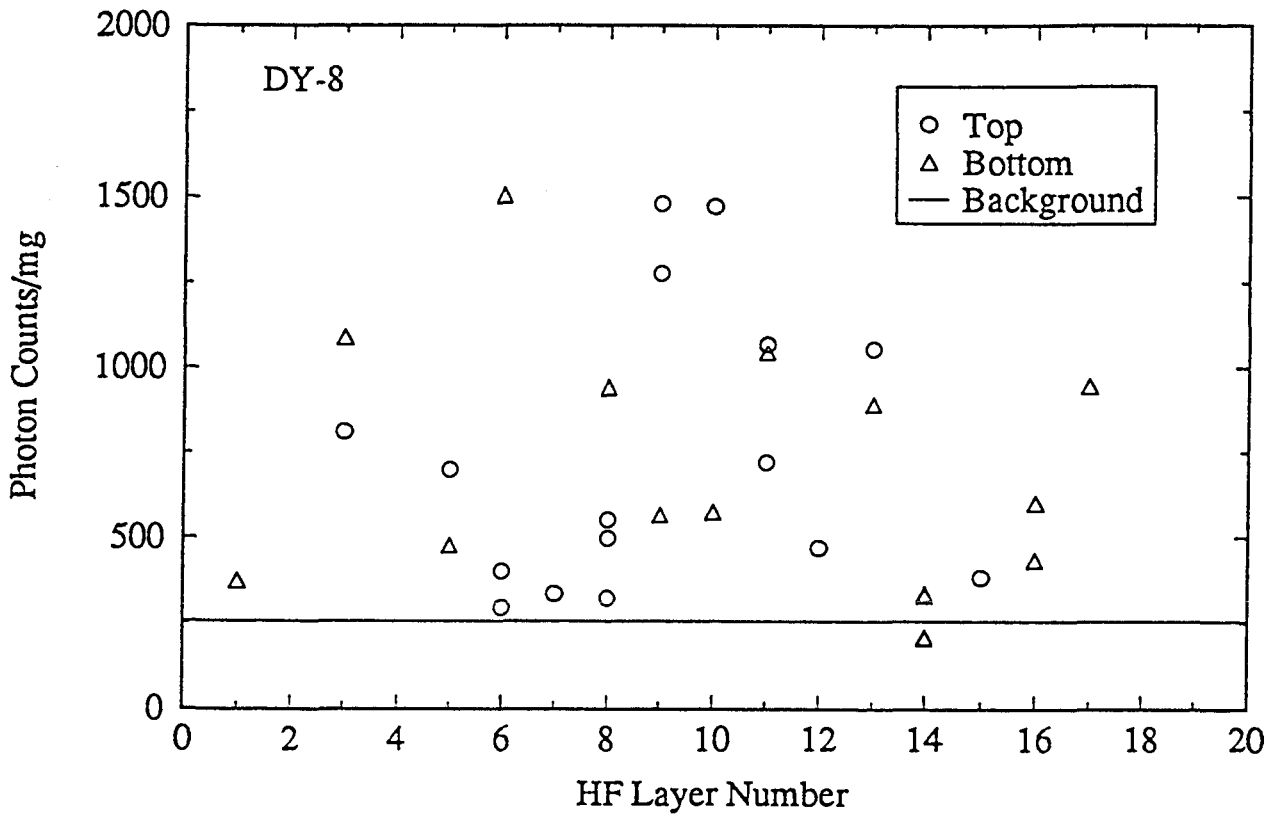

Figure 7.7: The intensity of 1.5 mg aliquots of 250-425 μm quartz grains from various HF layers taken from DY-8 top and bottom, using 1.4 eV stimulation. Each point is the sum of photon counts for the first 10 s after the samples were exposed to the IR diodes, and each point was mass normalized. The IR diode power was about 40-50 mW/cm^2 on the samples.

is no real difference between the top and bottom, nor any dependence on layer number.

The remaining grains from the top HF layers were combined, as were the bottom grains. In the 106-250 μm range there was only 7.5 mg of sample from the top and 13 mg from the bottom, not enough sample to carry out a regular regeneration determination, consequently the single aliquot technique was used. Two 3 mg disks were prepared from the quartz grains extracted from the top, and four 3 mg disks were prepared from the bottom. One of the latter was used as a control sample; it was measured and preheated along with the other disks but it was never irradiated or bleached. At each stage of the measurements the disks were measured with the IR diodes for 5 seconds at a diode power of about 15 mW/cm^2 on the sample. The preheats were 120°C for 16 hours, which was recommended as being gentle enough to avoid draining most of the deep traps while emptying the shallow traps (D.J. Huntley, personal communication). The intensity after the preheat was two thirds of what it was before.

The photon counts for each 5s IR diode exposure were summed and are shown in *Figures 7.8a-e*. The N+dose growth curve is nearly constant, which suggests the samples were in saturation. It was not possible to correct each point for the intensity loss due to the preheats because the growth curve was not expected to be linear, as it was in Duller's experiments (1991). This suggests that the preheats drained some of the saturated deep traps, but the next irradiation filled these traps up again. These same traps would then be emptied by the preheat and the process continued.

The regeneration data were used to estimate the dose at which the traps approach saturation. For all four disks, the regeneration growth curve approaches the N+dose growth curve value after an added dose of about 400 Gy.

(a)

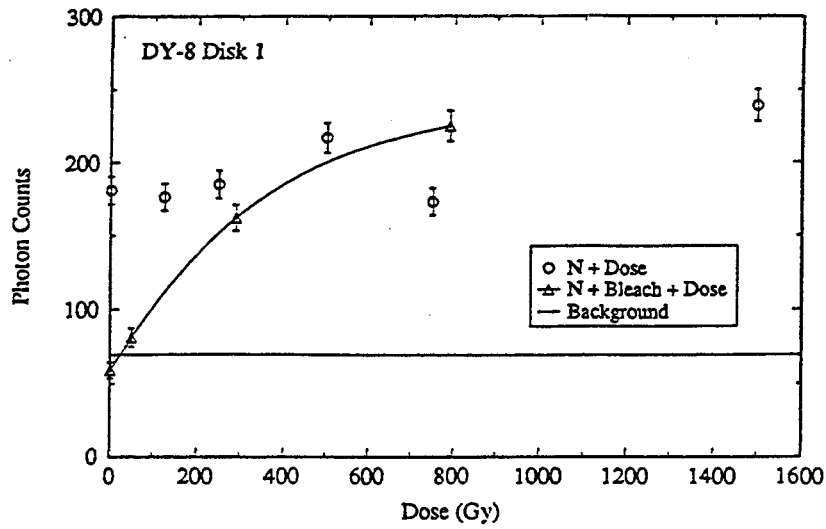

(b)

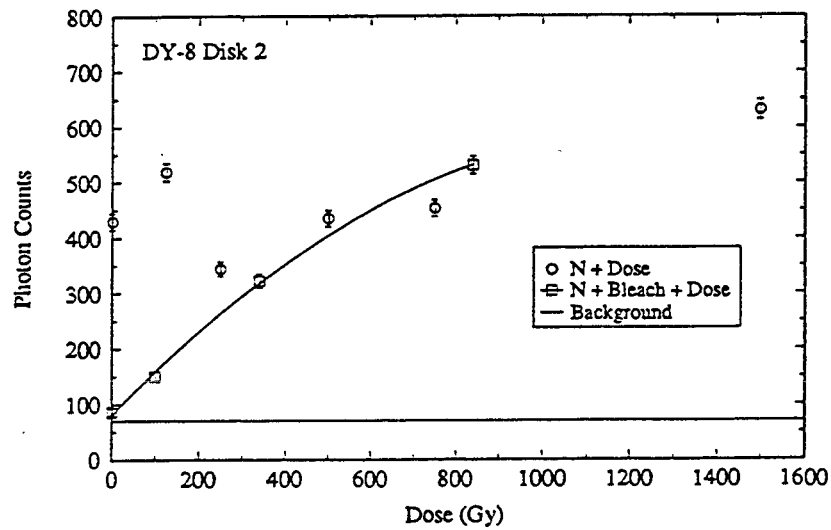

(c)

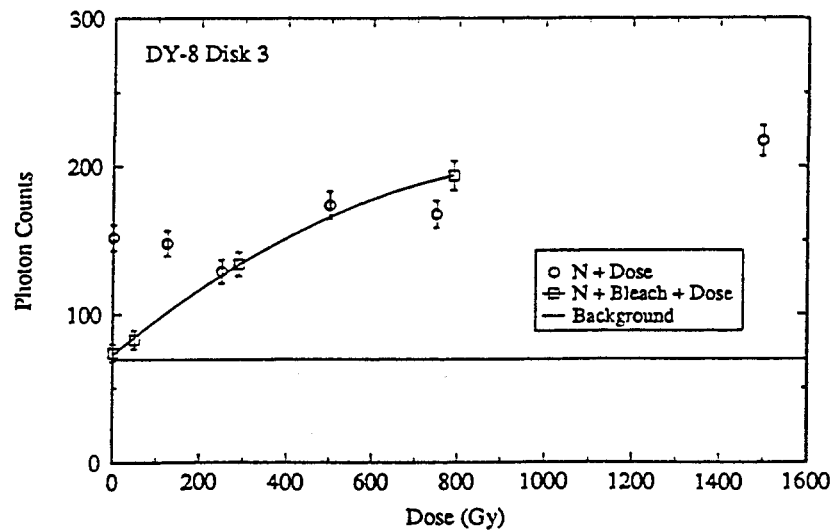

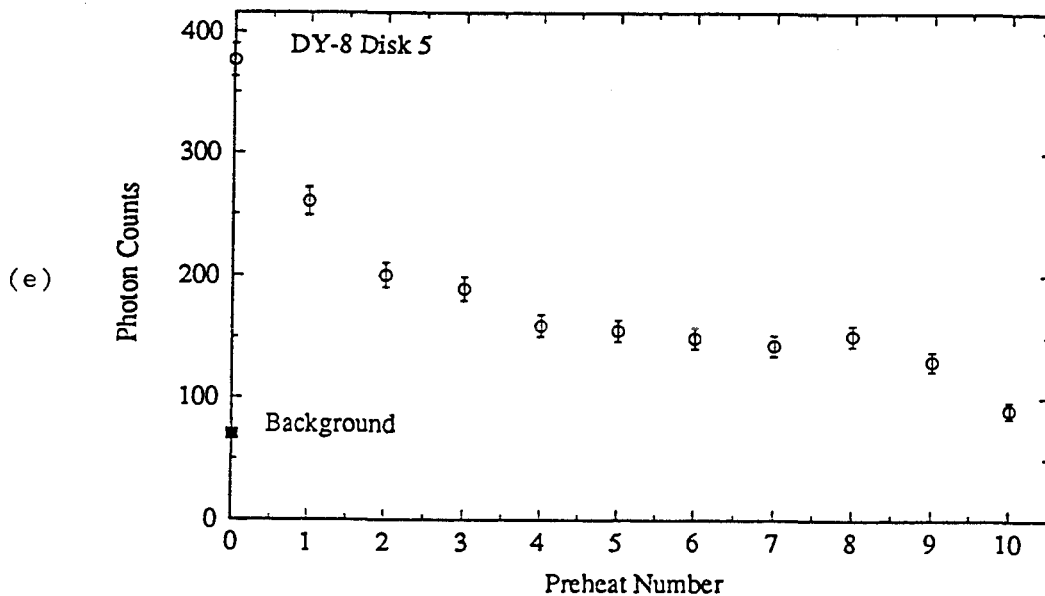
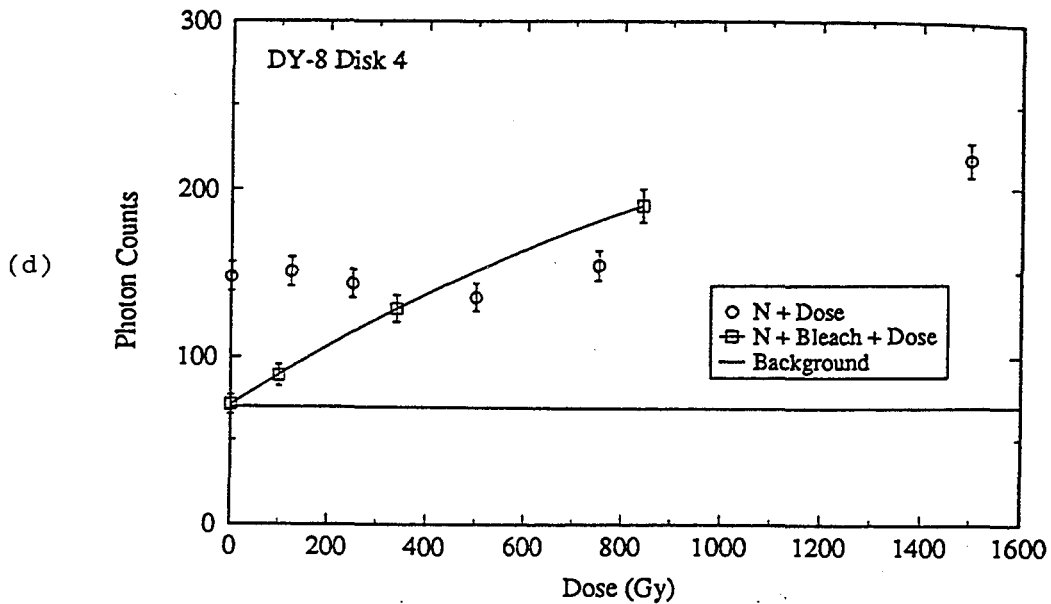

Figures 7.8a-e: The DY-8 single aliquot equivalent dose determination experiment. The sample size of each aliquot was 3 mg, and the grain size was 106-250 μm . Two samples used grains from the 18 HF layers taken from the top (disks 1 and 2), and three samples used grains from the 15 HF layers taken from the bottom (disks 3, 4 and 5); disks 1, 2, 3, 4, and 5 are shown in figures 7.8a-e respectively. Each data point is the sum of the photon counts for 5 s of IR diode exposure. The samples were preheated for 120 $^{\circ}\text{C}$ for 16 hours before each measurement. Disk 5 was preheated but never bleached or irradiated. IR diode power was about 15 mW/cm^2 on the samples. Error bars are the square roots of the numbers of counts.

However, the regeneration curve goes higher than the naturals. More data are needed in order to produce a workable model. However, using the above data, the lower limit for the D_e would be about 400 Gy.

7.5 Discussion

The stratum 2 samples were collected as control samples as they were considered to be very old; they should be in saturation. Any values less than saturation may indicate that the samples are anomalously fading, information which would be needed for the interpretation of stratum 5 results. However, each quartzite sample seemed to be different, which makes comparisons difficult. DY-32 inner gave a workable D_e , but was not in saturation. If this sample is indeed very old then it is concluded that it shows anomalous fading.

The data for the DY-8 stratum 5 sample seem to suggest it is in saturation, but this interpretation must be considered tentative, needing further experiments to establish the required understanding of the dose responses.

8 Dose-Rates and Ages

8.1 Dose-Rate Equations

Coarse (>100 μm) quartz grains that have been etched with HF will have the effective dose-contribution from α -radiation reduced to a negligible value (Fleming 1972:41). The total dose received by coarse quartz grains extracted from the Diring Yuriakh quartzites will come from gamma radiation from decaying U, Th and K in the surrounding sediment, and beta radiation from decaying U, Th and K within the rocks themselves. There is also a small contribution from cosmic rays.

The gamma dose-rate from the surrounding sediment, R_γ , can be calculated from

$$R_\gamma = \frac{(d_{\gamma K} W_K + d_{\gamma U} W_U + d_{\gamma Th} W_{Th})}{(1 + H_\gamma \Delta)} \quad (8.1)$$

Where $d_{\gamma K}$, $d_{\gamma U}$, and $d_{\gamma Th}$ are the gamma dose-rate coefficients for K (0.202 $\text{Gy}\cdot\text{ka}^{-1}/\%K_2O$), U (0.1136 $\text{Gy}\cdot\text{ka}^{-1}/\mu\text{g}\cdot\text{g}^{-1}$), and Th (0.0521 $\text{Gy}\cdot\text{ka}^{-1}/\mu\text{g}\cdot\text{g}^{-1}$) respectively. W_K is the weight percentage of K_2O for dry sediment, while W_U and W_{Th} are the concentrations of U, and Th respectively ($\mu\text{g}/\text{g}$). H_γ is the absorption coefficient for gamma rays of water relative to that of dry sediment ($H_\gamma=1.14$) and Δ is the ratio of water mass/dry sediment mass (Aitken 1988). The values given for the dose-rate coefficients are from Nambi and Aitken (1986), and are for situations where there is no radon or thoron loss.

The internal beta dose-rate, R_β , from within the rocks themselves can be calculated from

$$R_\beta = \frac{(d_{\beta K} W_K f_K + d_{\beta U} W_U f_U + d_{\beta Th} W_{Th} f_{Th})}{(1 + H_\beta \Delta)} \quad (8.2)$$

Where d_{BK} , d_{BU} , and d_{BTh} are the beta dose-rate coefficients for K ($0.676 \text{ Gy}\cdot\text{ka}^{-1}/\%K_2O$), U ($0.147 \text{ Gy}\cdot\text{ka}^{-1}/\mu\text{g}\cdot\text{g}^{-1}$), and Th ($0.0286 \text{ Gy}\cdot\text{ka}^{-1}/\mu\text{g}\cdot\text{g}^{-1}$) respectively. H_g is the ratio of stopping powers of β particles of water to dry sediment (1.25) and Δ is the ratio of water mass/dry sediment mass (Berger 1988:16-17). For the quartzites there is no correction for water content ($\Delta=0$). f_x are the fractions of the infinite matrix β dose-rate actually absorbed by the grains; these depend on the grain size and β energy and have been calculated by Mejdahl (1979).

Cosmic rays make a small but not negligible contribution to the total dose-rate, which is a function of depth and can be calculated using the formula of Prescott and Hutton (1988). For the stratum 2 quartzites, assuming they had stayed around 1 m below the surface, R_c would be approximately 0.15 Gy/ka. The stratum 5 quartzite was collected about 4 m below the surface, so the R_c for this depth was calculated to be 0.05 Gy/ka. There may have been different depths of material above these samples in the past, so the average R_c value used in dose-rate calculations for all samples was 0.10 Gy/ka.

The ages for the Diring Yuriakh coarse quartz grains were calculated using the following equation:

$$\text{Age} = \frac{D_e}{R_\gamma + R_\beta + R_c} \quad (8.3)$$

8.2 Dose-Rate Calculations

The K, U, and Th concentrations and the water content estimates of both rocks and sediments are presented in Table 7.1. Where measured values were not available reasonable estimates were made. The calculated beta, gamma and total dose-rates are given in Table 7.2.

The gamma dose-rate affecting the DY-31 and DY-32 (Stratum 2) rocks

Table 8.1 Values for Dosimetry

<u>Stratum</u>	<u>Sample #</u>	<u>%K₂O</u>	<u>U(μg/g)</u>	<u>Th(μg/g)</u>	<u>Δ^a</u>
2	DY-32 (whole rock)	2.70	0.4 ± 0.06	0.52 ± 0.07	
	DY-31 (whole rock)	0.01	0.03 ± 0.01	0.03 ± 0.03	
3	DY-23 (sediment)	3.16	0.77 ± 0.06	3.0 ± 0.2	0.2 ± 0.1
5	DY-8 (whole rock)	5.76	3.0 ± 0.5	24.0 ± 1.8	
6	DY-22 (sediment)	2.91	1.17 ± 0.06	*3.5 ± 0.2	0.2 ± 0.1

Potassium contents were from commercial atomic absorption analysis with uncertainties of about 5 %. Uranium and Thorium were from delayed neutron analysis and neutron activation analysis respectively, except for DY-8 for which they were from thick-source alpha counting.

^a estimated ratio of water mass/dry sediment mass based on the usual saturated water content of sands of 30% as the sediments were in permafrost

* estimated value

Table 8.2 Lower Limit Age Calculations

<u>Stratum</u>	<u>Sample</u>	<u>D_e (Gy)</u>	<u>R_β^a</u>	<u>R_γ^b</u>	<u>R_c^c</u>	<u>R_{γ+β+c}</u>	<u>Age(ka)</u>
2	DY-32 (Inner IR)	440 ± 90	1.7	0.5	0.1	2.3	--- ^d
	DY-31 (TL)	>105	0.1	0.5	0.1	0.7	>150
5	DY-8 (IR)	>400	4.6	0.73	0.1	5.4	>74

^a Beta dose-rate (Gy/ka)

^b Gamma dose-rate (Gy/ka)

^c Cosmic dose-rate (Gy/ka)

^d No age was calculated for this sample

was difficult to determine from the available data. They were collected from within stratum 2, which is composed mainly of pebbles with some sediment in between that is probably similar to DY-23 (Alekseev et al 1990:10-11). Many of the pebbles are quartzite similar to DY-31, and so have low concentrations of K, U, and Th. If DY-31 and DY-32 were surrounded by an infinite matrix of DY-23 sediment, the gamma dose-rate would be 0.72 Gy/ka, but because of the surrounding low dose-rate pebbles, it was decided a value of 0.5 Gy/ka was more likely.

The DY-8 quartzite was on top of what seemed like stratum 4 sediment (D.J. Huntley, personal communication). No analyses were available for Stratum 4, but since this material is similar to stratum 6 the values for it have been used instead. The gamma dose-rate for the stratum 6 sediment was 0.73 Gy/ka.

8.3 The Ages

The equivalent dose limits, obtained as described earlier, the dose-rates, and the ages calculated for them are presented in *Table 8.2*.

Due to the nature of the problem being explored high-precision in the dose-rate and D_0 calculations was not attempted.

The three calculated ages should be regarded with caution. All three dates refer to the amount of time, at the calculated dose-rates, that it would take for the sample to go into saturation. It is unclear whether or not the stratum 2 samples were exposed to sufficient sunlight at deposition to empty relevant electron traps.

The TL age on quartz from DY-31 (stratum 2) is >150 ka, however, experiments reported earlier suggest that it is unlikely that the TL signal of this quartzite would be significantly reduced by sunlight exposure before

deposition. No age was calculated for DY-32 inner (stratum 2). This control sample should have been in saturation because of its assumed age and because the quartz came from inside the rock, and it is likely that even a long sunlight exposure would not be able to penetrate this far into the quartzite. That it is not in saturation is probably due to anomalous fading.

The 1.4 eV (IR diode) age for DY-8 (stratum 5) was > 74 ka. There are two reasons why this age may not be correct; it may not have been exposed to sufficient sunlight at deposition, and the equivalent dose determination depends on the model used to interpret the single aliquot data.

9 Conclusions

9.1 Conclusions

It appears that it may be possible to use the luminescence dating techniques developed for sediment dating to date the last time quartzites were exposed to light; however, it will not be easy. Sunlight does not penetrate very deeply into these quartzites, perhaps emptying the traps for only a few mm for a year's exposure and much less for a day. The observed luminescence was weak and a variety of behaviour was observed for the different rocks.

On the positive side, quartz grains can be conveniently removed by successive HF treatments. The stimulated luminescence plotted against the HF layer depth provides information about how far light penetrated into the sample in the past. This should also show which layers have grains with traps in saturation, to aid in selecting grains for D_e determinations.

The best results were obtained using quartz with feldspar inclusions that could be stimulated with 1.4 eV (IR diode) excitation. This was useful as feldspars become saturated at higher doses than quartz, and can thus be used to date older samples. The 2.4 eV (Ar laser) excitation could not be used to determine equivalent doses because data was too scattered in one instance, and the luminescence intensity of samples with different treatments was too similar in the other. It is probably not possible to use TL dating for these quartzites as the sunlight penetration only empties relevant traps for the outermost layers.

9.2 Archaeological Conclusions

Many more samples need to be measured before any firm conclusions about the age of Diring Yuriakh can be drawn. This study cannot lead to any useful statement as to the age of the occupation. The indication of the one stratum 5 result is that it is older than about 74 ka, older than the earliest established sites in this part of Siberia which are 30-40 ka.

It would be useful to collect more quartzite samples, specifically, larger quartzites and some of the clear vein quartz, to provide dates for Diring Yuriakh.

9.3 Recommendations for Future Work

There were two types of quartzites observed in these experiments; ones that contained quartz that responded to 1.4 eV (IR diode) stimulation, and ones that did not.

As most of the quartzites contained quartz that did not respond to 1.4 eV stimulation, the reason why the DY-31 Ar laser D_e experiments were unsuccessful needs to be understood. Specifically, the Ar laser emission spectra of the extracted quartz grains (especially DY-31) needs to be understood in order to find the optimum filter combination.

To better understand the DY-32 results, anomalous fading tests are needed to see why it was not in saturation.

More dates are needed from stratum 5 quartzites. More quartzites need to be sampled to see if their quartz grains have feldspar inclusions for IR diode dating.

Equivalent doses also need to be determined for the stratum 5 quartzites that have been exposed to sunlight for 1 year.

For luminescence dating of unheated quartzites in general, equivalent

doses need to be determined for a number of quartzites collected from known age contexts to test for accuracy.

It is hoped that the research presented in this thesis will provide a useful starting point for future work which will better establish the use of luminescence dating of quartzite as a useful tool for geologists and archaeologists.

Appendix A: Equipment

The TL Apparatus

The TL measurement apparatus used is similar to the Oxford type described in Aitken (1985:4-5), and is shown in *Figure A.1*. The samples are heated in an inert gas atmosphere (argon) at a preset constant rate (usually 5 °C/s) up to a maximum temperature (usually 500 °C). Photons emitted from the sample are first filtered through selected light filters then are measured using an EMI 9635QB photomultiplier (PM) tube and photon counting electronics (manufacturers addresses are given at the end of this appendix). Photon counts were recorded using an 8086 microcomputer equipped with a multichannel scaling board ("The Nucleus" PCA board). This board is controlled by an external BASIC program which writes the recorded data to a file. This program can also plot the photon count-rate against the sample temperature to form a "glow curve" (see *Figure 2.1*).

The 2.4 eV Excitation (Ar Laser) Apparatus

A schematic of the measurement chamber is shown in *Figure A.2*. A Spectra-Physics model #165 Ar laser was used. For all experiments in this thesis the laser was set to emit photons with an energy of 2.41 eV (wavelength of 514.5 nm). The beam from this laser was expanded, using a pair of converging lenses, for two reasons. First, the beam had to be large enough to cover a 1 cm diameter sample disk. Secondly, the central portion of the beam has a fairly uniform intensity so this portion was selected to illuminate the samples. The laser beam first passed through two input filters (F1). The photons emitted from the sample were filtered with selected light filters

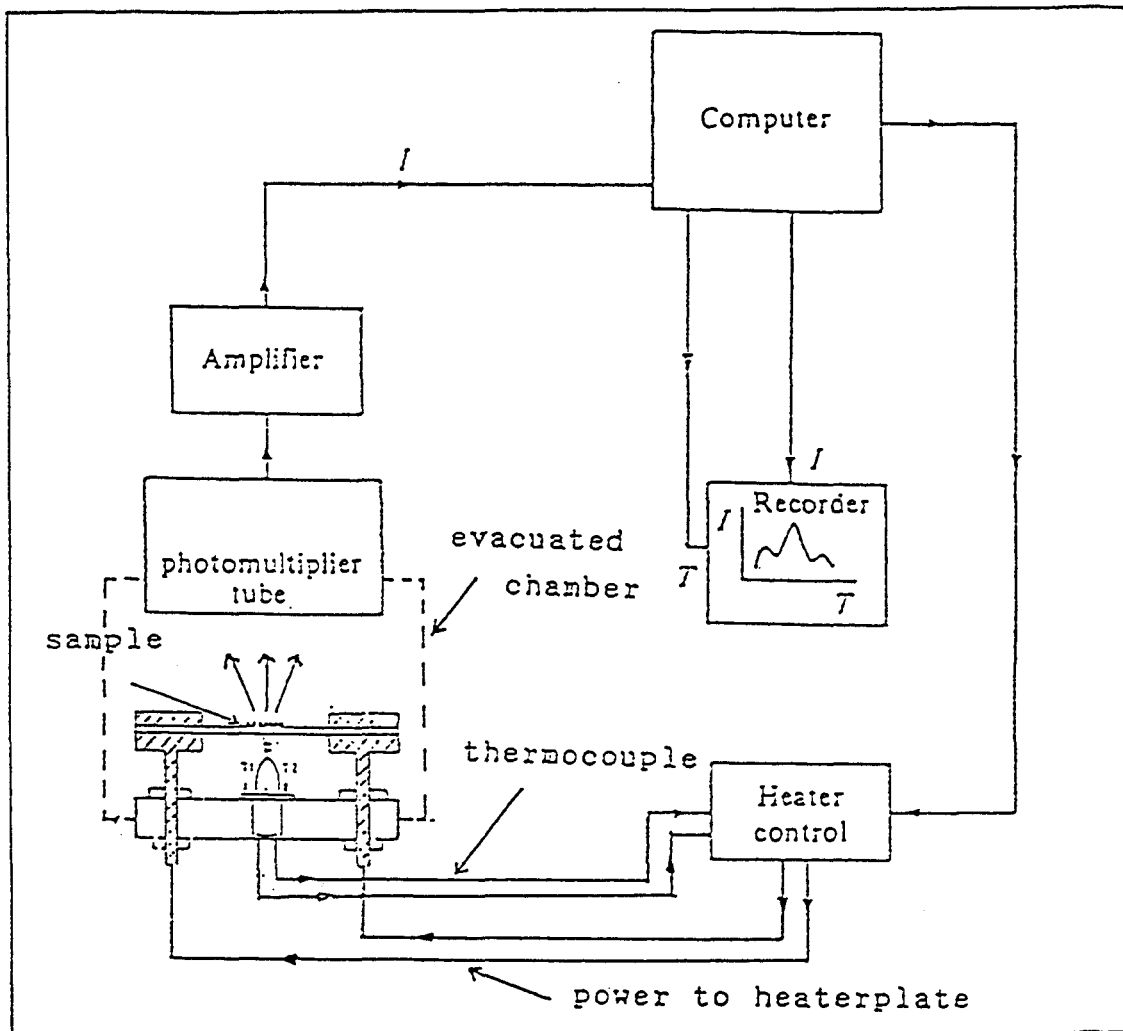

Figure A.1: The TL measurement apparatus. Samples are heated in the chamber and photons measured by the photomultiplier tube are recorded by an 8086 microcomputer equipped with a multichannel scaling board (from Short 1993, with permission).

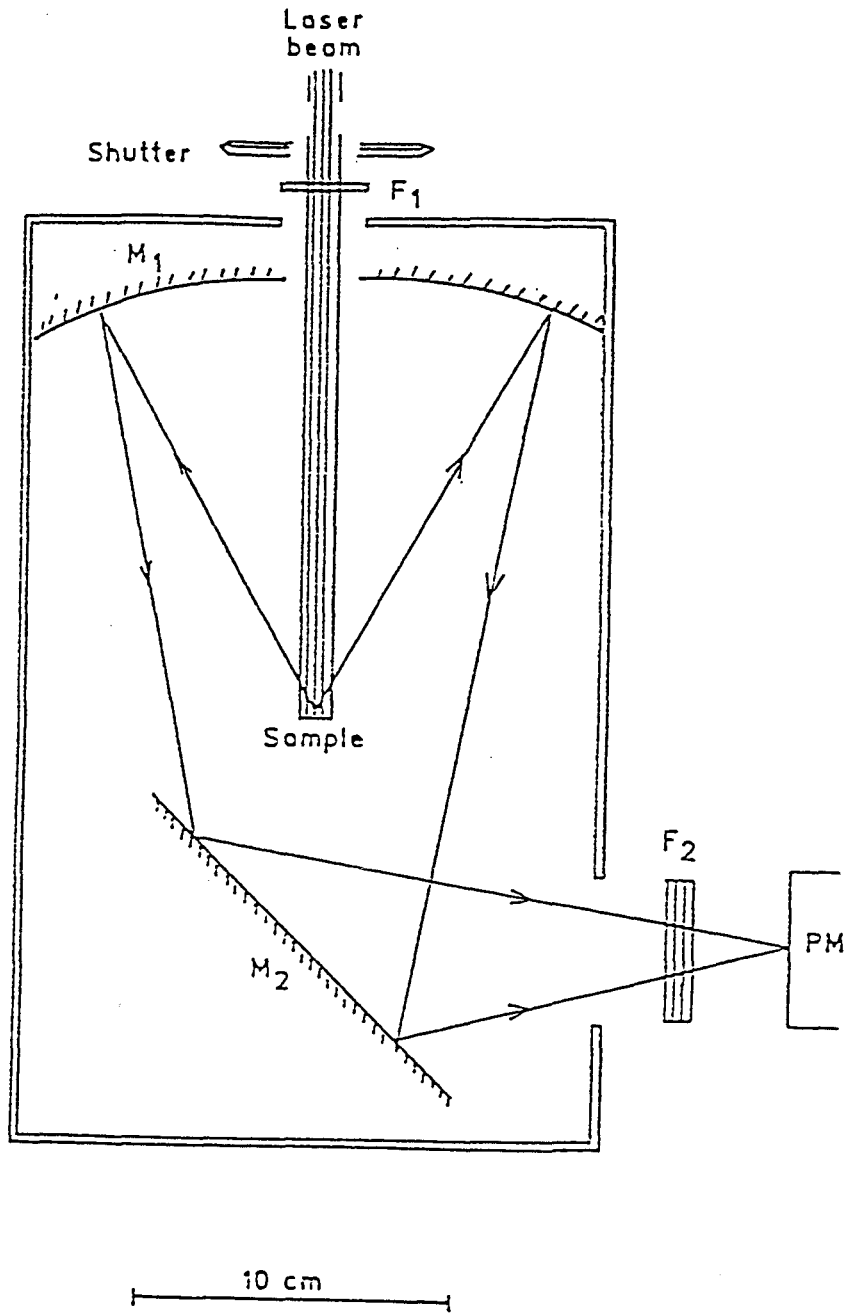

Figure A.2: The 2.4 eV (Ar laser) measurement apparatus. The laser beam passes through the shutter and the input filters (F_1 , GG-475 + 4-96 filters) before reaching the sample. Light from the sample is focussed by two mirrors (M_1 and M_2) then passes through output filters (F_2) before reaching the photomultiplier tube (PM) (from Ditlefson and Huntley, Radiation Measurements, in press).

(F2), specifically a Schott UG-11 and a Kopp 7-59 filter or two Schott UG-11 filters which stopped unwanted energy photons, including scattered photons from the laser. The photons that passed through the filters were then measured and recorded with a PM tube and an 80286 microcomputer equipped with a multichannel scaling board. The photon counts measured by the PM tube are plotted against the time of sample exposure to the laser to form a "shine-down curve" (an example is shown in *Figure 5.4*).

The 1.4 eV Excitation (IR Diode) Apparatus

This measurement apparatus is the same as that just described except that infrared light-emitting diodes were used for excitation. It is described in Ollerhead (1993) and illustrated in *Figure A.3*. An array of 16 diodes (model OD50L, 50 mW diodes emitting photons at 1.4 eV, peak 880 nm, range 780-980 nm, from Opto Diode Corporation) were mounted inside the sample chamber. The diode light was first filtered through a Schott RG-630 filter before reaching the sample. The light from the sample then passed through a Schott BG-39 filter to filter out unwanted scattered photons, and a Kopp 5-57 pass-band filter was used to remove the plagioclase feldspar emissions at 2.2 eV (570 nm) before reaching an EMI 9635QB PM tube. The measured emission is expected to be essentially entirely the 3.1 eV (405 nm) band characteristic of potassium feldspars. A shine-down curve similar to the Ar laser shine-down curve was obtained; examples are shown in *Figure 5.5*.

Laboratory Irradiations

All samples were irradiated using a Co-60 Gammacell (manufactured by Atomic Energy of Canada Ltd.). Sample disks were put into aluminum holders which were then lowered into the Gammacell where they were exposed to the

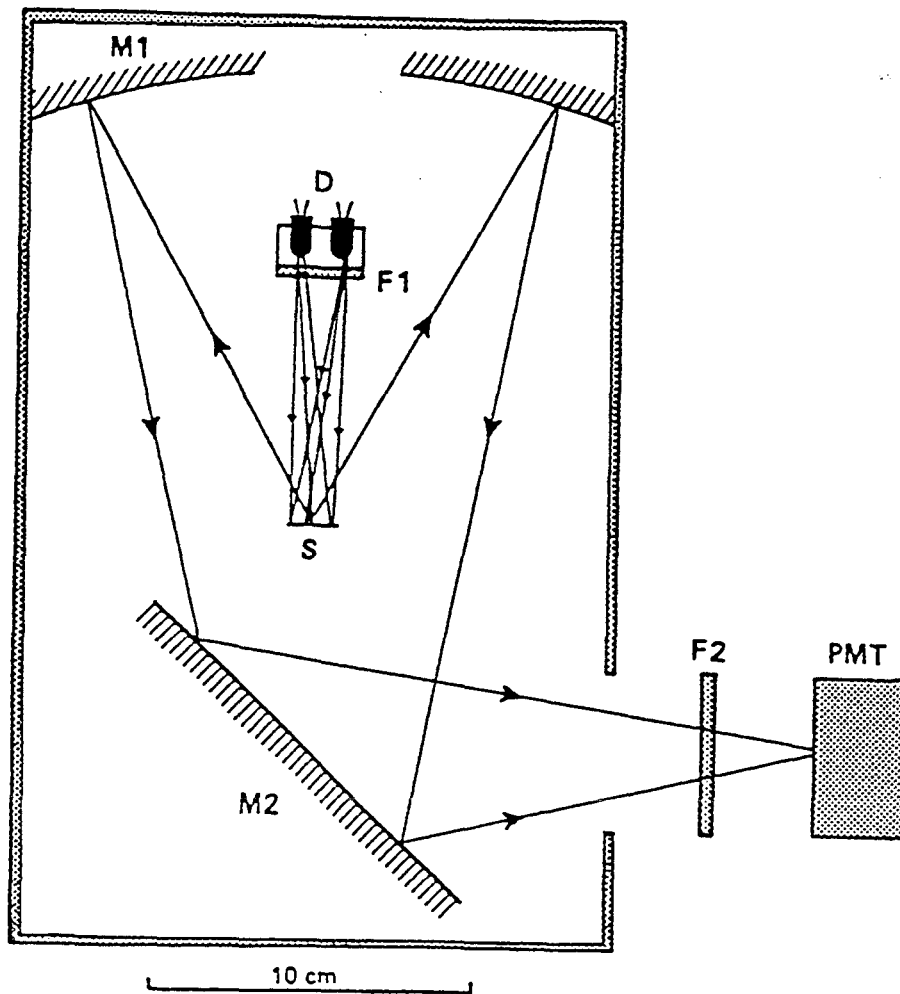

D diodes
 M mirror
 S sample
 F filter
 PMT photomultiplier tube

Figure A.3: The 1.4 eV (IR diode) measurement apparatus. Light from the diodes (D) passes through input filters (F_1) before reaching the sample (S); the light from the sample is focussed by two mirrors (M_1 and M_2) then passes through output filters (F_2) before reaching the photomultiplier tube (PMT) (from Ollerhead *et al* 1994).

gamma radiation emitted from the rods of Co-60. The Gammacell is equipped with a timer which controls the length of time the sample is exposed to the gamma radiation. The dose-rate to a sample decreases with time due to the decay of Co-60; in May, 1994, it was 0.48 Gy/minute.

Lamp for Bleaching

The samples used for the Ar and TL experiments were bleached in direct sunlight, while the samples for the IR diode experiments were bleached with a quartz-halogen incandescent lamp equipped with a Schott RG-715 filter. The samples were placed in a ring in a holder which was continuously rotated to ensure that each sample received a similar amount of light from the lamp.

Addresses of Manufacturers

Kopp Glass Inc., 2108 Palmer St., Pittsburgh, Pennsylvania, 15218, U.S.A.

Opto diode Corp., 914 Tourmaline Dr. Newbury Park, California, 18642, U.S.A.

Schott Glass Technologies Inc., 400 York Ave., Duryea, Pennsylvania,
18642 U.S.A.

Spectra-Physics, 1250 W.Middlefield Rd., Mountain View, California,
94042-7303, U.S.A.

Tennelec/Nucleus Inc., P.O. Box 2561, 761 Emory Valley Road, Oak Ridge, TN
37831-2561, U.S.A.

(EMI) Whittaker Corp., 80 Express St., Plainview, L.I., N.Y., 11803, U.S.A.

Appendix B: Sample List

<u>Stratum</u> *	<u>Sample Number</u>	<u>Description</u>
6	DY-22	Sediment.
5	DY-8, DY-9	Pebbles, where overlain by stratum 6.
	DY-25, DY-26	Pebbles, where overlain by stratum 14. An unconformity only present at certain areas of the site.
	DY-44	Pebble, exposed to sunlight on the surface of stratum 5, summer 1991 to August 1992.
3	DY-23	Sediment.
2	DY-1a,b,c,d	Pebbles.
	DY-31, DY-32	Pebbles, broken open when collected to see their quality.

* See Chapter 3 for more information about the stratigraphy and stratum designations.

Appendix C: Emission Spectra

To help understand what is happening to the quartz grains when they are stimulated by heating (TL) or 1.4 eV excitation, experiments were undertaken to measure the emission spectra.

DY-31 TL Emission Spectra

The TL emission spectra of DY-31 ($<425 \mu\text{m}$), which did not respond to the 1.4 eV stimulation, were measured at the University of Adelaide, Australia (R. Scholefield and J.R. Prescott, personal communication and thanks). *Figure C.1* shows the spectrum as a function of temperature. This is an average of 7 samples, each annealed then given a 300 Gy dose. It is seen that the emission is dominated by a band at 2.5 eV (500 nm).

If the emission spectra for DY-31 is similar when stimulated by an Ar laser (although Huntley *et al* (1988) did not find this), one can begin to understand why there was such a low luminescence intensity in the Ar laser D_e measurements (*Section 6.1.1*). The output filters were a Schott UG-11 and a Kopp 7-59, which together only transmit photons between 300 and 380 nm, which would have blocked out the vast majority of emitted photons.

DY-1c Emission Spectrum with 1.4 eV (IR diode) Excitation

The emission spectrum from DY-1c, which did respond to 1.4 eV stimulation, was measured using the method of Jungner and Huntley (1991). This was done by measuring a single disk coated with 30 mg of 150-180 μm quartz grains from HF layers 9-11. The sample was stimulated by the IR diode array 16 times, for 5 seconds each time. The first measurement was with a BG-

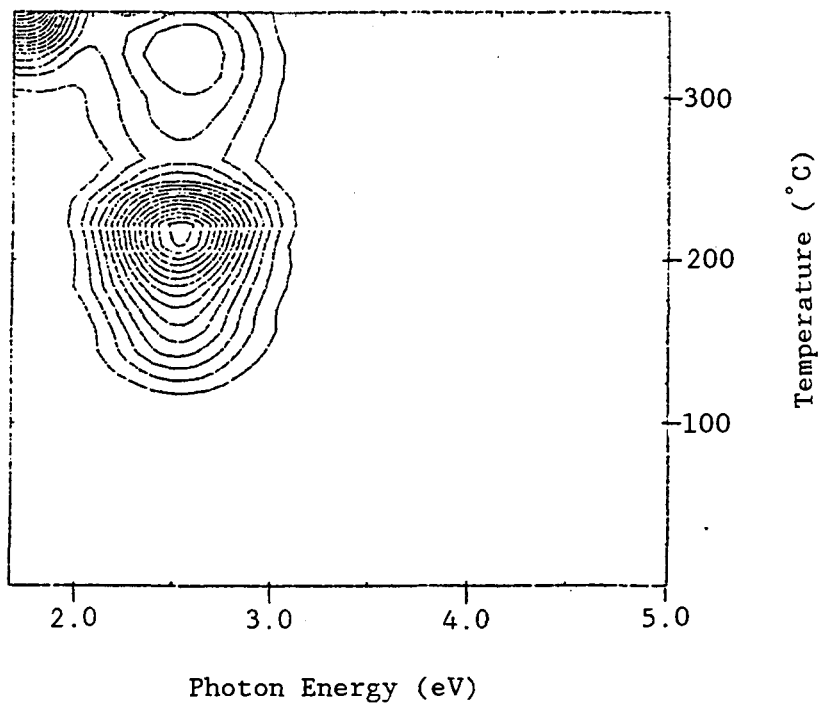
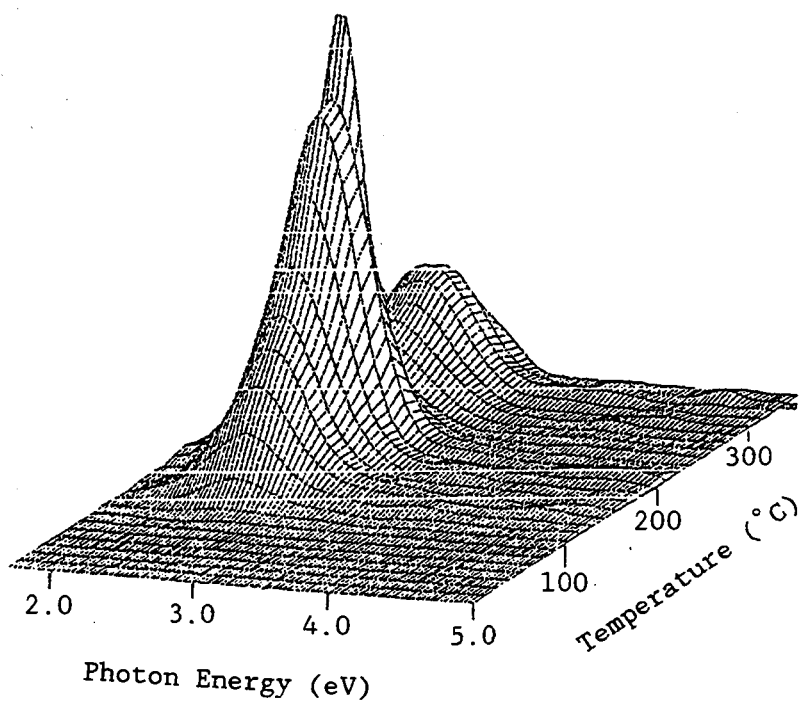

Figure C.1 : TL emission spectra of DY-31 <math><425 \mu\text{m}</math> quartz grains plotted against temperature. The graphs are an average of 7 measurements. Each sample was annealed then given a 300 Gy dose before measurement. The measurements were undertaken at the University of Adelaide, Australia (by R. Scholefield and J. R. Prescott).

39 filter between the sample and the PM tube. A BG-39 filter lets most photons with wavelengths between about 340 and 600 nm pass through to the PM tube, but blocks out all others (including the photons from the diodes at 880 nm). A long-pass filter, which blocked out photons below about 350 nm, was then put between the sample, the BG-39 filter and the PM tube. The disk was measured again, and the light intensity recorded. Then the long-pass filter was removed and another one, which blocked photons below about 375 nm was added and the disk was measured again. This process continued with 10 more long-pass filters, each one cutting out photons with longer and longer wavelengths. In the middle and at the end of these measurements the disk was measured with just the BG-39 filter to see how much the intensity had decreased due to the multiple IR diode measurements.

The light intensity for each measurement was corrected for the intensity loss due to repeated measurements, the efficiency of the PM tube, and for the photons blocked at different wavelengths by the BG-39 filter (but not for the unknown reflectivity of the two mirrors shown in *Figure A.6*). *Figure C.2* shows the resulting emission spectrum. The two dominant peaks correspond closely to the emission spectra of potassium feldspar (410 nm) and plagioclase feldspar (570 nm) (Huntley et al 1991, Jungner and Huntley 1991), thus lending support to the idea that it is feldspar inclusions in quartz that are being measured.

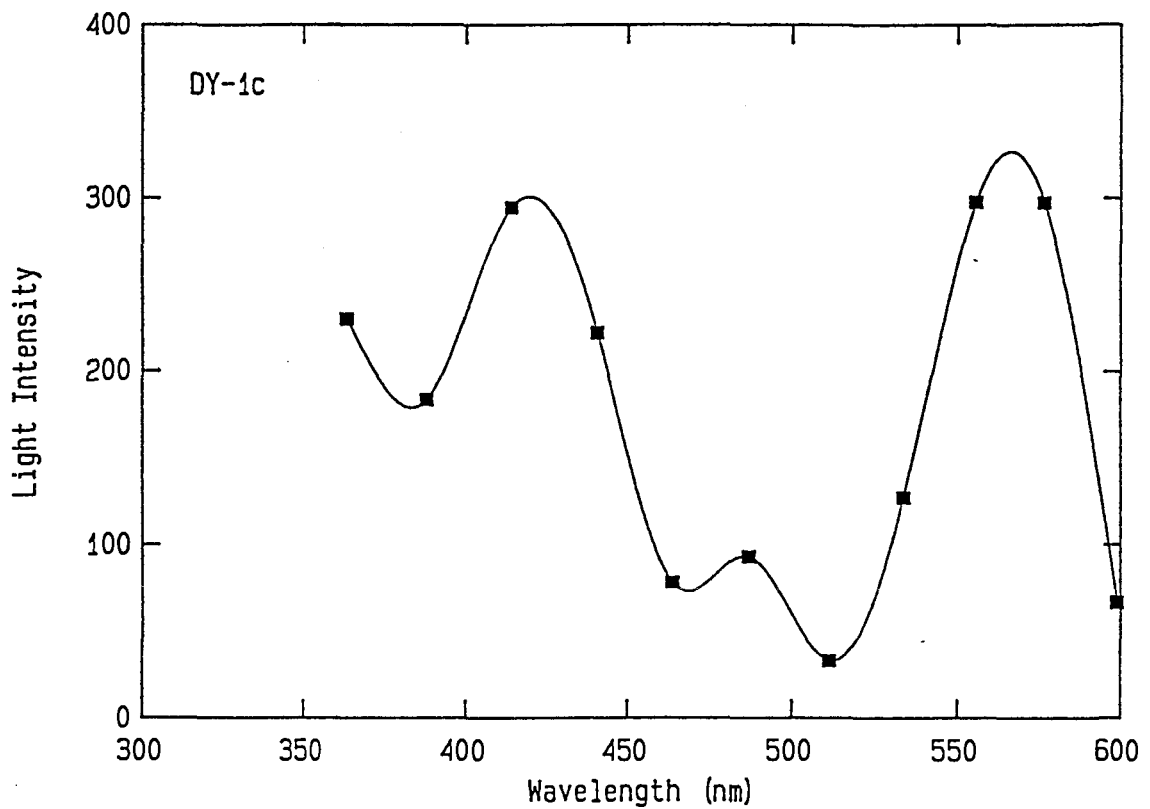

Figure C.2: Emission spectrum of DY-1c, under 1.4 eV excitation. A single 30 mg aliquot of 150-180 μm quartz grains was used. Each point is the sum of 5 s of data, and is corrected for intensity loss due to repeated measurements, efficiency of the PM tube, and any loss due to the absorption of the BG-39 filter.

References Cited

- Ackerman, R.E., and R.L. Carlson
1991 "Diring Yuriakh: An Early Palaeolithic Site in Yakutia." *Current Research in the Pleistocene* 8:1-2.
- Aigner, J.S.
1986 "The Age of Zhoukoudian Locality 1: the Newly Proposed O¹⁸ Correspondences." *Anthropos* 23:157-173.
- Aitken, M.J.
1974 *Physics and Archaeology*. Clarendon Press, Oxford. 291 pgs.
1985 *Thermoluminescence Dating*. Academic Press, London. 359 pgs.
1990 *Science-Based Dating in Archaeology*. Longman, London. 274 pgs.
1992 "Optical Dating." *Quaternary Science Reviews* 11:127-131.
- Aitken, M.J., and J. Xie
1992 "Optical Dating Using Infrared Diodes: Young Samples." *Quaternary Science Reviews* 11:147-152.
- Alekseev, M.N., V.A. Kamaletdinov, Ch. Siegert, O.V. Grinenko, Z.N. Gribidenko, G.F. Gravis, E.A. Shamshina, and Yu. V. Arkhipov.
1990 "Problems of the Geology of the Diring Yuriakh Palaeolithic Site." Report prepared for the Academy of Sciences of the USSR, Siberian Department, Yakutsk Institute of the Geological Sciences. Translated by S.F. Strujkov.
- Berger, G.W.
1988 "Dating Quaternary Events by Luminescence." *Geological Society of America Special Paper* 227:13-50.
- Chemical Rubber Publishing Company
1985 *CRC Handbook of Chemistry and Physics*. 65th edition. CRC Press, Boca Raton, Florida.
- Duller, G.A.T.
1991 "Equivalent Dose Determination Using Single Aliquots." *Nuclear Tracks and Radiation Measures*. 18(4):371-378.
1992 "Comparison of Equivalent Doses Determined by Thermoluminescence and Infrared Stimulated Luminescence for Dune Sands in New Zealand." *Quaternary Science Reviews* 11:39-43.
- Ebright, C.A.
1987 "Quartzite Petrography and its Implications for Prehistoric Use and Archaeological Analysis." *Archaeology of Eastern North America* 15:29-45.
- Fleming, S.J.
1969 *The Acquisition of Radioluminescence by Ancient Ceramics*. Unpublished D.Phil Thesis, University of Oxford.

- 1979 *Thermoluminescence Techniques in Archaeology*. Clarendon Press, Oxford.
- Godfrey-Smith, D.I., Huntley, D.J., and W.-H. Chen
 1988 "Optical Dating Studies of Quartz and Feldspar Sediment Extracts." *Quaternary Science Reviews* 7:373-380.
- Huntley, D.J., D.I. Godfrey-Smith, and M.L.W. Thewalt
 1985 "Optical Dating of Sediments." *Nature* v.313, 105-107.
- Huntley, D.J., D.I. Godfrey-Smith, M.L.W. Thewalt, J.R. Prescott, and J. T. Hutton
 1988 "Some Quartz Thermoluminescence Spectra Relevant to Thermoluminescence Dating." *Nuclear Tracks and Radiation Measures* 14:27-33.
- Huntley, D.J., J.T. Hutton, and J.R. Prescott
 1993a "The Stranded Beach-Dune Sequence of South-East South Australia: A Test of Thermoluminescence Dating, 0-800 ka." *Quaternary Science Reviews* 12:1-20.
- 1993b "Optical Dating Using Inclusions Within Quartz Grains." *Geology* 21:1087-1090
- Hurlbut, C.S.Jr., and C. Klein
 1977 *Manual of Mineralogy*, 19th edition. John Wiley and Sons, Inc., New York.
- Hütt, G., I. Jaek, and J. Tchonka
 1988 "Optical Dating: K-feldspars Optical Response Stimulation Spectra." *Quaternary Science Reviews* 7:381-385.
- Jungner, H., and D.J. Huntley
 1991 "Emission Spectra of Some Potassium Feldspars Under 633 nm Stimulation." *Nuclear Tracks and Radiation Measures* 18:125-126.
- Klein, R.G.
 1989 *The Human Career*. The University of Chicago Press, Chicago. 524 pgs.
- Krynine, P.D.
 1948 "The Megascopic Study and Field Classification of Sedimentary Rocks." *Journal of Geology* 56:130-165.
- Leakey, L.S.B., J.F. Evernden, and G.H. Curtis
 1961 "Age of Bed 1, Olduvai Gorge, Tanganyika." *Nature* 202:308-312.
- Mejdahl, V.
 1979 "Thermoluminescence Dating: Beta-Dose Attenuation in Quartz Grains." *Archaeometry* 21(1):61-72.
- Mochanov, Y.A.
 1988 "The Most Ancient Palaeolithic of the Diring and the Problem of a Nontropical Origin for Humanity." *Archaeology of Yakutia, Yakutsk*. Translated by R.L. Bland, *Arctic Anthropology* 1993, 30:22-53.

- Mochanov, Y.A.
 1992 "The Earliest Palaeolithic of Northeastern Asia and the Problem of an Extratropical Cradle of Man" Paper presented at the 45th Annual Northwest Anthropology Conference, Simon Fraser University.
- Nambi, K.S.V., and M.J. Aitken
 1986 "Annual Dose Conversion Factors for TL and ESR Dating." *Archaeometry* 28:202-205.
- Okladnikov, A.P., and G.A. Pospelova
 1982 "Ulalinka, the Oldest Palaeolithic Site in Siberia" Translated by O.V. Pavlova, *Current Anthropology* 23(6):710-712.
- Ollerhead, J.
 1993 *The Evolution of Buctouche Spit, New Brunswick, Canada*. Unpublished Ph.D. thesis, The University of Guelph.
- Ollerhead, J., D.J. Huntley, and G.W. Berger
 1994 "Luminescence Dating of Sediments from Buctouche Spit, New Brunswick." *Canadian Journal of Earth Sciences* 31:523-531.
- Rhodes, E.J.
 1988 "Methodological Considerations in the Optical Dating of Quartz." *Quaternary Science Reviews* 7:395-400.
- Prescott, J.R., and J.T. Hutton
 1988 "Cosmic Ray and Gamma Ray Dosimetry for TL and ESR." *Nuclear Tracks and Radiation Measures*. 14:223-227.
- Short, M.A.
 1993 *Some Aspects of Optically Stimulated Luminescence for Sediment Dating*. Unpublished M.Phil. Thesis, The University of Hong Kong.
- Short, M.A., and D.J. Huntley
 1992 "Infrared Stimulation of Quartz" *Ancient TL* 10(2):19-21.
- Singhvi, A.K., Y.P. Sharma, and D.P. Agrawal
 1982 "Thermoluminescence Dating of Sand dunes in Rajasthan, India." *Nature* 295:313-315
- Skolnick, H.
 1965 "The Quartzite Problem." *Journal of Sedimentary Petrology* 35:12-21.
- Smith, B.W., E.J. Rhodes, S. Stokes, N.A. Spooner, and M.J. Aitken
 1990 "Optical Dating of Sediments: Initial Quartz Results from Oxford." *Archaeometry* 32(1):19-31
- Spell, T.L. and I. McDougall
 1992 "Revisions to the age of Brunhes-Matuyama Boundary and the Pleistocene Geomagnetic Polarity Timescale." *Geophysical Research Letters* 19:1181-1184.
- Spooner, N.A.
 1993 *The Validity of Optical Dating Based on Feldspar*. Unpublished D.Phil. Thesis, University of Oxford.