

**PHASE TRANSITIONS IN RIGID STRINGS
WITH LIQUID-CRYSTAL-LIKE ORDER**

by

XIAOAN ZHOU

B. Sc. Hunan Normal University, 1981

M. Sc. China University of Science and Technology

& Hunan Normal University 1986

Thesis Submitted in Partial Fulfillment of
the Requirements for the Degree of
Doctor of Philosophy
in the Department
of
Physics

© XIAOAN ZHOU, 1990

SIMON FRASER UNIVERSITY

June 1990

All rights reserved. This work may not be
reproduced in whole or in part, by photocopy
or other means, without permission of the author

APPROVAL

Name: XIAOAN ZHOU
Degree: Doctor of Philosophy
Title of Thesis: Phase Transitions in Rigid Strings with Liquid-Crystal-like Order.

Examining Committee:

Chairman: Dr. E.D. Crozier

Dr. K.S. Viswanathan
Senior Supervisor

Dr. D.H. Boal

Dr. Gordon W. Semenov
University of British Columbia

Dr. Nathan Weiss
External Examiner
University of British Columbia

Date Approved: June 12, 1990

PARTIAL COPYRIGHT LICENSE

I hereby grant to Simon Fraser University the right to lend my thesis, project or extended essay (the title of which is shown below) to users of the Simon Fraser University Library, and to make partial or single copies only for such users or in response to a request from the library of any other university, or other educational institution, on its own behalf or for one of its users. I further agree that permission for multiple copying of this work for scholarly purposes may be granted by me or the Dean of Graduate Studies. It is understood that copying or publication of this work for financial gain shall not be allowed without my written permission.

Title of Thesis/Project/Extended Essay

Phase Transitions in Rigid Strings with Liquid-Crystal-Like

Order

Author:

(Signature)

Xiaoan ZHOU

(Name)

Jan. 16, 1991

(Date)

ABSTRACT

A model of rigid strings with liquid-crystal-like order is proposed. Both its classical and quantum mechanical properties including renormalization are analyzed. It is shown that the model describes an off-shell generalization of a theory of minimal surfaces (or string worldsheets). A new kind of local symmetry, the area-preserving symmetry, plays an important role in the model. A saddle point approximation is employed and fluctuations around the saddle point are considered. By analyzing the singularities of the free energy of a gas of rigid strings, it is shown that the Hagedorn temperature T_H does not coincide with the critical temperature T_c , at which the effective string tension starts vanishing. An intermediate region (a rough phase) is shown to exist which separates a smooth phase from a crumpled phase. The phase diagram of the model is worked out. It turns out that the phase structure agrees nicely with that obtained from the numerical simulations of discretized random surfaces with bending rigidity. Implications for the finite temperature phase transitions in QCD are discussed.

ACKNOWLEDGEMENTS

I am very grateful to my supervisor, K.S. Viswanathan, for suggesting me to look into the related rigid string model and working alongside with me to get me started.

I would like to express my sincere thanks to Professor G.W. Semenoff for useful discussions and encouragement.

I am especially pleased to thank Professor M. Wortis for helpful discussions on membranes.

I would like to thank Professor N. Weise for a discussion on QCD phase transitions.

I would like to thank Professor Evan Evans for a discussion on liquid crystals.

Finally, I would like to thank M. Rao, E. Levinson, Ling Miao and Daming Liu for useful discussions.

DEDICATION

To My Parents

To My Wife

To My Daughter

TABLE OF CONTENTS

APPROVAL	ii
ABSTRACT	iii
ACKNOWLEDGEMENTS	iv
DEDICATION	v
CHAPTER 1	Introduction	1-7
CHAPTER 2	Liquid Crystalline, Minimal Surface and the Area-Preserving Invariance.....	8-26
CHAPTER 3	Renormalization of the Bending Rigidity at Zero Temperature.....	27-40
CHAPTER 4	Generalized Gauge Fixing and the Saddle Point Solutions.....	41-59
CHAPTER 5	Smooth-Rough Transition.....	60-69
CHAPTER 6	A Simple Estimate of the Hagedorn Transition....	70-83
CHAPTER 7	Free Energy of a Gas of Rigid Strings.....	84-105
CHAPTER 8	Hagedorn Temperature and the Phase Diagram.....	106-119
CHAPTER 9	Discussion and Summary	120-123
APPENDIX A	ζ -Function Evaluation of $\text{Lndet}'(-\Delta)$ and $\text{Lndet}'(-\Delta/\lambda_0+1)$	124-135

APPENDIX B ζ -Function Evaluation of $\text{Lndet}'(-\Delta/\lambda_0+1)$ on
A Torus.....136-141

APPENDIX C A Derivation of (7-63).....142-145

FIGURE CAPTIONS.....146

REFERENCES147-153

FIG. 1154

FIG.A-1,A-2155

FIG. B-1156

Chapter 1

Introduction

There are common trends in statistical physics and quantum field theory. In the past, this connection has been fruitful. An example of this connection is the random walk and the propagation of free particles^[1]. One could hope for this connection in the case of the "field of force", the color-electric flux for instance, where random walks should be replaced by random surfaces. In fact, problems involving the statistics of random surfaces appear in many areas of theoretical physics, ranging from 2-d gravity and strings to condensed matter and biophysics.

In the case of the free bosonic string^[2] it is now clear that these surfaces can provide a representation of "strings", if the dimension of the embedding space is less than one^[3].

Related and perhaps more realistic random-surface theories arise in the statistical mechanical descriptions of rigid strings^[4,5], which is proposed as QCD strings, as well as membranes^[6]. In these theories the extrinsic-curvature term in the action is important in determining the properties of the theories. It has also been argued that such an extrinsic curvature term is relevant in a class of regularized string theories without tachyons^[7,8]. It might not be too surprising that an effective bosonic string theory does not

have a tachyon in its spectrum since the extrinsic curvature term might have a fermionic origin^[9], that is, it might arise as a result of integrating out fermions in the functional integrals.

Perturbative calculations indicate that the extrinsic curvature term can only govern the short distance behavior^[4,5,6,10], a situation very similar to the low temperature behavior of the 2-d Heisenberg model^[11]. Recent non-perturbative investigations of possible finite-temperature transitions of rigid strings showed that^[12] the theory has a square-root singularity at the transition, just like its counterpart, the Nambu-Goto string^[13]. A similar singularity also exists for rigid surfaces^[14].

Recently rigid surfaces and/or membranes with crystalline order have become an object of study and seem to have interesting phase structure^[15-18]. Ami and Kleinert^[15] showed that the crystalline order does not change the renormalization of the bending rigidity at short distances. On the other hand, a perturbative calculation by Nelson and Peliti^[16] showed that the effective rigidity modulus grows at large distances and predicted a crumpling transition. It is important to note that their description (the bending free energy (4) of ref. [16]) is non-covariant. Using a covariant formulation, David and Gitter^[17] arrived at a similar conclusion in a related model in the large-d limit, where an UV-stable fixed point was found, associated with a second-order crumpling

transition. Paczuski, Kardar and Nelson^[18] developed a Landau theory of the crumpling transition in which it was shown that fluctuations drive the transition first order for embedding space dimension less than 219.

In the context of fluid membranes, the surface density is in fact fixed because of the large compression modulus of the fluid. Helfrich^[19] and Forster^[20] first pointed out that tangential flows are induced by any normal displacement of the surface and incompressibility then implies a (induced) long-range couplings between the mean curvature at different points of the surface. A full renormalization group analysis by David^[21] showed that those long-range forces are in fact screened by thermal undulations beyond a length which is much smaller than the persistence length of the surface.

In this thesis, we consider a related problem, the implication of fixed trace of the metric in a model of rigid strings. The first order form of rigid strings^[4] is used and the geometrical aspect of the model is stressed. In the mathematical literature^[22], surfaces can be classified into two distinct kinds according to their mean curvatures: the minimal surfaces with vanishing mean curvature and the general surfaces with nonvanishing mean curvature. It is shown in this thesis that the model of rigid

strings with fixed trace of the metric describes an off-shell generalization of a theory of minimal surfaces. A new kind of local symmetry, the area-preserving symmetry, plays an important role in the model. In fact, for minimal surfaces, this symmetry implies a fixed trace of the metric (see Section 2.3).

Although our calculations and results may find applications in condensed matter and membranes, we will pay special attention to QCD strings^[4,5] in this thesis. The basic assumption we accept here is that the confinement of quarks in QCD is associated with the formation of an infinitely long color-electric flux tube with finite width formed by pulling a quark-antiquark pair infinitely far apart. To a good approximation, such a flux tube can be described by a string.

As demonstrated by the existence of the Nielson-Olesen vortex^[23], an infinitely long flux tube or a string can be perfectly stable classically (or/and at zero temperature). Quantum mechanically (or/and at finite temperature), however, whether it remains stable or not is an open question and depends on the effective model of strings.

Usually, one assumes that the internal degrees of freedom of the flux tube are "frozen" and concentrates on the resulting effective dynamics of the string coordinate vector field, which is local and reparametrization invariant^[24]. Here arises the trouble. According

to the Mermin-Wagner-Coleman theorem^[25], no spontaneous breakdown of global continuous symmetry, such as translation and rotation invariances, can occur in a 2-dimensional theory with local interactions. This is because the Goldstone bosons associated with the symmetry breaking always destroy the long-range order of the 2-dimensional system with local interactions. Therefore, if the Mermin-Wagner-Coleman theorem applies to the model of strings, the assumption that an infinitely long quantum flux tube of finite width exists, is self-contradictory! Adding a rigidity term to the effective action does not cure the problem^[4,5,12].

We will show in this thesis that due to the classical constraint of fixed trace of the metric, which induces effectively long-range interactions at the quantum level (see Section 4.3), the Mermin-Wagner-Coleman theorem is inapplicable for the present model. We can then study the phase transitions of the model. After a suitable gauge fixing removing the unphysical degrees of freedom, the path integral of the strings can be evaluated non-perturbatively (in a saddle point approximation) in physical dimensions to determine the phase diagram of the model. It is shown that an intermediate region exists, which separates a smooth phase from a crumpled phase. The phase diagram for the model is worked out. It turns out that the phase structure of the model is, in certain aspects, in common with that of liquid crystals. (Roughly

speaking, the existence of a smooth (or flat) phase at large scales would imply a liquid-crystal-like order. This is because the smooth (or flat) phase means both the long-range (orientational) correlation between normals to the string worldsheet and the long-range (positional) correlation of X^μ field.) This would imply that the classical constraint of fixed trace of the metric, which is a natural result for minimal surfaces, induces a liquid-crystal-like order at the quantum level. In fact, without fixing the trace of the metric, the fluctuations of metric always destroy the long-range order of the system for all finite temperatures. As a result, the system does not have a flat phase at large scales^[14]. It is in this sense that we say the model to have a liquid-crystal-like order.

The remainder of this thesis is organized as follows. In Chapter 2, we propose the model of rigid strings with liquid-crystal-like order and discuss its (classical) symmetry properties. A comparison of the model with other rigid strings, the Polyakov-Kleinert string^[4,5] and Pisarski's model^[26] is made. In Chapter 3, a generalized covariant gauge fixing procedure is devised. A saddle point solution of the lagrange multiplier is obtained for $d > 2$, and its quantum fluctuations are calculated. In Chapter 4, we discuss one possible phase transition in the model, the smooth-rough

transition. The Hausdorff dimension and the width of the string are calculated.

In Chapter 6, we estimate the Hagedorn temperature of the model under a well-motivated speculation. The Hausdorff dimension of the string sheet at the Hagedorn temperature is calculated. Chapters 7 and 8 are more mathematical but standard. In Chapter 7, computations on the path integrals and then the free energies of rigid strings on a torus and a cylinder are presented respectively. The mass spectrums for both cases are obtained. The tachyon free condition is then obtained which is consistent with the saddle point solution of Chapter 4. In Chapter 8, the Hagedorn temperature of the system is calculated more rigorously than in Chapter 6. The result agrees nicely with the simple estimate of Chapter 6. The phase diagram of the model is worked out and compared with the numerical result of discretized random surfaces. The implication for the finite-temperature phase transitions in QCD is discussed in Chapter 9.

We end this thesis with a conclusion in Chapter 9 followed by three Appendices showing the details of evaluation of the determinants of the operator $(-\Delta + \lambda_0)$ on a cylinder and a torus respectively.

Chapter 2

Liquid Crystalline, Minimal Surface and the Area-Preserving Invariance

In this chapter, we propose a model of rigid strings with liquid-crystal-like order and discuss its classical symmetry properties. In particular, we argue that the proposed model describes an off-shell generalization of the theory of minimal surfaces. We show that the model of minimal surfaces has the area-preserving invariance, besides the conformal invariance, at the classical level. A comparison of the model with other rigid strings, the Polyakov-Kleinert string and Pisarski's model, is made.

2.1 THE POLYAKOV-KLEINERT STRING

Since the Polyakov-Kleinert string^[4,5] has a close relation with the model to be proposed, we first review the former briefly. The action for the Polyakov-Kleinert string is given by, in the second-order form^[5]:

$$S^{(2nd)} = \sigma_0 \int d^2\xi \sqrt{g} + \frac{1}{2\alpha_0} \int d^2\xi \sqrt{g} K_a^{ia} K_b^{ib} \quad , \quad 2-1$$

where σ_0 is the string tension at zero temperature and has the

dimension of mass square, $1/\alpha_0$ is the dimensionless bending rigidity, g_{ab} is the induced metric and K_{ab}^i is the second fundamental form or the extrinsic curvature tensor defined by the Gauss-Weingarten formulas:

$$\begin{aligned}
 g_{ab} &= \partial_a X^\mu \partial_b X^\mu, \\
 \partial_a \partial_b X^\mu &= \Gamma_{ab}^c \partial_c X^\mu + K_{ab}^i n_i^\mu, \\
 n_i^\mu n_j^\mu &= \delta_{ij}, \quad n_i^\mu \partial_a X^\mu = 0, \\
 (a, b, c &= 1, 2; i, j = 3, 4, \dots, d; \mu = 1, 2, \dots, d).
 \end{aligned}
 \tag{2-2}$$

Using (2-2), the rigidity term in (2-1) can be rewritten as:

$$S_{\text{rig.}} = \frac{1}{2\alpha_0} \int d^2 \xi \sqrt{g} (\Delta X^\mu)^2,$$

where

$$\Delta X^\mu = (1/\sqrt{g}) \partial_a (\sqrt{g} g^{ab} \partial_b X^\mu).$$

The action (2-1) is invariant under reparametrizations:

$$\delta X^\mu = \delta \xi^a \partial_a X^\mu.$$

The extrinsic curvature term (2-3) is invariant under the transformation:

$$X^\mu \rightarrow \kappa X^\mu.$$

To obtain the equation of motion, we consider the variation:

$$X'_\mu = X_\mu(\xi^a) + \delta X_\mu(\xi^a).$$

From $\delta S = 0$, we obtain the equation of motion:

$$\begin{aligned}
\partial_a \Sigma_\mu^a &= \sigma_0 \partial_a (\sqrt{g} g^{ab} \partial_b X^\mu) + (1/\alpha_0) \partial_a [\sqrt{g} (\frac{1}{2} \partial^a X_\mu \Delta X^\rho \Delta X_\rho \\
&\quad - 2 \partial^a \partial_b X^\rho \partial^b X_\mu \Delta X_\rho - \partial^a \Delta X_\mu)] \\
&= 0
\end{aligned} \tag{2-7}$$

Conditions at boundaries, if exist, should be understood. Because of the reparametrization invariance of the action, not all of the equations of motion in (2-7) are independent. To remove the gauge degrees of freedom, one can choose an orthonormal gauge^[27]

$$\begin{aligned}
\dot{X}^2 - X'^2 &= 0, \\
\dot{X} \cdot X' &= 0.
\end{aligned} \tag{2-8}$$

In this case, Eq. (2-7) reduces to

$$\begin{aligned}
\partial_a \bar{\Sigma}_\mu^a &= \sigma_0 \partial_a \partial^a X_\mu + (1/\alpha_0) \partial_a (\frac{1}{2} \partial^a X_\mu \partial^2 X^\nu \partial^2 X_\nu - 2 \partial^a \partial_b X^\nu \partial^2 X_\nu \partial_b X_\mu - \partial^a \partial^2 X_\mu) \\
&= \sigma_0 \partial^2 X_\mu + (1/\alpha_0) (\partial^2 X_\nu \partial^2 X^\nu \partial^2 X_\mu - 2 \partial_a \partial^2 X^\nu \partial^2 X_\nu \partial^a X_\mu \\
&\quad - 4 \partial^a \partial_b X^\nu \partial_a \partial^b X_\mu \partial^2 X_\nu - 4 \partial^a \partial_b X^\nu \partial_a \partial^2 X_\nu \partial^b X_\mu - 2 \partial^4 X_\mu) = 0.
\end{aligned} \tag{2-9}$$

Furthermore, as a result of the reparametrization invariance, the energy-momentum (EM) tensor defined by

$$T_a^b = -\delta_a^b L + \partial_a X^\mu \frac{\delta L}{\delta \partial_b X^\mu} - \partial_a X^\mu \partial_c \frac{\delta L}{\delta \partial_c \partial_b X^\mu} + \partial_a \partial_c X^\mu \frac{\delta L}{\delta \partial_b \partial_c X^\mu} \tag{2-10}$$

is not only conserved

$$\partial_b T_a^b = 0 \tag{2-11}$$

but also vanishes identically^[28,29]

$$T_a{}^b = 0 \quad , \quad 2-12$$

which in turn means that the EM tensor is traceless

$$T_a{}^a = 0 \quad . \quad 2-13$$

It should be noticed that (2-12) or (2-13) does not necessarily imply conformal invariance here except at the fixed point. In fact, it is shown explicitly in Ref. [27] that there is generically no local residual reparametrization invariance in the equation of motion (2-9). This is not too surprising since conformal symmetry in 2-d quantum field theory is generically a property of massless theory, or of the renormalization group fixed point of massive theory. The Polyakov-Kleinert string is a kind of massive quantum field theory and so is generically not conformal invariant. The conformal invariance is restored only at the fixed point of the model.

There exists a first-order description of the model with the action^[4]

$$S^{(1st)} = \sigma_0 \int d^2\xi \sqrt{g} + \frac{1}{2\alpha_0} \int d^2\xi \{ \sqrt{g} (\Delta X^\mu)^2 + \lambda^{ab} (\partial_a X^\mu \partial_b X^\mu - g_{ab}) \} \quad ,$$

2-14

where g_{ab} is treated as an independent metric field, λ^{ab} is the Lagrange multiplier which enforces the induced metric. Generically, the action (2-14) is not Weyl invariant. It is easy to prove that

the action (2-14) is equivalent to the action (2-1) at the classical level, that is, both lead to the same equations of motion. From

$$\frac{\delta S^{(1st)}}{\delta \lambda^{ab}} = 0, \text{ and } \frac{\delta S^{(1st)}}{\delta g_{ab}} = 0 \quad 2-15$$

we find, respectively,

$$g_{ab} = \partial_a X^\mu \partial_b X^\mu \quad 2-16$$

and

$$\lambda^{ab} = \sigma_0 \alpha_0 \sqrt{g} g^{ab} + \sqrt{g} \left\{ \frac{1}{2} g^{ab} (\Delta X^\mu)^2 - 2 \Delta X^\mu (g^{ac} g^{bd} D_c D_d X^\mu) \right\} , \quad 2-17$$

where we have used the identity

$$\Delta X^\mu \partial_a X^\mu = 0 \quad . \quad 2-18$$

Eqs. (2-16) and (2-17) can be viewed as constraints. The equation of motion can be obtained from

$$\frac{\delta S^{(1st)}}{\delta X^\mu} = 0 \quad , \quad 2-19$$

we find,

$$\frac{1}{\alpha_0} \left\{ \Delta^2 X^\mu - \partial_a (\lambda^{ab} \partial_b X^\mu) \right\} = 0 \quad . \quad 2-20$$

Substituting the constraints (2-16) and (2-17) into (2-20), we recover the equation of motion (2-7).

Though there is generically no local residual reparametrization invariance in (2-9) [27], for a special sector corresponding to minimal surfaces (or string worldsheets), the theory is both Weyl

and conformal invariant classically. To show this, we reconstruct the string worldsheet by means of the collection of its tangent two-planes. In this formulation of the string evolution, the Polyakov-Kleinert string is (classically) equivalent to $G_{2,d}$ ($SO(d)/SO(2) \times SO(d-2)$) σ -model up to certain integrability conditions, expressing the fact that not all collections of two planes are tangent to some two-surfaces^[4]. However, as shown in refs. [22,30], for minimal surfaces, the integrability conditions are trivially satisfied and the Polyakov-Kleinert string action is equivalent to the Kahlerian $G_{2,d}$ σ -model coupled with 2-d gravity which is classically both Weyl and conformal invariant^[30].

In our formalism of X^μ fields, substituting $H^\mu = \Delta X^\mu = 0$ and the expression for the lagrange multiplier (2-17) into the action (2-14) gives an action which is explicitly Weyl and reparametrization invariant. Though this minimal surface action (on-shell) has the same form of Polyakov's bosonic string action^[2], the former is essentially different from the latter. One way to see the difference is by counting the degrees of freedom of the two models. The $G_{2,d}$ σ -model has $2(d-2)$ independent components. The minimal surface action in terms of X^μ field has $2d$ components

with Weyl and reparametrization invariances. This can be seen from the equation of motion (2-7). Substituting $H^\mu = \Delta X^\mu = 0$ into (2-7) gives $\Delta^2 X^\mu = 0$ which has two sets of minimal-surface solutions $\Delta X^\mu_{(1,2)} = 0$. That is, the degrees of freedom of the X^μ fields are doubled for minimal surfaces. Therefore, to get the correct number of degrees of freedom for a minimal surface, four instead of two longitudinal modes have to be removed by gauge fixing procedure. This counting of degrees of freedom agrees also with that in the Hamiltonian formalism of the Polyakov-Kleinert string^[28]. As is well known, Polyakov's bosonic string has only d components with Weyl and conformal invariances classically.

2.2 PISARSKI'S MODEL

We now turn to Pisarski's model^[26], which was proposed by Pisarski as a toy model of quantum gravity with higher derivatives. This is a nonlinear σ model which can also be viewed as a model of a rigid string with a flat metric. The action, given in our notation by

$$S_0 = \frac{1}{2\alpha_0} \int d^2\xi (\partial^2 X^\mu)^2 \quad 2-21$$

is subject to the constraint

$$\partial_a X^\mu \partial_b X^\mu = \delta_{ab} \quad . \quad 2-22$$

By introducing a Lagrange multiplier λ^{ab} , the action can be written as

$$S'_0 = \frac{1}{2\alpha_0} \int d^2\xi \{ (\partial^2 X^\mu)^2 + \lambda^{ab} (\partial_a X^\mu \partial_b X^\mu - \delta_{ab}) \} \quad . \quad 2-23$$

Comparing (2-23) with (2-14), we see that Pisarski's model can formally be obtained from the Polyakov-Kleinert string by assuming

$$g_{ab} = \delta_{ab} \quad . \quad 2-24$$

However, it should be noticed that (2-24) is not a natural or legitimate gauge for the Polyakov-Kleinert string because of the absence of the Weyl invariance of the model as mentioned at the end of Section 2.1. Therefore, these two models are in general not equivalent.

The equation of motion of Pisarski' model is given by^[26]

$$\begin{aligned} & \partial_a \left(\frac{1}{2} \partial^a X_\mu \partial^2 X^\nu \partial^2 X_\nu - 2 \partial^a \partial_b X^\nu \partial^2 X_\nu \partial_b X_\mu - \partial^a \partial^2 X_\mu \right) \\ &= \partial^2 X_\nu \partial^2 X^\nu \partial^2 X_\mu - 2 \partial_a \partial^2 X^\nu \partial^2 X_\nu \partial^a X_\mu \\ & \quad - 4 \partial^a \partial_b X^\nu \partial_a \partial^b X_\mu \partial^2 X_\nu - 4 \partial^a \partial_b X^\nu \partial_a \partial^2 X_\nu \partial^b X_\mu - 2 \partial^4 X_\mu = 0 \quad . \quad 2-25 \end{aligned}$$

Comparing (2-25) with (2-9), we see that the equations agree with

each other up to a σ_0 term. As shown in [27], this equation does not have any local residual reparametrization invariance, which in turn means that Pisarski's model does not have any local invariance. (In Ref. [26], Pisarski claimed that the model has conformal invariance at the classical level. We do not agree.)

We would like to discuss the essential differences between the two rigid strings, although they are equivalent at the classical level, as shown above (the equations of motion coincide up to a σ_0 term). Formally, the difference will show up at the quantum level in the path integral. For the Polyakov-Kleinert string, the conformal anomaly follows from the measure over the metric in the functional integral[14,31], while in Pisarski's model of flat surfaces there is no such conformal anomaly. In more physical language, David and Gitter[17] pointed out that Pisarski's model describes the large distance behavior of elastic membranes, where the strain tensor defined by

$$u_{ab} = \frac{1}{2}(\partial_a X^\mu \partial_b X^\mu - \delta_{ab}) \quad , \quad 2-26$$

vanishes at the classical level. Obviously, the Polyakov-Kleinert string generically does not have such an internal structure.

2.3 RIGID STRING WITH LIQUID-CRYSTAL-LIKE ORDER

Motivated by the elastic-membrane interpretation of Pisarski's model discussed above, we now consider a system with only liquid-crystal-like order. That is, at large distance, only the trace of the strain tensor defined by (2-26) (the "spin-0" part) vanishes, leaving the traceless part (the "spin-2" part) arbitrary. In other words, the system under consideration has a large dilation elastic constant but a zero shear elastic constant. The action is, therefore,

$$S_{L.C.} = \sigma_0 \int d^2\xi \rho_0 + \frac{1}{2\alpha_0} \int d^2\xi \left\{ \frac{1}{\rho_0} (\partial^2 x^\mu)^2 + \lambda (\partial^a x^\mu \partial_a x^\mu - 2\rho_0) \right\} , \quad 2-27$$

where ρ_0 is a ξ -independent trace of the metric which can be viewed as the constant mode of the trace of the metric. (In membranes, such a quantity represents the surface density, number of molecules per area.)

One may wonder that the λ -term in the action (2-27) ensures a fixed trace of the metric which is just a characteristic of a fluid. Liquid crystalline properties imply the presence of an extra vector field with an orientational degree of freedom. Our observation here is that the vector $\partial_a x^\mu$ contained in the strain tensor (2-26)

carries both indices μ and a . In other words, $\partial_a X^\mu$ can be viewed as a vector in either d dimensions (spacetime) or two dimensions (tangential planes of the string world-sheet). Classically or purely geometrically, these are just two equivalent ways to look at the same thing. In other words, the order parameters, the $\partial_a X^\mu$ fields, live in the coset space $SO(d)/SO(2) \times SO(d-2)$ classically. Therefore, as far as the classical action (2-27) considered, the model describes a fluid with fixed density. Quantum mechanically, however, one of the interesting findings in this thesis is that, due to the condensate of the lagrange multiplier, $\partial_a X^\mu$ will live in either the symmetric space $SO(d)$ or $SO(d-2) \times SO(2)$ depending on the temperature. These correspond to two different phase transitions at different temperatures. The tracelessness of the strain tensor means either the orientational isotropy in d dimensions in the high-temperature phase or $O(2) \times SO(d-2)$ symmetry in the low-temperature phase. The phase structure of the model is, in certain aspects, in common with that of liquid crystals. It is in the quantum mechanical sense that we say the model (2-27) to possess a liquid-crystal-like order.

It is important to find out what kind of surfaces (string worldsheets) the action (2-27) describes. Then it is important to note that the action (2-27) can be obtained from that of the

Polyakov-Kleinert string (2-14) by following isotropic ansatz:

$$g_{ab} = \rho_0 \delta_{ab} \quad , \quad 2-28$$

$$\lambda_{ab} = \lambda \sqrt{g} g^{ab} = \lambda \delta^{ab} \quad . \quad 2-29$$

Generically, (2-28) is not a natural or legitimate gauge for the Polyakov-Kleinert string due to the absence of the Weyl invariance (of course, the conformal gauge is always possible because of the reparametrization invariance of (2-14)). Nevertheless, as discussed at the end of Section 2.1, for the minimal surface sector which we concern in this work, the string action (2-14) has conformal and Weyl invariances classically which can be described effectively by a $G_{2,d}$ σ -model. In this case, (2-28) is a legitimate gauge due to the Weyl invariance while (2-29) is just a classical solution of the theory as can be seen by substituting $H^\mu = \Delta x^\mu = 0$ into (2-17).

If we view the $G_{2,d}$ σ -model as an on-shell theory of minimal surfaces (with Weyl and conformal invariances), then the action (2-27) can be regarded as an off-shell generalization of the theory (with Weyl and conformal invariances only at the fixed point). It is the bending energy of the surface, which moves the theory away from the mass-shell or the criticality. (Strictly, since the metric is not yet conformal the first term in (2-27) is not equal to the bending energy. Nevertheless, we expect that this term, in addition

to λ fluctuations, can provide an effective description of the bending energy at the quantum level.) Though it can be viewed as a gauge-fixed form of the Polyakov-Kleinert string action (2-14) for the off-shell generalization of minimal surface sector, we call this model as rigid string with liquid-crystal-like order. The reason is that the minimal surface is completely atypical, while the Polyakov-Kleinert string action (2-14) is a theory of general surfaces. The main reason for us to study the off-shell generalization (2-27) instead of the $G_{2,d}$ σ -model for minimal surfaces is that it is free of tachyon (see Chapter 7). Moreover, it is convenient to study the off-critical behavior of minimal surfaces. In addition, the physical significance of the geometric description is more clear in the action (2-27) than in the $G_{2,d}$ σ -model.

One may wonder if we can choose the usual conformal gauge in the Polyakov-Kleinert model to describe minimal surfaces. To answer this question, we study the classical symmetries possessed by the equation of motion for minimal surfaces. From the action (2-27), we find the equation of motion to be

$$\frac{1}{\alpha_0} \left[\rho_0^{-1} (\partial^2)^2 X^\mu - \partial_a \lambda \partial_a X^\mu - \lambda \partial^2 X^\mu \right] = 0 \quad . \quad 2-30$$

where λ can be read off directly from (2-18) by using (2-28). (The reason for this determination is that the model of minimal surfaces (e.g., (2-27)) can be obtained from the Polyakov-Kleinert model by using (2-28) and (2-29).) We find

$$\lambda = \frac{1}{2} \text{Tr} \lambda_{ab} = \alpha_0 \sigma_0 - \frac{(\partial^2 X^\mu)^2}{2\rho_0^2} \quad . \quad 2-31$$

Using (2-31), we find that Eq. (2-30) contains a nontrivial sector solutions, which solve the following set of equations ("nontrivial" here means that it is not the solution in the trivial Nambu-Goto

limit of $\alpha_0 \rightarrow \infty$):

$$(-\partial^2) X^\mu = 0 \quad , \quad 2-32$$

$$\text{and } \lambda_0 = \alpha_0 \sigma_0 \quad \text{or} \quad \lambda_0 / \alpha_0 = \sigma_0 \quad . \quad 2-33$$

Geometrically, a string world sheet determined by (2-32) and (2-33) is a minimal surface. The equation of motion for minimal surfaces respect the following residual reparametrization invariances:

a) The conformal invariance defined by

$$\xi^a \rightarrow f^a(\xi)$$

with $f^a(\xi)$ satisfying

$$\partial_a f_b + \partial_b f_a - \delta_{ab} \partial_c f_c = 0 \quad . \quad 2-34$$

b) The area-preserving invariance defined by

$$\xi^a \rightarrow f^a(\xi)$$

$$\text{with } f^a(\xi) = \varepsilon^{ab} \partial_b f(\xi) \quad \text{and} \quad \partial^2 f = 0 \quad , \quad 2-35$$

$$\text{satisfying } \partial^a f_a = 0 \quad . \quad 2-36$$

Solutions (2-35) form a group which is known as the area-preserving symmetry group, which exists in the Dirac membrane when the light-cone gauge is chosen [32].

To show the invariance of Eq. (2-32) under the conformal and area-preserving transformations, we consider the general coordinate transformation in two dimension:

$$\xi^a \rightarrow f^a \quad .$$

It is straightforward to show that

$$\begin{bmatrix} \partial_{\xi^1} \\ \partial_{\xi^2} \end{bmatrix} = F \begin{bmatrix} \partial_{f^1} \\ \partial_{f^2} \end{bmatrix} \quad \text{with} \quad F = \begin{bmatrix} \dot{f}_1 & \dot{f}_2 \\ f'_1 & f'_2 \end{bmatrix} \quad 2-37$$

and

$$F^{-1} = \frac{1}{\det F} \begin{bmatrix} f'_2 & -\dot{f}_2 \\ -f'_1 & \dot{f}_1 \end{bmatrix} \quad , \quad 2-38$$

where

$$\dot{f}_a = \partial_{\xi^1} f_a \quad \text{and} \quad f'_a = \partial_{\xi^2} f_a \quad .$$

Then one can show that

$$\partial_{f_1}^2 + \partial_{f_2}^2 = \frac{1}{\det F} (\partial_{\xi^1}^2 + \partial_{\xi^2}^2) \quad 2-39$$

if and only if:

$$(f_2')^2 + (f_1')^2 = (\dot{f}_2)^2 + (\dot{f}_1)^2 \quad \text{and} \quad f_2' \dot{f}_2 = -f_1' \dot{f}_1 \quad . \quad 2-40$$

There exist two sets of solutions of the above equations:

$$\begin{aligned} \text{i)} \quad & \dot{f}_1 = f_2' \quad \text{and} \quad \dot{f}_2 = -f_1' ; \\ \text{ii)} \quad & \dot{f}_1 = -f_2' \quad \text{and} \quad \dot{f}_2 = f_1' \quad . \end{aligned} \quad 2-41$$

Solutions (i) correspond to the conformal transformations determined by (2-34) while solutions (ii) correspond to the area-preserving transformations determined by (2-35) and (2-36). We therefore see that both conformal and the area-preserving transformations leave the Eq. (2-32) invariant. In Chapter 4, we will show that, in a covariant gauge fixing, it is necessary to take into account the area-preserving invariance together with the conformal invariance to remove the unphysical (longitudinal) modes of X-fields. This will bring a new kind of ghost into the theory, in addition to the usual conformal ghosts.

It is important to note that the area-preserving symmetry is irrelevant in the conformal gauge as is the case in Polyakov's bosonic string or the Polyakov-Kleinert string, since the Weyl mode is generically a dynamical quantity there. On the other hand, area-preserving symmetry means a fixed trace of the metric for

minimal surfaces. This is not hard to see. Under general motion including both tangential and normal flows, the dilation of the string worldsheet is given by^[33] $\delta\phi = \nabla^a \delta\xi_a + 2n \cdot H$ (H is the mean curvature). The area-preserving invariance means that $\delta\phi = 2n \cdot H$. For general surfaces, $H \neq 0$ and so that ϕ is generically a dynamical quantity except in the critical dimension. For minimal surfaces, however, $H=0$, which means $\delta\phi=0$. That is, ϕ or the trace of the metric is fixed.

The interesting observation here is that the Polyakov-Kleinert model in the conformal gauge describes the general surfaces (there exist only two longitudinal components of the X^μ fields and the area-preserving invariance is irrelevant), where the trace of the metric or the Weyl mode generically propagates. (Note that in this case the vanishing of the quantity $(g^{ab} \partial_a X^\mu \partial_b X^\mu - \rho)$ does not mean a liquid-crystal-like order.) The model of rigid string with liquid-crystal-like order, on the other hand, describes the off-shell generalization of minimal surfaces, where the area-preserving invariance is of crucial importance.

We now summarize the symmetries of the model at the classical level as far as the minimal surface sector (2-32) is concerned,

including the global rotation and translation symmetries in the imbedding space.

(i) Local symmetries:

(a) The conformal symmetry defined by (2-34);

(b) The area-preserving symmetry defined by (2-35) and (2-36).

(ii) Global symmetries:

(a) Euclidean invariance in the (ξ^1, ξ^2) plane;

(b) the global $O(2)$ rotation invariance of the X^μ field vector .

The associated global $O(2)$ group can be mapped to the center of the area-preserving symmetry group $SU(\infty)$ [32].

(c) Translation invariance of the X^μ -field vector (along the string).

(d) The scaling invariance defined by

$$\xi^a \rightarrow \kappa \xi^a, \quad \rho_0 \rightarrow \frac{\rho_0}{\kappa^2}, \quad \lambda_0 \rightarrow \lambda_0 \quad \text{and} \quad X^\mu \rightarrow X^\mu \quad . \quad 2-42$$

The local symmetries (i-a) and (i-b) are special for the minimal surface sector (2-32). The global symmetry (ii-a) corresponds to conservation of energy and momentum in two dimensions, while those of (ii-b) and (ii-c) are the classical symmetries of the model, since the action (2-27) only contains derivatives of the X-fields.

It is worth mentioning that Eq. (2-33) corresponds to the "freezing" of the Lagrange multiplier at the classical level.

Therefore, it is important to see if these solutions (or the symmetries listed above) are stable against quantum fluctuations. For this purpose, we have to allow the Lagrange multiplier to fluctuate and see if the correlations of these fluctuations are of short range. More precisely, we have to see if it corresponds to a stable fixed point of the theory. The detailed calculation will be given in the next two chapters. The answer is that this is, indeed, so.

Chapter 3

Renormalization of the Bending Rigidity at Zero Temperature

In this chapter, we study the scale dependence of the bending rigidity $1/\alpha_0$ in the present model. The formulation of perturbative renormalization is followed. The purpose of this treatment is twofold: It may serve as a guide for a non-perturbative treatment in Chapter 4. Also the role of quantum fluctuations of the Lagrange multiplier can be seen explicitly in this treatment. Since the temperature dependence of the coupling will not be taken into account in the renormalization, we can view it as renormalization at zero temperature.

3.1 RENORMALIZATION OF THE BENDING RIGIDITY

The renormalization procedure runs parallel to that followed by Polyakov^[4]. Starting from the action (2-35), we first split all fields into slow and fast parts

$$X^\mu = X_0^\mu + X_1^\mu \quad ,$$

$$\lambda = \lambda_0 + i\lambda_1 \quad , \quad 3-1$$

where momenta of fast quantities lie between q_{\max} and q_{\min} . The

factor of i in front of λ_1 is chosen so that integration over λ_1 in

the path integral is over real values (note that $\delta(K) = \int d\lambda e^{i\lambda K}$

where $K=0$ is a constraint). Up to quadratic in fast quantities, we have

$$S_{L.C.} = S_0 + S_{II}^{(a)} + S_{II}^{(b)} \quad , \quad 3-2$$

where S_0 is the action (2-35), which depends on slow fields only

and

$$S_{II}^{(a)} = \frac{1}{2\alpha_0} \int d^2\xi \left\{ \rho_0^{-1} (\partial^2 X_1)^2 + 2i\lambda_1 \partial_a X_0 \partial_a X_1 \right\} \quad ,$$

$$S_{II}^{(b)} = \frac{1}{2\alpha_0} \int d^2\xi \left\{ \lambda_0 \partial_a X_1 \partial_a X_1 \right\} \quad . \quad 3-3$$

The reason for separating $S_{II}^{(a)}$ and $S_{II}^{(b)}$ is that, $S_{II}^{(a)}$ can be

treated as the effective kinetic terms of the fast fields X_1 and λ_1

which determine the propagators of these fields while $S_{II}^{(b)}$ must be

treated as a perturbation (or interaction term among the fast

quantities) of $S_{II}^{(a)}$. To the same accuracy, we can consider the

quantities λ_0 and $\partial_a X_0$ to be ξ -independent in contrast to the fast

quantities. Also, in this approximation, the ghost determinants are

not important, since the unphysical (longitudinal) modes of the X-fields will be removed by the constraint (2-37) in the one-loop approximation (see below). They become important in the nonperturbative calculation in Chapter 4. From $S_{II}^{(a)}$, we can find the propagators of the fast fields X_1 and λ_1 . For this purpose, we add the external source of the X_1 fields to $S_{II}^{(a)}$,

$$S_{II}^{(a)}(J_X^\mu) = \frac{1}{2\alpha_0} \int d^2\xi \left\{ \rho_0^{-1} (\partial^2 X_1^\mu)^2 + 2i\lambda_1 \partial_a X_0^\mu \partial_a X_1^\mu - 2\alpha_0 J_X^\mu X_1^\mu \right\} \quad . \quad 3-4$$

Defining a Green function,

$$\frac{1}{\alpha_0 \rho_0} \partial^4 G^{\mu\nu}(\xi-\xi') = \rho_0 \delta^{\mu\nu} \delta^2(\xi-\xi') \quad , \quad 3-5$$

and translating the X_1 fields,

$$X_1^\mu \rightarrow X_1^\mu + \rho_0^{-1} G^{\mu\nu} J_X^\nu \quad , \quad 3-6$$

we find

$$S_{II}^{(a)}(J_X) = \frac{1}{2\alpha_0} \int d^2\xi \left\{ \rho_0^{-1} (\partial^2 X_1^\mu)^2 - \alpha_0 \rho_0^{-1} J_X^\mu G^{\mu\nu} J_X^\nu \right. \\ \left. + 2i\lambda_1 \partial_a X_0^\mu \partial_a X_1^\mu + 2i\rho_0^{-1} \lambda_1 \partial_a X_0^\mu \partial_a G^{\mu\nu} J_X^\nu \right\} \quad . \quad 3-7$$

Translating the X_1 fields again,

$$X_1^\mu \rightarrow X_1^\mu - i \frac{\partial \lambda_1}{\partial^4} \partial^a X_0^\mu \rho_0 \quad , \quad 3-8$$

where the quantity $1/\partial^4$ should be viewed as a Green function, we find

$$S_{II}^{(a)}(J_X) = \frac{1}{2\alpha_0} \int d^2\xi \left\{ \rho_0^{-1} (\partial^2 X_1^\mu)^2 - \alpha_0 \rho_0^{-1} J_X^\mu G^{\mu\nu} J_X^\nu + \frac{(\partial_a \lambda_1)^2}{\partial^4} \rho_0^2 + 2i \rho_0^{-1} \lambda_1 \partial_a X_0^\mu \partial_a G^{\mu\nu} J_X^\nu \right\} \quad 3-9$$

Translating the λ_1 field

$$\partial_a \lambda_1 \rightarrow \partial_a \lambda_1 + i \rho_0^{-3} \partial_a X_0^\mu \partial_a^4 G^{\mu\nu} J_X^\nu \quad , \quad 3-10$$

we finally obtain

$$S_{II}^{(a)}(J_X^\mu) = \frac{1}{2\alpha_0} \int d^2\xi \left\{ \rho_0^{-1} (\partial^2 X_1^\mu)^2 + \frac{(\partial_a \lambda_1)^2}{\partial^4} \rho_0^2 - \alpha_0 J_X^\mu (\rho_0^{-1} G^{\mu\nu} - \frac{\alpha_0 \partial_a X_0^\mu \partial_a X_0^\nu}{\partial^4}) J_X^\nu \right\} \quad 3-11$$

The path integral is defined by

$$Z(J_X) = \frac{1}{Z_0} \int [dX d\lambda] e^{-S_{L.c.}(J_X)} \quad ,$$

with

$$Z_0 = Z(J_X=0) \quad . \quad 3-12$$

Using (3-11), (3-12) and (3-5), we can easily read off the propagator or the full Green function of the X_1 fields,

$$\begin{aligned}
\langle X_{1\mu}(q) X_{1\nu}(-q) \rangle &= \frac{\delta^2 Z}{\delta J_X^\mu \delta J_X^\nu} \Big|_{J_X=0} \\
&= \frac{\alpha_0 \rho_0}{q^4} (\delta_{\mu\nu} - \rho_0^{-1} \partial_a X_{0\mu} \partial_a X_{0\nu}) \quad , \quad 3-13
\end{aligned}$$

where

$$\delta^{\mu\nu} \rho_0^{-1} \partial_a X_{0\mu} \partial_a X_{0\nu} = 2 \quad \text{and} \quad \delta^{\mu\nu} \delta_{\mu\nu} = d \quad . \quad 3-14$$

From (3-13) and (3-14) we see that the two longitudinal degrees of freedom of the X_1 -field propagator have been removed by the constraint (2-37). This explains why we can neglect the ghost determinant in the one-loop calculation. In the same way as above, we find the λ_1 -field propagator to be

$$\langle \lambda_1(p) \lambda_1(-p) \rangle = \alpha_0 p^2 / \rho_0 \quad . \quad 3-15$$

In (3-13) and (3-15), q and p are momenta carried by X_1 and λ_1 respectively. Substituting (3-13) into $S_{II}^{(b)}$ gives a counterterm W_1 to S_0 :

$$W_1 = \frac{1}{2\alpha_0} \int d^2 \xi \langle \partial_a X_1 \partial_a X_1 \rangle \lambda_0 = \frac{d-2}{4\pi} \ln \frac{q_{\max}}{q_{\min}} \int d^2 \xi \rho_0 \lambda_0 \quad . \quad 3-16$$

We notice that there is no other coupling term of X_0 or λ_0 through

λ_1 in $S_{II}^{(b)}$. As a result, Eq. (3-16) is the only counterterm for our model at least at the one-loop level. This can be traced back to the decoupling of ρ from the curvature fluctuation modes (i.e., the $\rho_0 X^2$ coupling in the rigidity term) by the constant density constraint.

A discussion of the kinetic term of the λ_1 field in (3-11) is now in order: First, it is nothing but a kind of conformal anomaly of the theory at the quantum level. This can be seen by the observation that the λ_1 field has the same dimension as that of the string tension. A scalar field in two dimensions with the dimension of mass squared must be proportional to the scalar curvature of the surface,

$$\lambda_1 \sim R(\xi) \quad . \quad 3-17$$

With the identification (3-17), we immediately see that the kinetic term of the λ field in (3-11) has the same form as the conformal anomaly. Secondly, it is a non-local interaction term representing the internal interactions between distant Gaussian curvatures and implying a long-ranged order in the model. Such an

"anomaly" term arises as a result of quantum fluctuations which force the Lagrange multiplier and, therefore, the density of the string to fluctuate. This term also exists in crystalline membranes and hexatic membranes^[16] as a result of integrating out the in-plane phonon. We shall show in the next section that such an effective non-local interaction term arises at high temperature in the saddle point approximation. Moreover, it is obvious that this anomaly term does not renormalize the bending rigidity at the one-loop level. Finally, we note that the λ_1 term can be localized by the following transformation:

$$\lambda_1 = \partial^2 \phi / \rho_0 \quad , \quad 3-18$$

where ϕ is a real scalar. The Jacobian introduced by the variable transformation (3-18) has the effect of removing two massless longitudinal degrees of freedom of the X-fields. However, in the present one-loop calculation, it can be neglected just as the ghost determinants can, as explained previously. It should be mentioned that the ϕ -field propagator is divergent and needs both ultraviolet and infrared regulators.

Now, we obtain a renormalized action in the form

$$S_{L.C.} = \frac{1}{2\alpha_0} \int d^2\xi \left\{ \rho_0^{-1} (\partial^2 X_0^\mu)^2 + \lambda_0 (\partial_a X_0^\mu \partial_a X_0^\mu - 2\rho_0 (1 - \alpha_0 \frac{d-2}{4\pi} \ln \frac{q_{\max}}{q_{\min}})) \right\} \\ + \sigma_0 \int d^2\xi \rho_0 \quad . \quad 3-19$$

After renormalizing the X_0 fields,

$$X_0 \rightarrow Z^{1/2} X_0 \quad , \quad \lambda_0 \rightarrow \lambda \quad , \quad \rho_0 \rightarrow \rho \quad , \\ Z = 1 - \frac{d-2}{4\pi} \alpha_0 \ln \frac{q_{\max}}{q_{\min}} \quad , \quad 3-20$$

we obtain

$$S_{L.C.}^r = \frac{1}{2\alpha_r} \int d^2\xi \left\{ \rho^{-1} (\partial^2 X^\mu)^2 + \lambda (\partial_a X^\mu \partial_a X^\mu - 2\rho) \right\} \\ + \sigma \int d^2\xi \rho \quad , \quad 3-21$$

with

$$\frac{1}{\alpha_r} = \frac{1}{\alpha_0} - \frac{d-2}{4\pi} \ln \frac{q_{\max}}{q_{\min}} \quad . \quad 3-22$$

The minus sign on the right hand side of (3-22) means asymptotic freedom of the extrinsic coupling in the ultraviolet, which is a desirable property of QCD. In (3-21), we have dropped the subscripts "o" of the λ and X fields. The result (3-22) agrees with that of Refs. [6] [19] and [20].

For the Polyakov-Kleinert string, where ρ is coupled with the curvature fluctuation modes, Polyakov has found^[4], instead of

(3-22),

$$\frac{1}{\alpha_r} = \frac{1}{\alpha_0} - \frac{d}{4\pi} \ln \frac{q_{\max}}{q_{\min}} \quad 3-23$$

The result (3-23) has also been found by a number of authors for the Polyakov-Kleinert string^[5] and the membrane^[10] in the second-order form.

3.2. THE MEANING OF THE X-FIELD RENORMALIZATION

An interesting point, as can be seen from the above derivation, is that only the X_0^μ fields undergo renormalization. The λ_0 field does not. This is different from the rigid string or the membrane without the constraint of constant density, where both X_0^μ and λ_0 fields undergo wave-function renormalization^[4].

We here argue that the X^μ -field renormalization due to quantum fluctuations could be expected for strings or membranes with fixed density or liquid-crystal-like order. (In the Euclidean space, both the rigid string and the membrane have the same form of Hamiltonian. The only difference is the manner of introducing the temperature: In the case of rigid string, the temperature is introduced through periodic Euclidean time (with period $\beta=1/T$),

while in the case of the membrane, temperature is introduced in the usual way through statistics, i.e., $Z = \text{Tr} e^{-\beta H}$. Therefore, the following arguments on membranes can also be applied to string world-sheet.)

As shown by Helfrich [6,34], the deformation of a membrane due to thermal fluctuations makes its average size A' smaller than its true area A :

$$\frac{A}{A'} = \left\langle \frac{1}{n_z} \right\rangle = 1 + \frac{\alpha_0}{4\pi} \ln \frac{q_{\max}}{q_{\min}}, \quad 3-24$$

where $d=3$ has been taken. The average size of the membrane can be calculated from the correlation as

$$A' \xrightarrow{|\xi - \xi'|^2 \sim A \rightarrow \infty} \langle |X(\xi) - X(\xi')|^2 \rangle. \quad 3-25$$

It is clear that A is nothing but the correlation of the undeformed membrane coordinates (the bare fields), while A' is the correlation of the deformed membrane coordinates (renormalized fields). The significance of the X^μ -field renormalization due to thermal fluctuations is that the average size of the membrane is smaller than its true area. (The anomalous dimension of the physical length is then closely related with the Hausdorff dimension of the deformed membrane.)

It is also interesting to note that the renormalization of the extrinsic coupling (3-22) can be put into a form [6,34],

$$\frac{1}{\alpha_r} = \frac{1}{\alpha_0} \frac{1}{A/A'} = \frac{1}{\alpha_0} \frac{\langle |X(\xi) - X(\xi')|^2 \rangle}{|\xi - \xi'|^2} \Big|_{|\xi - \xi'|^2 \sim A \rightarrow \infty} \quad 3-26$$

If only the deformed X^μ fields undergo renormalization, then we see from (3-23) that $1/\alpha_r = (1/\alpha_0)Z$ with Z given by (3-20), which is just Helfrich's result [6, 35]. If both X^μ and λ fields undergo renormalization [4], then (3-26) shows that this is possible only if the true area of the membrane A (or $|\xi - \xi'|^2$) increases under thermal fluctuations. It is now clear that the fact that only the X^μ fields undergo renormalization implies that the true area of the membrane remains unchanged, reflecting the constant density constraint of the membrane.

3.3 PERTURBATIVE RENORMALIZATION GROUP

The result of the computations in Section 3.1. has the following interpretation: We have a theory described by (2-35) with the cut-off Λ_1 (or q_{\max}). If we integrate over the fast quantities X_1 with the wave vectors $\Lambda_2 \leq |q| \leq \Lambda_1$, we obtain the effective action (3-21) which in the low energy limit has again the form (2-35) but with the renormalized coupling (3-22). We therefore conclude that

the physical theory, formulated with the cut-off Λ_1 and the bare coupling, must be equivalent (for small momenta $|q| \ll \Lambda_1$) to one with the cut-off Λ_2 (or q_{\min}) and the specially chosen new coupling described by (3-22). This statement is called renormalizability. The transformation from α_0 to α_r and from Λ_1 to Λ_2 is called renormalization group. In certain regions of momenta, nothing prevents us from repeating the procedure and passing from Λ_2 to $\Lambda_3 < \Lambda_2$ etc.

As shown in ref. [35], renormalizability tells us that in a theory without dimensional parameters, a so-called dimensional transmutation takes place and the renormalized α_r (3-22) can be written in a form:

$$\alpha(q) = \frac{8\pi}{d-2} \frac{1}{\ln(q^2/\lambda)} \quad \text{with} \quad \lambda = \mu^2 \exp - \frac{8\pi}{(d-2)\alpha(\mu)} \quad . \quad 3-27$$

All quantities which depend on $\alpha(q)$ depend on a universal correlation length $\lambda^{-1/2}$. Eq. (3-27) is a true asymptotic expansion for $\alpha(q)$ when $q \gg \lambda^{1/2}$. The β function is easy to calculate. We find

$$\beta(\alpha(q)) = \frac{d\alpha(q)}{d\ln(q/\mu)^2} = -\frac{d-2}{8\pi}\alpha^2(q) \quad , \quad 3-28$$

which only has a zero point (ultraviolet fixed point) at

$$\alpha(q) = 0 \quad \text{and} \quad q = \infty \quad . \quad 3-29$$

However, we should remember that the above renormalizability is only a one-loop approximation and, therefore, is valid only in certain region of momenta. That is, the "arbitrary" scale μ in (3-27) and (3-28) cannot go to zero but only to some (infrared) cut-off Λ . The reason for this cut-off is the existence of a finite width of the string, which is just an idealized description of the color-electric flux tube. Such a finite width is supposed to be inversely proportional to the glueball mass $M_{g.b.}$. At the scale $\Lambda \sim M_{g.b.}$, perturbation theory is no longer applicable.

In the next chapter, using a saddle point approximation in $d > 2$, we will show that the vacuum condensate of the Lagrange multiplier λ_0 has an interpretation as the inverse squared correlation length, similarly to the situation in the nonlinear σ model^[11]. With this relation, we then see from (3-32) that $\lambda_0 = 0$ is compatible with

$\alpha_r=0$. This implies that our classical solutions (2-32) and (2-33), which have the conformal and the area-preserving invariances are stable against quantum fluctuations.

Before ending this chapter, we would like to mention that in the above perturbative renormalizability analysis we have not taken into account the temperature dependence of the bending rigidity. This analysis can, then, only be viewed as a pure quantum-field-theoretical analysis at zero temperature. If the solution (2-32) corresponds to some finite temperature instead of the zero temperature, it then implies a smooth phase below that temperature, which is most desirable. We leave these questions to the next two chapters.

Chapter 4

Generalized Gauge Fixing And The Saddle Point Solutions

In the last chapter, using the perturbative renormalization method, we have shown that the renormalized coupling α_r depends on a persistence length $\lambda^{-1/2}$ (e.g., (3-27)). In this chapter, we show that, in the saddle point approximation, the vacuum condensate of the Lagrange multiplier λ_0 has such an interpretation^[36]. Moreover, it is shown that a finite size (in the "time" direction) effect survives the thermodynamic limit and, as a result, the effective string tension and the saddle point value of λ_0 vanish at a finite critical temperature.

4.1 GENERALIZED GAUGE FIXING

We now consider the action (2-27). As discussed in Section 2.3, this action can be obtained from the Polyakov-Kleinert string action (2-14) by the following scaling gauge:

$$g_{ab} = \rho_0 \delta_{ab} \quad ,$$

4-1

and the isotropic ansatz for the lagrange multiplier (2-29). Here the term "scaling gauge" implies that the scaling invariance (2-42) is respected in this gauge. Only for the (on-shell) minimal surface sector, the gauge (4-1) and the isotropic ansatz (2-29) can be justified.

As discussed in Section 2.3, the theory (2-27) has residual reparametrization invariances in the minimal surface sector. Now it is natural to expect that the residual reparametrization freedom, left after the "gauge" (4-1), is determined by the Killing equation

$$\begin{aligned} \delta g_{ab} &= \nabla_a \delta \xi_b + \nabla_b \delta \xi_a \\ &= g_{ab} \nabla^c \delta \xi_c^{a.p.} + (L \delta \xi^{c \cdot})_{ab} = 0 \end{aligned} \quad , \quad 4-2$$

with

$$(L \delta \xi^{c \cdot})_{ab} = \nabla_a \delta \xi_b + \nabla_b \delta \xi_a - g_{ab} \nabla^c \delta \xi_c \quad , \quad 4-3$$

which determines those transformations that leave the form of the metric tensor (4-1) invariant (isometric mappings). In (4-3), the superscripts "a.p." and "c." on $\delta \xi$'s denote the area-preserving and the conformal transformations respectively. The solutions for

$\nabla^a \delta \xi_a^{a.p.} = \partial^a \delta \xi_a^{a.p.} = 0$ are those given by (2-35) which form a group, the

area-preserving group, while solutions for $(L \delta \xi^{c \cdot})_{ab} = 0$ (i.e., (2-34))

form the conformal group. It is important to note that there will

be no area-preserving invariance, if one choose the usual conformal

gauge. The term $g_{ab} \nabla^c \delta \xi_c$ in (4-2) will be absorbed into the variation of the Weyl variable $g_{ab} \delta \phi$ in that case.

The Jacobian for the variable transformation is defined by

$$[dg] = [d\delta \xi^{a \cdot p} d\delta \xi^c] J(\rho_0) \quad . \quad 4-4$$

Following the standard procedure [37,38], the Jacobian is determined by

$$1 = J(\rho_0) \int [d\delta \xi^{a \cdot p} d\delta \xi^c] \exp - \|\delta g\|^2 / 2 \quad , \quad 4-5$$

where

$$\begin{aligned} \|\delta g\|^2 &= \int d^2 \xi \sqrt{g} (g^{ac} g^{bd} + C g^{ab} g^{cd}) \delta g_{ab} \delta g_{cd} \\ &= \int d^2 \xi \rho_0 (\nabla^c \delta \xi_c^{a \cdot p})^2 (2 + 4C) + (L \delta \xi^c, L \delta \xi^c) \quad , \end{aligned} \quad 4-6$$

and we find

$$J(\rho_0) = \det'^{1/2} (-\delta_{ab} \Delta) \det'^{1/2} (L^+ L) \quad , \quad 4-7$$

where

$$(L^+ L \delta \xi^c)_a = -\nabla^b (\nabla_a \delta \xi_b + \nabla_b \delta \xi_a - g_{ab} \nabla^c \delta \xi_c) \quad . \quad 4-8$$

The primes on the determinants omit the zero modes. With the Jacobian given by (4-7), not only the usual conformal ghosts and antighosts [2] but also a pair of new complex scalar ghost and antighost associated with the gauge fixing of the area-preserving symmetry, called imbedding ghost in ref. [39], arise in the theory.

The action for the imbedding ghost can be determined by

$$\det'(-\Delta) = \int [de^* de] \exp \left\{ \int \frac{d^2\xi}{2\pi} \partial^a e^* \partial_a e \right\} \quad . \quad 4-9$$

From (4-8), we compute:

$$\begin{aligned} (L^+ L \delta \xi^c)_a &= -\nabla^b (\nabla_a \delta \xi_b + \nabla_b \delta \xi_a - g_{ab} \nabla^c \delta \xi_c) \\ &= -\nabla^2 \delta \xi_a - [\nabla^b, \nabla_a] \delta \xi_b \\ &= -(\Delta + \frac{1}{2} R_o) \delta \xi_a \quad . \end{aligned} \quad 4-10$$

To remove the unphysical components of the X^μ fields, we find

$$\lambda_o = -R_o/2 \quad , \quad 4-11$$

where λ_o is the vacuum condensate of the Lagrange multiplier. For the flat metric (2-28), $R_o=0$. We will see below that at the critical point, $\lambda_o=0$. That is, Eq. (4-11) holds at the critical point. We assume that (4-11) holds even at off-critical points in the gauge fixing procedure. We call the gauge fixing procedure stated above a generalized gauge fixing procedure, which can be justified only at the fixed point. At points away from the fixed point, the theory is neither conformal nor Weyl invariant and so no gauge fixing is really needed. The unphysical modes contained in the theory can only be removed by other reason. This

may be a generic problem associated with any off-shell theory and explains why in ref. [16] a noncovariant description is adopted, in which only physical (transverse) modes are contained in the bending energy term (Eq. (4) of ref. [16]). In our covariant description, the unphysical modes are to be removed by the generalized gauge fixing procedure stated above. The physical ground for the generalized gauge fixing procedure is that the unphysical degrees of freedom (the longitudinal modes of the X^μ fields for instance) should not contribute even away from the fixed point.

An alternative but much simpler treatment of the model is to consider an action which has the same form of (2-27) but only contains transverse components for X fields. This is precisely an nonlinear σ -model. No gauge fixing is needed in this case. The shortcoming of this simple σ -model description is that it is only suitable for string worldsheets with trivial topology (a plane or a sphere). On the other hand, the description adopted in this Chapter can be easily extended to the case of a torus (see Chapter 7).

4.2 SADDLE POINT SOLUTIONS [36]

The path integral is defined as follows

$$Z = \int \frac{[dg dX d\lambda]}{V} \exp -S_{L.C.}(X, \lambda, \rho_0) \quad , \quad 4-12$$

where V is volume of the residual reparametrization group and $S_{L.C.}$ is given by (2-27). Using the integral measure over the metric defined by (4-4) and the Jacobian given by (4-7) and (4-11), the integral over the group space cancels the group volume V and gives

$$Z = \int [dx d\lambda] J(\rho_0) \exp - S_{L.C.}(X, \lambda, \rho_0) \quad . \quad 4-13$$

In order to continue the calculation we have to conjecture (and check it in the next section) that the correlation length of the Lagrange multiplier λ is small in comparison with the size of our region. If this is true, λ can be replaced by their mean values (the saddle point approximation).

The integral over X^μ is then Gaussian and can be performed in a standard fashion. We find,

$$Z \sim \exp - S_{\text{eff.}}(\rho_0, \lambda_0) \quad , \quad 4-14$$

where

$$S_{\text{eff.}} = \frac{d-2}{2} \ln \det ' [\Delta^2 - \lambda_0 \Delta] + \left(\sigma_0 - \frac{\lambda_0}{\alpha_0} \right) \int d^2 \xi \rho_0 \quad , \quad 4-15$$

and

$$\Delta = \rho_0^{-1} \partial^2 \quad .$$

From (4-15), we immediately see that all the longitudinal modes are removed by the gauge fixing procedure. We now have to solve a set of saddle point equations corresponding to the changes of λ_0 and A

(the area of the string sheet):

$$\frac{\delta S_{\text{eff.}}}{\delta \lambda_0} = 0 \quad , \quad 4-16$$

and

$$\frac{\delta S_{\text{eff.}}}{\delta A} = 0 \quad . \quad 4-17$$

With the effective action (4-15), Eq. (4-16) becomes

$$\begin{aligned} \frac{\rho_0}{\alpha_0} &= \frac{d-2}{2} \frac{\delta}{\delta \lambda_0} \ln \det' [(-\partial^2/\rho_0)^2 - \lambda \partial^2/\rho_0] \\ &= \frac{d-2}{2} G(\xi, \xi, \lambda_0) \quad . \end{aligned} \quad 4-18$$

Here we have introduced the Green function,

$$G(\xi, \xi', \lambda_0) = \langle \xi' | \frac{-\partial^2/\rho_0}{(-\partial^2/\rho_0)^2 - \lambda \partial^2/\rho_0} | \xi \rangle \quad . \quad 4-19$$

Let us now solve the equation (4-18). In the momentum representation, we have ($p'^2 = p^2/\rho_0 = -\partial^2/\rho_0$)

$$G(\xi, \xi', \lambda_0) = \rho_0 \int \frac{d^2 p'}{(2\pi)^2} \frac{e^{i p' \cdot (\xi - \xi') \sqrt{\rho_0}}}{p'^2 + \lambda_0} \quad , \quad 4-20$$

and therefore (4-18) becomes,

$$1 = \frac{(d-2)\alpha_0}{2} \int \frac{d^2 p'}{(2\pi)^2} \frac{1}{p'^2 + \lambda_0} = \frac{(d-2)\alpha_0}{8\pi} \ln \frac{\Lambda^2}{\lambda_0} \quad . \quad 4-21$$

Solving for λ_0 from (4-21), we find

$$\lambda_0^* = \Lambda^2 \exp(-8\pi/(d-2)\alpha_0) \quad \text{or} \quad \alpha_0(\Lambda) = 8\pi/(d-2) \ln \Lambda^2 / \lambda_0^* \quad , \quad 4-22$$

where Λ is the renormalization scale. As discussed in Section 3.3, there exists a momentum scale $\Lambda \sim M_{g,b}$ at which perturbation theory breaks down. On the other hand, the coupling α is dimensionless and asymptotically free. So a dimensional transmutation occurs: the dimensionless α and a dimensionful scale Λ can be traded for each other. Since the theory requires renormalization, one must specify the renormalization scale Λ at which the renormalized $\alpha(\Lambda)$ is prescribed. We choose $\Lambda \sim M_{g,b}$ as the renormalization scale to specify α .

Comparing (4-22) with (3-27) we find that the vacuum condensate of λ_0 has the interpretation of the persistent length. A discussion of Eq. (4-22) is now in order. Though Eqs. (4-22) and (3-27) share the same property of asymptotic freedom, their interpretations are quite different. First, Eq. (3-32) represents a running charge with explicit scale or momentum dependence while Eq. (4-22) is the "fixed

charge" (The scale has been fixed to be Λ) which has implicit temperature dependence. The temperature dependence arises from the vacuum condensate of λ_0 (see below). One might wonder if the fixed scale charge (4-22) is consistent with the asymptotic freedom.

Indeed, this property will show up as the vacuum condensate λ_0

tends to zero which formally corresponds to keeping λ_0 to be some

finite value and letting the scale Λ increase to infinity just as

the running charge (3-27). However, the physical meaning is quite

different. Loosely speaking, in (3-27), we fixed the temperature

(to zero) and considered the scale or momentum dependence of the

running charge while in (4-22), we did the opposite: to fix the

scale Λ and look at the temperature dependence of the fixed charge.

Secondly, Eq. (3-27) is obtained from a perturbative expansion,

while Eq. (4-22) is nonperturbative in nature at all temperatures.

The third, the vacuum condensate λ_0 depends on the temperature (see

below). That is, the persistence length of the present model is

temperature dependent in certain region, reflecting an unusual phase structure of the system under consideration.

To solve Eq. (4-17) we note that in the effective action (4-15),

$$\frac{d-2}{2} \ln \det'(\Delta^2 - \lambda_0 \Delta) = \frac{d-2}{2} \text{Tr}' \ln(-\Delta) + \frac{d-2}{2} \text{Tr}' \ln(-\Delta + \lambda_0) \quad , \quad 4-23$$

Using a ζ -function regularization method^[40,41], we find the first term on the right hand side (RHS) of (4-23) to be

$$((d-2)/2) \ln \det'(-\Delta) = -\rho_0(d-2)\pi/6 \quad , \quad 4-24$$

where we have set $R' \gg \beta'$ and $R' = \rho_0 \beta'$ and the sheet C is defined by

$$C = \{ (\xi^1, \xi^2) \mid 0 \leq \xi^1 \leq R' \} / \sim \quad , \quad 4-25$$

where the symbol \sim represents the equivalence relation (or the periodicity in the intrinsic "time" ξ^2) defined by

$$(\xi^1, \xi^2) \sim (\xi^1, 2\beta' + \xi^2) \quad . \quad 4-26$$

Similarly, we calculate the second term on the r.h.s. of (4-23) and find

$$\frac{d-2}{2} \ln \det'(-\Delta + \lambda_0) = (d-2)\rho_0\pi I(a) + \frac{(d-2)\rho_0 a^2}{8\pi} (1 + \ln \frac{\Lambda^2}{\lambda_0}) \quad , \quad 4-27$$

where

$$\begin{aligned} I(a) &= 4 \int_0^\infty \frac{dy}{1 - e^{-2\pi(y+a/2\pi)}} y^{1/2} (y + a/\pi)^{1/2} \\ &= -\frac{a}{\pi^2} \sum_{n=1}^\infty \frac{1}{n} K_1(na) \quad , \end{aligned} \quad 4-28$$

and $a^2 = \lambda_0 \beta^2$. 4-29

Here $K_1(na)$ is the modified Bessel function and $I(a)$ has the limiting values

$$I(a) = \begin{cases} -1/6 & \text{as } a \rightarrow 0 \\ 0 & \text{as } a \rightarrow \infty \end{cases} . \quad 4-30$$

In (4-29), $\beta = 1/T$ (T denotes the physical temperature) is defined by

$$A_{\text{int}} = \int d^2 \xi = 2R' \beta' = 2\beta^2 \quad , \quad 4-31$$

where A_{int} measures the intrinsic size of the string world-sheet which differs from the "external" area of the sheet A :

$$A = \int \rho_0 d^2 \xi = 2R\beta = 2\rho_0 \beta^2 \quad . \quad 4-32$$

The reason for distinguishing between A and A_{int} is that the operators involved (e.g. (4-15) or (4-23)) contain a factor ρ_0^{-1} and so the real frequencies or momenta depend on β instead of β' (e.g., (4-15)).

Gathering all these pieces gives

$$S_{\text{eff.}} = \sigma_{\text{eff.}} \rho_0 \beta^2 + (\text{terms irrelevant as } \rho_0 \rightarrow \infty) \quad , \quad 4-33$$

where

$$\sigma_{\text{eff.}} = \sigma_0 - \frac{\lambda_0}{\alpha_0} + \frac{(d-2)\lambda_0}{8\pi} \left(1 + \ln \frac{\Lambda^2}{\lambda_0}\right) - \frac{(d-2)\pi}{6\beta^2} (1 - 6I(a)) \quad , \quad 4-34$$

which is the effective string tension defined by

$$\sigma_{\text{eff}} = -\lim_{A \rightarrow \infty} \frac{1}{A} \ln Z \quad . \quad 4-35$$

Here Z is the path integral defined by (4-14).

It is worth mentioning that the last term in (4-34), the β -dependent term is reminiscent of the Luscher term in the static potential [13,24,41-43] and is a characteristic feature of QCD string model arising from the zero-point transverse oscillations of the stretched string. One might wonder whether such a term arises because of the finite size (in the "time" direction) and may be absent in the thermodynamic limit. However, in the present model, by distinguishing A and A_{int} (e.g., (4-31) and (4-32)), such a term does survive the thermodynamic limit and should not be overlooked. In fact, in the present model, this is the only term which decreases the string tension (see (4-34) and also below) and so is of crucial importance in reducing the effective string tension to zero at the critical point (see also Chapter 5).

It should be mentioned that the "finite size" (here in the "time" direction) effect which survives the thermodynamic limit is by no means unique to the present model but exists in many other models. In the context of QCD strings, one is often concerned two

different limit behaviors of strings corresponding to two limit shapes of the string worldsheet : $R \gg \beta$ [13,36] and $\beta \gg R$ [24,41-43].

In either case, the weight function ρ_0 is effectively fixed to be infinity. As a result, the finite size effect, either the $1/\beta$ term [13,36] or the $1/R$ term [24,41-43], survives the thermodynamic limit. In the case of membranes, it is not inconceivable that the thermodynamic limit corresponds to the limit case of infinite surface density (number of molecules per area). In this case, the finite size effect, the $1/R$ term, survives the thermodynamic limit.

Using (4-33), the saddle point equation (4-17) reduces to

$$\sigma_{\text{eff.}} = 0 \quad . \quad \quad \quad 4-36$$

We thus see that the value of ρ_0 is not determined by the saddle point equation (4-17) which is merely a result of the global scaling invariance (2-42) of the theory.

Results similar to (4-34) have also been found by Pisarski [31], David and Gitter [14] for the Polyakov-Kleinert string and rigid random surfaces. In the equations (2-9) of Ref. [31] and (2-23) of Ref. [14], the β -dependent term, the last term on the RHS of (4-34), was absent. That is, the zero-point energy term does not survive the thermodynamic limit in those models. This is not

surprising since those are models of general surfaces. The global scaling invariance (2-42) is only an artifact of some special gauge^[44], such as the scaling gauge (4-1), instead of a true symmetry as in the present model. Therefore, in the saddle point approximation in the large d limit, one is allowed to choose some physical gauge to break the global scaling symmetry^[14]. As a result, ρ_0 is determined as a saddle point solution^[14] instead of treating it as arbitrary as in the present model. Therefore, in the thermodynamic limit in those models both A and A_{int} must be taken to be infinity since ρ_0 is just a determined value there. This explains why no finite size effect can survive in the thermodynamic limit in those models of general surfaces. Therefore, the real reason for us to distinguish between A and A_{int} is the global scaling invariance (2-42) which forces the density ρ_0 to be undetermined. That is, though the area A of the string sheet is supposed to be fixed, the ratio of the two lengths in the spatial and "time" directions must left arbitrary if the global symmetry is unbroken. Or in other words, ρ_0 is a free parameter (not a dynamical quantity) in the present model due to the scaling

invariance (2-42). As a result, in the thermodynamic limit, $A \rightarrow \infty$, while A_{int} or β remains finite. (In this and the next chapter, we only consider the limit case $R \gg \beta$, that is, $\rho_0 \rightarrow \infty$. In Chapters 6, 7 and 8, a more general case will be considered.)

Though Eq. (4-17) or (4-36) does not determine the value of ρ_0 in the present model, it, when combined with (4-22), determines the value of λ_0 . The solution of (4-36) is

$$\alpha_0^* = \frac{8\pi}{d-2} \frac{1}{\ln \Lambda^2 / \lambda_0} \quad , \quad 4-37$$

and

$$\lambda_0^* = -\frac{8\pi\sigma_0}{d-2} + \frac{4\pi^2}{3\beta^2} (1 - 6I(a)) \quad . \quad 4-38$$

Comparing Eq. (4-37) with the result (3-27) shows that the vacuum condensate of the Lagrange multiplier has the interpretation of the inverse squared correlation length. One remarkable result of the saddle point solution (4-38) is that λ_0 vanishes at certain finite critical temperature which corresponds to the fixed point of the theory: $\beta(\alpha(\lambda_0)) = d\alpha(\lambda_0)/d\ln(\Lambda^2/\lambda_0) \sim -\alpha^2(\lambda_0) = 0$ at $\lambda_0 = 0$. Obviously, this critical point corresponds to the minimal surface or in other

words, the minimal surface sector dominates at the fixed point.

Substituting (4-37) into (4-34) gives

$$\sigma_{\text{eff.}} = \sigma_0 + \frac{(d-2)\lambda_0}{8\pi} - \frac{(d-2)\pi}{6\beta^2} (1 - 6I(a)) \quad . \quad 4-39$$

We see from (4-39) that the β -dependent term represents the effect of thermal fluctuations which tends to lower the string tension. On the other hand, the condensate of the Lagrange multiplier λ_0 serves as a dynamically generated string tension to control the fluctuations.

4.3 ON THE FREEZING OF λ

In this section, we check whether our conjecture concerning the "freezing" of the lagrange multiplier is correct, i.e., to check if the λ -field fluctuations are of short range and so do not destroy the long-ranged order in the low-temperature region. In the action (2-27), we set

$$\lambda(\xi) = \lambda_0 + i\eta(\xi) \quad . \quad 4-40$$

We can find the quadratic term in the induced action for the η field to be

$$S_{II}(\eta) = \frac{1}{2} \int \frac{d^2 q}{(2\pi)^2} \eta(q) \eta(-q) B(1/q^2) \quad , \quad 4-41$$

where

$$B(1/q^2) = - \int_k^{k+q} \quad , \quad 4-42$$

$$= \frac{d-2}{2} \int \frac{d^2 k}{(2\pi)^2} \frac{(k \cdot (k+q))^2}{(k^4 + \lambda_0 k^2) ((k+q)^4 + \lambda_0 (k+q)^2)}$$

Here we have accounted for the fact that η interacts with X fields through the Lagrangian:

$$L_{int} = \frac{i}{2\alpha_r} \int d^2 \xi \eta(\xi) (\partial_a X)^2 \quad , \quad 4-43$$

and the fact that the X-field propagator is given by

$$\langle X_i(k) X_j(-k) \rangle = \frac{\alpha_r}{k^4 + \lambda_0 k^2} \delta_{ij} \quad , \quad 4-44$$

where we have taken into account the ghost contributions and i, j are normal indices. A straightforward estimate of (4-42) gives in

the limit $\lambda_0 \rightarrow 0$,

$$B(1/q^2) = \frac{c \ln q / \Lambda_{min}}{q^2} (1 + O(\frac{\Lambda_{min}}{q})) \quad , \quad 4-45$$

where $c = (d-2)/4\pi$. For nonvanishing c (i.e., $d > 2$) in (4-45),

substituting (4-45) into (4-41), we find that the correlation function (or the amplitude of fluctuations) for the η -field is of the order of $(A_{\text{int}}^2 \ln q / \Lambda_{\text{min}})^{-1}$, where A_{int} is the intrinsic size of our object. Therefore, in the case $c \neq 0$ we can neglect the influence of η -fluctuations since Λ_{min} can be consistently set to zero.

We here emphasize that the above derivation relies on the fact that λ_0 vanishes at a finite temperature. This means that our conjecture that the λ field can be treated as a mean field in the last section is justified as λ_0 is close to zero. In other words, our saddle point approximation becomes a very good one in any dimension $d > 2$ at low temperature where $\lambda_0 \rightarrow 0$. This differs from the situation of the Polyakov-Kleinert string as well as Pisarski's model where the saddle-point approximation is a good one only in the infinite d limit since λ_0 never goes to zero.

At high temperature, on the other hand, where λ_0 is finite and serves as a natural infrared cut-off of our theory, the correlation

length of the η field is the same order as the size of our object.

In this case, the quantum fluctuations of the λ field enter the theory. As a result, a "conformal anomaly" is generated dynamically:

$$(\text{Anomaly}) = \frac{1}{2\alpha_r} \int d^2\xi \eta \frac{1}{-\Delta} \eta \quad , \quad 4-46$$

where we have used $c=(d-2)/4\pi$ and the logarithmic factor in (4-45) has been absorbed into the definition of the renormalized coupling

α_r :

$$\alpha_r = \frac{8\pi}{d-2} \frac{1}{\ln q^2/\lambda_0} \quad . \quad 4-47$$

Eq. (4-46) can be regarded as an effective non-local interaction term, representing the effective interactions between distant Gaussian curvatures and manifesting a long-range order in the model. The importance of the anomaly term will be discussed in Chapter 8 as the string susceptibility is calculated.

Chapter 5

Smooth-Rough Transition

In this chapter, we discuss the finite temperature transition of the model. It is shown that the saddle point solutions obtained in the last chapter imply a smooth-rough transition in the present model. The Hausdorff dimension of the string worldsheet and the width of the string are calculated.

5.1 THE HAUSDORFF DIMENSION THE WIDTH OF THE STRING

Eq.(4-38) for the dynamically generated string tension or the saddle point solution of the Lagrange multiplier λ_0^* is reminiscent of the situation in the Ising model^[45] and must be solved numerically to determine the critical temperature. However, it is easy to see that there is always one solution, by using the limiting value of $I(a)$ in (4-30), if

$$T \geq T_c = \sqrt{\frac{3\sigma_0}{\pi(d-2)}} \quad . \quad 5-1$$

As $T \rightarrow T_c$ from above, λ_0^* decreases and we may obtain its asymptotic dependence by using the limiting value of $I(a)$ in

(4-30), that is,

$$\lambda_o^* = -\frac{\sigma_o 8\pi}{d-2} + \frac{8\pi^2}{3\beta^2} \quad . \quad 5-2$$

We see from (5-2) that λ_o^* approaches zero as T approaches T_c from above, and vanishes asymptotically as

$$\lambda_o^* \sim \left(1 - \frac{T_c^2}{T^2}\right)^{\nu=1} \quad . \quad 5-3$$

We note that $\partial\lambda_o^*/\partial\beta|_{\beta\rightarrow\beta_c} = -2\pi^2/3\beta_c^3 < 0$, but λ_o^* cannot be negative since it is the inverse squared persistence length as can be seen from (4-37). We conclude that λ_o^* remains zero at or below the critical temperature T_c .

It is interesting to compare the critical temperature (5-1) for the present model with that obtained in refs. [13] for the Nambu-Goto string and [12] and [46] for the Polyakov-Kleinert string. We find that the critical temperatures coincide numerically even though the associated systems are generally different. In fact, we will see soon that the features of the transitions associated with these critical temperatures are very different.

The exponent for the power law behavior of the λ_o^* in (5-3) is

given the symbol $\nu=2/d_H$ according to Polyakov[35]

$$\lambda_o^* \sim \left(1 - \frac{\sigma_{o\ cr}}{\sigma}\right)^{\nu=2/d_H} \quad , \quad 5-4$$

with $\sigma = (d-2)\pi T^2/3$ and $\sigma_{o\ cr} = \sigma_o = (d-2)\pi T_{cl}^2/3$. Here d_H is the Hausdorff (or fractal) dimension. Comparing (5-4) with (5-3) gives $d_H = 2$, that is, for rigid string with liquid-crystal-like order, the Hausdorff dimension equals its topological dimension at or below the critical temperature.

To confirm our conclusion on the Hausdorff dimension which determines the fine structure of the string (or string worldsheet), we compute the mean squared distance between any two points on the sheet. Using the propagator of the X-fields (4-44), we find,

$$\langle |X(\xi) - X(\xi')|^2 \rangle = (d-2)\alpha_o \int \frac{d^2 k}{(2\pi)^2} \frac{(2-2e^{i\mathbf{k}\cdot(\xi-\xi')})}{k^2(k^2+\lambda_o)} \quad . \quad 5-5$$

Decomposing the propagator in the momentum space as follows

$$\frac{1}{k^2(k^2+\lambda_o)} = \frac{1}{\lambda_o k^2} - \frac{1}{\lambda_o(k^2+\lambda_o)} \quad , \quad 5-6$$

substituting (5-6) into (5-5) and noticing the cancellation between the massless modes, we find,

$$\langle |X(\xi) - X(\xi')|^2 \rangle = \frac{(d-2)\alpha_o}{\pi\lambda_o} (\ln(\sqrt{\lambda_o}|\xi-\xi'|) + K_o(\sqrt{\lambda_o}|\xi-\xi'|)) \quad . \quad 5-7$$

For $|\xi-\xi'| \ll \lambda_0^{-1/2}$, that is, for $\lambda_0 \rightarrow 0$, there is a cancellation between the Bessel function and the logarithm. The leading behavior is

$$\begin{aligned} \langle |X(\xi) - X(\xi')|^2 \rangle &\underset{\lambda_0 \rightarrow 0}{\sim} - \frac{(d-2)\alpha_0}{4\pi} |\xi-\xi'|^2 \ln(\sqrt{\lambda_0} |\xi-\xi'|) + \text{const.} \\ &\sim |\xi-\xi'|^2, \end{aligned} \quad 5-8$$

where we have used the renormalized coupling (4-37) to cancel the logarithmic factor and have omitted a constant term for large $|\xi-\xi'|$. Eq. (5-8) means that the Hausdorff dimension of the sheet is two which confirms our previous calculation. On the other hand, for $|\xi-\xi'| \gg \lambda_0^{-1/2}$, the Bessel function decays exponentially, so the leading behavior is

$$\langle |X(\xi) - X(\xi')|^2 \rangle \underset{|\xi-\xi'| \gg \lambda_0^{-1/2}}{\sim} \frac{(d-2)\alpha_0}{\pi\lambda_0} \ln(\sqrt{\lambda_0} |\xi-\xi'|) \quad . \quad 5-9$$

The logarithm in (5-9) cannot be removed by the renormalized coupling because the ratio λ_0/α_0 in (5-9) is (almost) fixed as both λ_0 and α_0 change (see Eq. (6-15) below). Eq. (5-9) means that the string worldsheet is crumpled for $|\xi-\xi'| \gg \lambda_0^{-1/2}$ with the Hausdorff dimension infinity. This is the typical behavior of the

Nambu-Goto string^[47]. We thus see that in the region where λ_0 becomes large the model goes to the Nambu-Goto limit. There also exists another Hausdorff dimension of string sheets in the literature, $d_H=4$ [13,42,48]. This value can also be obtained from the present model. In the intermediate region, the sheet is expected to be rough. Though the calculation of the Hausdorff dimension in this intermediate region is highly non-trivial, we can get some hint from the expression of the effective string tension (4-39). On very general grounds^[24,49], the coefficient of the $1/\beta$ term is expected to be universal. In other words, various universality classes of strings should in general be distinguished by different universal coefficients of the $1/\beta$ term, i.e., the coefficient $(d-2)(1-6I(a))/2$. Obviously, in this coefficient, $(d-2)$ is just the number of the independent degrees of freedom of the X-fields. What is the meaning of the quantity $(1-6I(a))/2$ then? We conjecture that the quantity $(1-6I(a))/2$ may be identified with the critical exponent of the present model in the intermediate region:

$$v = (1-6I(a))/2 = 2/d_H \quad . \quad 5-10$$

From the asymptotic behavior of the function $I(a)$ of (4-30), we immediately see that,

$$1/2 \leq \nu \leq 1 \quad \text{and} \quad 2 \leq d_H \leq 4 \quad .$$

5-11

5.2 THE WIDTH OF THE STRING

We now show that the critical temperature (5-1) associates with a second-order smooth-rough transition. To prove this we need to calculate mean fluctuations $\langle u_q \rangle$ of the string world-sheet from a reference plane, say the (ξ^1, ξ^2) -plane, near the transition. This issue had been studied more than a decade ago by Helfrich^[34]. The result is, in terms of our notation,

$$\langle |u_q|^2 \rangle = \frac{\alpha_r}{A_{\text{int}}(q^4 + \lambda_0 q^2)} \quad \text{with} \quad q = \frac{2\pi}{\beta} \quad . \quad 5-12$$

In the regime of temperature $T \leq T_c$, $\lambda_0 = 0$, and therefore,

$\alpha_0 = 0$ (e.g. (4-37)). We thus have $\langle |u_q|^2 \rangle = 0$ for $T \leq T_{c1}$ which means

that the string is smooth for $T \leq T_{c1}$. (We recall $d_H(T \leq T_c) = 2$.)

In the regime of temperature $T > T_c$ and $0 < \lambda_0 < 1/\beta^2$, we have $\alpha_0 > 0$ and so that

$$\langle |u_q|^2 \rangle \sim \frac{\beta^2}{(2\pi)^4 (1 + \lambda_0 \beta^2 / (2\pi)^2)} \sim \beta^2 \quad . \quad 5-13$$

Eq. (5-13) means that the string is rough for $T > T_c$ and $0 < \lambda_0 < 1/\beta^2$.

From above analysis, we see that λ_0 plays a role of an order parameter in the present model: it vanishes at T_c and remains zero below T_c , and the system is in the global $O(d-2) \times O(2)$ (and also translation) symmetric phase since the string worldsheet is essentially smooth ($\langle |u_q|^2 \rangle = 0$) with the Hausdorff dimension two.

Above the critical temperature, on the other hand, λ_0 increases and becomes finite. In this region the global $O(d-2) \times O(2)$ (and also the translation) symmetry(ies) is (are) broken and the system is in the rough phase ($\langle |u_q|^2 \rangle \sim A_{int}$) with the Hausdorff dimension larger than two. We thus see that there is a smooth-rough transition associated with the critical temperature T_c (5-1). This is a second-order transition since the persistence length ($1/\lambda_0$) is infinite at the transition. Although a critical temperature with the same value of (5-1) was obtained in Refs. [13] and [46], it does not associate with a smooth-rough transition since the smooth

phase was absent there.

It should be noticed that this smooth-rough transition differs from the well-known roughening transition, which exists in the "solid-on-solid" model^[50] as well as the Z_2 lattice gauge theory^[51] and also other related models, though both share some properties. In those models, a roughening transition is accompanied by a non-analyticity of various quantities, including the surface tension, as a function of the temperature (or the gauge coupling in the case of lattice gauge theories). Moreover, the transition is of infinite order. In our case, on the other hand, the smooth-rough transition is accompanied by the vanishing effective string tension and is of second order.

This should not be too surprising since those models^[50,51] are quite different in nature from the present model. Among the differences we would like to emphasize the following: First, in the present model, the transition is related with the breakdown of the continuous global symmetries (the $O(2)$ and translation invariances) while in other models it is associated with the breakdown of discrete translation symmetry. Secondly, in the present model, the transition is driven by the Higgs-like mechanism due to the effective long ranged interaction introduced by the internal liquid-crystal-like order (see below), while in other models^[50,51] it is driven by the Kosterlitz-Thouless mechanism. (There is an

effective U(1) symmetry in the intermediate region in other models[50].)

Let us now look at the Higgs particles of our model living in the rough phase. Associated with the breakdown of the translation invariance in 2 (or d-2) dimensions, there is a dynamically generated mass $m^2=\lambda_0$. Correspondingly, there exist (d-2) massive modes of the X-fields as can be seen from the Green function of these modes (4-20). These are the Higgs particles associated with the translation symmetry breakdown. Furthermore, associated with the global O(2) symmetry breaking, there is an anomaly (4-46) which is non-local. To make it local, we make a variable transformation similar to (3-18):

$$\eta \rightarrow \partial^2 \phi \quad . \quad 5-14$$

Using (5-14), the anomaly (4-46) becomes

$$(\text{Anomaly}) \sim \frac{1}{2\alpha_r} \int d^2 \xi \partial^a \phi \partial_a \phi \quad . \quad 5-15$$

At first sight, one might wonder whether this massless mode may destroy the long-range order of the system. However, this is not the case since the field ϕ in (5-15) will be "frozen" at or below the critical temperature T_c where $\alpha_r=0$ according to (4-47) and (4-38). All these properties are due to the liquid-crystal-like

order, which forces the trace of the metric to be fixed, induces an effective long-range interaction (4-46) into the theory, and so makes the Mermin-Wagner-Coleman theorem^[25] not applicable for the present model.

Chapter 6

A Simple Estimate of the Hagedorn Transition

In this chapter, we make a simple estimate of the Hagedorn transition for the present model under a well-motivated speculation. A more rigorous derivation will be given in the following chapters. The reason for us to make such estimate is that it involves less mathematics than the rigorous derivation but provides the correct physical picture.

6.1 THE HAGEDORN TEMPERATURE

It is well known that, in any string theory, there commonly exists an exponential growth in the density of string oscillations as a function of the mass. This is essentially because the string is a one-dimensional extended object. The number of oscillations at the n^{th} level grows roughly like $\exp(C\beta)$ with C a constant [52]. This growth is so rapid that the partition function

$$Z = \text{Tr} e^{-\beta H} \quad , \quad 6-1$$

of the string gas converges only for sufficiently large β . This "limiting temperature" was anticipated in earlier speculations and known as the Hagedorn temperature [53]. It is associated with a

phase transition in recent studies of QCD strings [54,55].

Physically, the Hagedorn temperature is related to a transition point where the entropy becomes infinite and dominant. One might wonder if the Hagedorn transition is absent in the present model because it involves a rigidity term which may suppress spikes and make the string flat. However, from (4-38), we see that, as $T > T_c$, $\lambda_0 > 0$. From (4-37), we see that $\lambda_0 > 0$ means $\alpha_0 > 0$. We expect the Hagedorn temperature T_H larger than T_c , which would imply the bending modulus ($1/\alpha_0$) to be finite at T_H due to the vacuum condensate of the lagrange multiplier. Since the mean curvature in (2-27) contains higher derivatives, it becomes irrelevant at large scales. We then expect that the bending rigidity term in (2-27) would become irrelevant at large scalea at T_H . That is, the large distance behavior of the system will be governed by the Nambu-Goto term in (2-27) at T_H and the Hagedorn transition exists in the present model. (This will be further justified in the following two chapters by explicit calculations. Here we presume that this is so and estimate the Hagedorn temperature.)

To find the Hagadorn temperature for the present model, we write the path interal of the string as follows [56]:

$$Z = \int_0^{\infty} dA \Gamma(A) \quad , \quad 6-2$$

where the function $\Gamma(A)$ is proportional to the number of different string world sheets of a given area A and is defined by

$$\Gamma(A) = \int [dX] \exp \left\{ -\frac{\lambda_0}{2\alpha_0} \int d^2\xi (\partial_a X)^2 \right\} \delta \left(\int d^2\xi \rho_0 - A \right) \quad , \quad 6-3$$

where we have used the saddle point approximation to the lagrange multiplier and the X -fields only contain the physical transverse components. The λ fluctuation can be described by (4-46), which does not affect the Hagedorn temperature and can then be neglected here. Its role in determining the string susceptibility will be discussed in Chapter 8.

It is interesting to note that the δ -function in (6-3) can be simply neglected since $\int \rho_0 d^2\xi = 2\rho_0 \beta^2 = A$ is trivially satisfied.

In Chapter 4, to find the saddle point solution near T_c , we only considered the special case of $R \gg \beta$ or $\rho_0 \rightarrow \infty$ and calculated the log. determinants of the operator $(-\Delta)$ and $(-\Delta + \lambda_0)$ given by (4-24) and (4-27) respectively. The results (4-24) and (4-27) are correct

only in the limit $R' \gg \beta'$. To find the Hagedorn temperature, however, we have to consider a more general case where the ratio of R' to β' is arbitrary. In fact, the Hagedorn temperature is determined by the singular behavior of the path integral near $\rho_0 \rightarrow 0$.

For a general (ξ -independent) ρ_0 , Eq. (4-24) should be replaced by [40]

$$\det'(-\Delta) = e^{-\rho_0 \pi / 3} \prod_{n=1}^{\infty} (1 - e^{-4n\pi\rho_0})^2 \quad . \quad 6-4$$

Clearly, the infinite product factor on the RHS of (6-4) tends to one as $\rho_0 \rightarrow \infty$ and can therefore be neglected. This is the case considered in Chapters 4 and 5. However, for a general ρ_0 and in particular, for small values of ρ_0 , the large n contribution to the path integral becomes dominant.

Integrating over x^μ fields in (6-3), Using (6-4) and concentrating on the large n behavior, we have

$$\Gamma \sim \det'{}^{-(d-2)/2}(-\Delta) \sim \prod_{n=1}^{\infty} (1 - e^{-4n\pi\rho_0})^{-(d-2)} \quad . \quad 6-5$$

Let

$$\omega = e^{-4\pi\rho_0} \quad , \quad 6-6$$

and

$$G(\omega) = \prod_{n=1}^{\infty} (1-\omega^n)^{-(d-2)} = \sum_{n=1}^{\infty} d_n \omega^n \quad . \quad 6-7$$

One can project out the level density d_n from $G(\omega)$ by a contour integral on a small circle about the origin

$$d_n = \frac{1}{2\pi i} \oint \frac{G(\omega)}{\omega^{n+1}} d\omega \quad . \quad 6-8$$

Since $G(\omega)$ vanishes rapidly for $\omega \rightarrow 1$, that is, $\rho_0 \rightarrow 0$, while if n is very large, ω^{n+1} is very small for $\omega < 1$. There is consequently, for large n , a sharply defined saddle point for ω near 1. It is a classic result from number theory due to Hardy and Ramanujan^[52] and was derived in the context of the (open) string due to Huang and Weinberg^[52] that as $n \rightarrow \infty$

$$d_n \sim (\text{const.}) n^{-(d+1)/4} \exp(2\pi\sqrt{(d-2)n/6}) \quad . \quad 6-9$$

In the usual Nambu-Goto string^[57], the number n is related to the the squared mass of the (open) string and the string tension

$$n = m^2 / 2\pi\sigma_0 \quad . \quad 6-10$$

In the present case, the string tension is replaced by the condensation of the Lagrange multiplier λ_0/α_0 . We have, instead of (6-10),

$$n = m^2 \alpha_0 / 2\pi \lambda_0 \quad . \quad 6-11$$

Using (6-11), the density of levels as a function of mass is asymptotically

$$\rho(m) \sim m^{-(d-1)/2} \exp(m/m_0) \quad , \quad 6-12$$

where

$$m_0 = \sqrt{\frac{3\lambda_0}{(d-2)\pi\alpha_0}} = T_H \quad . \quad 6-13$$

The level density grows so rapidly with mass that the partition function (6-1) develops a singularity at the temperature $T_H = m_0$ which is known as the Hagedorn temperature^[53]. What is interesting here is that it is the condensation of the Lagrange multiplier λ_0/α_0 , instead of the string tension σ_0 , which enters (6-13). This leads us to expect that T_H may take some different (larger) values than T_c given by (5-1) and to speculate a different kind of phase transition than the smooth-rough transition discussed in Chapter 5 near T_H .

We want to express T_H in terms of σ_0 which is the unique scale in the present model. (Since the bending rigidity $1/\alpha_0$ is dimensionless and asymptotically free, it does not provide a basic scale in the model. That is, the scale Λ should be determined by the theory. This is reminiscent of the situation in QCD where no basic parameter is present except the number of colors N_c which corresponds to the bulk dimensions d in the present model.) This involves three quantities T_H , λ_0 and α_0 (or Λ). So we need three independent equations involving these three quantities to determine them. These equations are (6-13) determined from the exponential increasing level density, the saddle point solution (4-37) representing the asymptotic freedom of the bending rigidity and the saddle point solution (4-38) determined from the condition that the effective string tension vanishes at T_c . (We will see that the last condition is equivalent to the tachyon free condition in the next chapter.)

To solve for λ_0/α_0 at T_H , we first rewrite the saddle point equation (4-38) or (4-39) as follows

$$\sigma_{\text{eff}} = \left(\sigma_0 + \frac{(d-2)\lambda_0}{8\pi} \right) \left(1 - \frac{(d-2)\pi}{3\beta_H^2 (\sigma_0 + (d-2)\lambda_0/8\pi)} \right)^{1/2} \rightarrow 0 \quad , \quad 6-14$$

where we have neglected the $I(a)$ term since it is exponentially small for large λ_0 (see (4-30)) and presumed that the critical exponent $\nu=2/d_H$ equals $1/2$ at T_H which will be proven soon (see (6-27) below). Substituting (6-13) into (6-14), we find

$$\frac{\lambda_0}{\alpha_0} = \sigma_0 + \frac{(d-2)\lambda_0}{8\pi} \quad . \quad 6-15$$

Comparing (6-15) with the classical equation (2-31), we see that the quantum fluctuations effectively change the negative (classical) rigidity term contribution to λ_0/α_0 by a positive value of $(d-2)\lambda_0/8\pi$. As a result, the vacuum condensation, the ratio λ_0/α_0 , is not a constant σ_0 , but increases with λ_0 . This confirms our previous expectation that $T_H > T_c$.

To solve for λ_0/α_0 in (6-15), we use the saddle point equation (4-37) and set

$$\frac{1}{\alpha_0} = \frac{(d-2)}{8\pi} \ln \frac{\Lambda^2}{\lambda_0} = \frac{(d-2) x}{8\pi} \quad . \quad 6-16$$

Substituting (6-16) into (6-15) gives

$$x \equiv \ln \frac{\Lambda^2}{\lambda_0} = \frac{8\pi\sigma_0}{\lambda_0(d-2)} + 1 \quad . \quad 6-17$$

From (6-17), we find

$$\Lambda^2 = \lambda_0 \exp \left(\frac{8\pi\sigma_0}{(d-2)\lambda_0} + 1 \right) \quad . \quad 6-18$$

Using (6-18) we find from $\delta\Lambda^2/\delta\lambda_0|_{\lambda=\lambda^*}=0$ and $\delta^2\Lambda^2/\delta\lambda_0^2|_{\lambda=\lambda^*}>0$

$$\lambda_0^* = \frac{8\pi\sigma_0}{d-2}, \quad \alpha_0 = \frac{4\pi}{d-2}, \quad ,$$

and $\frac{\lambda_0^*}{\alpha_0} = 2\sigma_0 \quad . \quad 6-19$

Substituting (6-19) into (6-13) gives

$$T_H = \sqrt{\frac{6\sigma_0}{(d-2)\pi}} = \sqrt{2} T_c \quad . \quad 6-20$$

Though (6-20) is derived for open strings it holds also for closed strings. This is easy to see (and will be proved in Chapter

8). For closed string the level density $d_n^{\text{close}} \propto (d_n)^2$ where d_n is

given by (6-9). But this does not change m_0 in (6-13) since (6-11)

must be replaced by $4n = m^2 \alpha_0 / 2\pi \lambda_0$ in the case of closed string.

Eq. (6-20) implies the existence of a second phase transition in the present model other than the smooth-rough transition which

is quite different from other string models. In the Nambu-Goto string^[13,54] and the Polyakov-Kleinert string^[12,46,55], there is only one phase transition. It is interesting to note that in these models, T_c is determined in a similar way as shown in Chapters 4 and 5, that is, determined by the condition that the effective string tension starts to vanish in the large A limit, while T_H is determined by the exponential increasing level density in the large n limit as shown above. It turns out that $T_c=T_H$ in these string models.

This can be understood as follows. A string theory can only have one phase transition at most if the singularities at the transitions are tachyonic. (Here the term tachyonic singularity means that beyond the transition, the squared mass becomes negative.) The reasoning is the following. Suppose the model has two tachyonic phase transitions with transition temperatures $T(1)$ and $T(2)$. To be definite, suppose $T(2)>T(1)$. But this is impossible since in the region $T(1)<T<T(2)$, the model is ill-defined because of the tachyonic singularity. That is, we only have $T(1)=T(2)$. This is the case of the Nambu-Goto string as well as the Polyakov-Kleinert string.

In the present model, T_c is not related to a tachyonic singularity as can be seen from (4-39): it is the vacuum

condensation of the Lagrange multiplier or the dynamically generated string tension which makes the effective string tension remain zero even at the temperature beyond T_c . This has also been explicitly shown in the above derivation of T_H . It is therefore possible for the present model to have a second phase transition other than the smooth-rough transition.

6.2 THE HAUSDORFF DIMENSION AT T_H

To determine the nature of the Hagedorn transition, we calculate the Hausdorff dimension at T_H or at the large n limit. This work has been done by Mitchell and Turok^[58] for the Nambu-Goto string. To be complete, we here mimic their calculations in terms of our notations.

The operator representing the mean squared radius of an open (orientable bosonic) string is defined by

$$\Delta r^2 = (d-1)/R' \int_0^{R'} d\xi^1 : (X^1(\xi^1) - q^1)^2 : \quad 6-21$$

where the symbol $: \quad :$ denotes normal ordering and q^1 the centre of mass coordinate of the string. The expectation value of Δr^2 averaged over all states at level n is given by

$$\overline{\Delta r^2} = \sum \frac{\langle \psi | \Delta r^2 | \psi \rangle}{P_n} \quad , \quad 6-22$$

where the sum is over all states at level n . Neglecting terms in (6-21) which do not contribute to (6-22), we can rewrite Δr^2 as follows

$$\Delta r^2 = \frac{(d-1)\alpha_0}{\pi\lambda_0} \hat{R} \quad \text{and} \quad \hat{R} = \sum_{n>0} n^{-2} \alpha_{-n}^1 \alpha_n^1 \quad , \quad 6-23$$

where we have used the general solution of the X fields which satisfies the equation of motion of the Nambu-Goto string with the string tension λ_0/α_0 , i.e.,

$$X^i(\xi^1) = q^i + i \sqrt{\frac{\alpha_0}{\pi\lambda_0}} \sum_{n \neq 0} n^{-1} \alpha_n^i \cos(n\pi\xi^1/R') \quad . \quad 6-24$$

The trick used in Ref. [58] is to consider the trace of the matrix $\omega^{\hat{N}} \chi^{\hat{R}}$ with $\hat{N} = \sum_{n>0} n \alpha_{-n}^i \alpha_n^i$ ($i=1,2,\dots,d-2$):

$$\text{tr}(\omega^{\hat{N}} \chi^{\hat{R}}) = \prod_{n=1}^{\infty} (1 - \omega^n \chi^{1/n})^{-1} \left(\prod_{n=1}^{\infty} (1 - \omega^n) \right)^{3-d} \quad . \quad 6-25$$

Differentiate (6-25) with respect to χ and then set $\chi=1$. This will give a series of terms and the coefficient of ω^n will tell us the

sum of the \hat{R} values at level n .

$$(d/d\chi) \text{tr}(\omega^{\hat{N}} \chi^{\hat{R}})_{\chi=1} = (1/(d-2)) G(\omega) \ln G(\omega) \quad , \quad 6-26$$

with $G(\omega)$ given by (6-7). To determine the coefficient of ω^n we use a similar procedure to that leading from (6-8) to (6-9). The result is

$$d'_n = d_n \sqrt{\frac{\pi^2 n}{6(d-2)}} \quad , \quad 6-27$$

and hence from (6-22) and (6-23) we have

$$\overline{\Delta r^2} = \frac{(d-1)\alpha_0}{\lambda_0} \sqrt{\frac{n}{6(d-2)}} = \frac{d-1}{2\sigma_0} \sqrt{\frac{n}{6(d-2)}} \quad , \quad 6-28$$

where we have used (6-19). But we know from (6-11) that \sqrt{n} is proportional to m which is in turn proportional to the proper

length of the string (defined by $m=2\sigma_0 L$). Thus we have the

important result that the mean squared radius of the string is

proportional to L at T_H . This means that typical string

configurations at the Hagedorn temperature are random walks which

in turn implies that the Hausdorff dimension of the string sheet is

4:

$$d_H = 4 \quad \text{at} \quad T_H \quad . \quad 6-29$$

Eq. (6-29) is consistent with our conjecture in Chapter 5 which predicts $2 \leq d_H \leq 4$. Though (6-29) is derived for the open string it holds also for the closed string by the same reason following (6-20).

At first sight, one may expect the Hagedorn transition to be first order since $\lambda_0 > 0$ at T_H , which would imply the correlation length to be finite. However, from (4-20), we see that λ_0 serves as the dynamically generated mass squared of one sector of X^μ fields, associated to the breakdown of the translation symmetry in 2 or $(d-2)$ dimensions. As discussed in Section 6.1, this massive sector of X^μ fields becomes irrelevant at T_H . On the other hand, it is the other massless sector of X^μ fields associated to the breakdown of the translation symmetry in d dimensions, as shown in (6-3), which governs the critical behavior of the system at temperatures near T_H . Therefore, the correlation length of the system at T_H may be infinite and the Hagedorn transition may not be first order. In fact, our detailed analysis in Section 8.2 will indicate that the Hagedorn transition is possibly of second order.

Chapter 7

Free Energy of a Gas of Rigid Strings

Finite temperature field theory can be studied by considering the propagation of fields on $\mathbb{R}^{d-1} \times S^1$, where S^1 has circumference $\beta = 1/T$. For strings at finite temperature, Polchinski [37] demonstrated by explicit computation that at the one loop level, the free energy of a thermal gas of closed strings can likewise be computed by carrying out world-sheet path integrals for string propagation on $\mathbb{R}^{d-1} \times S^1$ (for bosonic strings, $d=26$). Following Polchinski, in this chapter, we evaluate the free energy of a gas of (both closed and open) rigid strings on a torus and a cylinder respectively. This is compared with the free energy of a collection of free particles, and hence the mass spectrums of excitations of rigid strings are deduced. It turns out that the tachyon free condition leads to the saddle point solutions obtained in Chapter 4.

7.1 GENERALIZED GAUGE FIXING FOR A MINIMALLY IMMERSED TORUS

We now turn to consider the path integral of rigid strings on a

torus minimally immersed in d dimension^[30]. The action is given by:

$$S(X^\mu, g_{\circ ab}) = \sigma_\circ \int g_\circ^{1/2} d^2\xi + \frac{1}{2\alpha_\circ} \int g_\circ^{1/2} d^2\xi \{ (\Delta X^\mu)^2 + \lambda_\circ g_\circ^{ab} (\partial_a X^\mu \partial_b X^\mu - g_{\circ ab}) \} \quad 7-1$$

where the subscript \circ on g_{ab} denotes that the metric is flat and depends only on the Teichmuller parameters. Action (7-1) for a minimally immersed torus can be obtained from the Polyakov-Kleinert string action (2-14) by choosing the flat gauge

$$g_{ab} = g_{\circ ab} \quad ,$$

and assuming

$$\lambda^{ab} = \lambda \sqrt{g} g^{ab} \quad \text{and} \quad \lambda = \lambda_\circ \quad ,$$

where we have used a saddle point approximation for the lagrange multiplier λ . The λ fluctuations away from the saddle point can be described by the "anomaly" (4-46) and (4-47). Action (7-1) is an extension of (2-27) in the case of the minimally immersed torus.

To describe the torus, we take X^μ and $g_{\circ ab}$ to be periodic

functions of ξ^a :

$$X^\mu(\xi^1 + \beta, \xi^2) = X^\mu(\xi^1, \xi^2 + \beta) = X^\mu(\xi^1, \xi^2) \quad , \quad 7-2-a$$

$$g_{oab}(\xi^1 + \beta, \xi^2) = g_{oab}(\xi^1, \xi^2 + \beta) = g_{oab}(\xi^1, \xi^2) \quad . \quad 7-2-b$$

Thus the unit cell is simply $0 \leq \xi^1 \leq \beta, 0 \leq \xi^2 \leq \beta$.

The path integral over a minimally immersed torus can be written as

$$Z_{\text{torus}} = \int \frac{[dg_{oab}][dX^\mu]}{V} \exp(-S) \quad , \quad 7-3$$

where V is the volume of the residual symmetry group discussed in Chapters 2 and 4.

In order to carry out the metric integration we make a change of variables. Since the metric is flat, variation of the metric can then be resolved into changes arising from ξ and τ transformations. (Weyl transformations are absent for a flat metric.) We then write

$$\begin{aligned} \delta g_{oab} &= \nabla_a \delta \xi_b + \nabla_b \delta \xi_a + \frac{\partial g_{oab}}{\partial \tau_\alpha} \delta \tau_\alpha \\ &= \delta g_{oab}^{\text{G.C.}} + \delta g_{oab}^{\text{M.}} \quad , \end{aligned} \quad 7-4$$

where

$$\begin{aligned}\delta g_{\text{oab}}^{\text{G.C.}} &= \nabla_a \delta \xi_b + \nabla_b \delta \xi_a \\ &= g_{\text{oab}} \nabla^c \delta \xi_c^{\text{a.p.}} + (L \delta \xi^{\text{c.}})_{\text{ab}} \quad ,\end{aligned}\quad 7-5$$

and

$$(L \delta \xi^{\text{c.}})_{\text{ab}} = \nabla_a \delta \xi_b + \nabla_b \delta \xi_a - g_{\text{oab}} \nabla^c \delta \xi_c \quad . \quad 7-6$$

In (7-4), τ is the Teichmuller parameter $\tau = (\tau_1, \tau_2)$. The superscripts "a.p." and "c." on $\delta \xi$'s denote the area-preserving and the conformal transformations respectively. The integral over the metric thus separates into an integral over the general coordinate group and an integral over τ . We wish to determine the Jacobian defined by

$$Dg_{\text{oab}} = Dg_{\text{oab}}^{\text{(G.C.)}} Dg_{\text{oab}}^{\text{(Mod.)}} = [d\delta \xi \, d^2\tau]^2 J(\tau) \quad . \quad 7-7$$

In (7-7), $Dg_{\text{oab}}^{\text{(G.C.)}}$ is determined by

$$Dg_{\text{oab}}^{\text{(G.C.)}} = [d\delta \xi] J_{\text{G.C.}} = [d\delta \xi^{\text{a.p.}} \cdot d\delta \xi^{\text{c.}}] J_{\text{G.C.}} \quad . \quad 7-8$$

The Jacobian $J_{\text{G.C.}}$ is determined by (4-7), and therefore

$$Dg_{\text{oab}}^{\text{(G.C.)}} = \det^{1/2}(-\delta_{\text{ab}} \Delta) \det^{1/2}(L_1 + L_1) [d\delta \xi^{\text{a.p.}} \cdot d\delta \xi^{\text{c.}}] \quad , \quad 7-9$$

where

$$(L^+ L \delta \xi^{\text{c.}})_a = -\nabla^b (\nabla_a \delta \xi_b + \nabla_b \delta \xi_a - g_{\text{oab}} \nabla^c \delta \xi_c) \quad . \quad 7-10$$

The primes on the determinants omit the zero modes.

In (7-7), $Dg_{ab}^{(Mod.)}$ is given by [37]

$$Dg_{ab}^{(Mod.)} = \frac{\det \langle \partial g_{ab} / \partial \tau_\alpha, \phi_\beta \rangle}{\det (\phi_\alpha, \phi_\beta)^{1/2}} [d^2 \tau] = \det^{1/2} (f_{\alpha\beta}) [d^2 \tau] \quad , \quad 7-11$$

where $\{\phi_\alpha\}$ are the zero modes of L^+ and $f_{\alpha\beta}$ are defined by (from

now on, we drop the subscript \circ on the metric and define $g=g(\tau)$)

$$f_{\alpha\beta} = g^{ac} g^{bd} f_{ab,\alpha} f_{cd,\beta} \quad ,$$

$$f_{ab,\alpha} = \frac{\partial g_{ab}}{\partial \tau_\alpha} - \frac{1}{2} g_{ab} g_{cd} \frac{\partial g_{cd}}{\partial \tau_\alpha} \quad . \quad 7-12$$

There are also zero modes of L contained in $[d\delta\xi]$, which should be separated, we find [37]

$$[d\delta\xi d^2 \tau] = \left(\frac{\det Q_{AB}}{V_T^c} \right)^{-1/2} [d\delta\xi d^2 \tau]' \quad , \quad 7-13$$

where

$$Q_{AB} = \frac{1}{\beta^2} \int d^2 \xi \sqrt{g} g^{ab} \zeta_A^a \zeta_B^b \quad , \quad 7-14$$

$$V_T = \frac{1}{\beta^2} \int d^2 \xi \sqrt{g} \quad , \quad 7-15$$

and $\zeta_A^a = \delta_A^a$ ($A=1,2,\dots,c$) represent c independent conformal Killing vectors (the zero modes of L) on the torus. It is well known that

$$c = \begin{cases} 2 & \text{for a torus,} \\ 1 & \text{for a cylinder,} \\ 0 & \text{for a surface with genus } > 1 \end{cases} . \quad 7-16$$

Gathering all these pieces, the Jacobian in (7-7) is given by

$$J(\tau) = \det^{1/2} f_{\alpha\beta} \left(\frac{\det Q_{AB}}{V_T^2} \right)^{-1/2} \det'(-\Delta) \det'(-\Delta + \lambda_0) \quad , \quad 7-17$$

where we have used (4-10) and (4-11), which means that a generalized (covariant) gauge fixing has been used.

For a torus, we have

$$g_{ab} = \begin{pmatrix} 1 & \tau_1 \\ \tau_1 & |\tau|^2 \end{pmatrix} \quad \text{and} \quad g^{ab} = \begin{pmatrix} |\tau|^2 & -\tau_1 \\ -\tau_1 & 1 \end{pmatrix} . \quad 7-18$$

A straightforward calculation gives

$$\det^{1/2} f_{\alpha\beta} = 2/\tau_2^2 \quad , \quad V_T = \tau_2 \quad , \quad 7-19$$

$$\text{and} \quad \det Q_{AB} = \tau_2^4 \quad . \quad 7-20$$

Therefore, (7-17) becomes,

$$J(\tau) = (1/\tau_2^3) \{ \det'(-\Delta) \det'(-\Delta + \lambda_0) \} \Big|_T \quad . \quad 7-21$$

7.2 PATH INTEGRAL ON A MINIMALLY IMMERSED TORUS

Integration over X^μ can be carried out as follows. The metric for small variations in X^μ is defined as

$$\|\delta X^\mu\|^2 = \frac{1}{\beta^2} \int d^2\xi \sqrt{g_0} \delta X^\mu \delta X^\mu \quad . \quad 7-22$$

The measure for X^μ integration is defined in terms of the Gaussian integral:

$$\prod_\mu \int [d\delta X^\mu] e^{-\|\delta X^\mu\|^2/2} = 1 \quad . \quad 7-23$$

To carry out the X^μ integration, we separate the constant piece

$$X^\mu(\xi) = X_0^\mu + X'^\mu(\xi) \quad , \quad 7-24$$

where $X'^\mu(\xi)$ is orthogonal to the constant: $dX = dX_0 dX'$. The corresponding measure is defined by

$$[dX] = [dX_0 dX'] J_X \quad , \quad 7-25$$

where J_X is determined by the normalization (7-23), that is,

$$\begin{aligned}
1 &= \prod_{\mu} \int [dX_{\circ}^{\mu}] e^{-\frac{1}{2\beta^2} \int d^2\xi \sqrt{g_{\circ}} X_{\circ}^{\mu 2}} \int [d\delta X^{\prime\mu}] e^{-\| \delta X^{\prime} \|^2 / 2} \\
&= \prod_{\mu} \left\{ \frac{2\pi\beta^2}{\int d^2\xi \sqrt{g_{\circ}}} \right\}^{1/2} \int [d\delta X^{\prime\mu}] e^{-\| \delta X^{\prime} \|^2 / 2}
\end{aligned} \tag{7-26}$$

We then find

$$\begin{aligned}
J_X &= \prod_{\mu} \int [d\delta X^{\prime\mu}] e^{-\| \delta X^{\prime} \|^2 / 2} \\
&= \begin{cases} \left\{ \frac{\int d^2\xi \sqrt{g_{\circ}}}{2\pi\beta^2} \right\}^{d/2} & \text{as } \lambda_{\circ} \neq 0 \end{cases} , \tag{7-27}
\end{aligned}$$

$$= \begin{cases} \left\{ \frac{\int d^2\xi \sqrt{g_{\circ}}}{2\pi\beta^2} \right\}^d & \text{as } \lambda_{\circ} = 0 \end{cases} , \tag{7-28}$$

where, in (7-28), we have used the fact that due to the higher derivatives in the action (7-1), there are $2d$ zero modes for X^{μ}

fields in the (on-shell) case of $\lambda_{\circ}=0$. In this thesis, we are

mainly interested in the generic (off-shell) case of $\lambda_{\circ}\neq 0$. The

integral over X_{\circ}^{μ} diverges and can be regulated by putting the

system in a periodic box of dimensions $L^1 L^2 \dots L^d$. Using (7-27), we

perform the integral over $X^{\prime\mu}$ to obtain

$$Z_T = \left(\frac{\lambda_0}{\alpha_0}\right)^{d/2} \prod_{\mu} L^{\mu} \int \frac{d^2\tau}{2\pi\tau_2} \exp \left\{ -\left(\sigma_0 - \frac{\lambda_0}{\alpha_0}\right) \int d^2\xi \sqrt{g} \right\} \\ \times (\tau_2/2\pi)^{d/2-1} \left\{ \det'(-\Delta) \det'(-\Delta/\lambda_0+1) \right\}^{-d/2+1}, \quad 7-29$$

where we have used a formula, for a constant C and an operator F,

$$\det'(CF) = \frac{1}{C} \det'(F) \quad , \quad 7-30$$

and the relation

$$V = \text{order}(\tilde{D}) \int [d\delta\xi]' \quad \text{with} \quad \text{order}(\tilde{D}) = 1 \quad . \quad 7-31$$

This is because the path integral (7-29) is not invariant under the modular transformation $\tau \rightarrow -1/\tau$ which corresponds to the diffeomorphisms: $\xi^1 \rightarrow -\xi^1$, $\xi^2 \rightarrow -\xi^2$ (which respect the orientation, the periodicity (7-2) but do not connect with the identity).

$\text{Det}'(-\Delta)$ has been calculated in ref. [37]:

$$\det'(-\Delta) = \tau_2^2 e^{-\pi\tau_2/3} |f(e^{2\pi i\tau})|^4 \quad , \quad 7-32$$

where

$$f(e^{2\pi i\tau}) = \prod_{n=1}^{\infty} (1 - e^{2\pi in\tau}) \quad . \quad 7-33$$

The determinant of $(-\Delta/\lambda_0 + 1)$ is evaluated in Appendix B (see also [38]):

$$\det'(-\Delta/\lambda_0 + 1) = \exp \left[\frac{\tau_2 a^2}{4\pi} \left(1 + \ln \frac{\Lambda^2}{\lambda_0} \right) + 2\pi\tau_2 I(a) \right]$$

$$x \left| f(e^{2\pi i w_+}) \right|^4 (1 - e^{-\tau_2 a})^2 \quad , \quad 7-34$$

where $I(a)$ and a are defined by (4-28) and (4-29) respectively and $w_+ = m\tau_1 + i\tau_2 (m^2 + a^2/4\pi^2)^{1/2}$.

Substituting (7-32)-(7-34) into (7-29) gives

$$Z_T = \left(\frac{\lambda_0}{\alpha_0} \right)^{d/2} \prod_{\mu} L_{\mu} \int_{\tilde{F}} \frac{d^2 \tau}{2\pi\tau_2^2} (2\pi\tau_2)^{1-d/2} \left| f(e^{2\pi i \tau}) \right|^{2(2-d)}$$

$$x \left| f(e^{2\pi i w_+}) \right|^{2(2-d)} (1 - e^{-\tau_2 a})^{2-d} \exp(-\sigma_{\text{eff.}} A) \quad , \quad 7-35$$

where

$$\sigma_{\text{eff.}} = \sigma_0 - \frac{\lambda_0}{\alpha_0} + \frac{(d-2)\lambda_0}{8\pi} \left(1 + \ln \frac{\Lambda^2}{\lambda_0} \right) - \frac{\pi(d-2)}{6\beta^2} (1 - 6I(a)) \quad , \quad 7-36$$

$$\tilde{F} = \left\{ -\frac{1}{2} \leq \text{Re } \tau \leq \frac{1}{2}, \text{Im } \tau > 0 \right\} \quad ,$$

and $A = \tau_2 \beta^2$. 7-37

We immediately see that (7-36) agrees with (4-34). Comparing (7-37)

with (4-32) shows that $\tau_2 \sim 2\rho_0$. Indeed, the geometrical meaning of τ_2 is just the ratio of the two length scales (or radii) of the torus.

We note that the region of integration over the Teichmuller

parameter τ in (7-35) is not restricted to the fundamental domain^[37]:

$$F = \{-1/2 \leq \text{Re}\tau \leq 1/2, \text{Im}\tau > 0, |\tau| > 1\} \quad . \quad 7-38$$

This is because the path integral (7-35) is invariant under

$$\tau \rightarrow \tau + 1 \quad , \quad 7-39$$

but changes under

$$\tau \rightarrow -1/\tau \quad . \quad 7-40$$

The invariance of the path integral (7-35) under the transformation (7-39) means that, when we merge a closed string back to itself at the time $2\pi\beta$, a twist by an angle 2π in the final string as compared with the initial one makes no change on the path integral. (In fact, the geometrical meaning of τ_1 is just an arbitrary twist. See also below.) The fact that (7-35) change under the transformation (7-40) means that the two directions, the spatial and the "time" directions, of the string worldsheet are not on the same footing. In other words, the modular invariance of the theory is spontaneously broken. It is the vacuum condensation of the lagrange multiplier which makes the path integral (7-34) change under modular transformation (7-40). (Recall that in the case $\lambda_0=0$,

the path integral (7-27) is modular invariant.) As a result of the vacuum condensation of the lagrange multiplier, we will see below that the theory is free of tachyons.

7.3 FREE ENERGY FOR A TORUS

In the same fashion as for the Polyakov's bosonic string we evaluate the free energy $F(\beta)$ for a gas of rigid strings in the limit $L^3, L^4, \dots, L^d \rightarrow \infty, L^1 = L^2 = \beta$ fixed^[37]

$$F(\beta) = - \left(\prod_{\mu} L^{\mu} \right)^{-1} Z_{\text{connected}} \quad , \quad 7-41$$

where the subscript "connected" on the path integral simply means that all the (disconnected) vacuum-vacuum amplitudes in the path integral have been excluded. The leading β -dependence in $F(\beta)$ comes from tori which wind r times around the compact 1-direction. (Note that, to describe the statistical mechanics of strings, the embedding space is chosen to be $R^{d-1} \times S^1$. This differs from the statistical description of random surfaces though both Hamiltonians may have the same form.) The boundary condition (7-2-a) is then modified to

$$x^\mu(\xi^1 + \beta, \xi^2) = x^\mu(\xi^1, \xi^2) + r\beta\delta_1^\mu \quad \text{7-42}$$

$$x^\mu(\xi^1, \xi^2 + \beta) = x^\mu(\xi^1, \xi^2) \quad \text{7-43}$$

while (7-2-b) remains unchanged. It is convenient to separate x^μ into a periodic piece and a linear piece,

$$x^\mu(\xi^1, \xi^2) = y^\mu(\xi^1, \xi^2) + r\xi_1^\mu \delta_1^\mu \quad \text{7-44}$$

The action (7-1) then becomes

$$S(X, g) = S(y, g) + \frac{r^2\beta^2\lambda_0}{2\tau_2\alpha_0} \quad \text{7-45}$$

while the free energy (7-41) takes the form

$$F_T(\beta) = -\left(\frac{\lambda_0}{\alpha_0}\right)^{d/2} \int_0^\infty \frac{d\tau_2}{2\pi\tau_2^{-1/2}} \int_0^{1/2} d\tau_1 (2\pi\tau_2)^{1-d/2} \left| f(e^{2\pi i\tau_1}) \right|^{2(2-d)} \\ \times \left| f(e^{2\pi i\tau_1}) \right|^{2(2-d)} (1 - e^{-\tau_2 a})^{2-d} \exp(-\sigma_{\text{eff}} A) \\ \times \sum_{r=1}^{\infty} e^{-r^2\beta^2\lambda_0/2\alpha_0\tau_2} \quad \text{7-46}$$

In order to understand the content of (7-46) we compare it with the free energy for a collection of free particles whose spectrum is $\omega_k = (k^2 + m^2)^{1/2}$:

$$\begin{aligned}
F(\beta, m^2) &= \frac{1}{\beta} \int \frac{d^{d-1}k}{(2\pi)^{d-1}} \ln(1 - e^{-\beta\omega_k}) \\
&= - \int_0^\infty \frac{ds}{s} (2\pi s)^{-d/2} \sum_{r=1}^\infty e^{-m^2 s/2 - r^2 \beta^2/2s}
\end{aligned} \tag{7-47}$$

In terms of occupation-number operators of transverse oscillators $\hat{N}_{ni}^{(1)}$, $\hat{\tilde{N}}_{ni}^{(1)}$, $\hat{N}_{ni}^{(2)}$, $\hat{\tilde{N}}_{ni}^{(2)}$ and $\hat{N}_i^{(3)}$, the spectrum of smooth strings

is given by

$$\begin{aligned}
\hat{m}^2(a) &= 4\pi \frac{\lambda_o}{\alpha_o} \left\{ \sigma_{\text{eff}} \frac{\beta^2}{2\pi} + \sum_{i=1}^{d-2} \sum_{n=1}^\infty n (\hat{N}_{ni}^{(1)} + \hat{\tilde{N}}_{ni}^{(1)}) \right. \\
&\quad \left. + \sum_{i=1}^{d-2} \sum_{n=1}^\infty \tilde{n} (\hat{N}_{ni}^{(2)} + \hat{\tilde{N}}_{ni}^{(2)}) + \frac{a}{2\pi} \sum_{i=1}^{d-2} \hat{N}_i^{(3)} \right\} \tag{7-48}
\end{aligned}$$

subject to the closed string constraints:

$$\sum_{i=1}^{d-2} \sum_{n=1}^\infty n (\hat{N}_{ni}^{(1)} - \hat{\tilde{N}}_{ni}^{(1)}) = 0 \tag{7-49-a}$$

$$\sum_{i=1}^{d-2} \sum_{n=1}^\infty \tilde{n} (\hat{N}_{ni}^{(2)} - \hat{\tilde{N}}_{ni}^{(2)}) = 0 \tag{7-49-b}$$

where

$$\tilde{n} = \sqrt{n^2 + a^2/4\pi^2} \tag{7-50}$$

In (7-48) and (7-49), n is the mass level discussed in the last chapter while $\hat{N}_{ni} = \alpha_{-n}^i \alpha_n^i$ which should not be confused with $\hat{N} = \sum_{n>0} n \hat{N}_{ni} = \sum_{n>0} n \alpha_{-n}^i \alpha_n^i$ in (6-25). The differences between n and \tilde{n}

or \hat{N}_{ni} and $\hat{N}_{\tilde{n}i}$ mean that the energy degeneracies due to the higher derivatives in the action (7-1) are lifted by the condensation of the Lagrange multiplier λ_0 (note that $a^2 = \lambda_0 \beta^2$ in \tilde{n}).

Summing (7-47) over oscillator spectrum (7-48) subject to constraints (7-49) yields exactly the free energy given in (7-46) with the identification

$$\tau_2 = s\lambda_0/\alpha_0 \quad 7-51$$

Note that

$$\int_{-1/2}^{1/2} d\tau_1 \exp \left\{ 2\pi i \tau_1 \sum_{i=1}^{d-2} \sum_{n=1}^{\infty} n (\hat{N}_{ni}^{(1)} - \hat{N}_{ni}^{(1)}) \right\} = \begin{cases} 1 & \text{if } \sum_{i=1}^{d-2} \sum_{n=1}^{\infty} n (\hat{N}_{ni}^{(1)} - \hat{N}_{ni}^{(1)}) = 0 \\ 0 & \text{otherwise} \end{cases} \quad 7-52-a$$

and similarly

$$\int_{-1/2}^{1/2} d\tau_1 \exp \left\{ 2\pi i \tau_1 \sum_{i=1}^{d-2} \sum_{n=1}^{\infty} \tilde{n} (\hat{N}_{\tilde{n}i}^{(2)} - \hat{N}_{\tilde{n}i}^{(2)}) \right\} = \begin{cases} 1 & \text{if } \sum_{i=1}^{d-2} \sum_{n=1}^{\infty} \tilde{n} (\hat{N}_{\tilde{n}i}^{(2)} - \hat{N}_{\tilde{n}i}^{(2)}) = 0 \\ 0 & \text{otherwise} \end{cases} \quad 7-52-b$$

We then see that the τ_1 integral in (7-46) enforces the constraints (7-48). This is not too surprising since, as mentioned before, the

geometrical meaning of τ_1 is just an angle (over 2π), a twist in the final string as compared with the initial one when we merge a closed string back with itself in a period of time $2\pi\beta$. Since there is no such twist when we merge an open string as above, we expect that there is no such τ_1 integral in the free energy of open strings. In the next section, we will show that it is indeed so.

There are a number of interesting features to take note of. From (7-48) we see that there are only transverse modes in the mass spectrum. The longitudinal modes $\hat{N}_{n_1}^{(1)}$, $\hat{N}_{n_1}^{(2)}$ and $\hat{N}_{\tilde{n}_1}^{(1)}$, $\hat{N}_{\tilde{n}_1}^{(2)}$ have been removed by the gauge fixing procedure discussed in Sect. 7.1. In the spectrum (7-48), the number operators $\hat{N}_{n_1}^{(1)}$ and $\hat{N}_{\tilde{n}_1}^{(2)}$ represent independent right movers (the former associate with the operator $-\Delta$ while the latter with $-\Delta + \lambda_0$) while $\hat{N}_{n_1}^{(2)}$ and $\hat{N}_{\tilde{n}_1}^{(1)}$ are the left movers. These are commuting operators. $N_1^{(3)}$ arises from the zero-point fluctuations of the string. The constraints (7-49) are the usual ones for closed string, namely, the number of left-moving degrees of freedom coincides with those of the right-moving degrees of freedom.

Now consider the lowest mass state. The squared mass for this

state in the presence of extrinsic curvature is given by

$$m_o^2(a) = 2\sigma_{\text{eff.}} a^2 / \alpha_o \quad , \quad 7-53$$

where $\sigma_{\text{eff.}}$ is given by (7-36). We immediately see that the requirement of vanishing of tachyon mass is just the one of vanishing of the effective string tension, i.e.,

$$\alpha_o = \frac{8\pi / (d-2)}{\ln \Lambda^2 / \lambda_o} \quad , \quad 7-54-a$$

$$\lambda_o = -\frac{8\pi\sigma_o}{d-2} + \frac{4\pi^2}{3\beta^2} (1 - 6I(a)) \quad , \quad 7-54-b$$

which coincide with the saddle point solutions (4-37) and (4-38).

It can also be seen from (7-48) that there are generically no massless spin-2 states in the excitation spectrum of rigid strings even in the limit of $\lambda_o=0$. This agrees with the fact that rigid string theory does not have modular invariance^[59].

7.4 FREE ENERGY FOR A CYLINDER

Following Burgess and Morris^[60] we choose the cylinder as the region

$$(\xi^1, \xi^2) \in [0, \beta/2] \times [0, \beta] \quad , \quad 7-55$$

with $(\xi^1, 0)$ identified with (ξ^1, β) . This can be obtained from the torus defined by $0 \leq \xi^1 \leq \beta$ and $0 \leq \xi^2 \leq \beta$ through the mapping f_c :

$$f_c(\xi^1, \xi^2) = (\beta - \xi^1, \xi^2) \quad . \quad 7-56$$

The Teichmuller parameters of the cylinder are obtained by requiring the metric $g_{ab}(\tau)$ on the torus to be invariant under f_c .

This has the effect of requiring $\tau_1 = 0$ and so there is only one real

parameter τ_2 in $g_{ab}(\tau)$ such that $0 < \tau_2 < \infty$. Therefore, for a

cylinder, we have

$$g_{ab} = \begin{pmatrix} 1 & 0 \\ 0 & \tau_2^2 \end{pmatrix} , \quad \sqrt{g} = \tau_2 , \quad v_c = \tau_2/2 \quad , \quad 7-57$$

$$\text{and } \det f_{22} = 2/\tau_2^2 \quad . \quad 7-58$$

Only one of the two conformal Killing vectors, ζ_2^a , defined on the

torus is even under f_c and so

$$c = 1 \quad . \quad 7-59$$

Evaluating $\det Q_{AB}$, we get

$$\det Q_{AB} = \det Q_{22} = \tau_2^3/2 \quad . \quad 7-60$$

The relationship between $\det'(-\Delta)|_C$ and $\det'(-\Delta)|_T$ has been found by Burgess and Morris^[60]:

$$\det'(-\Delta)|_C = \tau_2 \left(\det'(-\Delta)|_T \right)^{1/2} \Big|_{\tau=i\tau_2} \quad , \quad 7-61$$

where

$$\det'(-\Delta)|_T = \tau_2^2 \exp\left\{-\frac{\pi\tau}{3}\right\} \left| \prod_{n=1}^{\infty} (1-e^{2\pi i n \tau}) \right|^4 \quad . \quad 7-62$$

The quantity $\det'(-\Delta/\lambda_0+1)|_C$ is evaluated in the Appendix C. It is related with $\det'(-\Delta/\lambda_0+1)|_T$ as follows:

$$\det'(-\Delta/\lambda_0+1)|_C = (1-e^{-\tau_2 a}) e^{\tau_2 a} \left(\det'(-\Delta/\lambda_0+1)|_T \right)^{1/2} \quad , \quad 7-63$$

where $\det'(-\Delta/\lambda_0+1)|_T$ is given by (7-34). $\det'(L_1+L_1)|_C$ is given by

$$\det'(L_1+L_1)|_C = \left(\det'(-\Delta)|_T \right)^{1/2} \Big|_{\tau=i\tau_2} \quad . \quad 7-64$$

In (7-61), (7-63) and (7-64), we note that the determinants of the operators that occur in the theory for the cylinders are related to those for tori not linearly but by the exponent of one half. This result could have been expected since for a torus the periodic boundary conditions (7-2) must be satisfied which identify $(\xi^1+\beta, \xi^2)$ and $(\xi^1, \xi^2+\beta)$ with (ξ^1, ξ^2) . This requires that \log .

determinants $\text{Indet}'(-\Delta)$ and $\text{Indet}'(-\Delta/\lambda_0 + 1)$ contain sum over eigenvalues $m, n \in \mathbb{Z}$. In other words, the degeneracy of each eigenvalue $a_{m,n}$ (with m, n not zero simultaneously) is four for a torus. (For example, $a_{2,2} = a_{2,-2} = a_{-2,2} = a_{-2,-2}$.) For a cylinder, only $(\xi^1, \xi^2 + \beta)$ is identified with (ξ^1, ξ^2) . In this case, m runs over positive integers while n can be any integer. Therefore the degeneracy of each eigenvalue $a_{m,n}$ (with m, n not zero simultaneously) is two for a cylinder. This is the topological source of the power one half in (7-61), (7-63) and (7-64).

Combining all pieces of information together gives the free energy for open rigid strings in one loop:

$$F_C(\beta) = -\left(\frac{\lambda_0}{\alpha_0}\right)^{d/2} \int_0^\infty \frac{d\tau_2}{2\pi\tau_2^2} (2\pi\tau_2)^{1-d/2} \left| \prod_{n=1}^\infty (1 - e^{-2\pi n\tau_2}) \right|^{2-d} \\ \times \left| \prod_{n=1}^\infty (1 - e^{-2\pi\tilde{n}\tau_2}) \right|^{2-d} (1 - e^{-\tau_2 a})^{2-d} e^{-\sigma_{\text{eff.}} A} \sum_{r=1}^\infty e^{-r^2 \beta^2 \lambda_0 / 4\alpha_0 \tau_2}, \quad 7-65$$

where

$$A = \tau_2 \beta^2 / 2, \quad \tilde{n} = \sqrt{n^2 + a^2 / 4\pi^2}, \quad a^2 = \lambda_0 \beta^2, \quad 7-66$$

and

$$\sigma_{\text{eff.}} = \sigma_o - \frac{\lambda_o}{\alpha_o} + \frac{(d-2)\lambda_o}{8\pi} \left(1 + \ln \frac{\Lambda^2}{\lambda_o}\right) - \frac{\pi(d-2)}{6\beta^2} (1 - 6I(a)) + \frac{\sqrt{\lambda_o}(d-2)}{\beta} \quad 7-67$$

Eq. (7-66) can be compared with the free energy for a collection of free particles (7-47). In the same way as for the closed strings, we find the mass spectrum for the open rigid strings to be

$$\hat{m}^2(\lambda_o) = 2\pi \frac{\lambda_o}{\alpha_o} \left\{ \sigma_{\text{eff.}} \frac{\beta^2}{2\pi} + \sum_{i=1}^{d-2} \sum_{n=1}^{\infty} (n\hat{N}_{ni}^{(1)} + \tilde{n}\hat{N}_{\tilde{n}i}^{(2)}) + \frac{a}{2\pi} \sum_{i=1}^{d-2} \hat{N}_i^{(3)} \right\} \quad , \quad 7-68$$

where $\hat{N}_{ni}^{(1)}$, $\hat{N}_{\tilde{n}i}^{(2)}$ and $\hat{N}_i^{(3)}$ are number operators and commute with each other. Summing (7-47) over the mass spectrum (7-68) reproduces

(7-66) with the identification $\tau_2 = \lambda_o s / \alpha_o$. The ground state is one in which the number operators have zero eigenvalues. We find

$$m_o^2(a) = a^2 \sigma_{\text{eff.}} / \alpha_o \quad . \quad 7-69$$

where $\sigma_{\text{eff.}}$ is given by (7-67). We immediately see that the theory is free of tachyons if

$$\sigma_{\text{eff.}} = 0 \quad . \quad 7-70$$

That is

$$\alpha_{\circ} = \frac{8\pi/(d-2)}{\ln\Lambda^2/\lambda_{\circ}} \quad , \quad 7-71$$

and

$$\lambda_{\circ} + \frac{8\pi}{\beta} \sqrt{\lambda_{\circ}} = -\frac{8\pi\sigma_{\circ}}{d-2} + \frac{4\pi^2}{3\beta^2} (1 - 6I(a)) \quad . \quad 7-72$$

Eqs. (7-67), (7-71) and (7-72) agree with (4-34), (4-37) and (4-38)

respectively except for the $\sqrt{\lambda_{\circ}}$ term which is nonuniversal and corresponds to a constant term in the effective (thermal) potential defined by $\sigma_{\text{eff}} A = \beta V(\beta)$, arising from the zero-point fluctuation of the stretched string. Nevertheless, including such a term does not change the critical temperature T_c since T_c is determined at $\lambda_{\circ}=0$. Perhaps this term can be neglected due to the insensibility of experiments to a constant term in the potential.

Chapter 8

Hagedorn Temperature and the Phase Diagram

In Chapter 6, we estimated the Hagedorn temperature of the model by assuming the irrelevance of the rigidity term at this temperature. In this chapter, we rederive the Hagedorn temperature more rigorously than in Chapter 6 by using the free energy obtained in the last chapter. The phase diagram of the model is also worked out and compared with numerical simulations for discretized random surfaces with the topology of a torus with rigidity.

8.1 SINGULARITIES OF THE FREE ENERGY

We start by considering the free energy for open rigid strings (7-65) and focus on the $r=1$ contribution. First consider the upper limit where τ_2 goes to infinity. Since $A=\tau_2\beta^2/2$, we see that the only relevant term in (7-65) in this limit is

$$F(A) \underset{\tau_2 \rightarrow \infty}{\sim} A^{-d/2-1} \exp(-\sigma_{\text{eff.}} A) \quad 8-1$$

In the usual bosonic string, $-\sigma_{\text{eff.}} A = 4\pi\tau_2$ which corresponds to

a tachyon in the string spectrum^[37]. Therefore the thermopartition function of the bosonic string is actually mathematically ill-defined. In our case, however, there is no such divergence in the free energy (7-65) because of the absence of a tachyon in the string spectrum. The tachyon free condition determines the critical temperature T_c associated with the smooth-rough transition: In the rough phase, it is due to the condensation of the Lagrange multiplier or in other words, the dynamically generated string tension, the effective string tension remains zero and as a result, no tachyons appear in this phase.

Comparing (8-1) with the expression which defines the string susceptibility γ [3]:

$$\Gamma(A) = A^{\gamma-3} e^{KA} \quad , \quad 8-2$$

gives $\gamma=(4-d)/2$ for open rigid string at T_c . The same is true for closed rigid string as can be seen from (7-46). According to an important result of Durhuus, Frohlich and Jonsson^[61], in a class of models of random surfaces on hypercubic lattices, if $\gamma > 0$, then the surface is a branched polymer. On the contrary, for $\gamma < 0$, the average area of a planar surface at the critical point is finite. (To obtain a large surface it is possible by fixing the total area

to be large as in (6-3).) The marginal case is $\gamma=0$ which corresponds to $d=4$ in our case.

We next investigate the asymptotic behavior of (7-65) as $\tau_2 \rightarrow 0$. The examination of the path integral of strings made in Chapter 6 indicated that, as far as the behavior near $\tau_2=0$ is concerned, potential trouble can come from a divergence in the level density d_n at large n . We need therefore to examine the convergence of (7-65) at large n .

The integral over τ_2 can be evaluated in the asymptotic limit corresponding to large mass level, $n \rightarrow \infty$. By the expansion of the geometric series, we have

$$\begin{aligned} \left| \prod_{n=1}^{\infty} (1 - e^{-2\pi\tau_2 n}) \right|^{-(d-2)} &= \left[1 + \sum_{n=1}^{\infty} d(n) e^{-2\pi\tau_2 n} \right]^{d-2} \\ &\equiv 1 + \sum_{n=1}^{\infty} d_{(d-2)}(n) e^{-2\pi\tau_2 n} \end{aligned} \quad 8-3$$

For large n , $d_{(d-2)}(n)$ is given asymptotically by Huang and Weinberg [52]

$$d_{(d-2)}(n) \sim (n)^{-(d+1)/4} \exp \pi \left(\frac{2(d-2)n}{3} \right)^{1/2} \quad 8-4$$

In order to estimate $|\prod_{n>0} (1-e^{-2\pi\tau_2\tilde{n}})|^{-(d-2)}$ in (7-65), we proceed as

follows. Since for large n we have $\tilde{n} \rightarrow n$ and therefore

$$|\prod_{n>0} (1-e^{-2\pi\tau_2\tilde{n}})|^{-(d-2)} \approx |\prod_{n=1}^{n_0-1} (1-e^{-2\pi\tau_2\tilde{n}})|^{-(d-2)} \times |\prod_{n \geq n_0} (1-e^{-2\pi\tau_2 n})|^{-(d-2)}$$

8-5

In (8-5), n_0 can be estimated by the requirement

$$\frac{a^2}{4\pi^2 n_0^2} \sim \frac{1}{4\pi^2} \quad \text{or} \quad n_0 \sim a$$

8-6

Since the minimum value of a is zero, while that of n_0 is unity, we set

$$n_0 = c(a + 1) \quad , \quad 8-7$$

where $0 < c < \infty$ is to be determined. Let

$$\omega = e^{-2\pi\tau_2}, \quad f(\omega) = \prod_{n=1}^{\infty} (1-\omega^n) \quad \text{and} \quad f(\omega, n_0) = \prod_{n=n_0}^{\infty} (1-\omega^n) \quad 8-8$$

The asymptotic limit of (8-5) can be estimated following refs. [52]

[57] and [62], we find as $\omega \rightarrow 1$

$$\begin{aligned}
f(\omega, n_0) &= \prod_{n \geq n_0} \exp \ln(1 - \omega^n) = \exp - \sum_{n \geq n_0} \sum_{m > 0} \frac{(\omega^n)^m}{m} \\
&= \exp - \sum_{m > 0} \frac{(\omega^m)^{n_0}}{m} \sum_{n \geq 0} (\omega^m)^n \sim \exp - \sum_{m > 0} \frac{1}{m^2 (1 - \omega) n_0} \quad 8-9
\end{aligned}$$

Therefore

$$f(\omega, n_0) \sim \left(\exp - \frac{\pi^2}{6(1-\omega)} \right)^{1/n_0} \sim (f(\omega))^{1/n_0}, \quad 8-10$$

where n_0 is given by (8-7). Thus, as far as the asymptotic behavior as $\omega \rightarrow 1$ is concerned, we have

$$f(\omega) f(\omega, n_0) \sim (f(\omega))^{1+1/n_0} \quad 8-11$$

Putting all these results together and considering those terms for which $n \geq N \gg n_0$, (7-65) becomes asymptotically

$$\begin{aligned}
F(\beta) &\sim - \left(\frac{\lambda_0}{\alpha_0} \right)^{d/2} \int_0^\infty \frac{d\tau_2}{\tau_2} (2\pi\tau_2)^{-d/2} \sum_{n=N}^\infty \sum_{r=1}^\infty d_{(d-2) \cdot (1+1/n_0)}(n) \\
&\quad \times \exp - \left(2\pi n \tau_2 + \frac{r^2 \beta^2 \lambda_0}{4\alpha_0 \tau_2} \right) \\
&\sim - \sum_{n=N}^\infty \sum_{r=1}^\infty (n)^{d/4} K_{d/2} \left(\beta r \sqrt{\frac{2\pi n \lambda_0}{\alpha_0}} \right) d_{(d-2) \cdot (1+1/n_0)}(n) \quad , \quad 8-12
\end{aligned}$$

where an overall constant is omitted and $K_{d/2} [\beta r (2\pi n \lambda_0 / \alpha_0)^{1/2}]$ is a

modified Bessel function. For large n , $K_{d/2}$ behaves as

$$K_{d/2}(\beta r \sqrt{\frac{2\pi n \lambda_0}{\alpha_0}}) \xrightarrow{n \rightarrow \infty} \sqrt{\frac{\pi}{2}} (\beta r \sqrt{\frac{2\pi n \lambda_0}{\alpha_0}})^{-1/2} \exp - r \beta \sqrt{\frac{2\pi n \lambda_0}{\alpha_0}} \quad 8-13$$

Substituting (8-4) and (8-13) into (8-12) gives

$$F(\beta) \sim - \sum_{n=N}^{\infty} \sum_{r=1}^{\infty} (n)^{-\{(d-2) \cdot (1+1/n_0) - d + 4\}/4} \times \exp \pi \left\{ \frac{2(d-2)}{3} (1+1/n_0) n \right\}^{1/2} \exp - r \beta \sqrt{\frac{2\pi n \lambda_0}{\alpha_0}} \quad 8-14$$

The dominant contribution comes from the $r = 1$ term and the critical temperature is determined by equating the exponents in (8-14). We find

$$\beta_H = \sqrt{1 + 1/c(a+1)} \sqrt{\frac{(d-2)\pi\alpha_0}{3\lambda_0}} \quad 8-15$$

As $a \rightarrow 0$, the extrinsic curvature term dominates. In this case, we expect

$$1 + 1/c = 2 \quad 8-16$$

This gives $c=1$ and (8-15) becomes

$$\beta_H = \sqrt{1 + 1/(a+1)} \sqrt{\frac{(d-2)\pi\alpha_0}{3\lambda_0}} \quad 8-17$$

Comparing (8-17) with (6-13), we see that both agree nicely

since a in (8-17) is large at T_H . We check this explicitly:

$$a(T_H) = (\sqrt{\lambda_o} \beta)_{T_H} \approx \sqrt{(d-2)\pi\alpha(T_H)/3} = 2\pi/\sqrt{3} \quad . \quad 8-18$$

Therefore

$$\sqrt{1+1/(a+1)} \approx \sqrt{1+\frac{1}{2\pi/\sqrt{3}+1}} \approx 1.10 \quad . \quad 8-19$$

We can repeat the above computations for a torus. In this case, we consider the free energy of an ensemble of closed rigid strings (7-46). Comparing (7-46) with (7-65) we find that they are in fact quite similar. The τ_1 integral involved in (7-46) does not affect the result since the level density is dominated by the value at $\tau_1=0$ for $-1/2 \leq \tau_1 \leq 1/2$. Another difference between closed and open strings is that the former contains twice as many modes as the latter. This is reflected in (7-46) where the exponents of $|f(e^{2\pi i\tau})|$ and $|f(e^{2\pi iw_+})|$ are twice that in (7-65). Nevertheless, we note that the area of a torus is also twice as large as that of a cylinder. This is reflected in (7-46) not only by the area term but also by the exponents involving winding numbers. The latter are also twice as large as that in (7-65). As a result, the Hagedorn temperature for the closed string is the same as that for the open string.

8.2 THE STRING SUSCEPTIBILITY AT T_H

Our calculation below is inspired by the recent work^[63] which investigated the phase transition in Liouville theory. Setting

$\eta = \partial^2 \phi$ in the conformal anomaly (4-46) gives

$$(\text{Anomaly}) = \frac{1}{2\alpha_r} \int d^2 \xi \partial_a \phi \partial_a \phi \quad . \quad 8-20$$

Motivated by the resemblance of the ϕ action (8-20) to the Kosterlitz-Thouless (KT) model in the continuum, we inquire into the effects of vortexlike configurations of the form

$$\phi(\xi) = -\mu \ln(\xi) \quad , \quad 8-21$$

where $\xi = (\xi_1^2 + \xi_2^2)^{1/2}$ and we have centered the vortex at the origin

for notational convenience. For any μ , (8-21) is a solution of

$\partial^2 \phi = 0$, which is the classical Euler Lagrange equation from the

action (8-21), in the presence of a δ -function source of amplitude

$2\pi\mu$ at the origin.

We now demand that the area around a vortex such as (8-21) be convergent as seen in the d -dimensional space in which the string world sheet is embedded. (This requirement is necessary for the

ϕ -field configuration (8-21) to be interpreted as a regular vortex.) We can achieve this by integrating over a small region of linear dimension a around the vortex and requiring that the proper area

$$1/\Lambda^2 \simeq \int_0^a \exp[\phi(\xi)] d^2\xi \quad , \quad 8-22$$

be convergent. The local version of (8-22) can be used to define $a(\xi)$ which is a local cut-off in ξ space:

$$a(\xi)^2 = (1/\Lambda^2) \exp[-\phi(\xi)] \quad . \quad 8-23$$

Since (8-23) is only valid in a region where $\phi(\xi)$ does not change much over distances of order a , Eq. (8-22) therefore represents a more general (non-linear and non-local) relation between a^2 and $1/\Lambda^2$. Convergence of (8-22) enforces $\mu < 2$. For vortices with $\mu \geq 2$, the proper area diverges for any finite $a(\xi)$ and remains finite only as $a(\xi)$ vanishes strictly. These are precisely the spike degeneration into branched polymers and can be viewed as singular vortices. We thus see that singular vortices or spikes have a minimum amplitude $\mu=2$. Our speculation here is that it is this singular vortex configuration with the minimum amplitude which

plays an important role in determining the subleading behavior of the system. The field energy for this singular vortex is given by

$$U = \frac{1}{2\alpha_r} \int d^2\xi (\partial\phi)^2 = \frac{4\pi}{\alpha_r} \ln(R/a) \quad , \quad 8-24$$

where the cutoff a corresponding to $a(\xi)$ is kept finite and R is the linear size of the system (or an outer cutoff radius on the ϕ field).

(8-14) can be compared with the asymptotic form of the level density [57, 62, 64]:

$$\rho(m) \underset{m \rightarrow \infty}{\sim} cm^{-\kappa+3} \exp(bm) \quad , \quad 8-25$$

where m is related to n through (6-11) and plays the similar role as A in (8-2). Note that $R/a \sim \sqrt{n}$ in (8-24). Adding the contribution from the anomaly (8-24) to the free energy (8-14) and comparing it with (8-25), we find for the open string:

$$\begin{aligned} \kappa &= - \frac{(d-2)(1+1/n_0) - d + 4}{2} - \frac{4\pi}{\alpha(T_H)} + 3 \\ &\approx - \frac{d-2-d+4}{2} - d + 2 + 3 = 4 - d \quad , \end{aligned} \quad 8-26$$

where we have used (6-19) for $\alpha(T_H)$. We see from (8-26) that the marginal case for the open string is $d=4$. That is, the open string

branches like random walks for $d < 3$ at T_H . For closed string, we simply replace $(d-2)$ by $2(d-2)$ in (8-26) to obtain

$$\kappa = - \frac{2(d-2)(1+1/n_0) - d + 4}{2} - \frac{4\pi}{\alpha(T_H)} + 3$$

$$\approx \frac{10-3d}{2} \quad . \quad \quad \quad 8-27$$

The marginal case for the closed string is $d=10/3$. According to Cabibbo and Parisi^[64], the asymptotic behavior (8-26) with $\kappa < 2$ (i.e., $d > 0$) is typical of a second-order phase transition. We conclude from (8-26) and (8-27) that a gas of rigid strings with liquid-crystal-like order in the physical dimension $d=4$ exhibits critical behavior at $T=T_H$.

8.3 THE PHASE DIAGRAM

As mentioned in Chapter 6, the present model contains only one basic scale σ_0 . All quantities such as T_c , T_H , λ_0 and α_0 can be expressed in terms of σ_0 . This makes the phase diagram of the model quite simple. As shown in Fig. 1 (the (σ_0-T) diagram), unlike the Nambu-Goto string and the Polyakov-Kleinert string, there exist

three distinct regions in the present model: The regions (I) and (III) are the smooth with $\nu=1/2$ (or $d_H=2$) and crumpled phases with $\nu=\infty$ (or $d_H=\infty$) respectively while region (II) is a rough phase possibly with continuous changing critical exponent $1/2 \leq \nu \leq 1$ (or $2 \leq d_H \leq 4$). It is interesting to compare our result with that obtained from numerical simulations by Ambjorn, Durhuus and Jonsson^[65] for discretized random surfaces with the topology of a torus with rigidity and fixed connectivity (without self-avoidance). It has been found in ref. [65] that the Hausdorff dimension of the surfaces is a function of the bending rigidity $1/\alpha_0$. For $1/\alpha_0$ sufficiently small the Hausdorff dimension is infinite, but jumps to a value smaller or equal to 4 at a critical value of $1/\alpha_0$ where a crumpling transition is identified and claimed to be second order in nature. For $1/\alpha_0$ above the critical value, their numerical data favour a continuously varying Hausdorff dimension, changing from 4 at the critical value of $1/\alpha_0$ to 2 for $1/\alpha_0$ going to infinity. We thus see that our analytical results

agree with that obtained from numerical simulations in ref. [65].

The main result found in this work is that there exists an intermediate region (II) which separates the smooth phase from the crumpled phase in the model. This differs from that obtained from the Nambu-Goto string [13,54] and the Polyakov-Kleinert string [12,46,55] where no such intermediate region is present and $T_H=T_c$. This can be understood as follows. Up to a critical

temperature $T_c \sim 0.69\sqrt{\sigma_0}$ at which the Nambu-Goto string or the Polyakov-Kleinert string reaches its transition point with the Hausdorff dimension 4 and so branches like random walks, the rigid string with fixed density just overcomes its stiffness and starts to crease with the Hausdorff dimension 2. As the temperature rises further, the string loses its stiffness further and behaves like the Nambu-Goto string as the Hagedorn temperature is reached.

Therefore it could have been expected that $T_H > T_c$.

Finally, we note that from the point of view of strings, the QCD vacuum in the high temperature phase is complicated and nonperturbative. Near the Hagedorn temperature one must expect that small closed strings (or spikes) are likely to be formed due to the relatively chaotic flux tube oscillations, which can burn off small closed strings due to self-touchings or self-crossings. These small closed strings (or spikes) are analogous to the vortices in the

periodic Gaussian model in the high-temperature phase. The crumpled phase then corresponds to a vacuum (nontrivial background) that consists of a condensate of vortices (small closed strings or spikes).

CHAPTER 9

Discussion and Summary

We identify T_c as the deconfinement temperature in QCD. The reason is the following: First, the smooth phase corresponds to the confined phase since both are characterized by a nonvanishing string tension while for $T > T_c$, $\sigma_{\text{eff}} = 0$ which corresponds to the deconfined region in QCD. Moreover, the string model in the smooth phase has a local $SU(\infty)$ symmetry which is known as the area-preserving symmetry existing in the Dirac membranes in the light-cone gauge^[32]. (We here emphasize that in the present model the area-preserving symmetry is a true symmetry of the system in the smooth phase.) The critical temperature T_c associates precisely with the breakdown of this symmetry or its center group $O(2)$ or $U(1)$ which is equivalent to $Z(N_c)$ as N_c to be large, which associates with the deconfinement transition in QCD^[66, 67].

We identify T_H with the chiral transition temperature in QCD. The reason is the following. For $T < T_H$, the system is in the anisotropic region where $O(4)$ symmetry is broken. This resembles the chiral symmetry broken region where the instanton molecules

dominate. Recent analytic calculations^[68] and numerical investigations^[69] have shown that in the broken chiral symmetry region the QCD vacuum consists of an amorphous network of instantons and anti-instantons constantly absorbing and emitting light quarks of different flavors. The amorphous structure leads to a delocalization of fermionic zero modes and to the spontaneous breakdown of chiral symmetry. This picture is consistent with a string in the intermediate region. The crumpled or isotropic phase is the expected phase of quark-gluon plasma. In this phase, the chiral symmetry is restored due to the isotropic orientation of the instanton molecules^[68,69]. (We remind the reader that due to the special property of instantons, the orientation of the instantons in the color space is identical to that in space at least for $SU_c(2)$.) The resemblance becomes closer if we note the following isomorphism:

$$O(4) \sim \frac{SU(2) \times SU(2)}{Z_2} \quad . \quad 8-21$$

This relation perhaps implies that the present model describes effectively QCD with two light quarks (i.e., u and d quarks).

Let us summarize our results. In Chapter 2, we have proposed the model of rigid strings with liquid-crystal-like order and carried out the classical symmetry study of the model. We have shown that the model describes an off-shell generalization of the

theory of minimal surfaces (string worldsheets). The area-preserving symmetry together with the conformal symmetry has been shown to play an important role in the present model.

In Chapter 3, we have carried out a perturbative renormalization of the theory. We have calculated the renormalized bending rigidity which agrees with that of the membranes (with fixed density) [6,35]. We have discussed the geometric meaning of the X-field renormalization.

In Chapter 4, we have presented a generalized (covariant) gauge fixing procedure and solved a set of saddle point equations. A nontrivial saddle point solution of the Lagrange multiplier has been obtained (e.g., (4-37) and (4-38)). We have also calculated the quantum fluctuations of the Lagrange multiplier. It has been found that the fluctuations take the form of conformal anomaly (4-46) which is "frozen" at low temperature.

In Chapter 5, we have discussed the implication of the saddle point solution obtained in Chapter 4 to a finite temperature phase transition of the model. We have calculated the critical temperature, the Hausdorff dimension, and the width of the string. We have shown that there is a smooth-rough transition in the model. The differences of this transition from the roughening transition existing in the s.o.s. model as well as the Z_2 lattice gauge theory have also been discussed.

In Chapter 6, we have estimated the Hagedorn temperature by assuming the irrelevance of the rigidity term due to the vacuum condensate of the Lagrange multiplier. We have found the remarkable result that $T_H \approx (\sqrt{2}) T_c$. We have calculated the mean squared radius of an open string at T_H from which it has been shown that the Hausdorff dimension of the string sheet is 4.

In Chapter 7, we have calculated the path integral and then the free energy of a gas of rigid strings on a torus. The mass spectrum of the closed strings has been obtained from which it has been shown that the theory is free of tachyons. The calculation has also been extended to the open rigid strings.

Finally, in Chapter 8, based on the free energy of a gas of open rigid strings obtained in Chapter 7, we have calculated the Hagedorn temperature more rigorously than in Chapter 6. It has been shown that the result agrees nicely with the estimates in Chapter 6. The phase diagram of the model has been worked out and compared with the numerical result of discretized random surfaces.

In conclusion, we have investigated the phase structure of the model of rigid strings with liquid-crystal-like order in this thesis. An intermediate region (rough phase) separates a smooth phase with infinite correlation length and Hausdorff dimension $d_H=2$ from a crumpled phase with the Hausdorff dimension infinite.

APPENDIX **A**

ζ -Function Evaluation Of $\text{Lndet}'(-\Delta)$ And $\text{Lndet}'(-\Delta+\lambda)$

First consider the operator $-\Delta$ and its real discrete eigenvalues $\{ a_{n,m} \}$, with $n,m = 1,2,\dots$; call its eigenfunctions $f_{n,m}(\xi)$

$$-\Delta f_{n,m}(\xi) = a_{n,m} f_{n,m}(\xi) \quad , \quad \text{A-1}$$

where $\Delta = \partial^2/\rho$. (We drop the subscript ρ on ρ 's for convenience.)

The domain C is defined by

$$C = \{ (\xi^1, \xi^2) \mid 0 \leq \xi^1 \leq R' \} / \sim \quad , \quad \text{A-2-a}$$

where \sim represents the equivalence relation defined by

$$(\xi^1, \xi^2) \sim (\xi^1, 2\beta' + \xi^2) \quad \text{A-2-b}$$

We define a function as follows,

$$\zeta_{-\Delta}(s) = \sum_{n,m=1}^{\infty} \frac{1}{a_{n,m}^s} \quad , \quad \text{A-3}$$

called the ζ -function associated to $-\Delta$. Then the sum extends over all the eigenvalues of $-\Delta$. We note that $-\Delta$ is real and

$$\begin{aligned}\zeta'_{-\Delta}(0) &\equiv \left. \frac{d\zeta_{-\Delta}(s)}{ds} \right|_{s=0} = - \sum_{n,m=1}^{\infty} \ln a_{n,m} e^{-s \ln a_{n,m}} \Big|_{s=0} \\ &= - \ln \left(\prod_{n,m=1}^{\infty} a_{n,m} \right) \quad , \quad \text{A-4}\end{aligned}$$

which leads to

$$\det'(-\Delta) = \prod_{n,m=1}^{\infty} a_{n,m} = e^{-\zeta'_{-\Delta}(0)} \quad , \quad \text{A-5}$$

or

$$\ln \det'(-\Delta) = -\zeta'_{-\Delta}(0) \quad . \quad \text{A-6}$$

We choose the following as the orthonormal basis satisfying (A-1) and (A-2),

$$\begin{aligned}f_{m,o}(\xi) &= \sqrt{\frac{2}{R'\beta'}} \sin\left(\frac{m\pi\xi^1}{R'}\right) \quad , \\ f_{m,n}^1(\xi) &= \sqrt{\frac{4}{R'\beta'}} \sin\left(\frac{m\pi\xi^1}{R'}\right) \cos\left(\frac{2n\pi\xi^2}{\beta'}\right) \quad , \quad (m,n=1,2,\dots) \quad , \\ f_{m,n}^2(\xi) &= \sqrt{\frac{4}{R'\beta'}} \sin\left(\frac{m\pi\xi^1}{R'}\right) \sin\left(\frac{2n\pi\xi^2}{\beta'}\right) \quad , \quad \text{A-7}\end{aligned}$$

The corresponding eigenvalues are therefore,

$$\begin{aligned}a_{m,o} &= \frac{1}{\rho} \left(\frac{m\pi}{R'}\right)^2 \quad \text{for } f_{m,o}(\xi) \quad , \\ a_{m,n} &= \frac{1}{\rho} \left[\left(\frac{m\pi}{R'}\right)^2 + \left(\frac{2n\pi}{\beta'}\right)^2 \right] \quad \text{for } f^1, f^2 \quad . \quad \text{A-8}\end{aligned}$$

If we set

$$R' = \sqrt{\rho} \beta \quad \text{and} \quad \beta' = \beta / \sqrt{\rho} \quad , \quad \text{A-9}$$

the eigenvalues (A-8) become,

$$\begin{aligned} a_{m,0} &= \left(\frac{m\pi}{\rho\beta} \right)^2 && \text{for } f_{m,0}(\xi) \quad , \\ a_{m,n} &= \left[\left(\frac{m\pi}{\rho\beta} \right)^2 + \left(\frac{2n\pi}{\beta} \right)^2 \right] && \text{for } f^1, f^2 \quad . \quad \text{A-10} \end{aligned}$$

Therefore,

$$\begin{aligned} \ln \det' (-\Delta) &= - \frac{d}{ds} \left\{ 2 \sum_{m,n=1}^{\infty} \left[\left(\frac{m\pi}{\rho\beta} \right)^2 + \left(\frac{2n\pi}{\beta} \right)^2 \right]^{-s} \right. \\ &\quad \left. + \sum_{m=1}^{\infty} \left[\left(\frac{m\pi}{\rho\beta} \right)^2 \right]^{-s} \right\} \Big|_{s=0} \quad . \quad \text{A-11} \end{aligned}$$

The partition function is computed for $R \gg T$, that is, $\rho \gg 1$. In this case the sum over m can be replaced by an integral from $-\infty$ to $+\infty$,

$$- \frac{d}{ds} \sum_{m=1}^{\infty} \left[\left(\frac{m\pi}{\rho\beta} \right)^2 \right]^{-s} \Big|_{s=0} = -\rho\beta \frac{d}{ds} \int \frac{d\omega}{2\pi} \frac{1}{\omega^{2s}} \Big|_{s=0} \quad , \quad \text{A-12}$$

and

$$\begin{aligned}
& - \frac{d}{ds} \sum_{m,n=1}^{\infty} \left[\left(\frac{m\pi}{\rho\beta} \right)^2 + \left(\frac{2n\pi}{\beta} \right)^2 \right]^{-s} \Big|_{s=0} \\
& = -\rho\beta \frac{d}{ds} \sum_{n=1}^{\infty} \int \frac{d\omega}{2\pi} \frac{1}{\left[\omega^2 + \left(\frac{2n\pi}{\beta} \right)^2 \right]^s} \Big|_{s=0}
\end{aligned} \tag{A-13}$$

Using the formula

$$\int_{-\infty}^{\infty} \frac{d\omega}{2\pi} \frac{1}{(\omega^2 + a^2)^\beta} = \frac{1}{(4\pi)^{1/2}} \frac{\Gamma(\beta-1)}{\Gamma(\beta)} a^{1-2\beta} \tag{A-14}$$

we find,

$$\begin{aligned}
\text{Indet}'(-\Delta) & = - \frac{2\rho\beta}{(4\pi)^{1/2}} \frac{d}{ds} \frac{\Gamma(s-1/2)}{\Gamma(s)} \sum_{n=1}^{\infty} \left(\frac{\beta}{2n\pi} \right)^2 \Big|_{s=0} \\
& = - \frac{2\rho\beta}{(4\pi)^{1/2}} \frac{d}{ds} \frac{\Gamma(s-1/2)}{\Gamma(s)} \left(\frac{\beta}{2\pi} \right)^{2s-1} \sum_{n=1}^{\infty} \left(\frac{1}{n} \right)^{s-1/2} \Big|_{s=0}
\end{aligned} \tag{A-15}$$

Using the standard Γ -function formulas:

$$\Gamma(s-1/2) = \frac{\Gamma(2s-1)}{\Gamma(s)} \frac{\sqrt{\pi}}{2^{2s-1}} \tag{A-16-a}$$

$$\Gamma(s) = \frac{\pi}{\sin\pi s} \frac{1}{\Gamma(1-s)} \tag{A-16-b}$$

$$\Gamma(2s-1) = - \frac{\pi}{2\sin\pi s \cos\pi s} \frac{1}{\Gamma(2-2s)} \tag{A-16-c}$$

and

$$\frac{\Gamma(s-1/2)}{\Gamma(s)} = \frac{\sqrt{\pi}}{2^{2s-1}} \frac{\Gamma(2s-1)}{\Gamma(s)^2} = -\frac{\sqrt{\pi} \sin \pi s \Gamma^2(1-s)}{\pi 2^{2s-1} \cos \pi s \Gamma(2-2s)} \quad ,$$

A-16-d

we find

$$\text{Indet}'(-\Delta) = 4\pi\rho \sum_{n=1}^{\infty} \left(\frac{1}{2}\right)_n^{s-1/2} \Big|_{s=0} = -\frac{\rho\pi}{3} \quad ,$$

A-17

where we have used the well known result

$$\sum_{n=1}^{\infty} \left(\frac{1}{2}\right)_n^{s-1/2} \Big|_{s=0} = \zeta(-1) = -\frac{1}{12} \quad . \quad \text{A-18}$$

We see that (A-17) agrees with (4-24).

In the same fashion, we can calculate $\text{Indet}'(-\Delta + \lambda)$. (We drop the subscript 0 on λ 's for convenience.) We first introduce a mass scale as follows,

$$\det(-\Delta + \lambda) = \frac{1}{\Lambda^2} \det \left[\frac{1}{\Lambda^2} (-\Delta + \lambda) \right] \quad . \quad \text{A-19}$$

The eigenfunctions are given by (A-7). The corresponding eigenvalues are therefore,

$$a_{m,0} = \frac{1}{\Lambda^2} \left[\left(\frac{m\pi}{\rho\beta} \right)^2 + \lambda \right] ,$$

$$a_{m,n} = \frac{1}{\Lambda^2} \left[\left(\frac{m\pi}{\rho\beta} \right)^2 + \left(\frac{2n\pi}{\beta} \right)^2 + \lambda \right] . \quad \text{A-20}$$

We find, .

$$\begin{aligned} \text{Indet}' \left[\frac{1}{\Lambda^2} (-\Delta + \lambda) \right] &= -\frac{d}{ds} \left\{ 2 \sum_{m,n=1}^{\infty} \left(\frac{1}{\Lambda^2} \right)^{-s} \left[\left(\frac{m\pi}{\rho\beta} \right)^2 + \left(\frac{2n\pi}{\beta} \right)^2 + \lambda \right]^{-s} \right. \\ &\quad \left. + \sum_{m=1}^{\infty} \left(\frac{1}{\Lambda^2} \right)^{-s} \left[\left(\frac{m\pi}{\rho\beta} \right)^2 + \lambda \right]^{-s} \right\} \Big|_{s=0} \\ &= -\rho\beta \frac{d}{ds} \left(\frac{1}{\Lambda^2} \right)^{-s} \left\{ 2 \sum_{n=1}^{\infty} \int \frac{d\omega}{2\pi} \frac{1}{[\omega^2 + \left(\frac{2n\pi}{\beta} \right)^2 + \lambda]^s} \Big|_{s=0} \right. \\ &\quad \left. + \int \frac{d\omega}{2\pi} \frac{1}{(\omega^2 + \lambda)^s} \Big|_{s=0} \right\} \\ &= -\frac{\rho\beta}{(4\pi)^{1/2}} \frac{d}{ds} \left(\frac{1}{\Lambda^2} \right)^{-s} \frac{\Gamma(s-1/2)}{\Gamma(s)} \left\{ 2 \sum_{n=1}^{\infty} \frac{1}{\left[\left(\frac{2n\pi}{\beta} \right)^2 + \lambda \right]^{s-1/2}} \Big|_{s=0} \right. \\ &\quad \left. + \lambda^{1/2-s} \Big|_{s=0} \right\} \end{aligned}$$

$$\begin{aligned}
&= -\frac{\rho\beta}{(4\pi)^{1/2}} \frac{d}{ds} \left(\frac{1}{\Lambda^2}\right)^{-s} \frac{\Gamma(s-1/2)}{\Gamma(s)} \left\{ \sum_{n=-\infty}^{\infty} \frac{1}{\left[\left(\frac{2n\pi}{\beta}\right)^2 + \lambda\right]^{s-1/2}} \right\} \Big|_{s=0} \\
&= -\rho\sqrt{\pi} \frac{d}{ds} \left(\frac{2\pi}{\Lambda\beta}\right)^{-2s} \frac{\Gamma(s-1/2)}{\Gamma(s)} \left\{ \sum_{n=-\infty}^{\infty} \frac{1}{\left[n^2 + \left(\frac{\beta\sqrt{\lambda}}{2\pi}\right)^2\right]^{s-1/2}} \right\} \Big|_{s=0}
\end{aligned}$$

A-21

We now use the Sommerfeld-Watson transformation to convert the sum over n to a contour integral J ,

$$\begin{aligned}
J &= \sum_{n=-\infty}^{\infty} \frac{1}{\left[n^2 + \left(\frac{\beta\sqrt{\lambda}}{2\pi}\right)^2\right]^{s-1/2}} \\
&= \int_C \cot\pi z \frac{dz}{2i} \frac{1}{\left[z+i\left(\frac{\beta\sqrt{\lambda}}{2\pi}\right)\right]^{s-1/2} \left[z-i\left(\frac{\beta\sqrt{\lambda}}{2\pi}\right)\right]^{s-1/2}}
\end{aligned} \tag{A-23}$$

where C is the contour shown in Fig. A-1. Since

$$\begin{aligned}
\cot\pi z &= \frac{\cos\pi z}{\sin\pi z} = \frac{e^{i\pi z}}{\sin\pi z} - i \quad (\text{Im}z > 0) \\
\cot\pi z &= \frac{e^{-i\pi z}}{\sin\pi z} + i \quad (\text{Im}z < 0)
\end{aligned} \tag{A-24}$$

we have,

$$J = J_1 + J_2 + J_3 + J_4$$

where

$$\begin{aligned}
 J_1 &= \int_{\infty+i\epsilon}^{-\infty+i\epsilon} \frac{e^{i\pi z}}{\sin\pi z} \frac{1}{(z+ib)^{s-1/2} (z-ib)^{s-1/2}} \frac{dz}{2i} , \\
 J_2 &= \int_{-\infty-i\epsilon}^{\infty-i\epsilon} \frac{e^{-i\pi z}}{\sin\pi z} \frac{1}{(z+ib)^{s-1/2} (z-ib)^{s-1/2}} \frac{dz}{2i} , \\
 J_3 &= - \int_{\infty+i\epsilon}^{-\infty+i\epsilon} \frac{dz/2}{(z+ib)^{s-1/2} (z-ib)^{s-1/2}} , \\
 J_4 &= \int_{-\infty-i\epsilon}^{\infty-i\epsilon} \frac{dz/2}{(z+ib)^{s-1/2} (z-ib)^{s-1/2}} , \qquad \text{A-26}
 \end{aligned}$$

with $b = \beta\sqrt{\lambda}/2\pi$.

Consider the contour c_1 as shown in Fig. A-2. Since $\oint_{c_1} = 0$, we have

$$J_1 = \int_{\infty+i\epsilon}^{-\infty+i\epsilon} = \int_{c_1} + \int_{c_2} + \int_{c_r} , \qquad \text{A-27}$$

where

$$\left| \int_{c_r} \right| \leq 2\pi r \sqrt{r} \xrightarrow{r \rightarrow 0} 0 \qquad \text{A-28}$$

Setting $z=iy+ib$, $dz=idy$, we have

$$\begin{aligned}
J_1 &= \int_{c_1} + \int_{c_2} = \int_0^{\infty} \frac{e^{-\pi(y+b)}}{\sin i\pi(y+b)} \frac{(-1)^{s-1/2} dy/2}{(y+2b)^{s-1/2} (y_+)^{s-1/2}} \\
&\quad + \int_0^{\infty} \frac{e^{-\pi(y+b)}}{\sin i\pi(y+b)} \frac{(-1)^{1/2-s} dy/2}{(y+2b)^{s-1/2} (y_-)^{s-1/2}} \\
&= \int_0^{\infty} \frac{dy}{2} \frac{e^{-\pi(y+b)}}{i \sinh \pi(y+b)} \frac{(-1)^{1/2-s}}{(y+2b)^{s-1/2}} \left(\frac{1}{Y_-^{s-1/2}} - \frac{1}{Y_+^{s-1/2}} \right) \quad A-29
\end{aligned}$$

Letting $y^- = ye^{i2\pi}$ and $y^+ = y$ gives

$$\begin{aligned}
J_1 &= -2 \int_0^{\infty} \frac{\sin \pi(s-1/2) [y(y+2b)]^{1/2-s} dy}{1 - e^{2\pi(y+b)}} \\
&\xrightarrow{s \rightarrow 0} 2 \int_0^{\infty} \frac{dy}{1 - e^{2\pi(y+b)}} y^{1/2} (y+2b)^{1/2} \quad A-30
\end{aligned}$$

In the same fashion we find

$$J_2 = J_1 \quad , \quad A-31$$

and

$$\begin{aligned}
J_3 = J_4 &= \int_0^{\infty} \frac{dy \sin \pi(s-1/2)}{(y+2b)^{s-1/2} y^{s-1/2}} \\
&= \frac{\sin \pi(s-1/2)}{(2b)^{s-1/2}} \int_0^{\infty} \frac{dy y^{(-s+3/2)-1}}{\left(1 + \frac{y}{2b}\right)^{(-s+3/2)+(2s-2)}} \quad A-32
\end{aligned}$$

Comparing J_3 or J_4 with the following

$$\int_0^{\infty} \frac{dt t^{m-1}}{(1 + At^a)^{m+n}} = a^{-1} A^{-m/a} B\left(\frac{m}{a}, m+n - \frac{m}{a}\right), \quad \text{A-33}$$

we find

$$a = 1, \quad A = 1/2b, \quad m = -s+3/2, \quad n = 2s-2 \quad \text{A-34}$$

Therefore,

$$\begin{aligned} J_3 + J_4 &= \frac{2\sin\pi(s-1/2)}{(2b)^{2s-2}} B(-s+3/2, 2s-2) \\ &= \frac{2\sin\pi(s-1/2)}{(2b)^{2s-2}} \frac{\Gamma(-s+3/2)\Gamma(2s-2)}{\Gamma(s-1/2)}. \end{aligned} \quad \text{A-35}$$

Using

$$\Gamma(2s-2) = \frac{\pi}{\sin\pi(2s-2)\Gamma(3-2s)}$$

and

$$\Gamma(s-1/2) = \frac{\pi}{\sin\pi(s-1/2)\Gamma(3/2-s)}$$

(A-35) becomes,

$$\begin{aligned} J_3 + J_4 &= \frac{2\sin\pi(s-1/2)}{(2b)^{2s-2}} \frac{\sin\pi(s-1/2)}{\sin\pi(2s-2)} \frac{\Gamma^2(3/2-s)}{\Gamma(3-2s)} \\ &= (2b)^{2-2s} \frac{\cos\pi s}{\sin\pi s} \frac{\Gamma^2(3/2-s)}{\Gamma(3-2s)}. \end{aligned} \quad \text{A-36}$$

Gathering all these pieces gives,

$$\begin{aligned}
J &= -4\sin\pi(s-1/2) \int_0^{\infty} \frac{dy [(y+2b)y]^{1/2-s}}{1 - e^{2\pi(y+b)}} \\
&\quad + (2b)^{2-2s} \frac{\cos\pi s}{\sin\pi s} \frac{\Gamma^2(3/2-s)}{\Gamma(3-2s)} \quad . \quad \text{A-37}
\end{aligned}$$

And therefore,

$$\begin{aligned}
&\text{Indet}' \left[\frac{1}{\Lambda^2} (-\Delta + \lambda) \right] \\
&= \rho \sqrt{\pi} \frac{d}{ds} \left(\frac{2\pi}{\Lambda\beta} \right)^{-2s} \frac{\Gamma^2(s-1/2)}{\Gamma(s)} \\
&\quad \times \left[\sin\pi(s-1/2) I(b) + (2b)^{2-2s} \frac{\cos\pi s}{\sin\pi s} \frac{\Gamma^2(3/2-s)}{\Gamma(3-2s)} \right] \Big|_{s=0} \\
&= \rho \sqrt{\pi} \frac{d}{ds} \left(\frac{2\pi}{\Lambda\beta} \right)^{-2s} \frac{\sqrt{\pi} \sin\pi s \Gamma^2(1-s)}{\pi 2^{2s-1} \cos\pi s \Gamma(2-2s)} \\
&\quad \times \left[\cos\pi s I(b) + (2b)^{2-2s} \frac{\cos\pi s}{\sin\pi s} \frac{\Gamma^2(3/2-s)}{\Gamma(3-2s)} \right] \Big|_{s=0} \quad \text{A-38}
\end{aligned}$$

Using

$$\Gamma(2-2s) = \frac{2^{2(1-s)-1}}{\sqrt{\pi}} \Gamma(1-s) \Gamma(3/2-s) \quad ,$$

$$\Gamma(3-2s) = (2-2s) \Gamma(2-2s) \quad ,$$

and

$$\begin{aligned}
\frac{\Gamma^2(1-s)}{\Gamma(2-2s)} \frac{\Gamma^2(3/2-s)}{\Gamma(3-2s)} &= \frac{\Gamma^2(1-s)\Gamma^2(3/2-s)}{(2-2s)\Gamma^2(2-2s)} \\
&= \frac{\pi\Gamma^2(1-s)\Gamma^2(3/2-s)}{(2-2s)2^{2[2(1-s)-1]}\Gamma^2(1-s)\Gamma^2(3/2-s)} \\
&= \frac{\pi}{(2-2s)2^{2(1-2s)}} \quad ,
\end{aligned}$$

we finally get,

$$\begin{aligned}
\text{Indet}' \left[\frac{1}{\Lambda^2}(-\Delta + \lambda) \right] &= 2\pi\rho I(b) + 2\pi\rho b^2 \frac{d}{ds} \left(\frac{2\pi b}{\Lambda\beta} \right)^{-2s} \frac{1}{2-2s} \Big|_{s=0} \\
&= 2\pi\rho I(b) + \frac{\rho\lambda\beta^2}{2\pi} \frac{d}{ds} \left(\frac{\lambda^{1/2}}{\Lambda} \right)^{-2s} \frac{1}{2-2s} \Big|_{s=0} \\
&= 2\pi\rho I(b) + \frac{\rho\lambda\beta^2}{4\pi} \left(\ln \frac{\Lambda^2}{\lambda} + 1 \right) \quad , \quad \text{A-39}
\end{aligned}$$

where $I(b)$ is defined by

$$I(b) = 4 \int_0^{\infty} \frac{dy}{1 - e^{\frac{2\pi(y+b)}{\Lambda}}} Y^{1/2} (y+2b)^{1/2} \quad , \quad \text{A-40}$$

with $b = \beta\sqrt{\lambda}/2\pi$. We immediately see that (A-39) and (A-40) agree with (4-27)-(4-29).

APPENDIX **B**

ζ -Function Evaluation Of $\text{Lndet}'(-\Delta/\lambda+1)$ On A Torus

In this Appendix we wish to evaluate $\text{Lndet}'(-\Delta/\lambda+1)$ on a torus.

For a torus, the metric and its inverse are given by

$$g_{ab} = \begin{pmatrix} 1 & \tau_1 \\ \tau_1 & |\tau|^2 \end{pmatrix} \quad \text{and} \quad g^{ab} = \begin{pmatrix} |\tau|^2 & -\tau_1 \\ -\tau_1 & 1 \end{pmatrix} . \quad \text{B-1}$$

The Laplatian is

$$\begin{aligned} \Delta &= \frac{1}{\sqrt{g}} \partial_a \sqrt{g} g^{ab} \partial_b = g^{ab} \partial_a \partial_b \\ &= \frac{1}{\tau_2^2} \{ |\tau|^2 \partial_1^2 + \partial_2^2 - 2\tau_1 \partial_1 \partial_2 \} \quad , \quad \text{B-2} \end{aligned}$$

and the eigenfunctions are

$$f_{m,n}(\xi) = \exp \left\{ \frac{2\pi i}{\beta} (m\xi^1 + n\xi^2) \right\} . \quad \text{B-3}$$

We introduce a mass scale Λ as follows,

$$\det'(-\Delta/\lambda+1) = \frac{\lambda}{\Lambda^2} \det' \left[\frac{1}{\Lambda^2} (-\Delta + \lambda) \right] .$$

Therefore,

$$\begin{aligned}
& \det' \left[\frac{1}{\Lambda^2} (-\Delta + \lambda) \right] \\
&= \det' \left\{ -\frac{1}{\Lambda^2 \tau_2^2} \left[(\tau_1^2 + \tau_2^2) \partial_1^2 + \partial_2^2 - 2\tau_1 \partial_1 \partial_2 + \tau_2^2 \lambda \right] \right\} \\
&= \prod'_{m,n} \frac{4\pi^2}{\Lambda^2 \tau_2^2 \beta^2} \left\{ m^2 \tau_2^2 + (n - m\tau_1)^2 + \frac{\lambda \beta^2 \tau_2^2}{4\pi^2} \right\} , \quad \text{B-4}
\end{aligned}$$

and

$$\ln \det' \left[\frac{1}{\Lambda^2} (-\Delta + \lambda) \right] = \sum'_{m,n} \ln \left\{ \frac{4\pi^2}{\Lambda^2 \tau_2^2 \beta^2} \left[m^2 \tau_2^2 + (n - m\tau_1)^2 + \frac{\lambda \beta^2 \tau_2^2}{4\pi^2} \right] \right\} .$$

B-5

We use the ζ -function regularization to find the finite part of $\ln \det' (-\Delta + \lambda)$ without additional subtraction. Similar to (A-6), we have,

$$\ln \det' \left[(-\Delta + \lambda) / \Lambda^2 \right] = -\zeta'_{(-\Delta + \lambda) / \Lambda^2}(0) , \quad \text{B-6}$$

where $\zeta_{-\Delta + \lambda}(s)$ is called the zeta function associated to $-\Delta + \lambda$ (see (A-3) for definition). Therefore,

$$\begin{aligned}
& \ln \det' \left[\frac{1}{\Lambda^2} (-\Delta + \lambda) \right] \\
&= -\lim_{s \rightarrow 0} \frac{d}{ds} \sum'_{m,n} \left\{ \frac{4\pi^2}{\Lambda^2 \tau_2^2 \beta^2} \left[m^2 \tau_2^2 + (n - m\tau_1)^2 + \frac{\lambda \beta^2 \tau_2^2}{4\pi^2} \right] \right\}^{-s} .
\end{aligned}$$

B-7

The sum over n is converted into an contour integral using the Sommerfeld-Watson transformation (see (A-23)-(A-26)),

$$\begin{aligned}
& \text{Indet}' \left[\frac{1}{\Lambda^2} (-\Delta + \lambda) \right] \\
&= -\lim_{s \rightarrow 0} \frac{d}{ds} \left\{ \left(\frac{4\pi^2}{\Lambda^2 \tau_2^2 \beta^2} \right)^{-s} \int_c dz \sum_m \frac{e^{i\pi z}}{2i \sin \pi z} \left[m^2 \tau_2^2 + (z - m\tau_1)^2 \right. \right. \\
&\quad \left. \left. + \frac{a^2 \tau_2^2}{4\pi^2} \right]^{-s} + \text{h.c.} \right\} \\
&+ \lim_{s \rightarrow 0} \frac{d}{ds} \left\{ \left(\frac{4\pi^2}{\Lambda^2 \tau_2^2 \beta^2} \right)^{-s} \int_c \frac{dz}{2} \sum_m \left[m^2 \tau_2^2 + (z - m\tau_1)^2 \right. \right. \\
&\quad \left. \left. + \frac{a^2 \tau_2^2}{4\pi^2} \right]^{-s} + \text{h.c.} \right\} - \ln \frac{\lambda}{\Lambda^2} \quad ,
\end{aligned}$$

B-8

where $a^2 = \lambda \beta^2$ and the contour c passes above the real axis, from $\infty + i\epsilon$ to $-\infty - i\epsilon$ (see Fig. A-1). The first term in brackets converges at $s = 0$. We first consider

$$\begin{aligned}
& -\lim_{s \rightarrow 0} \frac{d}{ds} \int_{\infty + i\epsilon}^{-\infty + i\epsilon} \frac{dz}{2i} \frac{e^{i\pi z}}{\sin \pi z} \left[m^2 \tau_2^2 + (z - m\tau_1)^2 + \frac{a^2 \tau_2^2}{4\pi^2} \right]^{-s} \\
&= \int_{\infty + i\epsilon}^{-\infty + i\epsilon} \frac{dz}{2i} \frac{e^{i\pi z}}{\sin \pi z} \ln \left[m^2 \tau_2^2 + (z - m\tau_1)^2 + \frac{a^2 \tau_2^2}{4\pi^2} \right] \quad .
\end{aligned}$$

B-9

From

$$m^2 \tau_2^2 + (z - m\tau_1)^2 + \frac{a^2 \tau_2^2}{4\pi^2} = 0 \quad ,$$

we have

$$z = w_{\pm} \quad ,$$

with

$$w_{\pm} = m\tau_1 \pm i\tau_2 \sqrt{m^2 + \frac{a^2}{4\pi^2}} \quad . \quad \text{B-10}$$

Consider the contour c as shown in Fig. B-1. we have

$$\int_{\infty+i\epsilon}^{-\infty+i\epsilon} = \int_{c_1} + \int_{c_2} + \int_{c_r} \quad ,$$

where

$$\left| \int_{c_r} \right| \leq 2\pi r \xrightarrow{r \rightarrow 0} 0 \quad .$$

Setting $z = w_+ + iy$, $dz = idy$, we have

$$\begin{aligned} \text{(B-9)} &= \int_{\infty}^{\circ} \frac{id y}{2i} \frac{e^{i\pi(iy + w_+)}}{\sin\pi(iy + w_+)} [\ln(iy + \delta) - \ln(iy - \delta)] \\ &= \int_{\circ}^{\infty} \frac{-dy}{2} \frac{e^{i\pi(iy + w_+)}}{\sin\pi(iy + w_+)} (2\pi i) \\ &= \ln(1 - e^{2\pi i w_+}) \quad . \quad \text{B-11} \end{aligned}$$

Note that, for $m > 0$,

$$w_+ = |m|\tau_1 + i\tau_2\sqrt{m^2 + a^2/4\pi^2}, \quad w_- = |m|\tau_1 - i\tau_2\sqrt{m^2 + a^2/4\pi^2};$$

and for $m < 0$,

$$\begin{aligned} w_+ &= -|m|\tau_1 + i\tau_2\sqrt{m^2 + a^2/4\pi^2} & w_- &= -|m|\tau_1 - i\tau_2\sqrt{m^2 + a^2/4\pi^2} \\ &= -w_-(m>0), & &= -w_+(m>0). \end{aligned}$$

Therefore the first term on the RHS of (B-8) becomes,

$$2 \sum_m \ln(1 - e^{2\pi i w_+}) = 2 \sum_{m=1}^{\infty} \ln|1 - e^{2\pi i w_+}|^2 + 2 \ln(1 - e^{-\tau_2 a}).$$

B-12

The factor 2 in front of each term is due to the fact that the same contribution comes from the hermission conjugate.

The second term in the r.h.s. of (B-8) converges for $s > 1$. It can be evaluated in the same fashion leading to (B-12), we find

$$\lim_{s \rightarrow 0} \frac{d}{ds} \left(\frac{4\pi^2}{\Lambda^2 \tau_2^2 \beta^2} \right)^{-s} \frac{\sin \pi s}{\cos \pi s} \frac{\Gamma^2(1-s)}{\Gamma(2-2s)} (2\tau_2)^{1-2s} \sum_m \frac{1}{\left(m^2 + \frac{a^2}{4\pi^2}\right)^{s-1/2}}.$$

B-13

We have to use the Sommerfeld-Watson transformation once again to convert the sum over m in (B-13) to an integral. This has been done in Appendix A and is given by (A-23)-(A-37). Combining (B-12), (B-13) and (A-37) gives the final result

$$\begin{aligned}
\text{Indet}'(-\Delta/\lambda + 1) &= \ln \frac{\lambda}{\Lambda^2} + \text{Indet}'\left[\frac{1}{\Lambda^2}(-\Delta + \lambda)\right] \\
&= 2 \sum_{m=1}^{\infty} \ln \left| 1 - e^{2\pi i w_m} \right|^2 + \frac{a^2 \tau_2}{4\pi} \left(1 + \ln \frac{\Lambda^2}{\lambda}\right) \\
&\quad + 8\pi \tau_2 \int_0^{\infty} \frac{dy}{1 - e^{2\pi(y+a/2\pi)}} y^{1/2} (y + a/\pi)^{1/2} \\
&\quad + 2 \ln(1 - e^{-\tau_2 a}) \quad , \quad \text{B-14}
\end{aligned}$$

with $a^2 = \lambda\beta^2$. We see that (B-14) agrees with (7-34).

APPENDIX C

A Derivation of (7-63)

We now evaluate $\det'(-\Delta/\lambda+1)|_C$. The spectrum of the operator $(-\Delta/\lambda+1)$ on a cylinder is the same as that on the torus with τ restricted to $\tau = i\tau_2$. The ζ -function associated with $(-\Delta/\lambda+1)$ can be written as

$$\zeta_{C/(-\Delta/\lambda+1)}(\lambda, s) = \sum_{n,m}' d_C(a_{m,n}) a_{m,n}^{-s}(\lambda) \quad C-1$$

where $a_{m,n}$ denote the allowed eigenvalues of the operator and $d_C(a_{m,n})$ is the degeneracy of the level (m,n) .

The degeneracies are just the number of eigenfunctions even under the involution f_C defined by (7-52). The eigenfunctions are given by (B-3):

$$f_{m,n}(\xi^1, \xi^2) = \exp \frac{2\pi i}{\beta} (m\xi^1 + n\xi^2) \quad C-2$$

Under the involution of f_C (e.g., (7-52)), we have

$$\begin{aligned}
f_{m,n}[f_c(\xi^1, \xi^2)] &= \exp\frac{2\pi i}{\beta}(-m\xi^1 + n\xi^2) \exp 2\pi i m \\
&= f_{-m,n}(\xi^1, \xi^2) \quad .
\end{aligned}
\tag{C-3}$$

So the eigenfunctions that diagonalize f_c are

$$g_{m,n} = \frac{1}{\sqrt{2}} (f_{m,n} + f_{-m,n}) \quad .
\tag{C-4}$$

It is easy to check

$$g_{m,n}[f_c(\xi^1, \xi^2)] = \pm g_{m,n}(\xi^1, \xi^2) \quad .
\tag{C-5}$$

Clearly, if $m \neq 0$, then

$$d_c(a_{m,n}) = \frac{1}{2} d_T(a_{m,n}) \quad .
\tag{C-6}$$

If $m = 0$, then

$$d_c(a_{0,n}) = d_T(a_{0,n}) \quad .
\tag{C-7}$$

Therefore,

$$\begin{aligned}
\zeta_{c/-\Delta\lambda+1}(\lambda, s) &= \frac{1}{2} \sum'_{m,n} d_T(a_{m,n}) a_{m,n}^{-s}(\lambda) + \frac{1}{2} \sum_n a_{0,n}^{-s}(\lambda) \\
&= \frac{1}{2} \zeta_{T/-\Delta\lambda+1}(\lambda, s) + \frac{1}{2} \sum_n \left(\frac{4\pi^2}{\Lambda^2 \beta^2 \tau_2^2} \right)^{-s} \left(n^2 + \frac{\lambda \beta^2 \tau_2^2}{4\pi^2} \right)^{-s} ,
\end{aligned}$$

C-8

and

$$\begin{aligned} \ln \det' (-\Delta/\lambda + 1) |_{\text{C}} &= -\lim_{s \rightarrow 0} \frac{d}{ds} \zeta_{\text{C}/-\Delta/\lambda + 1}(\lambda, s) \\ &= -\zeta'_{\text{C}/-\Delta/\lambda + 1}(\lambda, 0) \end{aligned} \quad , \quad \text{C-9}$$

where

$$\begin{aligned} \zeta'_{\text{C}/-\Delta/\lambda + 1}(\lambda, 0) &= \frac{1}{2} \zeta'_{\text{T}/-\Delta/\lambda + 1}(\lambda, 0) \\ &+ \frac{1}{2} \lim_{s \rightarrow 0} \sum_n \left(\frac{4\pi^2}{\Lambda^2 \beta^2 \tau_2^2} \right)^{-s} \left(n^2 + \frac{\lambda \beta^2 \tau_2^2}{4\pi^2} \right)^{-s} \end{aligned} \quad \text{C-10}$$

The first term in the r.h.s. of (C-10) is evaluated in Appendix B (see B-14). The second term is just the $m=0$ part of the first one.

From (B-12) and (B-13), we find

$$\begin{aligned} \frac{1}{2} \lim_{s \rightarrow 0} \sum_n \left(\frac{4\pi^2}{\Lambda^2 \beta^2 \tau_2^2} \right)^{-s} \left(n^2 + \frac{\lambda \beta^2 \tau_2^2}{4\pi^2} \right)^{-s} \\ = -\ln(1 - e^{-\tau_2 a}) - \ln e^{\tau_2 a} \end{aligned} \quad , \quad \text{C-11}$$

where

$$a^2 = \lambda \beta^2 \quad . \quad \text{C-12}$$

Combining (C-9)-(C-12) gives

$$\det' (-\Delta/\lambda + 1) |_{\text{C}} = (1 - e^{-\tau_2 a}) e^{\tau_2 a} (\det' (-\Delta/\lambda + 1) |_{\text{T}})^{1/2} \quad , \quad \text{C-13}$$

where $\det'(-\Delta\lambda+1)|_T$ is given by (B-14). (C-13) is just (7-63).

FIGURE CAPTIONS

FIG. 1. A sketch of phase diagram for the model. The regions (I) (III) are the smooth and crumpled phases respectively while the region (II) is a crossover.

FIG. A-1 The contour C .

FIG. A-2 The contour C_1 .

FIG. B-1 The contour C .

References

- [1] J. Ambjorn, B. Durhuus, and J. Frohlich, Nucl. Phys. B257, [FS14] (1985) 433
- [2] A.M. Polyakov, Phys. Lett. B103, (1981) 207
- [3] A.M. Polyakov, Mod. Phys. Lett. A2, (1987) 893; V.G. Knizhnik, A.M. Polyakov, and A.B. Zomolodchikov, Mod. Phys. Lett. A3, (1988) 819
- [4] A.M. Polyakov, Nucl. Phys. B268, (1986) 406
- [5] H. Kleinert, Phys. Lett. B174, (1986) 335
- [6] W. Helfrich, Z. Naturforsch C28, (1973) 693; J. Phys. (Paris) 46, (1985) 1263
- [7] J. Ambjorn, B. Durhuus, and T. Jonsson, Phys. Rev. Lett. 58, (1987) 2619; J. Ambjorn, and B. Durhuus, Phys. Lett. B188, (1987) 253; J. Ambjorn, B. Durhuus, J. Frohlich, and T. Jonsson, Nucl. Phys. B290, [FS20] (1987) 480
- [8] Zhou Xiaoan, to be published in Phys. Rev. D41, (1990)
- [9] P.B. Wiegmann, Nucl. Phys. B323, (1989) 311; 330
- [10] D. Forster, Phys. Lett. A114, (1986) 115; L. Peliti, and S. Leibler, Phys. Rev. Lett. 54, (1985) 690; H. Kleinert, Phys. Lett. A114, (1986) 115; L. Peliti, Physica A140, (1986) 269
- [11] A.M. Polyakov, Phys. Lett. B59, (1975) 79
- [12] G. German and H. Kleinert, Phys. Lett. B225, (1989) 107

- [13] R.D. Pisarski, and O. Alvarez, Phys. Rev. D26, (1982) 3735
- [14] F. David, and E. Gitter, Nucl. Phys. B295, (1988) 332;
Europhys. Lett. 3, (1987) 1169
- [15] S. Ami and H. Kleinert, Phys. Lett. A120, (1987) 207
- [16] D.R. Nelson and L. Peliti, J. Physique 48, (1987) 1085; see
also F. David, E. Gitter, and L. Peliti, J. Physique 48,
(1987) 2059; L. Peliti, and J. Prost, J. Phys. (France) 50,
(1989) 1557
- [17] F. David, and E. Gitter, Europhys. Lett. 5, (1988) 709
- [18] M. Paczuski, M. Kardar, and D.R. Nelson, Phys. Rev. Lett. 60,
(1988) 2638
- [19] W. Helfrich, J. de Phys. 47, (1986) 322; *ibid.* 48, (1987) 285
- [20] D. Forster, Europhys. Lett. 4, (1987) 65
- [21] F. David, Europhys. Lett. 6, (1988) 603; See also: H.
Kleinert, J. Stat. Phys. 56, (1989) 227
- [22] Kichoon Yang, Complete and compact minimal surfaces, Kluwer
Academic Publishers (1989); D.A. Hoffman and R. Osserman, J.
Diff. Geom. 18, (1983) 733; Proc. Lond. Math. Soc. 50, (1985)
27
- [23] H.B. Nielsen, and P. Olesen, Nucl. Phys. B61, (1973) 45
- [24] M. Luscher, K. Symanzik, and P. Weisz, Nucl. Phys. B173,
(1980) 365; M. Luscher, G. Munster, and P. Weisz, Nucl. Phys.
B180 [FS2] (1981) 1; M. Luscher, Nucl. Phys. B180 [FS2]

(1981) 317

- [25] N.D. Mermin, and H. Wagner, *Phys. Rev. Lett.* 17, (1966) 1133;
S. Coleman, *Comm. Math. Phys.* 31, (1973) 259
- [26] P.D. Pisarski, *Phys. Rev.* D28, (1983) 2547
- [27] Y.S. Myung, S.H. Yi, and Nguyen Suan Han, *Int. J. of Mod. Phys.* A3, (1988) 2315
- [28] V.V. Nesterenko and Nguyen Suan Han, *Int. J. of Mod. Phys.* A3, (1988) 2315
- [29] S. Ichinose, *Nucl. Phys.* B311, (1988/89) 313; T.L. Curtright, C.I. Ghandour, and C.K. Zachos, *Phys. Rev.* D34, (1986) 3811
- [30] M. Carfora, M. Martellini, A. Marzuoli and R. Silvotti, *Z Phys.* C35 (Germany), (1987) 201; K.S. Viswanathan, R. Parthasarathy and Daniel Kay, *Generalized Gauss map and the geometry of strings*, SFU preprint, (1990)
- [31] P.D. Pisarski, *Phys. Rev.* D38, (1988) 578; *Phys. Rev. Lett.* 58, (1987) 1300; 58(E), (1987) 2608
- [32] P.A.M. Dirac, *Proc. R. Soc.* A268, (1962) 57; *ibid.* A270, (1962) 354; T.A. Arakelyan, and G. K. Savvidy, *Phys. Lett.* B214, (1988) 350; *ibid.* B223, (1989) 41; E.G. Floratos, and J. Iliopoulos, *Phys. Lett.* B201, (1988) 237; I. Bares, C.N. Pope, and E. Sezgin, *Phys. Lett.* B210, (1988) 85; C.N. Pope, and K.S. Stelle, *Phys. Lett.* B226, (1989) 257
- [33] Mark A. Peterson, *J. Math. Phys.* 26, (1985) 711

- [34] W. Helfrich, *Z. Naturforsch* C30, (1975) 841; W. Helfrich, and R.H. Servuss, *Nuovo Cimento* D2, (1984) 137
- [35] A.M. Polyakov, *Gauge Fields and Strings*, Harwood Academic Publishers, (1987)
- [36] Zhou Xiaoan, *Phys. Rev.* D41, (1990) 2634
- [37] J. Polchinski, *Comm. Math. Phys.* 104, (1986) 37
- [38] K.S. Viswanathan and Zhou Xiaoan, *Phys. Rev.* D37, (1988) 974
- [39] K.S. Viswanathan and Zhou Xiaoan, *Phys. Lett.* B202, (1988) 217
- [40] M. Minami, *Prog. Theor. Phys.* 59, (1978) 321
- [41] O. Alvarez, *Phys. Rev.* D24, (1981) 440
- [42] E. Braaten, P.D. Pisarski, and S.-M. Tse, *Phys. Rev. Lett.* 58, (1987) 93; H. Kleinert, *Phys. Rev. Lett.* 58, (1987) 1915; *Phys. Lett.* B197, (1987) 351; P. Olesen, and Sung-Kil Yang, *Nucl. Phys.* B283, (1987) 73; E. Bagan, *Phys. Lett.* B192, (1987) 420; E. Braaten and S.-M. Tse, *Phys. Rev.* D36, (1987) 3102; K.S. Viswanathan, and Zhou Xiaoan, *Int. J. of Mod. Phys.* A4, (1988) 2195
- [43] Zhou Xiaoan, *Phys. Lett.* B238, (1990) 205
- [44] A. Dhar, in *DST Workshop on Particle Physics-Superstring Theory*, Indian Institute of Technology, Kanpur (1987), World Scientific Publishing (1988)
- [45] S.G. Brush, *Rev. Mod. Phys.* 39, (1967) 883; M. Plischke, and

- B. Bergersen, *Equilibrium Statistical Physics*, Prentice-Hall, Englewood Cliffs, New Jersey 07632 (1989)
- [46] S.-M. Tse, *Phys. Rev. D*37, (1988) 2337; H. Kleinert, *Phys. Lett. B*189, (1987) 187; *Phys. Rev. D*40, (1989) 473; G. German, and H. Kleinert, *Phys. Lett. B*220, (1989) 133
- [47] D.J. Gross, *Phys. Lett. B*138, (1984) 185; J. Jurkiewicz, and A. Krzywicki, *Phys. Lett. B*148, (1984) 148
- [48] J.F. Arvis, *Phys. Lett. B*127, (1983) 106; P. Olesen, *Phys. Lett. B*160, (1985) 144; *Nucl. Phys. B*267, (1986) 539; Mingshen Gao, *Phys. Rev. D*40, (1989) 2708
- [49] H.W.J. Blote, J.L. Cardy, and M.P. Nightingale, *Phys. Rev. Lett.* 56, (1986) 742; Ian Affleck, *Phys. Rev. Lett.* 56, (1986) 746
- [50] J. Frohlich, and T. Spencer, *Comm. Math. Phys.* 81, (1981) 527
- [51] F. Wagner, *J. Math. Phys.* 12, (1971) 2259; J.D. Weeks, G.H. Gilmer, and H.J. Leamy, *Phys. Rev. Lett.* 31, (1973) 549; R. Balian, C. Itzykson, and J.M. Drouffe, *Phys. Rev. D*11, (1975) 2098
- [52] G.H. Hardy and S. Ramanujan, *Proc. London Math. Soc.* 17, (1918) 75; Huang and Weinberg, *Phys. Rev. Lett.* 25, (1970) 895;
- [53] R. Hagedorn, *Nuovo Cimento Suppl.* 3, (1965) 147
- [54] B. Sathiapalan, *Phys. Rev. D*35, (1987) 3277; J.J. Atick and

- E. Witten, Nucl. Phys. B310, (1988) 291; G. Chapline and F.R. Klinkhamer, Mod. Phys. Lett. A4, (1989) 1063
- [55] Zhou Xiaolan and K.S. Viswanathan, Mod. Phys. Lett. A4, (1989) 99
- [56] A.B. Zamolodchikov, Phys. Lett. B117, (1982) 87; S. Chaudhuri, H. Kawai, and S.H. Henry Tye, Phys. Rev. D36, (1987) 1148
- [57] M.B. Green, J.H. Schwarz and E. Witten, "Superstring Theory" Cambridge University Press (1987)
- [58] D. Mitchell and N. Turok, Nucl. Phys. B294, (1987) 1138
- [59] I. Antoniadis, C.P. Bachas and C. Kounnas, Nucl. Phys. B289, (1987) 87
- [60] C.P. Burgess and T.R. Morris, Nucl. Phys. B291, (1987) 256
- [61] B. Durhuus, J. Frohlich, and T. Jonsson, Nucl. Phys. B240, (1984) 453
- [62] B. McClain and B.d.b. Rath, Commu. Math. Phys. 111, (1987) 539
- [63] S.G. Rajeev, Phys. Lett. B113, (1982) 146; D. Forster, Nucl. Phys. B283 (1987) 669; M.E. Cates, Europhys. Lett. 8, (1988) 719; D. Johnston, Phys. Rev. D40, (1989) 3402; A. Krzywicki, Phys. Rev. D41, (1990) 3086
- [64] N. Cabibbo and G. Parisi, Phys. Lett. B59, (1975) 67; See also: M.J. Bowick and L.C.R. Wijewardhana, Phys. Rev. Lett.

- 54, (1985) 2485; S.H. Henry Tye, Phys. Lett. B158, (1985) 388; B. Sundborg, Nucl. Phys. B254, (1985) 583; E. Alvarez, Phys. Rev. D31, (1985) 418; K.H. O'Brien and C-I Tan, Phys. Rev. D36, (1987) 1184; M. Axenides and S.D. Ellis, preprint UCB-PTH-87/27 LBL-2364
- [65] J. Ambjorn, B. Durhuus, and T. Jonsson, Nucl. Phys. B316, (1989) 1759
- [66] A.M. Polyakov, Phys. Lett. B72, (1978) 477; L. Susskind, Phys. Rev. D20, (1979) 2610; Yaffe, Rev. Mod. Phys. 53, (1981) 431; L.G. Yaffe, and B. Svetitsky, Phys. Rev. D26, (1982) 963; L.D. McLarran, and B. Svetitsky, Phys. Rev. D24, (1981) 450
- [67] P. Bacilieri et al., Phys. Rev. Lett. 61, (1988) 1545
- [68] D.I. Diakonov and V. Yu Petrov, Nucl. Phys. B245, (1984) 259; Nucl. Phys. B272, (1986) 457; M.A. Nowak, J.J.M. Verbaarschot and I. Zahed, Phys. Lett. B228, (1989) 251
- [69] E.V. Shuryak, Nucl. Phys. B302, (1988) 574; M.A. Nowak, J.J.M. Verbaarschot and I. Zahed, Nucl. Phys. B324, (1989) 1

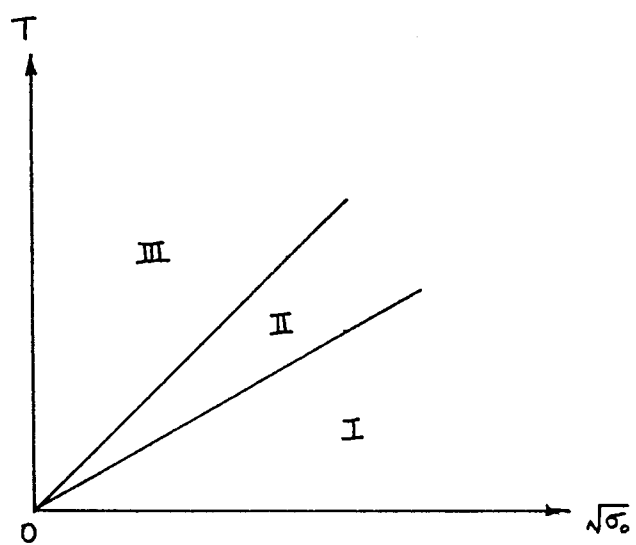

Fig. 1

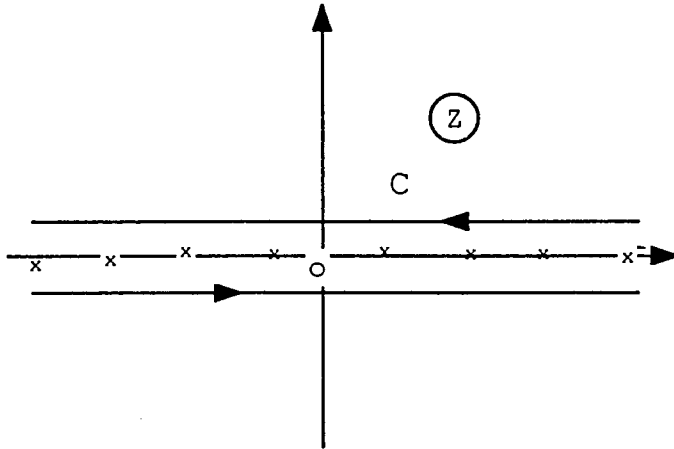

Fig. A-1. The contour C .

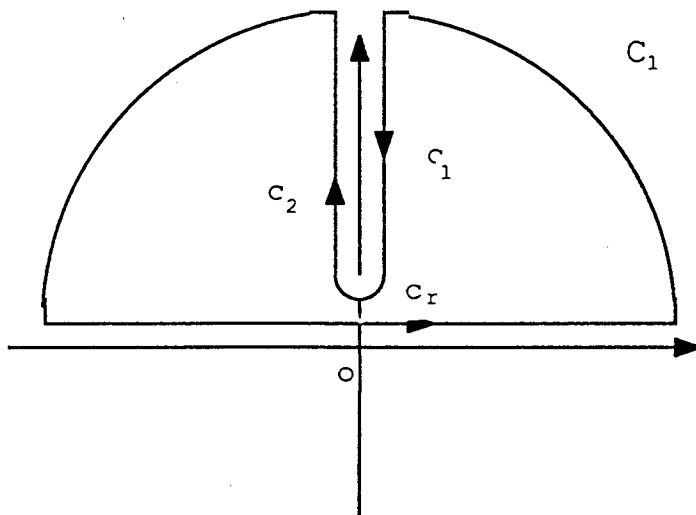

Fig. A-2. The contour C_1 .

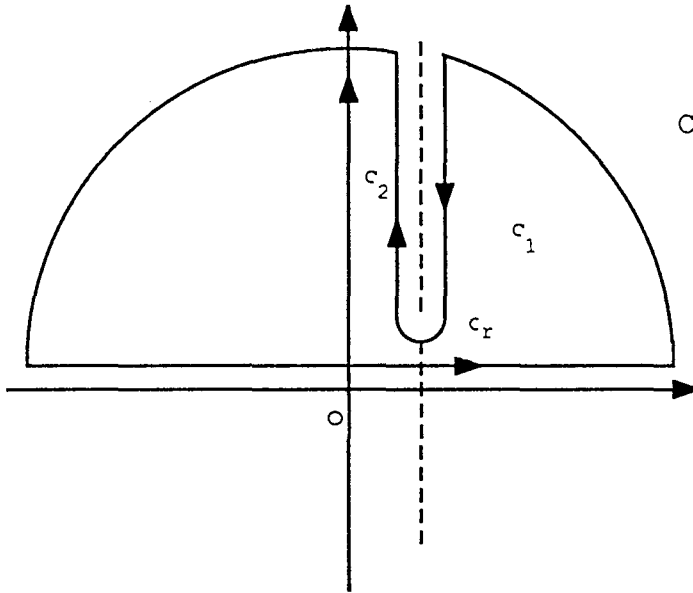

Fig. B-1. The contour C .