

The Enduring Ephemeral, or the Future Is a Memory

Wendy Hui Kyong Chun

Final version published in *Critical Inquiry* 35 (Autumn 2008). 148-171.

New media, like the computer technology on which it relies, races simultaneously towards the future and the past, towards what we might call the bleeding edge of obsolescence. Indeed, rather than asking, What is new media? we might want to ask what seem to be the more important questions: what was new media? and what will it be? To some extent the phenomenon stems from the modifier *new*: to call something new is to ensure that it will one day be old. The slipperiness of new media—the difficulty of engaging it in the present—is also linked to the speed of its dissemination. Neither the aging nor the speed of the digital, however, explains how or why it has become the new or why the yesterday and tomorrow of new media are often the same thing. Consider concepts such as social networking (MUDS to *Second Life*), or hot YouTube videos that are already old and old email messages forever circulated and rediscovered as new. This constant repetition, tied to an inhumanly precise and unrelenting clock, points to a factor more important than speed—a nonsimultaneousness of the new, which I argue sustains new media as such.

Also key to the newness of the digital is a conflation of memory and storage that both underlies and undermines digital media's archival promise. Memory, with its constant degeneration, does not equal storage; although artificial memory has historically combined the transitory with the permanent, the passing with the stable, digital media complicates this relationship by making the permanent into an enduring ephemeral, creating unforeseen degenerative links between humans and machines. As I explain in more detail later, this conflation of memory with storage is not due to

some inherent technological feature, but rather due to how everyday usage and parlance arrests memory and its degenerative possibilities in order to support dreams of superhuman digital programmability. Unpacking the theoretical implications of constantly disseminated and regenerated digital content, this paper argues these dreams create, rather than solve, archival nightmares. They proliferate nonsimultaneous enduring ephemerals.

The Future, This Time Around

Prophesying the future of digital media is, once more, in fashion. With the now-embarrassing utopian and dystopian hype around the internet and Y2K comfortably behind us (or at least archived), there is a growing impatience with the so-called critical hindsight that flourished after the dotbombs and 9/11. Rather than the sobering if banal reassessments of internet communications as a “double-edged sword,” the main strain of digital media analysis—popular and scholarly—is on future possibilities.¹ Howard Rheingold, who helped popularize virtual reality and virtual communities, has written a book on the next social revolution, smart mobs; everyone is now speculating about the web 3.0, the semantic web in which

1. After 9/11, the discourse of the internet as inherently good came under attack. Steven Levy, among other authors, who fought against the Communications Decency Act, suddenly “discovered” the dark side of the internet, writing, “modern technologies that add efficiency, power and wonder to our lives inevitably deliver the same benefits to evildoers. The Internet is no exception” (Steven Levy, “Tech’s Double-Edged Sword,” *Newsweek* [Nexis], 24 Sept. 2001). After the dotcom boom, criticality was also the buzz word in more academic circles. For instance, the Inter-Society for Electronic Arts 2004 symposium, one of the largest and longest-running international digital art symposiums, emphasized themes such as critical interactivity and had a reflective focus. In contrast, the 2006 symposium emphasized themes such as “transvergence,” arguing: “new ideas and possibilities never before considered become evident when diverse disciplines intersect” (Steve Dietz, “ZeroOne San Jose / ISEA2006 Themes,” 01sj.org/content/view/188/30/). Hyperpolis 3.0, a small annual new-media conference, also emphasized “really useful media” for its 2006 conference, arguing that we already know too much about “media communications technologies as instruments of social control. . . . about media discourses as, on the one hand, ‘popular culture’: alienated and commodified cultural forms; and on the other, ‘cultural theory’: paranoid cosmologies of hyper-rhetoric, and the ubiquitous inevitability of evil” (idmi.poly.edu/?q=drupal/&q=hyper). Importantly, the criticality discovered after 9/11 also rewrote history, erasing the critical strains in digital media that always existed.

information and meaning will finally coincide.² Even longstanding critical organizations, such as the Australian organization fibreculture, dedicated to “critical and speculative interventions in the debate and discussions concerning information technology,” have joined the bandwagon, entitling the 2007 Digital Arts and Culture (DAC) association’s conference in Perth “The Future of Digital Media.”³

This future 2.0, like web 2.0 or 3.0, is not as utopian or bold as its mid-1990s predecessor, which was billed as *the* future. There are no upbeat yet paranoid commercials promising an end to racial discrimination and the beginnings of a happy global village; there are no must-read cyberpunk novels or films outlining its gritty, all-encompassing nature, although new media does now encompass bio- and nanotech.⁴ This return to the future as future simple—as what will be, as what you will do, as a programmed upgrade to your already existing platform—will no doubt recede and then reappear. Its cycle is partly driven by economics. Silicon Valley has recovered from the demise of the “new economy.” Google is trading well over four hundred dollars per share. Ipods and BlackBerry devices are everywhere. There is a sense that something is and has changed. NBC announced layoffs in 2006 not only because its programming is doing poorly but also because kids just aren’t watching TV on TV anymore.⁵ Also, Facebook has moved successfully from college campuses to the English-speaking public in general, and Michael Zuckerberg is apparently replacing Larry Page and Sergey Brin as the valley’s new IT kid. YouTube is impacting U.S. presidential elections; CNN now covers blog content as breaking news; and Skype seems poised to make the videophone, conceived in the 1970s and 1980s, an everyday reality.⁶

This return to the future or to the “emerging” in new media and its study is also a reaction to a perceived crisis within net criticism. When, in 2001, Lev Manovich chastised scholars for focusing on future rather than

2. See Howard Rheingold, *Smart Mobs: The Next Social Revolution* (Cambridge, Mass., 2003), and John Markoff, “Entrepreneurs See a Web Guided by Common Sense,” *New York Times*, 12 Nov. 2006, www.nytimes.com/2006/11/12/business/12web.html?ex=1320987600&en=254d697964cedc62&ei=5088

3. www.fibreculture.org/, and www.beap.org/dac/

4. For more on the mid- to late-1990s utopian vision of the internet, see Wendy Hui Kyong Chun, *Control and Freedom: Power and Paranoia in the Age of Fiber Optics* (Cambridge, Mass., 2006).

5. See David Lieberman, Peter Johnson, and Gary Levin, “NBC Universal Plans Cost Cuts, Layoffs,” *USA Today*, 20 Oct. 2006, www.usatoday.com/money/media/2006-10-19-nbc_x.htm

6. See Michael Arrington, “85% of College Students Use FaceBook,” *TechCrunch*, 7 Sept. 2005, www.techcrunch.com/2005/09/07/85-of-college-students-use-facebook/, and Ryan Lizza, “The YouTube Election,” *New York Times*, 20 Aug. 2006, www.nytimes.com/2006/08/20/weekinreview/20lizza.html?ex=1313726400&en=a605fabfcb81eebf&ei=5088&partner=rssnyt&emc=rss

already existing technologies—for conflating demo with reality, fiction with fact—and Peter Lunenfeld and Geert Lovink categorized much theoretical work as “vapor theory,” their criticism seemed a much-needed admonishment.⁷ It was a call for theorists to wake up from their virtual reality or, to play with William Gibson’s famous description of the matrix, their consensually hallucinated cyberspace. Even Gibson has started writing about actually existing technology.⁸ Engaging the present, however, has not been so easy. Gibson’s more recent books have not been as popular as his early ones. It would seem that presently existing media objects are rather boring or have a short lifespan. Indeed, in a way to avoid both the future and the present, Neal Stephenson now writes about the past, and the scholarly trend towards “media archaeology” is similarly retrospective, even if it is not traditionally historical or progressivist.

Speed and variability apparently confound critical analysis. According to Lovink, “because of the speed of events, there is a real danger that an online phenomenon will already have disappeared before a critical discourse reflecting on it has had the time to mature and establish itself as institutionally recognized knowledge.”⁹ More broadly, McKenzie Wark has argued that traditional scholarship is incompatible with the types of images and events, produced and disseminated along lightninglike speed media vectors, that interrupt the homogenous and abstract formal time of scholarship.¹⁰ In making this diagnosis, Wark draws from the work of Paul Virilio, who has argued that cyberspace has implemented a real time that is eradicating local spaces and times. This global one time threatens “a total loss of the bearings of the individual”¹¹ and “a loss of control over reason,” as the interval between image and subject disappears.¹² More narrowly, Manovich has argued that the critical blindness brought about by speed is peculiarly American: “the speed with which new technologies are assim-

7. See Lev Manovich, *The Language of New Media* (Cambridge, Mass., 2001), and Peter Lunenfeld, “Interview with Peter Lunenfeld,” interview by Geert Lovink, 31 July 2000, www.nettime.org/Lists-Archives/nettime-1-0008/msg00008.html

8. See William Gibson, *Pattern Recognition* (New York, 2003).

9. Lovink, *My First Recession: Critical Internet Culture in Transition* (Amsterdam, 2003), p. 12.

10. See McKenzie Wark, “The Weird Global Media Event and the Tactical Intellectual [Version 3.0],” in *New Media, Old Media: A History and Theory Reader*, ed. Chun and Thomas Keenan (New York, 2006), pp. 265–76.

11. Paul Virilio, “Speed and Information: Cyberspace Alarm!” *CTheory*, www.ctheory.net/articles.aspx?id=72

12. Virilio, “The Visual Crash,” in *Ctrl [Space]: Rhetorics of Surveillance from Bentham to Big Brother*, ed. Thomas Y. Levin, Ursula Frohne, and Peter Weibel (exhibition catalog, Center for Art and Media, 12 Oct. 2001–24 Feb. 2002), p. 112; see Virilio, “Red Alert in Cyberspace!” www.watsoninstitute.org/infopeace/vy2k/red-alert.cfm

lated in the United States makes them ‘invisible’ almost overnight: they become an assumed part of the everyday existence, something which does not seem to require much reflection. The slower speed of assimilation and the higher costs involved give other countries more time to reflect upon new technologies, as it was the case with new media and the Internet in the 1990s.¹³ Manovich’s geographic analysis and his linking of speed to cost is intriguing, but once again speed is labeled as the culprit. In addition to speed, malleability also makes criticism difficult by troubling a grounding presumption of humanities research: the reproducibility of sources. The fact that we cannot all access the same text—because, for example, the page has simply disappeared—seems an affront to scholarly analysis.¹⁴ This lack of verifiability gives a different spin to discourses of trust that dominate technology planning.

In response to these difficulties, Lovink and Wark both argue that the time of theory itself needs to change; Lovink’s “theory on the run” and Wark’s theory as “micro-event” take on the same temporality or speed as digital media, refusing to stand outside their mode of dissemination. Lovink’s theory is a “living entity, a set of proposals, preliminary propositions and applied knowledge collected in a time of intense social-technological acceleration.” It is not only on the run because it engages the present but also because it “expresses itself in a range of ways, as code, interface design, social networks and hyperlinked aphorisms, hidden in mailing-list messages, weblogs and chatrooms and sent as SMS messages.”¹⁵ Wark similarly discusses the work of tactical intellectuals as a kind of micro-event in which “the media tactician presents an image that endangers the conventions of journalistic narrative time, yet which is capable of inserting itself into it.”¹⁶ That is, the micro-event travels along the same media vectors as the mainstream event itself, displacing the event’s terms in its travels. Wark’s critical work exemplifies this kind of intervention; it appears first on the net and then later in print. Although I am sympathetic to these

13. Manovich, “New Media from Borges to HTML,” in *The New Media Reader*, ed. Noah Wardrip-Fruin and Nick Monfort (Cambridge, Mass., 2003), p. 13.

14. If the validity of the scientific method rests on (hypothetical) experimental reproducibility, the validity of a humanities-based critique depends on access to cited documents. The fact that criticism still happens reveals the extent to which both humanities and scientific scholarship itself depends on a “virtual witnessing.” For more on the importance of virtual witnessing to the scientific method, see Steven Shapiro and Simon Schaffer, *Leviathan and the Air-Pump: Hobbes, Boyle, and the Experimental Life* (Princeton, N.J., 1989), and Peter Dear, *Discipline and Experience: The Mathematical Way in the Scientific Revolution* (Chicago, 1995).

15. Lovink, *My First Recession*, pp. 15, 42.

16. Wark, “Robot Journalists and the Ironies of Tactical Media,” www.nettime.org/Lists-Archives/nettime-l-0205/msg00093.html

efforts and agree that digital media criticism needs to be on the net rather than simply about it, I also believe we need to think beyond speed.

The fact that the present is hard to engage or that scholarly certainty lags behind its object of analysis or that there is a need for intervention is hardly profound. Scholars studying global climate change, for instance, have consistently argued that by the time we know whether or not their predictions are true it will be too late. Thus, one must act as though future predictions (models or demos) were fact in order to prevent the predicted future from taking place. Also, the lag between a digital object's creation and its popular or scholarly uptake—its nonsimultaneous dissemination—does not belie new media, but rather, as I explain later, grounds it as new. Further, ephemerality is not new to new media. Television scholars have been grappling with this very question for years. Focusing on actually existing shows, rather than future episodes, they have theorized TV content in terms of flow, segmentation, and liveness.¹⁷ So, what is different or new about new media?

Most obviously, networked new media does not follow the same logic of seriality as television; flow and segmentation do not quite encompass digital media's ephemerality. Programming TV and programming new media are significantly different enterprises. To program a television show is to schedule or to broadcast it; to program a computer is to produce a series of stored instructions that supposedly guarantee—and often stand in for—a certain action. One is descriptive, the other prescriptive. Second (and not unrelated), digital media with its memory was supposed to be the opposite of or the solution to television. That is, new-media scholars' blindness to the similarities between new media and TV is ideological; it stems from an overriding belief in digital media as memory—and thus possibly memorable—and TV as liveness.¹⁸ When TV was still TV, memory supposedly marked the difference between it and digital media; unlike TV, digital media's content, like the programs it runs, was to be available 24/7. The always-thereness of digital media was to make things more stable, more lasting. Digital media, through the memory at its core, was supposed to solve, if not dissolve, archival problems such as degrading celluloid or

17. Most influentially, Raymond Williams has theorized television in terms of flow in his *Television: Technology and Cultural Form* (London, 1974), and Jane Feuer analyzed the ideology of liveness and the relationship between flow and segmentation in "The Concept of Live Television: Ontology as Ideology," in *Regarding Television: Critical Approaches—An Anthology*, ed. E. Ann Kaplan (Frederick, Md., 1983), pp. 12–22.

18. Manovich, in *The Language of New Media*, for instance, makes parallels between new media and film, virtually ignoring TV altogether. For TV and the ideology of liveness, see Feuer's "The Concept of Live Television." For more on the differences and similarities between TV and the internet, see Chun, "Why Cyberspace," *Control and Freedom*, pp. 37–76.

scratched vinyl, not create archival problems of its own. The limited lifespan of CDs will no doubt shock those who disposed of their vinyl in favor of digitally remastered classics, that is, if they still use CDs or an operating system that can read them. Old computer files face the same problem.

The major characteristic of digital media is memory. Its ontology is defined by memory, from content to purpose, from hardware to software, from CD-ROMs to memory sticks, from RAM to ROM. Memory underlies the emergence of the computer as we now know it; the move from calculator to computer depended on “regenerative memory.”¹⁹ John von Neumann in his mythic and controversial *First Draft of a Report on the EDVAC* (1945) deliberately used the term *memory organ* rather than *store*, also in use at the time, in order to parallel biological and computing components and to emphasize the ephemeral nature of vacuum tubes.²⁰ Vacuum tubes, unlike mechanical switches, can hold values precisely because their signals can degenerate—and thus regenerate. The internet’s content, memorable or not, is similarly based on memory. Many websites and digital media projects focus on preservation: from online museums to the YouTube phenomenon Geriatric1927, from Corbis to the Google databanks that store every search ever entered (and link each to an IP address, arguably making Google the Stasi resource of the twenty-first century). Memory allegedly makes digital media an ever-increasing archive in which no piece of data is lost.

This always-thereness of new media is also what links it to the future as future simple, as what will be, as predictable progress. By saving the past, it was supposed to make knowing the future easier. More damningly, it was to put into place the future simple through the threat of constant exposure; as a *New York Times* article questioned in response to the posting on YouTube of a clip of Senator George Allen making a racist remark: “If . . . any moment of a candidate’s life can be captured on film and posted on the Web, will the last shreds of authenticity be stripped from our public officials?”²¹ Intriguingly, this formulation assumes that racist slurs are the authentic and the true and that public exposure always makes behavior more banal. However, given the legion of students with compromising Facebook entries who seem oblivious to the fact that potential employers can

19. The move from calculator to computer is also the move from mere machine to human-emulator; the term computer was first resisted by IBM because computers were initially human. To call a machine a computer was to imply job redundancy; see Martin Campbell-Kelly and William Aspray, *Computer: A History of the Information Machine* (New York, 1996), p. 115.

20. See John von Neumann, *First Draft of a Report on the EDVAC*, in *The Origins of Digital Computers*, ed. Brian Randell (Berlin, 1973), p. 357.

21. Lizza, “The YouTube Election.”

check these entries and given that people increasingly record their own “transgressions” (such as the English happy slappers), it is not so clear that this assumption will hold, even for politicians. Allen, after all, made his comment at a public rally and directly addressed the Indian American man holding the video recorder. Regardless, digital media was supposed to—in its very functioning—encapsulate the enlightenment ideal that better information leads to better knowledge, which in turn guarantees better decisions.²² As a product of programming, it was to program the future.

As We May Think

This desire for programmability, sustained by a conflation of description with prescription, is most evident in the canonization of Vannevar Bush’s “As We May Think.”²³ The significance of this text is not understated; it is on almost all Introduction to Digital Media course syllabi and is considered to be as influential as, if not more than, Gibson’s *Neuromancer* because “pioneers” such as Douglas Engelbart and Ted Nelson have consistently listed it as an inspiration to them.²⁴ If *Neuromancer* has disappeared from syllabi as digital media criticism has moved away from the now embarrassingly fictional and utopian, the equally fictional and utopian “As We May Think” has survived because of this direct line of influence, which supposedly grounds it (particularly its validation of a massive branching structure) as a precursor to the WWW.²⁵ However, the fact that the memex—the machine prophesied by Bush but never built—is considered a precursor should make us pause because the memex is linked to a mechanical, analog future that has not and arguably *may not* come to pass.²⁶ By conflating the memex and the internet, the ephemerality of digital media is covered over and, more importantly, questions of forgetting and degradation are turned into problems for media to solve, as one medium becomes the “memory” of the next.

Bush, in “As We May Think,” writing at the end of World War II, argues

22. For more on this ideal and its incapacity to explain public behavior, see Keenan, “Publicity and Indifference (Sarajevo on Television),” *PMLA* 117 (Jan. 2002): 104–16.

23. See Vannevar Bush, “As We May Think,” *Atlantic Monthly* (July 1945): www.theatlantic.com/doc/194507/bush; hereafter abbreviated “A.”

24. See Douglas Engelbart, “Augmenting Human Intellect: A Conceptual Framework” (1962), www.bootstrap.org/augdocs/friedewald030402/augmentinghumanintellect/ahi62index.html, and Ted Nelson, *Literary Machines: The Report on, and of, Project Xanadu Concerning Word Processing, Electronic Publishing, Hypertext, Thinkertoys, Tomorrow’s Intellectual Revolution, and Certain Other Topics Including Knowledge, Education, and Freedom* (Sausalito, Calif., 1981).

25. See Manovich, “New Media from Borges to HTML.”

26. Indeed, Bush deliberately contrasts the memex to expensive digital computers in his “Memex Revisited,” in *New Media, Old Media*, pp. 85–95.

that the crucial problem facing scientists and scientific progress is access. He writes, “a record if it is to be useful to science, must be continuously extended, it must be stored, and above all it must be consulted.” However, “publication has been extended far beyond our present ability to make real use of the record. The summation of human experience is being expanded at a prodigious rate, and the means we use for threading through the consequent maze to the momentarily important item is the same as was used in the days of square-rigged ships” (“A”). To adequately access the scientific record, he proposes a mechanical solution, the memex (figs. 1–2). The memex is a desklike machine with two projectors that would enable its user to make permanent associative links between documents and to retrieve them at will. The documents were to be stored as microfilm and dropped into the machine as necessary. Documents could also be added; depressing a lever would cause contents placed at the top of the memex to be photographed into the next blank space in memex film. Although the compression offered by microfilm was important, associative indexing distinguished the memex, for Bush argued that the prime issue was selection; the human record was not being consulted because of cumbersome systems of indexing. Unlike these alphabetical systems, the memex was to create associative trails:

When the user is building a trail, he names it, inserts the name in his code book, and taps it out on his keyboard. Before him are the two items to be joined, projected onto adjacent viewing positions. At the bottom of each there are a number of blank code spaces, and a pointer is set to indicate one of these on each item. The user taps a single key, and the items are permanently joined. In each code space appears the code word. Out of view, but also in the code space, is inserted a set of dots for photocell viewing; and on each item these dots by their positions designate the index number of the other item.

Thereafter, at any time, when one of these items is in view, the other can be instantly recalled merely by tapping a button below the corresponding code space. Moreover, when numerous items have been thus joined together to form a trail, they can be reviewed in turn, rapidly or slowly, by deflecting a lever like that used for turning the pages of a book. It is exactly as though the physical items had been gathered together from widely separated sources and bound together to form a new book. It is more than this, for any item can be joined into numerous trails. [“A”]

The memex was, through unseen connections in code space, to simulate the creation of new physical media. This code space did not function as the space of digital programming in which material is generated, but rather as

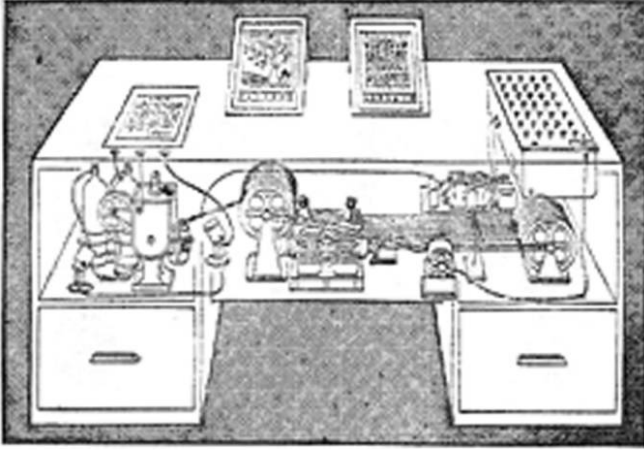

FIGURE 1. The memex.

an invisible space of place markers. This associative linking was to make the memex closer to the human mind, the inspiration for the memex. Describing the human mind, Bush wrote, “with one item in its grasp, it snaps instantly to the next that is suggested by the association of thoughts, in accordance with some intricate web of trails carried by the cells of the brain. It has other characteristics, of course; trails that are not frequently followed are prone to fade, items are not fully permanent, memory is transitory” (“A”). In contrast, the memex’s traces were not to fade, making it even better than its predecessor.

Bush did not undersell the importance of the memex. He argued that man needs

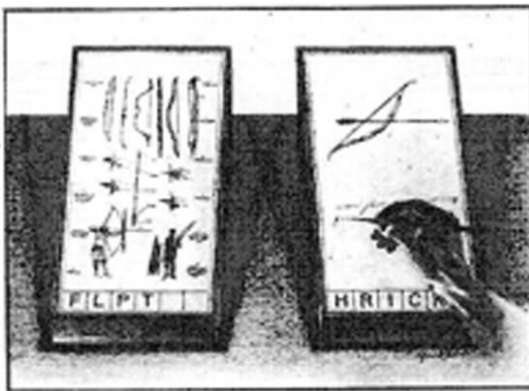

FIGURE 2. The memex.

to mechanize his records more fully if he is to push his experiment [human civilization] to its logical conclusion and not merely become bogged down part way there by overtaxing his limited memory. His excursions may be more enjoyable if he can reacquire the privilege of forgetting the manifold things he does not need to have immediately at hand, with some assurance that he can find them again if they prove important. ["A"]

Not only would we be granted once more the privilege of forgetting (as though any of us could ever be exempt from such a privation), but we would be saved from repetition—repetitive thought and repetitions in thought. According to Bush, man should not be burdened with repetitive thought processes like arithmetic, for which there are powerful mechanical aids. The creative aspect of thought, Bush writes, “is concerned only with the selection of the data and the process to be employed and the manipulation thereafter is repetitive in nature and hence a fit matter to be relegated to the machine” (“A”). The memex could also prevent repetitive discoveries, for the danger of nonmechanically induced forgetting is repetition. In “Memex Revisited,” which is itself an interesting repetition of “As We May Think,” he contends:

An Austrian monk, Gregor Mendel, published a paper in 1865 which stated the essential bases of the modern theory of heredity. Thirty years later the paper was read by men who could understand and extend it. But for thirty years Mendel’s work was lost because of the crudity with which information is transmitted between men.

This situation is not improving. The summation of human experience is being expanded at a prodigious rate, and the means we use for threading through the consequent maze to the momentarily important items are almost the same as in the days of square-rigged ships. We are being buried in our own product. Tons of printed material are dumped out every week. In this are thoughts, certainly not often as great as Mendel’s, but important to our progress. Many of them become lost; many others are repeated over and over and over.²⁷

Thus the scientific archive, rather than pointing us to the future, is trapping us in the past, making us repeat the present over and over again. Our product is burying us and the dream of linear additive progress is limiting what we may think; but the phrase “as we may think” is richly ambiguous. At one level, it refers to a technologically enhanced future: what we might

27. Bush, “Memex Revisited,” p. 85. See “A,” quoted above on p. 156.

think if we develop prosthetic machines to supplement and access the human record or what we might think without these devices. The word *may*, however, also refers to an authoritarian sanction; one is given the right to think *X*, one may think *X*, in which case the authority would be the machines themselves, our supposedly loyal servants. Most importantly for this argument, *may* is an uncertain link to the future; one may think this, but one is not sure. Reading against the grain of Bush's argument, I contend that this uncertainty stems not from the lack of devices such as the memex but from the act of reading itself.

In Bush's writing, and in prognoses for the information revolution more generally, there is no difference between access to and understanding the record, between what would be called, perhaps symptomatically, machine reading and human reading and comprehension, between information and argument. The difficulty supposedly lies in selecting the data, not in reading it, for it is assumed that reading is a trivial act, a simple comprehension of the record's content. Once the proper record is selected, there is no misreading, no misunderstanding, only transparent information. If the scientific record has not been advanced, if thought is repeated, it is because something has not been adequately disseminated. Bush's argument assumes that human records make possible the construction of an overarching archive of human knowledge in which there is no gap, no absence—a summation of human knowledge. The scientific archive thus restores or should restore to man everything that has eluded him.²⁸ So if there is discontinuity in history it is due to a historical accident, to our inability to adequately consult the human record, to human fallibility. This accident, however, can be solved by machines, which are viewed here as surprisingly accident-free and permanent.

A machine alone, however, cannot turn “an *information explosion* into a *knowledge explosion*”;²⁹ it cannot fulfill the promise of what Foucault has called traditional history. Even media as stable as microfilm fade and break, and this forgetting of the physics of the storage medium—this conversion of medium into storage—grounds Bush's progressivist and idealist ideology. Also, as the case of Mendel reveals, the problem is not access but rather larger epistemological frameworks. All three researchers who performed similar experiments to Mendel's thirty-five years after him consulted the scientific record and “found” Mendel, which means that Mendel's paper was not lost. The question is not, Why was Mendel forgotten?

28. This is Foucault's description of traditional history in his *The Archaeology of Knowledge*, trans. A. M. Sheridan Smith (New York, 1982).

29. Wardrip-Fruin and Montfort, introduction to “As We May Think,” in *The New Media Reader*, p. 35.

but, rather, why, in 1900, was he remembered (and exactly what was remembered) three times independently? And why, in the history of science, is Mendel constantly being rediscovered? As Jann Sapp argues in “The Nine Lives of Gregor Mendel,” this constant reinvocation is linked to the desire, on the part of reformers, to pin Mendel down as the source of *their* genetics.³⁰ Repetition is thus not the evidence of thought wasted but of thought disseminated. Repetition, as Derrida has argued, both makes possible and impossible the archival process; it is the fever, the destruction, at the heart of the archive.³¹ The pleasure of forgetfulness is to some extent the pleasure of death and destruction. It is thus no accident that this supplementing of human memory has also been imagined as the death of the human species in so many fictions and films and déjà vu as the mark of the artificial in *The Matrix*.

The example of Mendel is also revealing because this belief in sources—Mendel as the source of genetics, memex as the source of the internet, and, as I have argued elsewhere, code as the source of our computers—is ultimately based on a conflation of storage with access, of memory with storage, of word with action.³² This belief depends on our machines as more stable and permanent and, thus, better record holders than human memory; it depends on an analogy between digital and analog media. This belief is remarkably at odds with the material transience of discrete information and the internet.

Digital media is not always there. We suffer daily frustrations with digital sources that just disappear. Digital media is degenerative, forgetful, erasable. This degeneration makes it both possible and impossible for it to imitate analog media. It is perhaps a history-making device, but only through its ahistorical (or memoryless) functioning, through the ways in which it constantly transmits and regenerates text and images. If, as Mary Ann Doane has argued, film as a historical artifact and the filmic moment as historical event are inextricably intertwined, the two are separated in digital media, and it is this separation that grounds computer memory as such.³³ The age of a computer memory device rarely corresponds with the age of the memory it holds; the device and its content do not fade together. If computer memory is like anything, it is like erasable writing; but, if a

30. See Jann Sapp, “The Nine Lives of Gregor Mendel,” in *Experimental Inquiries: Historical, Philosophical, and Social Studies of Experimentation in Science*, ed. H. E. Le Grand (Dordrecht, 1990), pp. 137–66.

31. See Jacques Derrida, *Archive Fever: A Freudian Impression*, trans. Eric Prenowitz (Chicago, 1996).

32. See Chun, “Code as Media” (unpublished paper).

33. See Mary Ann Doane, *The Emergence of Cinematic Time: Modernity, Contingency, the Archive* (Cambridge, Mass., 2002), p. 223.

penciled word can be erased because graphite is soft, a computer's memory can be rewritten because its surface constantly fades.

Moving Memory

Von Neumann's *First Draft of a Report on the EDVAC* introduced the concept of stored-program computing and memory to the U.S. military and the academy. Intriguingly, it also began the freezing of memory and execution, key to the emergence of computers as media machines.

A hallmark of this report is its abstractness; rather than describing actually existing vacuum tubes and mercury delay lines, von Neumann used ideal "elements drawn not from telecommunications engineering but rather from Warren McCulloch and Walter Pitts's idealized, cyberneticized neurons (which were themselves inspired by the work of Alan Turing). These idealized neurons, like software after them, were based on a conflation of stimulus with action, word with result. McCulloch and Pitts sought to create "a logical calculus of the ideas immanent in nervous activity" through a conflation of word with result, asserting that "the response of any neuron [is] factually equivalent to a proposition which proposed its adequate stimulus."³⁴ That is, an instruction or program is functionally equivalent to its result. As I have argued elsewhere, this conflation grounds programming, in which process in time is reduced to process in space. As Edsger Dijkstra asserts in his famous "Go to Statement Considered Harmful," "the quality of programmers is a decreasing function of the density of go to statements in the programs they produce" because they go against the fundamental tenet of what Dijkstra considered to be good programming, namely, the necessity to "shorten the conceptual gap between the static program and the dynamic process, to make the correspondence between the program (spread out in text space) and the process (spread out in time) as trivial as possible."³⁵ That is, go tos make difficult the conflation of instruction with its product—the reduction of process to command, execution to legislation—which grounds the emergence of software as a concrete entity and commodity, which grounds programs as the source of a computer's actions. Go tos make it difficult for the source program to act as a legible source, painfully revealing the work necessary to make the source code a viable source and the fact that source

34. Warren McCulloch and Walter Pitts, "A Logical Calculus of the Ideas Immanent in Nervous Activity," in McCulloch, *Embodiments of Mind* (Cambridge, Mass., 1965), p. 21.

35. Edsger W. Dijkstra, "Go to Statement Considered Harmful," in *Software Pioneers: Contributions to Software Engineering*, ed. Manfred Broy and Ernst Denert (Berlin, 2002), p. 352.

code is only source code after the fact.³⁶ This glossing over the vicissitudes of execution is also evident in von Neumann's discussion of memory.

Memory, which von Neumann initially viewed as afferent neurons, was also not a simple borrowing from biology. By calling certain parts of the computer a "memory organ," von Neumann was asserting, against biological evidence, that such an organ existed. This memory, unlike Bush's imaginings, was digital in form. Von Neumann's analogy between computer and human memory depends on a leap of faith. It is an analogy to something, which, he admitted over ten years after the draft, is unknown but logically necessary. In *The Computer and the Brain*, von Neumann writes:

It is just as well to admit right at the start that all physical assertions about the nature, embodiment, and location of [human memory] are equally hypothetical. We do not know where in the physically viewed nervous system a memory resides; we do not know whether it is a separate organ or a collection of specific parts of other already known organs, etc. It may well be residing in a system of specific nerves, which would then have to be a rather large system. It may well have something to do with the genetic mechanism of the body. We are as ignorant of its nature and position as were the Greeks, who suspected the location of the mind in the diaphragm. The only thing we know is that it must be a rather large-capacity memory, and that it is hard to see how a complicated automaton like the human nervous system could do without one.³⁷

This statement, which seems so carefully qualified—we basically do not know what the memory is or where it resides—at the same time asserts the existence of a memory organ—or set of organs. This assertion assumes the separation of action from data, of order from machinic execution that was

36. The argument that source code is only source code after the fact draws from my work in "Code as Media." In it, I stress the fact that source code is historically posterior to object code—source code emerged with the introduction of higher-level programming languages and early programmers debugged the "object" rather than the source code. Source code is not executable. For it to become so, it must be compiled or interpreted, and this making-executable of code is not a trivial action; the compilation of code is not the same as translating a decimal number into a binary one. Rather, it involves instruction explosion and the translation of symbolic into real addresses, that is, a breakdown, using numerical methods, of the steps needed to perform what seems a simple arithmetic calculation. This is most clear in the use of numerical methods to turn integration—a function performed fluidly in analog computers—into a series of simpler arithmetical steps. Also, some programs may be executable, but not all compiled code within that program is executed; rather, lines are read in as necessary. So, source code thus only becomes source after the fact.

37. Von Neumann, *The Computer and the Brain* (1958; New Haven, Conn., 2000), p. 61.

put in place by computers. That is, although stored-program computing stores instructions and data within the same memory registers, it also strictly separates process and data. This guess as to capacity assumes that the brain stores information as bits, which are then processed by it, and not as traces of events through the combination of neurons, which is a field-based or analogy-based system of memory. Von Neumann's nervous system is a digital calculator, not an analog simulator.³⁸

Von Neumann's concept of memory also blurs the boundary between machine and human. The machine memory was to contain values and orders that were usually stored in an outside recording medium, such as paper cards, but not all values were to be placed inside the machine at all times. The machine was to have a hierarchy of memories based on access time. The primary memory comprised expensive registers to be accessed quickly and, ideally, randomly. The Institute for Advanced Study machine used a Williams tube (basically a television tube) as its primary memory. This memory was supplemented by a secondary memory or storage medium that could hold in blocks values needed for a calculation. Interestingly, the devices listed as possible secondary memories were also other forms of media: teletype tapes, magnetic wire or tapes, or movie film.³⁹ A third form of memory was "dead storage": the input or the output or, as von Neumann later put it in *The Computer and the Brain*, "the outside world."⁴⁰ This reference to the world outside of the computer as memory conflates storage with medium, the dead with the live, the dead with the de/regenerative. It makes computer memory a form of filing, where the paper file—the natural automata's alleged secondary memory—is "un-generative" and therefore deadly permanent.⁴¹ Again, before the use of

38. For more on the brain as an analog simulator, see Alain Berthoz, *The Brain's Sense of Movement*, trans. Giselle Weiss (Cambridge, Mass., 2000).

39. See Arthur W. Burks, Herman H. Goldstine, and von Neumann, *Preliminary Discussion of the Logical Design of an Electronic Computing Instrument* (Princeton, N.J., 1947), p. 6.

40. Von Neumann, *The Computer and the Brain*, p. 36.

41. This notion of memory as static files is linked to von Neumann's suspicion, perhaps drawn from psychoanalysis, that memories never die. McCulloch's paper "Why the Mind Is in the Head" followed von Neumann's "General and Logical Theory of Automata" at the same Hixon symposium; in it, McCulloch writes:

I see an argument that one might make against the view that memory in any form actually resides in the neurons. It is a negative argument, and far from cogent. How reasonable is it? This is the argument: There is a good deal of evidence that memory is static, unerasable, resulting from an irreversible change. (This is of course the very opposite of a "reverberating," dynamic, erasable memory.) Isn't there some physical evidence for this? If this is correct, then no memory, once acquired, can be truly forgotten. Once a memory-storage place is occupied, it is occupied forever, the memory capacity that it represents is lost; it will never be possible to store anything else there. What appears as forgetting is then not true forgetting, but merely the removal of that particular memory-storage region from a condi-

Wendy Hui Kyong Chun / *The Digital Ephemeral*

regeneration, the term in use was *store* (Charles Babbage's term), not memory. The predecessor to the EDVAC, the ENIAC, stored values in its function table, and, although these were later used to store instructions, these function tables were not called memory. The term *memory* or, initially, *regenerative memory* enters with mercury delay lines and Williams tubes—nonstatic devices that can hold values because their signals degenerate. Quickly, however—indeed in the same document—the difference between dynamic and static devices is erased; as the modifier *regenerative* is dropped, all storage becomes memory.

Storage cum memory also links computers to genetics. Von Neumann included genes within his category of memory, erasing the difference between memory accessible to the human mind and memory accessible to the human body. Given the etymology of *mind* as the state of being remembered, this is an intriguing erasure. By making genes a form of memory, von Neumann also erases the difference between individual and transgenerational memory, making plausible Lamarckian transmission; if chromosomes are a form of secondary memory, they can presumably be written by the primary. This genetic linkage to memory makes clear the stakes of conflating memory with storage—a link from the past to the future. Indeed, stored instructions as genes (or an approximation of them) was key to von Neumann's theory of self-reproducing automata.⁴²

Crucially, memory is an active process, not static. A memory must be held in order to keep it from moving or fading. Memory does not equal storage. While memory looks backward, according to the *OED*, to store is to furnish, to build stock. Storage or stocks always look towards the future. In computerspeak, one reverses common language because one stores something in memory. This odd reversal and the conflation of memory and storage glosses over the impermanence and volatility of computer memory. Without this volatility, however, there would be no memory. Memory stems from the same Sanskrit root for *martyr*, perhaps compara-

tion of rapid and easy availability to one of lower availability. It is not like the destruction of a system of files, but rather like the removal of a filing cabinet into the cellar. Indeed, this process in many cases seems to be reversible. Various situations may bring the "filing cabinet" up from the "cellar" and make it rapidly and easily available again. [McCulloch, *Embodiments of Mind*, pp. 92–93]

Von Neumann's move to files is intriguing, especially given the importance of files—and of disposing files—to modern bureaucracy and state power. For more on this, see Cornelia Vismann, *Files: Law and Media Technology*, trans. Geoffrey Winthrop-Young (Stanford, Calif., 2008).

42. See von Neumann, "The General and Logical Theory of Automata," *Papers of John von Neumann on Computing and Computer Theory*, ed. William Aspray and Arthur Burks (Cambridge, Mass., 1987), p. 421.

ble to the ancient Greek term for “baneful,” “fastidious.” Memory is an act of commemoration—a process of recollecting or remembering.

The commemoration, of course, entails both the permanent and the ephemeral. Memory, especially artificial memory, has traditionally brought together the permanent with the ephemeral, for instance, the wax tablet with erasable letters—the inspiration for classical mnemotechnics. As Frances A. Yates explains, the rhetorician treated architecture as a writing substrate, on which images, correlating to objects to be remembered, were inscribed. Summarizing the *Ad herennium*, she states:

The artificial memory is established from places and images, . . . the stock definition to be forever repeated down the ages. A *locus* is a place easily grasped by the memory, such as a house, an inter-columnar space, a corner, an arch, or the like. Images are forms, marks or simulacra . . . of what we wish to remember. For instance if we wish to recall the genus of a horse, of a lion, of an eagle, we must place their images on definite *loci*.

The art of memory is like an inner writing. Those who know the letters of the alphabet can write down what is dictated to them and read out what they have written. Likewise those who have learned mnemonics can set in places what they have heard and deliver it from memory. “For the places are very much like wax tablets or papyrus, the images like the letters, the arrangement and disposition of the images like the script, and the delivery is like the reading.”⁴³

Visiting these memorized places, one revives the fact to be recalled. This discussion of memory offers a different interpretation of the parallels between human and computer memory. The rhetorician was to recall a physical space within his mind; the image is not simply what is projected upon a physical space but also the space for projection. Similarly, computer memory (which too is organized spatially) is a storage medium *like* paper, but not quite. Both degenerate, revealing the limitations of the simile.

Memory as active process is seen quite concretely in early forms of regenerative memory, from the mercury delay line to the Williams tube. The serial mercury delay line took a series of electrical pulses and used a crystal to transform them into sound waves, which would make their way relatively slowly down the mercury tube (fig. 3). At the far end, the sound waves would be amplified and reshaped.⁴⁴ One tube could usually store

43. Frances Yates, *The Art of Memory* (Chicago, 1966), pp. 6–7.

44. See Michael R. Williams, *A History of Computing Technology* (Englewood Cliffs, N.J., 1977), pp. 306–16.

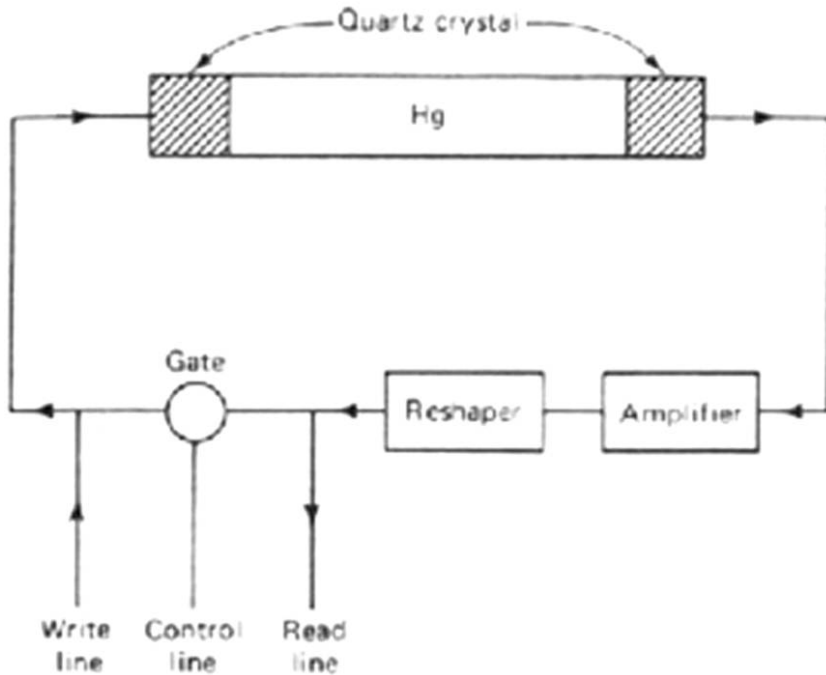

FIGURE 3. The mercury delay tube.

about one thousand binary bits at any given moment. Another early memory device, the Williams tube (fig. 4), derived from developments in cathode ray tubes (CRTs); the television set is not just a computer screen, but was also once its memory. The Williams tube, when a beam of electrons hits its phosphor surface, not only produces a spot of light but also a charge. This charge will persist for about .2 seconds before it leaks away and can be detected by a parallel collector plate. Thus, if this charged spot can be regenerated at least five times per second, memory can be produced in the same manner as the mercury delay tube. Current forms of memory also require regeneration. Today's RAM is mostly volatile and based on flip-flops, transistors, and capacitors, which require a steady electrical current. Although we do have forms of nonvolatile memory, such as flash memory, made possible by better insulated capacitors, they do have a limited read-write cycle.

Thus, as Wolfgang Ernst has argued, digital media is truly a *time-based medium*, which, given a screen's refresh cycle and the dynamic flow of information in cyberspace, turns images, sounds, and text into discrete

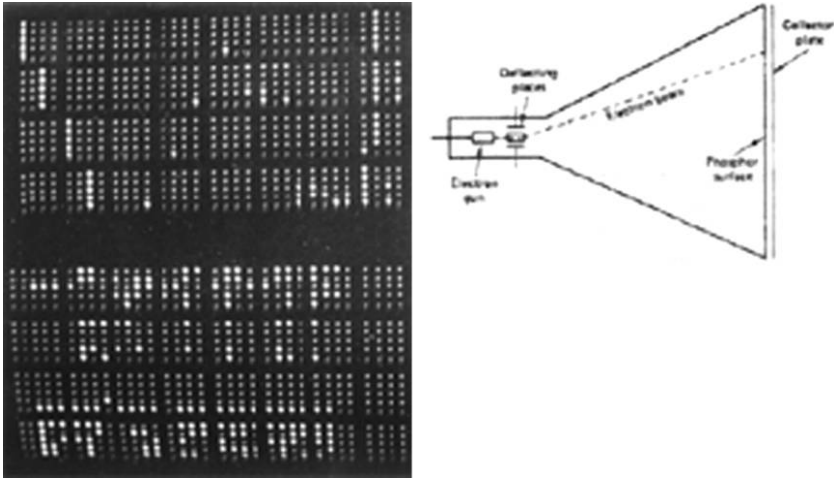

FIGURE 4. Williams tube.

moments in time. These images are frozen for human eyes only.⁴⁵ Information is dynamic, however, not only because it must move in space but also, and more importantly, because degeneration—not regeneration—makes memory possible, while simultaneously threatening it. Digital media, which is allegedly more permanent and durable than other media (film stock, paper, and so on), depends on a degeneration actively denied and repressed. This degeneration, which engineers would like to divide into useful and harmful (eraseability versus signal decomposition, information versus noise) belies the promise of digital computers as permanent memory machines. If our machines' memories are more permanent, if they enable a permanence that we seem to lack, it is because they are constantly refreshed so that their ephemerality endures, so that they may store the programs that seem to drive our machines.

This enduring ephemeral—a battle of diligence between the passing and the repetitive—also characterizes content. The internet may be available 24/7, but specific content may not. Further, if things constantly disappear, they also reappear, often to the chagrin of those trying to erase data. When Article III Groupie (A3G), the gossipy conservative and supposedly female author of *underneaththeirrobes.blogs.com*, came out as a thirty-year-old Newark-based U.S. Attorney named David Lat in an inter-

45. See Wolfgang Ernst, "Dis/continuities: Does the Archive Become Metaphorical in Multi-Media Space?" in *New Media, Old Media*, p. 118. Although this is certainly true for CRT screens, it is not necessarily true for LCD screens, which operate more like blinds that allow certain portions of light through or not.

view with *The New Yorker*, his site was temporarily taken down by the U.S. government.⁴⁶ Archives of his site—and every other site that does not reject robots—however, are available at the Internet Wayback Machine (web.archive.org) with a six-month delay.

Like search engines, the Internet Wayback Machine (IWM) comprises a slew of robots and servers that automatically and diligently, and in human terms obsessively, back up most webpages. Also like search engines, they collapse the difference between the internet, whose breadth is unknowable, with its backups; however, unlike search engines, the IWM does not use this data to render the internet into a library but rather uses these backups to create what it calls a “library of the Internet.” The library the IWM creates, though, is certainly odd, for it has no coherent shelving system; the IWM librarians do not offer a card catalog or a comprehensive content-based index.⁴⁷ This is because the IWM’s head librarian is a machine, only capable of accumulating differing texts. That is, its automatic power of discrimination only detects updates within a text. The IWM’s greatest oddity, however, stems from its recursive nature; it and its archives (the IWM diligently archives itself) are themselves included among the objects of its archive.

Logically, IWM is also recursive; the imperfect archives of the IWM are supposedly crucial to the ongoing relevance of libraries. The creators behind IWM state, “libraries exist to preserve society’s cultural artifacts and to provide access to them. If libraries are to continue to foster education and scholarship in this era of digital technology, it’s essential for them to extend those functions into the digital world.”⁴⁸ The need for cultural memory drives the IWM and libraries more generally. Noting the loss of early film archives due to the recycling of early film stock, the archivists state that they are building an “internet library” because

without cultural artifacts, civilization has no memory and no mechanism to learn from its successes and failures. And paradoxically, with the explosion of the Internet, we live in what Danny Hillis has referred to as our “digital dark age.”

The Internet Archive is working to prevent the Internet—a new

46. See Jeffrey Toobin, “SCOTUS Watch,” in “The Talk of the Town,” *The New Yorker*, 21 Nov. 2005, www.newyorker.com/talk/content/articles/051121ta_talk_toobin

47. This is because there are no shelves, no fixed relation between what is storable and the place they are stored. As Harriet Bradley has argued, the internet breaks the bond between location and storage; if before “only what has been stored can be located,” now “memory is no longer located in specific sites” (Harriet Bradley, “The Seductions of the Archive: Voices Lost and Found,” *History of the Human Sciences* 12, no. 2 [1999]: 113).

48. www.archive.org/about/about.php

medium with major historical significance—and other “born-digital” materials from disappearing into the past. Collaborating with institutions including the Library of Congress and the Smithsonian, we are working to preserve a record for generations to come.⁴⁹

The IWM is necessary because the internet, which is in so many ways *about* memory, has, as Ernst argues, no memory—at least not without the intervention of something like the IWM.⁵⁰ Other media do not have a memory, but they do age, and their degeneration is not linked to their regeneration. This crisis is brought about also because of the blind belief in digital media as memory. This belief in the internet as cultural memory, paradoxically, threatens to spread this lack of memory everywhere and plunge us negatively into a way way back machine: the so-called digital dark age. The IWM thus fixes the internet by offering us a “machine” that lets us control our movement between past and future by regenerating the internet on a grand scale. The IWM is appropriate in more ways than one; because webpages link to, rather than embed, images, which can be located anywhere, and because link locations always change, the IWM preserves only a skeleton of a page, filled with broken—rendered—links and images (fig. 5). These pages are not quite dead, but not quite alive either; the proper commemoration requires greater effort. These gaps or this skeleton visualizes not only the fact that our constant regenerations affect what is regenerated but also how these gaps—the irreversibility of this causal programmable logic—open the web as archive to a future that would not be a simple memory upgrade of the past.

Repetition and regeneration open the future by creating a nonsimultaneous new that confounds the chronological time they also enable. Consider, for instance, the temporality of weblogs. Blogs seem to follow the timing of newspapers in their plodding chronology, but blogs contain within themselves archives of their posts, making the blog, if anything, like the epistolary novel. Unlike the epistolary novel, which, however banal, was focused around a plot or a moral, the blog entries are tied together solely by the presence of the so-called author. What makes a blog uninteresting is not necessarily its content, which often reads like a laundry list of things done or to do, but rather its immobility. The ever-updating, inhumanly clocked time in which our machines and memories are embedded and constantly refreshed makes its material stale. The chronology, seemingly enabled by this time, is also compromised by these archives and the uncertainty of their regular reception. An older post can always be “discovered” as new; a new post is already old. This nonsimultaneousness of

49. Ibid.

50. See Ernst, “Dis/continuities,” p. 119.

Click **HERE** if you're using a 3.0 browser



wendy hui kyong chun
whkchun@princeton.edu

FIGURE 5. Internet Wayback Machine backup of <http://www.princeton.edu/~whkchun>.

the new, this layering of chronologies, means that the gap between illocutionary and perlocutionary in high-speed telecommunications may be dwindling, but—because everything is endlessly repeated—response is demanded over and over again. The new is sustained by this constant demand to respond to what we do not yet know; the goal of new media czars is to constantly create desire for what one has not yet experienced.

To put it most bluntly, this nonsimultaneity of the new—this enduring ephemeral—means we need to get beyond speed as the defining feature of digital media or global networked communications. Virilio's constant insistence on speed as distorting space-time and on real time as rendering us susceptible to the dictatorship of speed has generated much good work in

the field, but it can blind us to the ways in which images do not simply assault us at the speed of light.⁵¹ Just because images flash up all of a sudden does not mean that response or responsibility is impossible or that scholarly analysis is no longer relevant. As the new obsession with repetition reveals, an image does not flash up only once. The pressing questions are, Why and how is it that the ephemeral endures? And what does the constant repetition and regeneration of information effect? What loops and what instabilities does it introduce into the logic of programmability?

Digital media networks are not based on the regular obsolescence or disposability of information but rather on the resuscitability or the undead of information. Even text messaging, which seems to be about the synchronous or the now, enables the endless circulation of forwarded messages, which are both new and old. Reliability is linked to deletion; a database is considered to be unreliable (to contain “dirty data”) if it does not adequately get rid of older inaccurate information. Also, this repetition, rather than detracting from the message, often attests to its importance. Repetition becomes a way to measure scale in an almost inconceivably vast communications network.

Rather than getting caught up in speed, then, we must analyze, as we try to grasp a present that is always degenerating, the ways in which ephemerality is made to endure. What is surprising is not that digital media fades but rather that it stays at all and that we stay transfixed by our screens as its ephemerality endures.

51. See Virilio, “The Visual Crash” and “Speed and Information: Cyberspace Alarm!”