

# **Strategic Analysis of an Electricity Deficit in British Columbia**

**by**

**Adam Brooks**

B.A.Sc., University of British Columbia, 2003

Project Submitted in Partial Fulfillment of the  
Requirements for the Degree of  
Master of Business Administration

in the Executive MBA  
of the  
Faculty of Business Administration

**© Adam Brooks 2015**

**SIMON FRASER UNIVERSITY**

**Summer 2015**

All rights reserved.

However, in accordance with the *Copyright Act of Canada*, this work may be reproduced, without authorization, under the conditions for "Fair Dealing." Therefore, limited reproduction of this work for the purposes of private study, research, criticism, review and news reporting is likely to be in accordance with the law, particularly if cited appropriately.

# Approval

**Name:** Adam Brooks

**Degree:** Master of Business Administration

**Title of Project:** Strategic Analysis of an Electricity Deficit in British Columbia

**Supervisory Committee:**

---

**Dr. Michael Parent, Professor**

Senior Supervisor

Professor of Management Information Systems and Marketing Faculty of Business Administration

---

**Dr. Leyland Pitt, Professor**

Second Reader

Professor, Marketing and Dennis F. Culver EMBA Alumni Chair of Business Faculty of Business Administration

**Date Approved:** June 18<sup>th</sup>, 2015

## Partial Copyright Licence



The author, whose copyright is declared on the title page of this work, has granted to Simon Fraser University the non-exclusive, royalty-free right to include a digital copy of this thesis, project or extended essay[s] and associated supplemental files ("Work") (title[s] below) in Summit, the Institutional Research Repository at SFU. SFU may also make copies of the Work for purposes of a scholarly or research nature; for users of the SFU Library; or in response to a request from another library, or educational institution, on SFU's own behalf or for one of its users. Distribution may be in any form.

The author has further agreed that SFU may keep more than one copy of the Work for purposes of back-up and security; and that SFU may, without changing the content, translate, if technically possible, the Work to any medium or format for the purpose of preserving the Work and facilitating the exercise of SFU's rights under this licence.

It is understood that copying, publication, or public performance of the Work for commercial purposes shall not be allowed without the author's written permission.

While granting the above uses to SFU, the author retains copyright ownership and moral rights in the Work, and may deal with the copyright in the Work in any way consistent with the terms of this licence, including the right to change the Work for subsequent purposes, including editing and publishing the Work in whole or in part, and licensing the content to other parties as the author may desire.

The author represents and warrants that he/she has the right to grant the rights contained in this licence and that the Work does not, to the best of the author's knowledge, infringe upon anyone's copyright. The author has obtained written copyright permission, where required, for the use of any third-party copyrighted material contained in the Work. The author represents and warrants that the Work is his/her own original work and that he/she has not previously assigned or relinquished the rights conferred in this licence.

Simon Fraser University Library  
Burnaby, British Columbia, Canada

revised Fall 2013

## **Abstract**

The British Columbia (BC) Government introduced the Clean Energy Act in 2010. With the new legislation, BC Hydro has been mandated to be electricity self-sufficient by 2016. BC Hydro may not have enough generation capacity to meet the regulatory requirement in time. This project explores three potential options for Teck's Zinc Smelter to provide made-in-BC generation capacity to BC Hydro. After evaluating the options, this author recommends for Teck to make an offer to swap BC Hydro's imports with Teck's made-in-BC generation.

*For my family – Janet, Simon, Oliver, and Esme*

## **Acknowledgements**

Thank you to my cohort and instructors for a rewarding experience.

# Table of Contents

Approval.....	ii
Partial Copyright Licence .....	iii
Abstract.....	iv
Dedication.....	v
Acknowledgements.....	vi
Table of Contents.....	vii
List of Tables.....	ix
List of Figures.....	x
List of Acronyms.....	xi
Glossary.....	xii
Executive Summary .....	xiv

<b>Chapter 1. Introduction .....</b>	<b>1</b>
--------------------------------------	----------

<b>Chapter 2. Industry Analysis.....</b>	<b>2</b>
--	----------

2.1. Industry Definition.....	2
2.2. Supply Chain .....	2
2.3. Peak Capacity .....	3
2.3.1. Dispatchable Generation .....	3
2.3.2. Curtailable Load .....	4
2.4. Industry Boundaries.....	5
2.4.1. Products .....	5
2.4.2. Geography.....	5
2.4.3. Participants.....	6
2.5. Industry Dynamics .....	7
2.5.1. Porter's Five Force Analysis .....	7
The Threat of Entry .....	8
The Power of Suppliers.....	8
The Power of Buyers.....	9
The Threat of Substitutes.....	9
Rivalry Among Existing Competitors.....	9
2.5.2. Factors Affecting Porter's Five Forces (Macro Analysis).....	10
Technology and Innovation.....	10
Government and Stakeholders .....	10
Complements .....	11
Cannibalization.....	11
2.5.3. Long Run Assessment.....	11
2.6. Gap Analysis .....	12
2.6.1. Integrated Resources Plan .....	12
2.6.2. Willingness to Pay .....	13
2.6.3. Industry Valuation.....	14
2.7. Summary of Opportunity in the Industry.....	14

<b>Chapter 3. Firm Analysis</b> .....	<b>16</b>
3.1. Financial Analysis.....	16
3.2. Value Chain Analysis.....	18
3.2.1. Trail's Electricity Supply.....	20
3.3. Resources and Capabilities Analysis.....	22
Very large industrial electrical load.....	22
Capability to ramp up/down a large portion of load quickly.....	23
Zinc and co-products available in the market.....	23
Own hydroelectric generation in BC.....	24
Own transmission links to BC and US utilities.....	24
Zinc Smelter operates at full capacity.....	25
Not a direct customer of a public utility.....	25
3.4. Summary of Strengths and Weaknesses of Firm in the Industry.....	26
3.5. Opportunity Statement.....	27
<b>Chapter 4. Opportunity Analysis</b> .....	<b>29</b>
4.1. Alternatives.....	29
4.1.1. Alternative 1: Offer Surplus Generation Up to 10 MW.....	29
4.1.2. Alternative 2: Offer Curtailable Load Up to 32 MW.....	30
Trail's Curtailment Price Model.....	30
Expected Value of Load Curtailment.....	32
4.1.3. Alternative 3: Offer Generation Swap Up To 225 MW.....	32
4.2. Evaluation.....	34
4.3. Recommendation.....	38
<b>Chapter 5. Implementation</b> .....	<b>40</b>
5.1. Internal Stakeholders.....	40
5.2. External Stakeholders.....	41
<b>Chapter 6. Conclusion</b> .....	<b>43</b>
<b>References</b> <b>44</b>	
Appendix A. Hydroelectric Turbines on Raw Water Outflows.....	47



## List of Tables

Table 2.1.	Participants in the Peak Capacity Industry in BC.....	6
Table 3.1.	Relative Ranking of Teck’s Trail Operations compared to Other Zinc Smelters .....	17
Table 3.2.	Summary of Trail Operations’ Strengths and Weaknesses for Providing Peak Capacity to Public Utilities .....	26
Table 4.1.	Evaluation of Alternatives.....	37

## List of Figures

Figure 2.1.	Projected Generation Supply versus Internal Demand for Western Interconnection .....	5
Figure 2.2.	Porter’s Five Forces Model of the Peak Capacity Industry .....	7
Figure 2.3.	Projected Generation Supply versus Internal Demand for British Columbia.....	12
Figure 3.1.	Major Steps for Refining Zinc at Trail Operations .....	19
Figure 3.2.	Activity Map for Supplying Electricity to Trail Operations .....	20
Figure 4.1.	Typical Power Flow on Teck’s Power System .....	33
Figure 4.2.	Power Flow on Teck’s System during Swap.....	33

## List of Acronyms

BC	British Columbia
BC Hydro	BC Hydro and Power Authority
CEA	Clean Energy Act
CPA	Canal Plant Agreement
DSM	Demand Side Measure
GHG	Greenhouse Gas
IRP	Integrated Resources Plan
kW	Kilowatt
kWh	Kilowatt-hour
M	Must
MW	Megawatt
MWh	Megawatt-hour
S	Score
SCCT	Simple Cycle Combustion Turbine
Teck	Teck Metals Ltd. (A subsidiary of Teck Resources Ltd.)
US	United States
VRIL	Value Rarity Imitability Leverage
W	Weight
WS	Weighted Score

## Glossary

Curtaillable Load	A consumer's load that can be shut off upon request by the utility, typically under contract agreement. Usually the load must be shut off within 10 minutes of receiving a request.
Demand Side Measures	Methods for limiting electricity consumption, typically through energy conservation programs like codes, rebates, tariffs, and education.
Dispatchable Generation	Electrical generators that can be ramped up or down very quickly by an operator at any time. The most significant sources within BC are hydroelectric generating stations that have a reservoir.
Distribution	Lines and equipment that carry electricity over shorter distances at lower voltages from the substation to the consumer's load.
Energy	The quantity of power consumed or generated over time. Energy is described in kilowatt-hours (kWh) or Megawatt-hours (MWh).
Generation	Electrical generators are the source of the electrical supply. The hydroelectric generator is the most common source for generation in BC and consists of a water wheel coupled to a rotating electrical transformer, which converts mechanical energy to electric energy.
Intermittent Renewables	Electrical generators whose dispatch is determined by outside factors that are not under an operator's direct control. Examples include run-of-river, wind, and solar.
Load	The equipment that converts electricity into something useful for the consumer, for instance, heat, light, or mechanical energy.
Peak Capacity	The maximum instantaneous power that can be generated or delivered by the electricity grid including the generation, transmission, and distribution system. Peak Capacity is described in kilowatts (kW) or Megawatts (MW).
Peak Demand	The maximum instantaneous power drawn by the electricity grid. Daily, the time for Peak Demand is between 4 pm and 8 pm. Seasonally, it occurs during the hottest or coldest times of the year. Peak Demand is described in kilowatts (kW) or Megawatts (MW).
Transmission	Lines and equipment that carry electricity over longer distances at higher voltages from generators to distribution substations.

Western  
Interconnection

The group of electric utilities in western North America that are electrically connected during normal conditions. The geographic area covers from BC to Mexico and from the Pacific Ocean to the Great Plains.

Zinc Smelter

An industrial operation that produces refined zinc metal and possibly co-products from mined concentrates using hydro and pyro metallurgical processes.

## Executive Summary

With the introduction of the Clean Energy Act, BC Hydro has been mandated to be electricity self-sufficient by 2016. BC Hydro can no longer rely on imports to cover electricity shortfalls. According to their most recent resource plan, BC Hydro may not have enough capacity to meet the regulatory requirement in time.

Teck's Zinc Smelter located in Trail, BC uses a lot of electricity, enough to supply a small city. It is the second largest single electrical load in BC and has the ability to quickly ramp up or down a large portion of its electrical load. Teck also owns a hydroelectric generating station and transmission system for supplying its Zinc Smelter. While Teck's Zinc Smelter is not a direct customer of BC Hydro, it may be in a position to provide additional electricity capacity to BC Hydro.

The genesis for this strategic analysis was to consider the opportunity for Teck's Zinc Smelter to curtail production for the purpose of freeing up capacity for BC Hydro to use. After further review, it became evident that Teck could offer two more alternatives that were more dependable and convenient than curtailing load yet still cheaper than constructing new generation. The two other alternatives were (1) to offer Teck's surplus generation capacity or (2) to swap BC Hydro's imports with Teck's made-in-BC generation.

All three alternatives were evaluated based on criteria for regulatory, environmental, profitability, and quality. This author concluded that swapping generation would be the best fit for Teck, even though it would increase reportable Greenhouse Gas emissions for the Zinc Smelter. It is anticipated that the emissions could be offset by other social and environmental improvement projects, financed from going forward with the alternative. Swapping generation could increase profit by \$9 million per year for Teck's Zinc Smelter based on typical rates.

# Chapter 1.

## Introduction

The British Columbia (BC) Government introduced the Clean Energy Act in 2010. With the new legislation, the crown owned utility BC Hydro has been mandated to be electricity self-sufficient, meaning it can no longer rely on imports to cover electricity shortfalls. BC Hydro is moving forward with major capital projects like Site C to increase its generation capacity within the province; however, according to their most recent resource plan, BC Hydro may not have enough capacity to meet the regulatory requirement soon enough. Consequently, BC Hydro is currently looking for short term options including ways to reduce demand (BC Hydro, 2014).

Teck's Zinc Smelter located in Trail, BC uses a lot of electricity, enough to supply a small city. It is the second largest single electrical load in BC and has the ability to quickly ramp up or down a large portion of its electrical load. Teck also owns a hydroelectric generating station and transmission system for supplying its Zinc Smelter. While Teck's Zinc Smelter is not a direct customer of BC Hydro, it may be in a position to provide additional electricity capacity for BC Hydro to use.

The purpose of this strategic analysis is to explore whether there is a business opportunity for Teck's Zinc Smelter to provide made-in-BC electricity to BC Hydro.

Please note that the following analysis was written primarily to meet the requirements of the Teck-SFU Executive MBA Program. The opinions expressed in this analysis are the author's own and do not necessarily reflect the view of Teck, BC Hydro, or SFU.

## **Chapter 2.**

### **Industry Analysis**

#### **2.1. Industry Definition**

The electricity industry is well established and highly regulated in BC. In recent years, the industry has been under pressure to develop renewable generation and to promote energy conservation. In 2010, the BC Government enacted the Clean Energy Act (CEA) (B.C. Ministry of Energy and Mines, 2010) to further encourage large-scale renewable generation projects and conservation programs.

One particular requirement in the CEA is influencing the electricity industry for BC and creating new demand for electricity from within BC. The requirement, in Section 6 of the CEA, is that: “The authority [BC Hydro] must achieve electricity self-sufficiency by holding ...by the year 2016 and each year after that, the rights to an amount of electricity that meets the electricity supply obligations...solely from electricity generating facilities within the Province,..” (B.C. Ministry of Energy and Mines, 2010). To understand more precisely what affect this is having on BC’s electricity industry starts with understanding the electricity supply chain.

#### **2.2. Supply Chain**

Production, delivery and consumption of electricity occur in the following sequence:

- Generation – Electrical generators are the source of the electrical supply. The hydroelectric generator is the most common source for generation in BC and consists of a water wheel coupled to a rotating electrical transformer, which converts mechanical energy to electric energy.
- Transmission – Transmission lines and equipment carry electricity over long distances at high voltages from generators to distribution substations.
- Distribution – Distribution lines and equipment carry electricity over shorter distances at lower voltages from the substation to the consumer’s load.



- Load – The consumer’s load is the final destination for electricity in the supply chain. The load is the equipment that converts electricity into something useful for the consumer, for instance, heat, light, or mechanical energy.

Electrical energy is delivered to a consumer’s load at the instant it is produced by the generator. There is no warehousing or buffering of electricity in the supply chain. Therefore, it is critical for the capacity of the generation, transmission, and distribution system to be capable of supplying all the power at the instant it is needed. The entire supply chain must be big enough to handle the greatest possible demand. This is called the Peak Demand and is measured in kilowatts (kW) or Megawatts (MW). Typically, the time for peak demand is between 4:00 pm and 8:00 pm during very hot or very cold times of the year.

## **2.3. Peak Capacity**

Peak Demand must be matched by the Peak Capacity of the generation, transmission, and distribution system. Otherwise the load must be curtailed to prevent the electrical grid from becoming unstable. Another requirement is that the Peak Capacity of the generation must be dispatchable at the particular time it is needed.

### **2.3.1. Dispatchable Generation**

Dispatchable Generation is an electrical generator that can be ramped up or down very quickly by an operator at any time. The most significant sources of Dispatchable Generation within BC are hydroelectric generating stations that have a reservoir and the Burrard Thermal Generating Station. Operating Burrard Thermal will be prohibited after 2016 (B.C. Ministry of Energy and Mines, 2010), and the most recent large hydroelectric and reservoir project built in BC was the Revelstoke Generating Station, completed in 1984 (Wikipedia, 2015a).

While there have been developments of run-of-river, wind, and solar in BC through the 1990s and 2000s (BC Hydro, 2015a), these are not considered sources of Dispatchable Generation. They are Intermittent Renewables (BC Government, p. 23).

Their dispatch is determined by outside factors that are not under an operator's direct control:

- Run-of-river generation can be dispatched only when the river flows;
- Wind generation can be dispatched only when the wind blows;
- Solar generation can be dispatched only when the sun shines.

For the purpose of this paper, the only sources for Dispatchable Generation within BC are considered to come from large hydroelectric generating stations that have water reservoirs.

### **2.3.2. Curtailable Load**

If the demand for electricity cannot be met by the capacity of the system, then load must be curtailed. One way is to arbitrarily disconnect load. This can upset customers and even present hazards. Another way is through proactive measures called Demand Side Measures (DSMs).

BC Hydro has implemented DSMs before and is further expanding their use but mostly for energy conservation. BC Hydro is also considering a capacity-focused DSM called Curtailable Load (BC Hydro, 2013b), which is new for BC. Curtailable Load is where a consumer sells to the utility the right to curtail the consumer's load. That right gives the utility the ability to reduce demand for one consumer in order to deliver electricity to another. The utility typically pays a flat fee or credit for the year under a contract agreement that specifies the terms for the curtailment. For example, the utility might buy the right to curtail the consumer up to 25 times and for up to 4 hours per occurrence over a year.

The benefit of Curtailable Load to the utility is that it can reduce Peak Demand, allowing the utility to defer capital investments for new Dispatchable Generation. It can also be implemented quickly. Curtailable Load does not reduce total energy consumption over time. It just defers energy usage to time when demand is lower. Ideally, a consumer who can be curtailed will catch up and experience no negative impact overall. Curtailable Load also has environmental benefits by not expending resources to build new generation.

## 2.4. Industry Boundaries

The products, geography, and participants considered in the industry analysis for Peak Capacity are as follows.

### 2.4.1. Products

The product being sold as Peak Capacity is either Dispatchable Generation or Curtailable Load. From the buyer's perspective, BC Hydro's, Curtailable Load has the same effect as Dispatchable Generation by enabling the utility to match supply with demand. The difference is that the former reduces the demand for electricity and the later increases the supply. In this respect, Dispatchable Generation and Curtailable Load can also be considered to be direct substitutes of each other as Peak Capacity.

### 2.4.2. Geography

The projections for Peak Capacity to meet Peak Demand show surplus margins within the United States (US) regions that are connected to BC, otherwise known as the Western Interconnection (see Figure 2.1). In fact, a Peak Capacity surplus is expected to average 44,135 MW from 2015 to 2018 (U.S. Energy Information Administration, 2013).

**Figure 2.1. Projected Generation Supply versus Internal Demand for Western Interconnection**

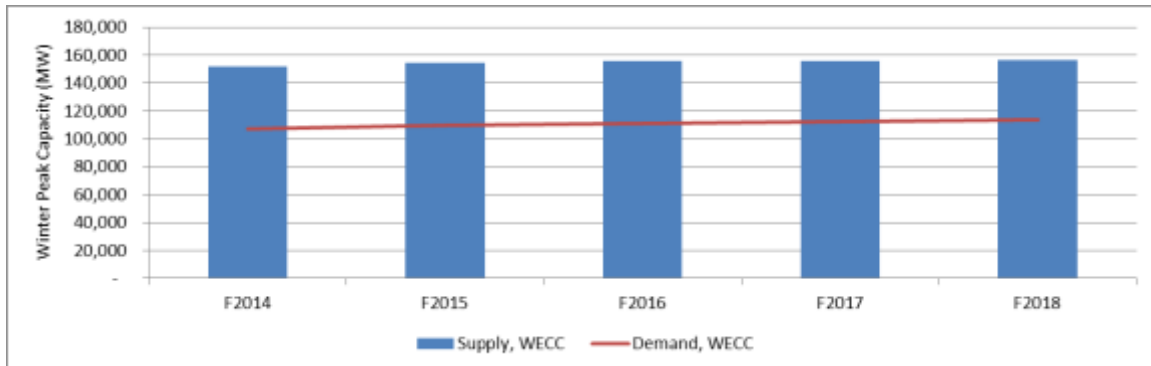

*Note.* Chart produced by author using data from U.S. Energy Information Administration. (2013, December 12). Table 8.9.B. Winter Net Internal Demand, Capacity Resources, and Capacity Margins by North American Electric Reliability Corporation Assessment Area, 2012 Actual, 2013-2017 Projected. Retrieved February 28, 2015, from Demand, capacity resources, and capacity margins: <http://www.eia.gov/electricity/data.cfm#demand>

BC’s electrical system has relied on about 400 MW of US surplus Peak Capacity in the past (BC Hydro, 2013a); however, with the objective of the CEA for BC to achieve electricity self-sufficiency, BC Hydro has been mandated not to rely on imports after 2016 (B.C. Ministry of Energy and Mines, 2010). Because of the BC regulatory objectives, the deficit for Peak Capacity is isolated to BC. Those competing to supply Peak Capacity to BC Hydro would need to be located within BC.

### 2.4.3. Participants

Table 2.1 outlines participants in the Peak Capacity industry in BC. How each influences competition will be explained later in Section 2.5.1 using Porter’s Five Force Analysis.

**Table 2.1. Participants in the Peak Capacity Industry in BC**

<b>Buyers</b>	<ul style="list-style-type: none"> <li>• Crown owned electric utility – BC Hydro</li> <li>• Other public utilities (potentially in the future under the CEA)</li> </ul>
<b>Suppliers</b>	<ul style="list-style-type: none"> <li>• Crown owned electric utility or generation owner – BC Hydro, Columbia Power Corporation</li> <li>• Investor owned electric utilities – FortisBC</li> <li>• Municipally owned utilities – City of Nelson</li> <li>• Private companies with generation assets – Teck, Rio Tinto Alcan</li> </ul>
<b>Competitors</b>	<ul style="list-style-type: none"> <li>• Private companies with generation assets – Teck, Rio Tinto Alcan</li> <li>• Electrolytic-based smelters – Teck, Rio Tinto Alcan</li> <li>• Other large industrial loads – Pulp and Paper Mills, Mines</li> </ul>
<b>Substitutes</b>	<ul style="list-style-type: none"> <li>• New generation – BC Hydro’s Site C, Mica 5 &amp; 6, Revelstoke 6, Waneta Expansion Plant, Independent Power Producers classed as Storage Hydro</li> <li>• Energy conservation – codes and standards, tariffs, education</li> </ul>
<b>New Entrants</b>	<ul style="list-style-type: none"> <li>• Load aggregators – EnerNOC</li> </ul>

## 2.5. Industry Dynamics

This section begins with a look at the industry dynamics using Porter’s Five Force Analysis (Porter, 2008). It concludes with a long term outlook of the market sector.

### 2.5.1. Porter’s Five Force Analysis

Porter’s Five Fore Analysis is used to assess the key drivers and overall strength of each competitive force and has been illustrated diagrammatically in Figure 2.2.

**Figure 2.2. Porter’s Five Forces Model of the Peak Capacity Industry**

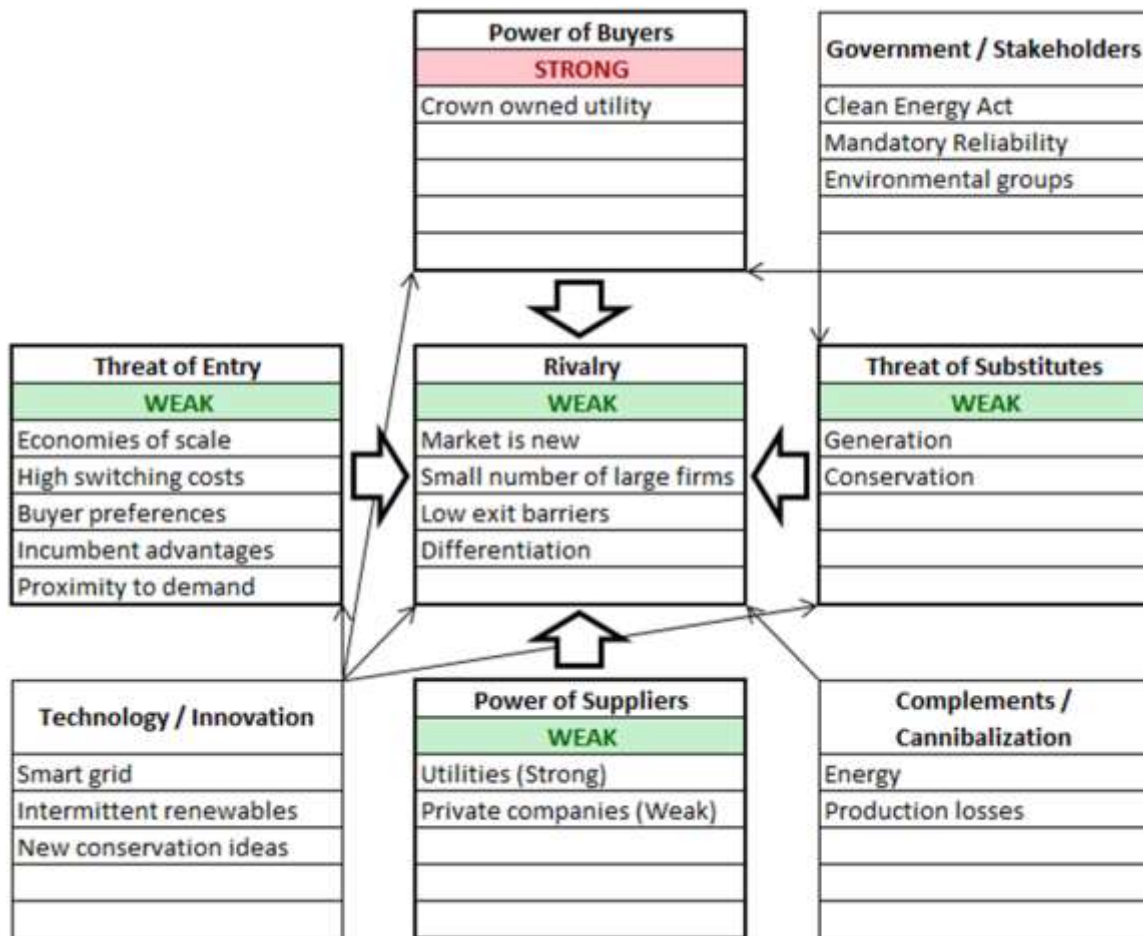

*Note.* Diagram produced by author based on Porter, M. E. (2008, January). The Five Competitive Forces That Shape Strategy. Harvard Business Review, pp. 78-93.

## ***The Threat of Entry***

The threat of other new entrants is weak. At this time, retaliation by competitors is not expected since there is no head to head competition, but the barriers to entry are assessed as follows:

- Supply side economies of scale – Peak Capacity providers must have a large presence on the electrical grid to be of value to the utility. A new entrant would have to have a large hydroelectric station, have a large electrical load, or be an Aggregator of smaller loads (e.g. EnerNOC).
- Demand side benefits of scale - BC Hydro may prefer to deal with existing customers who also purchase energy from them, preferring to enter Curtailable Load agreements with their direct customers as a credit incentive. They may also not want to buy Dispatchable Load from another party if that means redirecting funds from their internal projects.
- Customer switching costs – There are high switching costs for the buyer if he has signed a long term contract agreement for Peak Capacity rights.
- Capital requirements – The capital requirement for new large Dispatchable Generation facilities in BC is massive, \$8.8 billion for Site C (BC Hydro, 2015b). And it would be uneconomical for new entrants to add load to the grid simply for Curtailable Load purposes. The investments in smart grid technology, an operations centre, and marketing for an Aggregator would require moderate capital.
- Incumbency advantage independent of size – Having generation or load that can be dispatched or curtailed at a moment's notice would be an incumbency advantage, especially if the incumbent has excess generation or can make up for the curtailment at a later time.
- Unequal access to distribution channels - The location of the Peak Capacity influences the value of it. If the capacity is not located where it is needed, or the system cannot be balanced to benefit from it, then it is of no value to the utility.

## ***The Power of Suppliers***

The power of suppliers is weak if the Peak Capacity provider generates its own electricity. For instance, the two largest industrial loads in BC (Teck and Rio Tinto Alcan) supply their own electricity. In this case, by curtailing load the entity is actually making available its own Dispatchable Generation to BC Hydro.

In another case, the power of suppliers is very strong if BC Hydro is supplying the electricity already to the consumer and is offering to buy it back as a credit.

### ***The Power of Buyers***

Buyer power is very strong since there is only one main buyer at this time, BC Hydro. Also, Peak Capacity is generally undifferentiated other than the location in the grid where it is made available. Buyer power weakens as the quality and size of the Peak Capacity gets better, i.e. how quickly it can be dispatched, what portion of the BC Hydro's deficit it covers.

### ***The Threat of Substitutes***

The threat of substitutes is weak at this point in time. New Dispatchable Generation in BC is by far the greatest threat to demand for more Peak Capacity in the long run. Generation, particularly from large hydroelectric, is highly dependable and low-cost to operate; however, it is capital intensive, takes time to build, and can impact the environment.

Energy conservation will reduce the amount of Peak Capacity needed in the short and medium terms; however, typical programs are less dependable to a utility for managing Peak Demand compared to a contract for Curtailable Load, or even better, Dispatchable Generation.

### ***Rivalry Among Existing Competitors***

Rivalry among existing competitors is a weak threat. The supply of existing Peak Capacity within BC is small outside of what BC Hydro already owns or has purchased the rights to. BC Hydro already has the capacity and energy rights for all of the generation from Columbia Power Corporation and Independent Power Producers. These entities are not considered rivals unless they can bring new sources of Dispatchable Generation online. Competition to supply existing Peak Capacity is from a small number of single large firms, mostly in the form of Curtailable Load by large industrial loads.

There are only two large electrolytic-based smelters in BC, Teck's Trail Smelter and Rio Tinto Alcan's Kitimat Smelter. Both smelters produce their own electricity supply

but are connected to BC Hydro's grid. The concentration ratio for Teck's Zinc Smelter in Trail is equivalent to 10% of BC Hydro's entire industrial sector in terms of annual energy use. Other competitors include Pulp and Paper Mills and Mines.

Exit barriers are low since since providing Curtailable Load would not be a core function of the business. For instance, the core business of the smelters is to produce refined metal (zinc or aluminum).

There can be a high degree of differentiation in response time and magnitude of curtailment. There can also be differentiation in terms of proximity to demand. Ideally, the load or generator is located near to the region with greatest demand.

## **2.5.2. Factors Affecting Porter's Five Forces (Macro Analysis)**

The following sections focus on the factors that influence the five forces (Porter, 2008), making the Peak Capacity opportunities more or less attractive over time.

### ***Technology and Innovation***

New smart grid technology that enables real-time measurement and control of electrical loads make rivalry and the threat of entry by Aggregators stronger over time. Energy conservation initiatives also make rivalry and the threat of substitution stronger over time.

Adding more generation derived from Intermittent Renewables like wind and solar increases the need for Peak Capacity if there is not enough Dispatchable Generation like large hydroelectric or gas fired turbines, weakening buyer power overtime.

### ***Government and Stakeholders***

The CEA effectively mandates the buyer (BC Hydro) to participate in the market for made-in-BC Peak Capacity, making buyer power weaker.

New hydroelectric development, especially those that dam rivers, could see delays due to opposition from environmental groups, making the threat of substitution weaker or uncertain.



The Mandatory Reliability Standards applicable to British Columbia require the buyer, BC Hydro, to maintain 3% in supplemental emergency reserves, which can be Dispatchable Generation or Curtailable Load. A severe non-compliance to maintain full emergency reserves can result in financial penalties. This factor makes buyer power weaker.

### ***Complements***

If the Peak Capacity provider also produces its own energy and has energy surplus, then the provider could arrange to deliver the energy when called upon to supply capacity. Therefore, the Peak Capacity provider could capture both the curtailment price for the capacity and the peak price for the energy.

### ***Cannibalization***

The ideal scenario for Curtailable Load is to curtail load for a short period when called upon by the utility, then catch up after the curtailment period has ended. In theory, there should be no production loss; however, in reality, curtailing load usually presents some risks and the potential for unrecoverable production losses. A Curtailable Load provider must carefully weigh the cost versus benefit prior to signing a contract with a utility. The cost benefit will vary amongst competitors, which will strengthen or weaken rivalry.

### **2.5.3. Long Run Assessment**

The demand for Peak Capacity in BC for the purpose of ensuring delivery of energy from generation derived within BC is driven by regulation. Over time the demand for Peak Capacity is expected to be met by new Dispatchable Generation, so the need for Curtailable Load to manage Peak Demand will diminish. However, Mandatory Reliability Standards and increased generation from Intermittent Renewables will likely sustain a need for additional sources of Dispatchable Generation and Curtailable Load in the long run.

## 2.6. Gap Analysis

The following gap analysis looks to the most recent Integrated Resources Plan (IRP), published by BC Hydro (BC Hydro, 2013a) to quantify the gap between Peak Capacity and Peak Demand in BC. Following the review of the gap is a review of Manitoba Hydro's Curtailable Rate Program as a basis for assessing a utilities willingness to pay for Peak Capacity.

### 2.6.1. Integrated Resources Plan

According to BC Hydro's IRP, a potential gap between Peak Capacity and Peak Demand begins after Fiscal Year 2015 (F2015) as illustrated in Figure 2.3. The gap is due to the removal of 400 MW of capacity that BC Hydro currently relies upon from external markets to meet Peak Demand. As per the CEA, BC Hydro is no longer supposed to rely on external markets after 2016 because it is not "solely from electricity facilities within the Province" (BC Hydro, 2013a). Without new generation or effective DSM, the gap between supply and demand is expected to be 694 MW by F2017, and 2,385 MW by F2021.

**Figure 2.3. Projected Generation Supply versus Internal Demand for British Columbia**



*Note.* Chart produced by author using data from BC Hydro. (2013, November 15). Appendix 9A: Load-Resource Balances, Base Resource Plans and Contingency Resource Plans. Retrieved February 22, 2015, from Integrated Resources Plan: [https://www.bchydro.com/energy-in-bc/meeting\\_demand\\_growth/irp/document\\_centre/reports/november-2013-irp.html](https://www.bchydro.com/energy-in-bc/meeting_demand_growth/irp/document_centre/reports/november-2013-irp.html)

Within the IRP, BC Hydro lays out a plan to span the gap. The plan includes construction of new Dispatchable Generation, most significantly Site C, and additional DSMs that focus on energy conservation. According to the plans, conservation based DSMs are expected to allow BC Hydro to meet CEA target of a 66% reduction in new energy demand; however, BC Hydro still anticipates a shortfall with the capacity of its generators to deliver energy during peak hours until Site C is completed in 2024. To bridge the capacity gap, BC Hydro has cited in the IRP that it may need external market purchases of up to 300 MW from F2019 to F2023. Since this contradicts the regulatory obligation, one of the recommendations from the IRP is to pursue Curtailable Load beginning in F2015.

## **2.6.2. Willingness to Pay**

Manitoba Hydro has a Curtailable Rate Program (Manitoba Hydro, 2015) that primarily focuses on having Curtailable Load for emergency reserves. Manitoba Hydro's program offers different curtailment options and different credits based on the quality of the curtailment. Most of the options are designed to meet reliability obligations, but one option is designed to manage Peak Demand, similar to what BC Hydro is looking for as one of their options to meet their capacity shortfall.

According to the 2014 Curtailment Rate Program Report to the Public Utilities Board (Manitoba Hydro, 2015), Manitoba Hydro valued Curtailable Load proportionally to the marginal cost of building new long term Dispatchable Generation. The most economical long term generation option to Manitoba Hydro at the time of the report was a Simple Cycle Combustion Turbine (SCCT). For F2014, the carrying cost of an SCCT was estimated to be \$94,000 per MW per year (rounded to the nearest thousand). In their valuation, Manitoba Hydro asserted that Curtailable Load was less valuable than SCCT because it is less flexible to dispatch, has less capability to deliver energy over longer

peak periods, and has no guarantee to be available in the long run. Consequently, Manitoba Hydro gave curtailable load a value of 42% of the annual carrying cost of an SCCT, which equated to \$39,000 per MW per year in F2014 (rounded to the nearest thousand). In F2014, Manitoba Hydro had three customers participating in their program. One was compensated \$5,372,052 in credits and was curtailed 14 times for a total of 15.88 hours for the year. Manitoba paid for the rights to curtail more than that but did not exercise its rights fully.

Looking at Manitoba Hydro's Curtailable Rate Program as proxy to BC Hydro's willingness to pay, the best positioned players to provide Curtailable Load are those who are already direct customers of the utility. Also, to be of value to the utility, the providers need to be able to respond to a curtailment request within ten minutes. Lastly, a consumer who is considering to participate in a Curtailable Rate Program should plan for the worst case of frequency and duration of curtailments as specified in the curtailment agreement, ensuring that in the worst case there is adequate profit with the curtailments. As demonstrated in Manitoba, the frequency and duration of curtailments may be much less resulting in greater profit potential for the Curtailable Load provider.

### **2.6.3. Industry Valuation**

Based on Manitoba Hydro's Curtailable Rate Program and adjusting for 3% inflation, this valuation of Peak Capacity is \$41,000 per MW per year in 2016 dollars. Given the shortfall of 300 MW projected by BC Hydro, the estimate of the total market value in BC from now until 2023 is \$12,300,000 per year (in 2016 dollars).

## **2.7. Summary of Opportunity in the Industry**

In summary, BC Hydro is currently exploring options for Curtailable Load with its customers due to regulatory obligations to achieve electricity self-sufficiency and a projected shortfall of Dispatchable Generation of up to 300 MW before 2024. Using Porter's Five Force Analysis of the situation in BC, this author thinks that the opportunity for providing Curtailable Load or Dispatchable Generation to BC Hydro is favorable. The industry is relatively uncontested except for BC Hydro's position as the primary utility for

the province; however, the Clean Energy Act is prompting BC Hydro to secure more Peak Capacity within BC by 2016. Initially, the price paid by BC Hydro is expected to be \$41,000 per MW per year for Curtailable Load and likely more for Dispatchable Generation.

## Chapter 3.

### Firm Analysis

This analysis of the firm begins with an assessment of how a Zinc Smelter like Teck's Trail Operations earns profit, and how Zinc Smelters in general compete relative to each other. While the intent of this paper is to analyze the potential for Trail Operations to provide Peak Capacity to BC Hydro, it is useful to begin with understanding the primary industry that Teck's Trail Operations competes in as a Zinc Smelter. The intent is to outline the context and factors that must be considered when a Zinc Smelter chooses to make available its Curtailable Load or Dispatchable Generation.

#### 3.1. Financial Analysis

The following discussion draws upon a market analysis by Wood Mackenzie (Wood Mackenzie, 2015). The report outlined the key activities that define the profitability of a Zinc Smelter, in particular operating income (revenue less operating expenses). Supplemental information was also obtained from Wood Mackenzie's Zinc Smelter Cost Model.

To begin, a Zinc Smelter earns revenue through Treatment Charges, Bonus Zinc, and Co-products:

- Treatment Charges are the fees paid by the mines to the smelter to refine the ore concentrate into highly pure zinc metal.
- Bonus Zinc is the additional revenue that comes from extracting more zinc metal from the ore concentrate than the amount that was agreed to be credited to the mine.
- Co-products include all other metals and non-metals that are extracted from the ore concentrate. Co-products are sold by the smelter but may or may not be credited to the mine. The Co-products extracted at Trail Operations include lead, copper, silver, gold, cadmium, indium, germanium, and various sulphur products including sulphuric acid, elemental sulphur, sulphur dioxide, and fertilizer.

On the other side of the equation, operating expenses for a Zinc Smelter are mainly Labour, Energy, Maintenance, Consumables, Onsite Services and Depreciation:

- Labour costs are a function of labour rates and productivity. In regions like Canada, high labour rates can be offset by higher productivity through automation and machinery, keeping labour costs competitive.
- Energy costs are critical for electrolytic-based Zinc Smelters. Having access to cheap and secure energy like hydroelectricity significantly reduces energy costs.
- Maintenance, Consumables, Onsite Services, and Depreciation make up the remainder of Operations Costs. The fact that Trail Operations fairs relatively poorly for expenses for Maintenance, Consumables, and Onsite Services but relatively well for Depreciation is likely a function of the age of the major assets (Plant, Property, and Equipment). Trail Operations has been operating since 1896. Although the major process Plants have been modernized over time, many parts of the operation are still in service beyond the original estimated useful life used for Depreciation.

For the most part, the variable costs per tonne of zinc are low relative to the fixed costs. The ranking for Teck's Trail Operations relative to other firms for 2014 is shown in Table 3.1. The ranking is based on the revenue or operating expenses in cents per pound of zinc.

**Table 3.1. Relative Ranking of Teck's Trail Operations compared to Other Zinc Smelters**

<b>Category</b>	<b>Rank (out of 79)</b>
Overall:	
• Operating Income	5
Revenue:	
• Treatment Charges	37
• Bonus Zinc	14
• Co-products	3
Operating Expenses:	
• Labour	65
• Energy	1
• Maintenance, Consumables, & Onsite Services	70
• Depreciation	5

The rankings above show that Trail earns better than average operating income, ranked 5 out of 79 firms globally. Trail overcomes disadvantages for Treatment Charges, Labour, Maintenance, Consumables, and Onsite Services with advantages in Bonus Zinc, Co-products, Depreciation, and Energy.

Transportation costs are also an important factor for Trail Operations. Trail is located 400 km inland from the nearest seaport. Today, most ore concentrates are shipped from the mines by sea and then hauled by rail and truck from the seaport to Trail. The Transportation costs were not analyzed in the Wood Mackenzie report. However, these costs are significant for Trail and have been factored into Chapter 4, the Opportunity Analysis.

Finally, Trail Operations had one advantage that was ahead of all other competitors in 2014. That was having the lowest Energy costs. The remainder of this Firm Analysis will focus on the operations functions of the value chain, and in particular the activities that make Trail Operations the leader in lowest Energy costs.

## **3.2. Value Chain Analysis**

As a zinc commodity producer, Trail Operations competes on low cost. It competes very little by product differentiation. It produces at low cost primarily through activities in the operations. All other primary and secondary activities are common if compared to other Zinc Smelters, except for inbound logistics where Transportation costs are relatively high because of Trail's inland location.

This Firm Analysis will now shift focus from the Zinc Smelter industry to the Peak Capacity industry in BC. For this it is necessary to examine Trail's core zinc refining process and technology. Trail Operations refines zinc metal from mined concentrates using Roasting, Leaching, Electrowinning, and Melting processes. Between each major process step are storages. Figure 3.1 shows a block diagram of the major zinc refining processes and intermediate storages.



**Figure 3.1. Major Steps for Refining Zinc at Trail Operations**

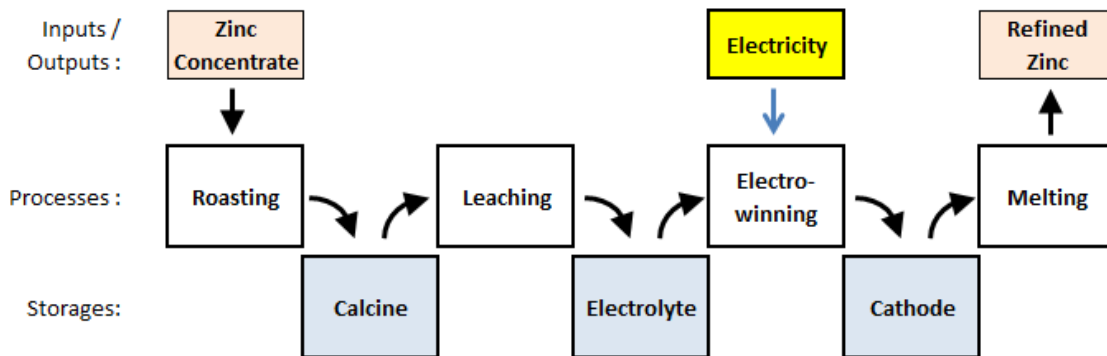

Electricity is a key input to the process step of Electrowinning. At this stage the electrolyte, which contains zinc ions in solution, is pumped between alternating lead anodes and aluminum cathodes. As electric current is applied between the anodes and cathodes, the zinc ions in the electrolyte plate on to the cathode sheets as pure zinc metal. The process is electrically intense, requiring about 3.75 MWh of electricity to produce one tonne of zinc.

The nameplate capacity for Trail Operations is 295,000 tonnes of zinc per year. In order to produce that much zinc, the operation requires 1,106,250 MWh of electricity just for the Electrowinning process. That works out to an average demand of 126.3 MW and is enough electricity to supply the city of Chilliwack, BC<sup>1</sup>.

At this point, it would be easiest to stop the Firm Analysis and conclude that Trail Operations is a strong contender to provide Curtailable Load to BC Hydro simply because the electrical load is very big. However, Trail's unique electrical load is only part of the potential opportunity. Trail's electricity supply is also unique and valuable, not only for Zinc Smelting, but also for possibly supplying made-in-BC Dispatchable Generation to BC Hydro.

<sup>1</sup> Calculation: (1 household / 37 MWh) x (34,340,000 people / 13,320,615 households) x (1,106,250 MWh) = 77,077 people. Refer to Statistics Canada Energy Use Tables (Statistics Canada, 2011).

### 3.2.1. Trail's Electricity Supply

On the surface, one might assume Trail Operations has a competitive advantage as a Zinc Smelter only because it owns a hydroelectric generating station. Further examination of Trail's electricity supply reveals a web of activities and attributes that are more complex and unique than simply owning a hydroelectric generating station. The complex web is essential for providing Trail with its "secure low-cost source of electricity". Figure 3.2 shows an activity map for Trail's electricity supply.

**Figure 3.2. Activity Map for Supplying Electricity to Trail Operations**

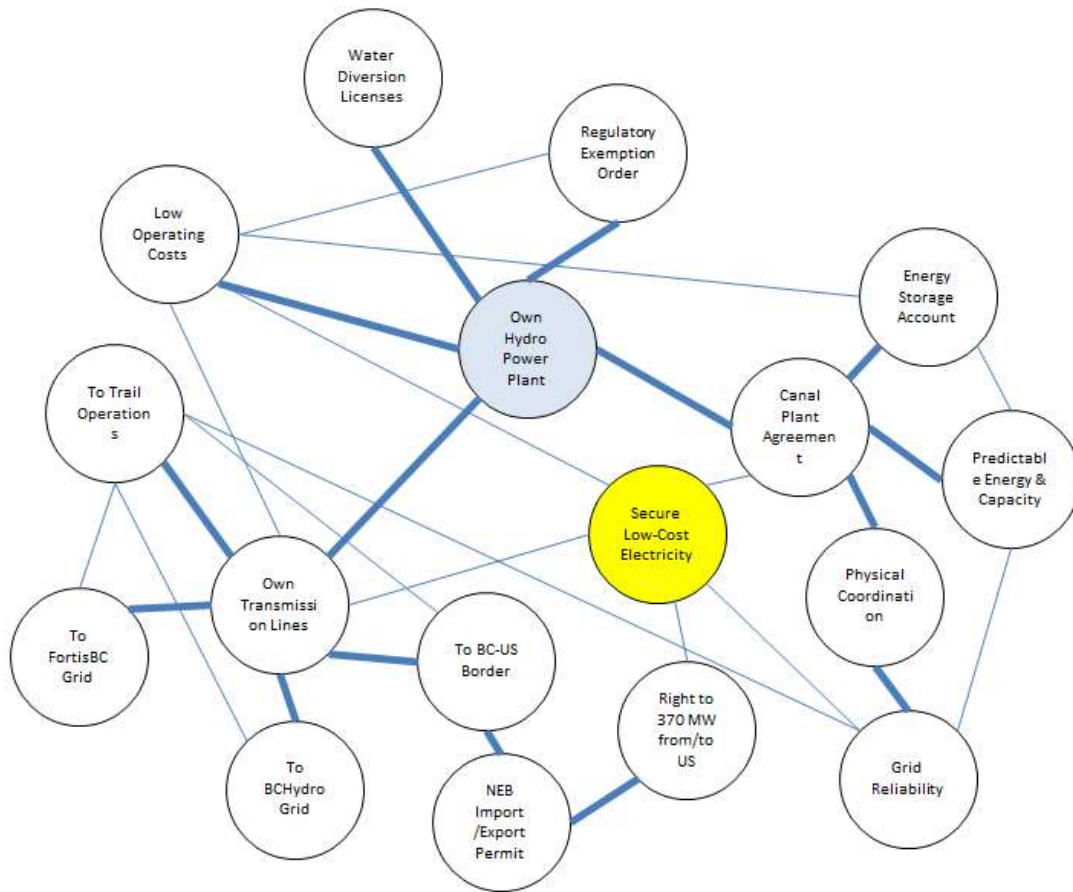

There is no denying that owning a hydroelectric generating station plays a major part; however, a myriad of other activities and attributes are also essential for having a secure source of electricity at a lower cost than its competitors.

First, what really makes a hydroelectric generating station valuable is holding the water licenses on the river for the purpose of generating electricity. Without the licenses, the hydroelectric generating station cannot be built. Furthermore, Teck has direct control over operations, maintenance, and capital expenditures at the generating station through direct ownership of the asset.

Second, Teck owns approximately 45 km of transmission lines and right of ways. A 20 km line connects the generating station to Trail Operations. At that point, Teck also interconnects with the FortisBC grid. Teck owns another 25 km line from the generating station to the US border. A critical attribute of this line is the associated National Energy Board permit that Teck has, which gives Teck transmission rights for firm capacity to either import or export between BC and the US. The transmission line to the US also connects into BC Hydro's grid just before crossing the border.

Finally yet most importantly, Teck is party to the Canal Plant Agreement (CPA). The Agreement was first created in 1972 to facilitate BC Hydro's construction of the Canal Plant on the Kootenay River. At the time, Teck owned four of the five generating stations on the Kootenay River. Since then, the CPA has been expanded. Presently the Agreement includes five parties and covers nearly all generating stations on the Kootenay and Pend d'Oreille Rivers not owned by BC Hydro. The CPA works by each party giving BC Hydro control of their generating stations to dispatch and optimize generation. In exchange, each party receives capacity, energy, and storage entitlements based on historical water flows and generation capabilities of each party's respective generating stations. For Trail Operations, this is extremely useful as capacity, energy, and storage entitlements remain fixed for a thirty year period (subject to penalties for generator or transmission outages). Coordination not only affords optimal efficiency of generation for the province of British Columbia but also reliability by having interconnected resources.

All of the above activities and attributes working in concert are essential for how Trail Operations achieves a "secure low-cost source of electricity" and maintains a competitive advantage as the lowest energy cost producer in the Zinc Smelter industry.

The activities and attributes explained above will be examined further as part of the strengths or weaknesses for Trail Operations to supply Peak Capacity to BC Hydro.

Resources and capabilities related to the zinc refining process will also be explored further from the perspective of supplying Curtailable Load.

### 3.3. Resources and Capabilities Analysis

Certain resources and capabilities that were identified in Section 3.2, Value Chain Analysis, will be explored further in terms of Trail Operations providing Peak Capacity to BC Hydro. The analysis will employ the VRIL Framework (Wikipedia, 2015b). VRIL is an abbreviation for Value, Rarity, Imitability, and Leverage. Each word forms parts of a question used to assess the competitive implication of a particular resource or capability:

- *Value?* Can the resource or capability provide value to the firm? I.e. can it increase Return on Capital Employed?
- *Rarity?* Is the resource or capability scarce? How unique is it amongst competitors?
- *Costly to Imitate?* Is the resource or capability costly or difficult to duplicate? Can it be substituted?
- *Leveraged?* Is the firm ready and able to capture value using the resource or capability?

The next subsections describe each resource or capability considered for Peak Capacity, including the VRIL Framework analysis. Section 3.4 contains a summary table of the results.

#### ***Very large industrial electrical load***

The electricity load for Trail Operations is very large relative to the load in the rest of the province. Having this resource to participate in a Curtailable Load program is a competitive advantage and a potential strength for Trail.

VRIL Analysis:

- *Value?* Yes – The load is big. In fact, the Trail Zinc Smelter is second only to the Aluminum Smelter and utilizes electricity equivalent to about 10% of BC Hydro's total industrial load. The reason the load is so big is primarily due to the Electrowinning process. The process alone consumes enough electricity to supply the city of Chilliwack, BC. Curtailing Trail's Electrowinning process could meet 50% of BC Hydro's projected capacity shortfall.

- *Rarity?* Yes - In the context of Peak Capacity, Trail Operations is valuable because of its size. It is also rare. Only one other single load in BC is bigger.
- *Costly to Imitate?* Yes - No firm would add electrical load to the system for the sole purpose of supplying a market for Curtailable Load. If anything, new generation would be added. As already indicated in BC Hydro's IRP, new generation cannot be built soon enough before the capacity is needed in BC. That said, there are companies, like EnerNOC, that aggregate many small loads and coordinate curtailment. This would be a more costly, but not unreasonable, to pay for network communications equipment and overhead for managing a Network Operations Centre.
- *Leveraged?* No –Trail Operations has curtailed zinc production and sold electricity instead in the past. It did this in 2001 when energy prices were high and in 2009 when the zinc market was weak. In both cases, the curtailments were planned well in advance and lasted for many weeks. Trail Operations has not participated in a Curtailable Load program; that is, curtailing production on short notice and for short periods for the purpose of freeing up generation on the system in a long term arrangement.

### ***Capability to ramp up/down a large portion of load quickly***

Another important capability for Trail Operations is that the Electrowinning process can be ramped up or down very quickly. Theoretically, it is as simple as turning a dial. Trail's capability to curtail load quickly is neither a strength nor a weakness in the context of Curtailable Load, but it does keep Trail a contender as a suitable participant.

VRIL Analysis:

- *Value?* Yes – While theoretically easy to do, curtailing the Electrowinning process gets practically more difficult as the magnitude or duration increases and if operations are unprepared. Risks of large or extended curtailments that are unplanned include overflowing storages, plugging process pipes, and damaging electrolytic cells. However, if operations are prepared and the duration of curtailment is short then these risks can be managed.
- *Rarity?* No - This capability would not be rare amongst other industrial loads, although curtailing a Zinc Smelter is typically easier than curtailing an Aluminum Smelter. Typically, other electricity consumers can turn on or off loads relatively easy if motivated.

### ***Zinc and co-products available in the market***

Zinc and the various co-products produced by Trail Operations are commodities. This is neither a strength nor a weakness for Trail to supply Curtailable Load, keeping Trail at competitive parity with other load curtailment providers.

VRIL Analysis:

- *Value?* Yes - As long as market inventories are adequate, Trail's products could be purchased from elsewhere to meet contract obligations if curtailment results in unrecoverable production losses. As long as the price paid to curtail covers the cost to replace lost production through market purchases, then having the capability to buy from the market provides value.
- *Rarity?* No - Others competing for Curtailable Load opportunities may or may not produce commodities and may or may not lose production forever. Although valuable for Trail in the context of Curtailable Load, this would not be rare. It would be a way for Trail to mitigate risk of unrecoverable production losses caused by load curtailment.

### ***Own hydroelectric generation in BC***

A very special resource for Trail Operations is owning a hydroelectric generating station within BC, in particular for supplying Peak Capacity to BC Hydro to use. It is a competitive advantage for Trail and a strength.

VRIL Analysis:

- *Value?* Yes - Physically, when Trail Operations curtails load, generation from its station becomes available for another party to use.
- *Rarity?* Yes - This resource is rare for an industrial consumer. The only other industrial load that possesses its own large hydroelectric station in BC is the Aluminum Smelter.
- *Costly to Imitate?* Yes - Imitating this resource is nearly impossible nowadays, given scarcity of suitable locations for large hydroelectric facilities and the fact hydroelectric facilities are highly regulated and rarely for sale.
- *Leveraged?* No - Currently Trail Operations does not make its generation available to other parties for the purpose of meeting peak demand or as substitute for Curtailable Load.

### ***Own transmission links to BC and US utilities***

Another very unique resource for Trail Operations is its transmission network. It is a strength for Trail Operations and a competitive advantage for supplying Peak Capacity.

VRIL Analysis:

- *Value?* Yes - Although very short with a total distance covering 45 km, Trail's transmission lines are in important locations. One 20 km long section runs west from the Waneta Generating Station to Trail Operations, at which point

the system also interconnects with the FortisBC grid. Running east from the Waneta Generating Station, a 25 km section links to the Bonneville Power Administration's grid at the US border. Just before the border, the line also interconnects with BC Hydro's transmission system. The connections are extremely valuable in making the physical impact of curtailed load or surplus generation from Waneta available to either BC Hydro or to FortisBC.

- *Rarity and Costly to Imitate?* Yes - Not only does no other industrial load in BC have this, but no other firm could replicate this without extraordinary costs to buy right of ways and to build transmission infrastructure.
- *Leveraged?* No - At this time, Trail Operations does not leverage this resource for the purpose of making peak capacity available to either FortisBC or to BC Hydro.

### ***Zinc Smelter operates at full capacity***

The Electrowinning process at Trail runs at full capacity except during process upsets and maintenance shutdowns. This aspect is a competitive disadvantage for Curtailable Load when compared to others that have catch up capacity.

VRIL Analysis:

- *Value?* No - Trail has no catch up capacity. If there is a call to curtail production to free up Peak Capacity, then unrecoverable production losses will most likely occur. That will be a cost for Trail. The only way for it to be of value would be for the price for curtailment to outweigh the costs of lost production. The costs would have to consider the lost margin for each tonne of lost zinc and co-product, any risks to equipment associated with curtailment, and any penalties for not meeting sales obligations.

### ***Not a direct customer of a public utility***

Because Trail Operations owns and operates its own generation and transmission system, Trail Operations is not a direct customer of any public utility. Overall, this is a competitive disadvantage for Trail Operations and considered a weakness if competing against direct customers of the public utilities for Curtailable Load opportunities.

VRIL Analysis:

- *Value?* No - Trail Operations would not be considered as part of the existing load base of BC Hydro. BC Hydro has neither approached nor likely considered Trail Operations as an option to their approaching problem of a capacity shortfall. BC Hydro may also be less inclined to pay the curtailment rate to a non customer. Existing Curtailment Rate Programs, like Manitoba

Hydro's, offer a credit to their customer. They do not make a payment. Trail Operations would not be eligible to participate directly in BC Hydro's Load Curtailment Program. Teck and BC Hydro would need to negotiate a different kind of agreement. The agreement would actually be to make generation capacity from Waneta to be available to the utility though curtailing the electrical load at Trail Operations. On the flip side, this could be an attractive option to the utility since it means the utility would not need to inconvenience any of its direct customers by asking them to curtail.

### 3.4. Summary of Strengths and Weaknesses of Firm in the Industry

Table 3.2 contains a summary of strengths and weaknesses for Trail Operations to consider in offering Peak Capacity options to BC Hydro, based on the discussion in Section 3.3 Resources and Capabilities Analysis.

**Table 3.2. Summary of Trail Operations' Strengths and Weaknesses for Providing Peak Capacity to Public Utilities**

Resource / Capability	Value?	Rarity?	Costly to Imitate?	Lever-aged?	Competitive Implication	Strength / Weakness
Very large industrial electrical load	Yes	Yes	Yes	No	Advantage	Strength
Capability to ramp up/down a large portion of load quickly	Yes	No			Parity	Neither
Zinc and co-products are commodities	Yes	No			Parity	Neither



<b>Resource / Capability</b>	<b>Value?</b>	<b>Rarity?</b>	<b>Costly to Imitate?</b>	<b>Lever-aged?</b>	<b>Competitive Implication</b>	<b>Strength / Weakness</b>
Possess hydroelectric facility and energy storage capability	Yes	Yes	Yes	No	Advantage	Strength
Own transmission access to 2 BC public utilities and to the US market	Yes	Yes	Yes	No	Advantage	Strength
Zinc Smelter operates at full capacity	No				Disadvantage	Weakness
Not a direct customer of any BC public utility	No				Disadvantage	Weakness

### **3.5. Opportunity Statement**

Teck's Trail Operations is uniquely positioned to provide Peak Capacity options to BC Hydro. Being the second largest single electrical load in British Columbia and having the ability to instantly ramp up or down a large portion of its electrical load, Trail may be able to effectively free up Peak Capacity on the grid if called upon without requiring additional capital investment. Curtailing load is not without a cost to Trail Operations. Doing so can result in unrecoverable production losses and potentially puts process equipment at risk. Alternatively, Trail Operations may be better off exploring its capability

to free up Dispatchable Generation from the Waneta Generating Station for BC Hydro to use. The remainder of the paper will identify and evaluate alternatives further.

## **Chapter 4.**

### **Opportunity Analysis**

This Chapter will explore three alternatives for Teck to supply either Dispatchable Generation or Curtailable Load to BC Hydro for the purpose of meeting their regulatory obligation to be electricity self-sufficient by 2016.

#### **4.1. Alternatives**

Three alternatives are considered:

1. Offer Surplus Generation Up to 10 MW
2. Offer Curtailable Load Up to 32 MW
3. Offer Generation Swap Up To 225 MW

Each is explained more fully in the following sections 4.1.1 to 4.1.3.

##### **4.1.1. Alternative 1: Offer Surplus Generation Up to 10 MW**

Despite selling most of its surplus electricity to BC Hydro in 2009 (Teck Resources Ltd., 2009 ), Trail Operations retains a small amount of residual surplus generation capacity. Currently, Trail Operations utilizes this surplus capacity to schedule sales of surplus energy. The surplus capacity averages 10 MW in the winter, when the need for Peak Capacity in BC is expected to be greatest.

Offering surplus capacity rights means there is no impact to metal production for Trail Operations, assuming production levels stay the same as today. For this alternative, the cost to Trail Operations would be the opportunity cost of not using that capacity to sell surplus energy to the market. During the time of the day when Peak Capacity would typically be required, the price Trail Operations could get for the electricity would be the Mid-Columbia (Mid-C) On-Peak price minus the cost of transmission (\$4.00 per MWh). If the electricity could not be sold during On-Peak, it could be sold later that night during the

Off-Peak hours. Therefore, the lost opportunity cost for Trail Operations of not using the surplus Peak Capacity would be the difference between the On-Peak and Off-Peak prices. The lost opportunity cost would be as follows:

- Willingness to Pay (2016): \$41,000 / MW for 1,600 hrs of curtailment rights
- Mid-C On Peak (2016): \$28.40 / MWh
- Mid-C Off Peak (2016): \$22.55 / MWh
- Opportunity Cost:  $(\$28.40 - \$22.55) / \text{MWh} = \$5.85 / \text{MWh}$

Assuming a curtailment contract restricts the number of curtailment hours to 1,600 hours per year (the number of On-Peak hours from November to February) then additional revenue for Alternative 1 amounts to

- $[\$41,000/\text{MW} - (\$5.85/\text{MWh} \times 1,600 \text{ hrs})] \times 10 \text{ MW} = \underline{\$316,400}$  per year

#### **4.1.2. Alternative 2: Offer Curtailable Load Up to 32 MW**

The next alternative considered is to offer Curtailable Load. Peak load for Trail Operations is 225 MW. If there was a call to curtail load below peak then the assumption is that unrecoverable metal production losses will result. The reason is that the Zinc Electrowinning process runs at full capacity whenever possible and can be considered the bottleneck for metal production. If the production is curtailed for electrical load curtailment, then electricity used for Electrowinning will be trimmed back. Any time electricity is trimmed, zinc production is lost.

Given the assumption that a call to curtail below peak demand means unrecoverable zinc production losses, then Trail's Curtailment Price Model must be used to determine the cost.

#### ***Trail's Curtailment Price Model***

A Curtailment Price Model has been developed for Trail Operations. The latest revision by Bill Van Beek, Teck Metals Ltd. is discussed in this analysis. The basis of the model will be explained for the purpose of this paper, but specific details are left out or modified intentionally for confidentiality reasons.

The current Curtailment Price Model calculates an energy price that is equivalent to the incremental gross profit margin of producing and selling one more tonne of zinc. The current model includes the following revenues and costs:

- Revenues: Sales Price for Zinc, Sales Price for Co-products, Treatment Charge
- Variable Costs: Sales and Distribution, Consumables, Concentrate Transportation, Credit to Mine

Given current prices and costs, the model calculates a gross profit margin per tonne of zinc, excluding the incremental cost of electricity. The Gross Margin is multiplied by the electricity intensity value for zinc of 3.75 MWh/tonne. The resulting Curtailment Cost for Trail Operations for 2016 is \$200 per MWh. That cost represents the lost opportunity cost of not producing and selling the equivalent in Zinc and Co-products.

The model described above also assumes every tonne more of zinc can be sold without a negative effect on pricing. In other words, there is no sales constraint on zinc. In some cases, such as during the the global economic downturn of 2008/2009, zinc production was curtailed by 20% at Trail Operations in order to help preserve balance between supply and demand (Barnes, 2008).

Also, another assumption in the model is that there is no penalty cost for the curtailment. While this is generally true for curtailments of shorter durations and smaller magnitudes, i.e. reducing spot market sales, this may not be true for curtailments that result in failure to meet contract obligations. One of Trail's strengths, as identified in Chapter 3, was that the primary products from Trail are commodities. If contract orders still needed to be fulfilled then it is reasonable to assume that zinc could be purchased from the market. In general this holds true when inventories are healthy and located near to where the product needs to be delivered. In some cases, it may require going to a special supplier who demands a premium for a specific shape or alloy, or it may require additional transportation costs if the product is not available in the vicinity needed. Therefore, penalty costs should be considered in addition to the Curtailment Costs in situations of longer curtailments and when market inventories are low.

### ***Expected Value of Load Curtailment***

For the purpose of this analysis, it will be assumed that a Load Curtailment contract restricts the number of curtailment hours to 120 hours and for no longer than 4 hours per day. Given that, the potential for contract penalty costs may be ignored and only the Curtailment Cost will be used.

Another consideration is the amount of electricity to curtail. The Electrowinning process consumes about 126 MW (58%) of Trail's peak load. The remainder is consumed by other pieces of electrical equipment like pumps, compressors, lighting and lead furnace. The assumption in this analysis is that only the Electrowinning process will be curtailed since it is the single biggest and easiest load to curtail at Trail Operations. All 126 MW is controlled by four large rectifiers, which can be trimmed from 0% to 100% with a turn of the dial. This load is the only load that can effectively be curtailed within the ten minute time limit required by the public utilities.

In addition, curtailing each rectifier to zero can cause process problems later if the cellhouses are not emptied of electrolyte. Emptying the electrolyte takes longer than ten minutes so doing so does not meet the criteria for Curtailable Load. More reasonable is to expect that each rectifier can be curtailed by up to 25% for up to 4 hours without adverse effects. That means Trail Operations could consider offering up to 32 MW below peak load.

- Willingness to Pay (2016): \$41,000 / MW for 120 hrs of curtailment rights or \$342 / MWh
- Opportunity Cost = Curtailment Cost (2016) = \$200 / MWh

Assuming a curtailment contract restricting the number of curtailment hours to 120 hours per year, then additional revenue for Alternative 2 amounts to

- $(\$342/\text{MWh} - \$200/\text{MWh}) \times 32 \text{ MW} \times 120 \text{ hrs} = \underline{\$545,280}$  per year

#### **4.1.3. Alternative 3: Offer Generation Swap Up To 225 MW**

The third alternative comes by looking beyond surplus generation and the industrial load for options for freeing up Peak Capacity for BC Hydro. This option looks

deeper into the the real constraints on the system and the underlying factors driving BC Hydro to consider Curtailable Load.

Trail Operations has a number of strengths that could be further utilized to make made-in-BC generation available to BC Hydro. Trail could offer to swap its generation with BC Hydro’s market purchases, i.e. imports from the US. See Figures 4.1 and 4.2.

**Figure 4.1. Typical Power Flow on Teck’s Power System**

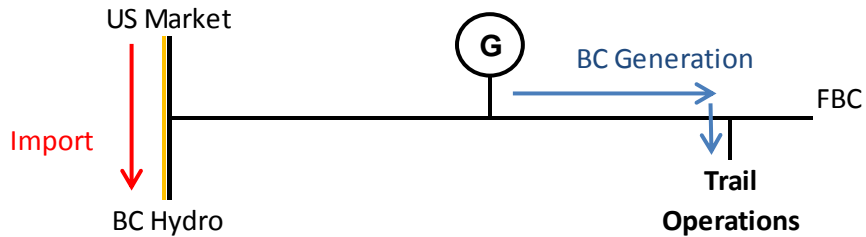

**Figure 4.2. Power Flow on Teck’s System during Swap**

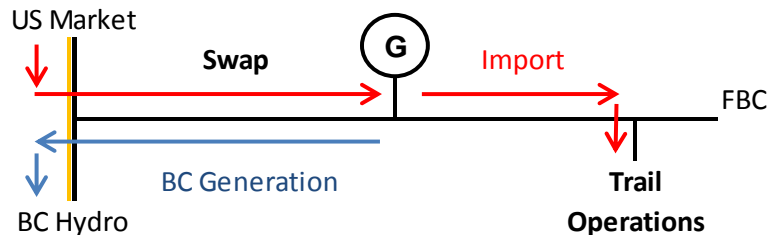

The idea of the Generation Swap would be for Teck to agree to accept the US market purchases during times when BC Hydro needs it to meet Peak Demand. The expectation would be for the public utility to take care of the transmission scheduling. Trail could offer up to 225 MW of Dispatchable Generation to be available for a swap since no curtailment of load is required. Trail Operations would simply continue to run on imported generation instead of its own generation. The benefit to the utility is that the swap could happen instantly (no 10 minute response delay) and the number of curtailment hours could be unlimited, assuming Teck’s generation was available. Also, the quantity of 225 MW meets 75% of the BC Hydro’s projected shortfall. Lastly, it would take the pressure off the utility to try to make up for the shortfall by more costly means such as installing pumped storage. For Teck, the swap would result in an increase in water rental fees for power generation, which is included in the calculation below:

- Willingness to Pay (2016): \$41,000 / MW
- Water Rental, Capacity: \$4.334 - \$2.165 / MW = \$2.169 / MW
- Water Rental, Energy: \$6.066 - \$1.301 / MWh = \$4.765 / MWh
- Water Rental Cost: (\$2.169 / MW / 240 hrs) + \$4.765 / MWh = \$4.774 / MWh assuming swaps for 240 hours per year

Additional revenue for Alternative 3 could amount to

- $(\$41,000/\text{MW} \times 225 \text{ MW}) - (4.77/\text{MWh} \times 54,000 \text{ MWh}) = \underline{\$8,967,200}$  per year

## 4.2. Evaluation

The alternatives described in Chapter 4.1 are not necessarily exclusive of each other. It may be possible to implement combinations such as Alternative 1 (Generation Surplus) and Alternative 2 (Load Curtailment) or Alternative 1 (Generation Surplus) and Alternative 3 (Generation Swap); however, for the purpose of this evaluation each alternative will be analyzed as standalone.

The evaluation methodology follows a Kepner-Tregoe Decision Analysis (Kepner & Tregoe, 1997). Refer to Table 4.1 for a summary of the analysis. The evaluation criteria was developed by looking forward in time as if the decision had already been made, and Trail was reflecting upon what was achieved with the decision. One year from now, assuming the decision has been made and implemented, the alternative that is best for Trail Operations is the one that most optimally satisfies the following criteria:

1. Must be compliant with the BC Clean Energy Act
2. Should reduce Teck's energy consumption and greenhouse gas emissions
3. Should increase Teck's profitability
4. Should be the most flexible to dispatch
5. Should have the least impact on metal production

The first criterion is that the alternative must be compliant with the Clean Energy Act (CEA). All three of the alternatives meet the main requirement by making made-in-BC generation available to to BC Hydro. As Section 6 of the CEA states "The authority [BC Hydro] must achieve electricity self-sufficiency by holding, ...by the year 2016 and each



year after that, the rights to an amount of electricity that meets the electricity supply obligations...solely from electricity generating facilities within the Province,..". For clarification, Teck is not a public utility and is not obligated under the CEA to utilize made-in-BC generation exclusively.

The second criterion is that alternative should reduce Teck's energy consumption and Greenhouse Gas (GHG) emissions. The reason for this criterion is that Teck has as Strategy for Sustainability (Teck Resources Ltd., 2014) and has set goals for energy and GHG reductions. The 2015 goals were (1) to reduce energy consumption at existing operations by 1,000 terajoules, (2) to reduce greenhouse gas emissions at existing operations by 75 kilotonnes of carbon dioxide equivalent emissions (CO<sub>2</sub>e), and (3) to commit to 30 megawatts (MW) of alternative (non-carbon-emitting) energy generation. Alternative 1 (Generation Surplus) has no effect on Teck's energy or GHG goals. Alternative 2 (Load Curtailment) would reduce energy consumption at Trail Operations but only because production would be curtailed. In other words, the reduction would not be due to an efficiency gain. Alternative 3 (Generation Swap) does not affect energy consumption but would increase the reportable GHG emissions from Trail Operations. Here's why. Presently, Trail Operations reports that 100% of electricity consumed comes from hydroelectricity, a renewable resource with zero GHG emissions. Trail would need to report GHG emissions related to the electricity imports because it would need to assume that peak generation is being supplied by natural gas powered turbines. Under the Generation Swap, Trail could end up reporting up to 3% of its electricity is derived from fossil fuels and the emissions of associated by products (CO<sub>2</sub>, SO<sub>2</sub>, NO<sub>x</sub>, CO, particulate matter, mercury). For this particular criterion, Alternative 2 (Load Curtailment) is the most attractive.

The third criterion is that the alternative should maximize Trail's profitability. Alternative 1 (Generation Surplus) contributes the lowest profit increase of \$316,400 per year. Alternative 2 (Load Curtailment) has a slightly better profit increase of \$545,280 per year, which is only 70% more than Alternative 1 even though the volume is 220% more (32 MW compared to 10 MW). Alternative 3 results in a profit increase of \$8,967,150 per year and alone would satisfy 75% of BC Hydro's projected shortfall. It is also the lowest

cost of the alternatives for Trail Operations at \$4.774/MWh. Alternative 3 is by far the most attractive for increasing profit.

The fourth criterion is that the alternative should be the most flexible to dispatch. That means it should be quick and available for the greatest number of hours in the year and for the longest duration. Alternative 1 (Generation Surplus) could be made available to the utilities instantly and be highly reliable because the capacity would be held on reserve. Teck would agree not to sell surplus energy during On-Peak hours from November to February. The duration would be limited to 16 hours per day, which is the fixed duration for On-Peak hours. Alternative 2 (Load Curtailment) is less convenient and possibly less dependable because it requires a phone call from the utility's dispatcher to the plant control room at Trail Operations to initiate curtailment. Typically curtailment takes up to 10 minutes, and there is a chance it could not be done because of process constraints. Alternative 2 (Load Curtailment) would also have tighter limits on the curtailment periods, a maximum of 120 hours/year and for no more than 4 hours per occurrence. Alternative 3 (Generation Swap) would be the most convenient to dispatch. The generation could be available instantly and managed by the utilities' power marketer. The only restrictions on the marketer would be to schedule the market purchase to the eastern US-BC intertie and that generation was available at the Waneta Generating Station. From Trail's perspective, there would be no need to limit how often Alternative 3 (Generation Swap) gets exercised other than how much reportable GHG emissions Trail would be willing to accept. Therefore, Alternative 3 is the preferred choice for ease of dispatch.

The fifth criterion is that the alternative should have the least impact on metal production. Trail's core business is still to make zinc, not to sell electricity. The best alternative should have the least impact on metal production at Trail Operations. Alternatives 1 (Generation Surplus) and 3 (Generation Swap) have no impact, while Alternative 2 (Load Curtailment) has some impact, up to 1,024 tonnes per year, which is equivalent to 0.5% of annual production. Alternative 2 (Load Curtailment) would also require a change for operations personnel to respond quickly to calls to curtail. Consideration for management of change would be needed. Alternatives 1 (Generation Surplus) and 3 (Generation Swap) have the least impact on production.

In Table 4.1, each alternative had been scored (S) in terms of how well each performs against the criterion, as described in the preceding paragraphs. Scores are allocated from 0 through 10 with 10 being the best. It should be highlighted that the numbers have mostly subjective meaning and should not be interpreted as having much objective significance. Assigning the numbers is simply a way of breaking apart the various aspects of the decision and organizing the information in some sort of pseudo-objective way. It is intended to provide a framework for discussing the basis for the decision with other stakeholders.

The final step is calibrating the significance of the five criteria relative to each other by assigning each one a weight (W). Weights are allocated from 1 through 10 with 10 signifying greatest importance. M is used to signify when the criterion must be met. Like the scores, the weights have mostly subjective meaning. They should not be interpreted as having much objective significance.

The weights have been allocated by the author amongst the criteria 2 to 5 to be consistent with Teck’s Business and Sustainability Strategy: “Financial performance and a company’s ability to implement its sustainability strategy are interdependent. Strong financial performance enables us to better manage our business, including our economic, social and environmental performance...Our financial capacity will determine how far and how fast we can move forward to achieve our goals...” (Teck Resources Ltd., 2014, p. 17). The weighting allocation is this author’s interpretation of Teck’s approach to balancing business, environmental and social goals. More specifically, meeting Teck’s energy use and GHG emissions reduction goals have been given 50% of the total weighting while the remaining 50% has been distributed amongst the profitability and operational criteria.

**Table 4.1. Evaluation of Alternatives**

Evaluation Criteria			Alternative 1: Generation Surplus			Alternative 2: Load Curtailment			Alternative 3: Generation Swap		
#	Description	W	Comment	S	WS	Comment	S	WS	Comment	S	WS
1	Compliant with Clean Energy Act	M	Yes			Yes			Yes		

Evaluation Criteria			Alternative 1: Generation Surplus			Alternative 2: Load Curtailment			Alternative 3: Generation Swap		
2	Reduces Teck's energy use or GHG emissions	10	No change	5	50	Yes – reduces energy because production is curtailed	8	80	No – increases reportable GHG emissions	1	10
3	Increases Profit	5	\$316,400	1	5	\$545,280	2	10	\$8,967,200	10	50
4	Least Restrictions to Dispatch	3	Instant, 1,600 hours/year, 16 hours/event	6	18	10 minute delay, 120 hours/year, 4 hours/event	3	9	Instant, No maximum limits	10	30
5	Least Impact to Production	2	No impact	10	20	Impact – curtailment of zinc production by up to 1,024 tonnes per year, management of change	1	2	No impact	10	20
<b>Sum of Weighted Scores:</b>					<b>93</b>			<b>101</b>		<b>Best</b>	<b>110</b>
<u>Legend</u>											
W Weight											
S Score											
WS Weighted Score (WxS)											
M Must											

### 4.3. Recommendation

Alternative 3 (Generation Swap) stands out as the optimal choice for Trail Operations; however, it would a choice that makes a trade-off. The trade-off is between

profitability for Trail Operations and reportable GHG emissions. The trade-off is not trivial. Increasing reportable GHG emissions goes against Teck's established GHG reduction goal. However, the potential to increase profitability of Trail Operations by almost \$9 million per year for Trail is also significant. To put it in perspective, gross profit for Trail Operations in 2014 was \$76 million (Teck Resources Ltd., 2015, p. 28). The additional contribution from a Generation Swap means an immediate 12% increase, with no capital expenditure. Furthermore, the additional revenue would increase Trail's financial capacity to fund other social and environmental improvement projects. Thus, this author recommends for Teck to consider offering a Generation Swap to BC Hydro.

## **Chapter 5.**

### **Implementation**

The recommendation to offer the Generation Swap of Up to 225 MW to BC Hydro requires no organizational change within Teck. The challenge in implementation will be negotiating with internal stakeholders and inducing the interest of BC Hydro.

#### **5.1. Internal Stakeholders**

The first step is to discuss the idea internally at Teck, in particular with Environment and Public Affairs representatives. Their support is needed given the trade-off between reportable GHG emissions and increasing profitability. The first task will be to calculate exactly how much reportable emissions will change if Trail's electricity consumption profile changes from 100% hydroelectricity to 97% hydroelectricity and 3% derived from fossil fuels.

Regardless of how big the increase will be, this author anticipates that there will be pushback because it goes against one of Teck's Strategy for Sustainability goals. As stated in Section 4.4, one reason to proceed is that the additional revenue from a Generation Swap will increase Trail's financial capacity to fund other social and environmental improvement projects such as Trail's Smelter Recycles Building (Teck Metals Ltd., 2014) and Ground Water Treatment Plant (Teck Metals Ltd., 2015). Looking at it as a balanced approach is consistent with Teck's overall Business and Sustainability Strategy (Teck Resources Ltd., 2014).

In addition, another project could be considered to offset the GHG increase. For example, a portion of the additional profit could go to funding the installation of Microhydroelectric Turbines on the raw water outflows at Trail Operations (Appendix A). This project has been uneconomical to justify in the past using market electricity prices. The installation cost for turbines is roughly \$1.5 million, but they have the potential to reduce energy use by 90,000 MWh over their lifetime. Using a portion of the revenue

from the Generation Swap for conservation projects like the Microhydro Turbines is actually better than Alternative 2 (Load Curtailment) because it results in a sustained efficiency improvement.

## **5.2. External Stakeholders**

If the idea is endorsed internally, then the idea can be floated to BC Hydro. The challenge at this step is to induce their interest. The incentive programs being developed by BC Hydro for Curtailable Load are aimed at their direct customers (BC Hydro, 2014). Why would they want to engage with an outside party?

The author's answer is that it is the best alternative for BC Hydro to meet their capacity shortfall in the short term. The deal would provide them with:

- Rights to 225 MW of additional made-in-BC generation during peak demand
- A cheaper and quicker alternative compared to capital projects
- A more dependable and convenient alternative compared to load curtailment

Teck would need assurances that electricity supply to Trail Operations would not be interrupted, and BC Hydro's electricity marketer would need take care of the swaps in real time at no cost to Teck.

If they are interested, then the next step is to negotiate a contract. On both sides, development of the contract would involve legal counsel. It would also require a review of existing transmission and generation contracts to ensure there is nothing that conflicts with a Generation Swap arrangement.

The bulk of the effort in implementing the Generation Swap is contract reviews and negotiation. There is no organizational change, so no management of change effort is required. However, Teck should be prepared to manage external stakeholder perceptions. Even though Teck is not a public utility, the deal would be made with a public utility so aspects would be made public and scrutinized. Teck should be prepared to respond to inquiries from the public and the media.





## **Chapter 6.**

### **Conclusion**

In conclusion, BC Hydro is currently exploring options for increasing its Peak Capacity due to regulatory obligations to achieve electricity self-sufficiency and a projected shortfall of generation capacity of up to 300 MW before 2024. Using Porter's Five Force Analysis of the need for Peak Capacity in BC, this author thinks there could be a commercial opportunity to provide BC Hydro with Curtailable Load or Dispatchable Generation. Initially, the price paid is expected to be \$41,000 per MW per year for Curtailable Load and likely more for Dispatchable Generation.

The genesis for this strategic analysis was to consider the opportunity for Teck's Trail Operations to provide Curtailable Load to BC Hydro. After reviewing the strengths and weaknesses of the firm, it became evident that Trail could offer other alternatives to the utility that were more dependable and convenient. The two additional alternatives were to offer Trail's Generation Surplus or to swap BC Hydro's imports with Trail's own made-in-BC Generation at times when there was not enough capacity to meet demand in BC.

The alternatives were evaluated based on criteria that it must comply with the Clean Energy Act, it should reduce energy use and GHG emissions, it should increase profitability for Trail Operations, and it should be convenient to manage. The result of the evaluation showed that the Generation Swap had the greatest overall potential for Trail, despite the trade-off that that it would increase reportable GHG emissions. It is anticipated that the emissions could be offset by other social and environmental improvement projects that Trail could take on using the additional profit, an approach that this author thinks fits with Teck's Business and Sustainability Strategy. Based on rates for Load Curtailment in the industry, the Generation Swap could increase Trail's profit by \$9 million per year.

## References

- B.C. Ministry of Energy and Mines. (2010). *BILL 17 — 2010: Clean Energy Act*. Retrieved February 28, 2015, from [https://www.leg.bc.ca/39th2nd/1st\\_read/gov17-1.htm](https://www.leg.bc.ca/39th2nd/1st_read/gov17-1.htm)
- Barnes, A. (2008, November 20). *Teck Reduces Zinc Production in Response to Global Recession*. Retrieved June 6, 2015, from Rossland Telegraph: <http://rosslandtelegraph.com/node/1334#.VXOrhM9Vikp>
- BC Government. (n.d.). *The BC Energy Plan: A Vision for Clean Energy Leadership*. Retrieved June 6, 2015, from [http://www.energyplan.gov.bc.ca/PDF/BC\\_Energy\\_Plan.pdf](http://www.energyplan.gov.bc.ca/PDF/BC_Energy_Plan.pdf)
- BC Hydro. (2013a, November 15). *Chapter 2: Load-Resource Balance*. Retrieved February 22, 2015, from Integrated Resources Plan: [https://www.bchydro.com/energy-in-bc/meeting\\_demand\\_growth/irp/document\\_centre/reports/november-2013-irp.html](https://www.bchydro.com/energy-in-bc/meeting_demand_growth/irp/document_centre/reports/november-2013-irp.html)
- BC Hydro. (2013b, November 15). *Chapter 9: Recommended Actions*. Retrieved February 22, 2015, from Integrated Resources Plan: [https://www.bchydro.com/energy-in-bc/meeting\\_demand\\_growth/irp/document\\_centre/reports/november-2013-irp.html](https://www.bchydro.com/energy-in-bc/meeting_demand_growth/irp/document_centre/reports/november-2013-irp.html)
- BC Hydro. (2014, June 27). *Load Curtailment / Interruptible Rate*. Retrieved June 6, 2015, from Meeting Summary: <https://www.bchydro.com/content/dam/BCHydro/customer-portal/documents/corporate/regulatory-planning-documents/regulatory-matters/capacity-discussion-with-ampc-june-2014.pdf>
- BC Hydro. (2015a, May 1). *IPP Supply List – In Operation*. Retrieved June 6, 2015, from <https://www.bchydro.com/content/dam/BCHydro/customer-portal/documents/corporate/independent-power-producers-calls-for-power/independent-power-producers/ipp-supply-list-in-operation.pdf>
- BC Hydro. (2015b). *Why Site C: Cost Estimate*. Retrieved June 6, 2015, from <https://www.sitecproject.com/why-site-c/cost-estimate>
- Hilts, S. (2010, June). *Improvements to Riverbank below Teck*. Retrieved October 26, 2013, from Panoramio: Google Maps: [http://www.panoramio.com/photo\\_explorer#view=photo&position=1&with\\_photo\\_id=37339740&order=date\\_desc&user=2350328](http://www.panoramio.com/photo_explorer#view=photo&position=1&with_photo_id=37339740&order=date_desc&user=2350328)
- Kepner, C. H., & Tregoe, B. B. (1997). *The New Rational Manager*. Kepner Tregoe.

- Manitoba Hydro. (2015, January 23). *Appendix 6.11*. Retrieved March 6, 2015, from Report to the Public Utilities Board: Curtailable Rate Program: [http://www.hydro.mb.ca/regulatory\\_affairs/electric/gra\\_2014\\_2015/pdf/appendix\\_6\\_11.pdf](http://www.hydro.mb.ca/regulatory_affairs/electric/gra_2014_2015/pdf/appendix_6_11.pdf)
- Porter, M. E. (2008, January). The Five Competitive Forces That Shape Strategy. *Harvard Business Review*, pp. 78-93.
- Statistics Canada. (2011). *Households and the Environment: Energy Use*. Retrieved June 6, 2015, from <http://www.statcan.gc.ca/pub/11-526-s/2013002/tablesectlist-tableauxsect-eng.htm>
- Teck Metals Ltd. (2014, September 10). *Teck Trail Operations Announces Construction of New Facility to Reduce Dust and Improve Community Air Quality*. Retrieved June 6, 2015, from News Releases: <http://www.teck.com/Generic.aspx?PAGE=Teck+Site%2fMedia+Pages%2fMedia+Detail&releaseNumber=3&portalName=tc>
- Teck Metals Ltd. (2015, March 3). *Teck Trail Operations Begins Construction of Groundwater Treatment Plant*. Retrieved June 2015, 6, from News Releases: <http://www.teck.com/Generic.aspx?PAGE=Teck+Site%2fMedia+Pages%2fMedia+Detail&releaseNumber=5&portalName=tc>
- Teck Resources Ltd. (2009 , June 17). Teck Announces Proposed Sale of One-Third Interest in Waneta Dam. *Company News Release*. Vancouver, BC: Teck Resources Ltd.
- Teck Resources Ltd. (2014). *Teck 2013 Sustainability Report: Resourceful*. Vancouver: Teck Resources Ltd.
- Teck Resources Ltd. (2015, February 12). *2014 Fourth Quarter Results*. Retrieved June 2015, from News Release: [http://www.teck.com/res/tc/documents/\\_ces\\_portal\\_meta/downloads/investors/quarterly%20shareholder%20report/q4\\_2014\\_report\\_february\\_12.pdf](http://www.teck.com/res/tc/documents/_ces_portal_meta/downloads/investors/quarterly%20shareholder%20report/q4_2014_report_february_12.pdf)
- U.S. Energy Information Administration. (2013, December 12). *Table 8.9.B. Winter Net Internal Demand, Capacity Resources, and Capacity Margins by North American Electric Reliability Corporation Assessment Area, 2012 Actual, 2013-2017 Projected*. Retrieved February 28, 2015, from Demand, capacity resources, and capacity margins: <http://www.eia.gov/electricity/data.cfm#demand>
- Wikipedia. (2015a). *Revelstoke Dam*. Retrieved June 6, 2015, from Wikipedia, the free encyclopedia: [http://en.wikipedia.org/wiki/Revelstoke\\_Dam](http://en.wikipedia.org/wiki/Revelstoke_Dam)
- Wikipedia. (2015b). *VRIO*. Retrieved June 6, 2015, from <http://en.wikipedia.org/wiki/VRIO>

Wood Mackenzie. (2015, February 17). Top of the league - But why? A review of zinc smelter cost leagues. *Insight*. Wood Mackenzie Ltd.

## Appendix A.

### Hydroelectric Turbines on Raw Water Outflows

Trail Operations has a potential opportunity to improve energy efficiency by installing two hydroelectric turbines on its raw water outflows (Figure A.1). The project has the potential to

- recover 10 TJ/year in energy,
- save \$150,000/year in electricity costs, and
- help Teck achieve one of its sustainability goals to reduce energy consumption.

The electricity recovered would be enough to supply 270 households in British Columbia.

**Figure A.1: Raw Water Outfalls and Proposed Turbine Locations**



*Note.* Photo Credit: (Hilts, 2010)

The initial cost is estimated at \$1.5 million; however, hydroelectricity has the benefits of low maintenance costs and a long life of 30 years. This project also has a relatively low risk because it could broker existing technology from the micro hydroelectric industry.