

**THE USE OF TASKS AND EXAMPLES IN A HIGH
SCHOOL MATHEMATICS CLASSROOM: VARIANCE OF
PURPOSE AND DEPLOYMENT**

by

Daniel Kamin
B.A.Sc., University of Toronto, 1980
B.Ed., University of Alberta, 1988

THESIS
SUBMITTED IN PARTIAL FULFILLMENT OF
THE REQUIREMENTS FOR THE DEGREE OF
MASTER OF SCIENCE

In the
Faculty of Education

© Daniel Kamin 2010

SIMON FRASER UNIVERSITY

Summer 2010

All rights reserved. This work may not be
reproduced in whole or in part, by photocopy
or other means, without permission of the author.

APPROVAL

Name: Daniel Jay Kamin
Degree: Master of Science
Title of Thesis: The Use of Tasks and Examples in a High School Mathematics Classroom: Variance of Purpose and Deployment

Examining Committee:

Dr. Cécile Sabatier, Assistant Professor
Faculty of Education, SFU
Chair

Dr. Peter Liljedahl, Assistant Professor
Faculty of Education, SFU
Senior Supervisor

Dr. Nathalie Sinclair, Assistant Professor
Faculty of Education, SFU
Supervisor

Dr. Rina Zazkis, Professor
Faculty of Education, SFU
External Examiner

Date Defended/Approved: August 23, 2010



SIMON FRASER UNIVERSITY
LIBRARY

Declaration of Partial Copyright Licence

The author, whose copyright is declared on the title page of this work, has granted to Simon Fraser University the right to lend this thesis, project or extended essay to users of the Simon Fraser University Library, and to make partial or single copies only for such users or in response to a request from the library of any other university, or other educational institution, on its own behalf or for one of its users.

The author has further granted permission to Simon Fraser University to keep or make a digital copy for use in its circulating collection (currently available to the public at the "Institutional Repository" link of the SFU Library website <www.lib.sfu.ca> at: <<http://ir.lib.sfu.ca/handle/1892/112>>) and, without changing the content, to translate the thesis/project or extended essays, if technically possible, to any medium or format for the purpose of preservation of the digital work.

The author has further agreed that permission for multiple copying of this work for scholarly purposes may be granted by either the author or the Dean of Graduate Studies.

It is understood that copying or publication of this work for financial gain shall not be allowed without the author's written permission.

Permission for public performance, or limited permission for private scholarly use, of any multimedia materials forming part of this work, may have been granted by the author. This information may be found on the separately catalogued multimedia material and in the signed Partial Copyright Licence.

While licensing SFU to permit the above uses, the author retains copyright in the thesis, project or extended essays, including the right to change the work for subsequent purposes, including editing and publishing the work in whole or in part, and licensing other parties, as the author may desire.

The original Partial Copyright Licence attesting to these terms, and signed by this author, may be found in the original bound copy of this work, retained in the Simon Fraser University Archive.

Simon Fraser University Library
Burnaby, BC, Canada

STATEMENT OF ETHICS APPROVAL

The author, whose name appears on the title page of this work, has obtained, for the research described in this work, either:

(a) Human research ethics approval from the Simon Fraser University Office of Research Ethics,

or

(b) Advance approval of the animal care protocol from the University Animal Care Committee of Simon Fraser University;

or has conducted the research

(c) as a co-investigator, collaborator or research assistant in a research project approved in advance,

or

(d) as a member of a course approved in advance for minimal risk human research, by the Office of Research Ethics.

A copy of the approval letter has been filed at the Theses Office of the University Library at the time of submission of this thesis or project.

The original application for approval and letter of approval are filed with the relevant offices. Inquiries may be directed to those authorities.

Simon Fraser University Library
Simon Fraser University
Burnaby, BC, Canada

ABSTRACT

This is an action research study into the uses of tasks and examples in a senior high school mathematics classroom, in which the teacher is the researcher. Investigating a teaching style that seemed to be highly examination-oriented, the study focuses on purposes and intentions behind the uses and deployment of tasks and examples within a problem-solving framework. The investigation reveals expected as well as unexpected teaching strategies employed to facilitate and expedite student learning, including the use of deliberate overloading, creation of dissonance, partial understanding, and atypical sequencing and progression of curricular material. The primary result of the study is a breakdown and classification of examples and problems in terms of their contexts in classroom teaching and teacher intention.

For my wife, Lisa, and my sons, Joshua and Austin,
for your support, and for sustaining me in this endeavour.

This study is also dedicated to our twenty-year old family cat Remo, who did his best to keep me company while writing this, by sitting on all of the papers and drafts and on my lap. He passed away on the eve of its completion.

ACKNOWLEDGEMENTS

I would like to express my appreciation to Peter Liljedahl for the encouragement and insights he provided along the way, facilitating the completion of this work.

TABLE OF CONTENTS

Approval	ii
Abstract.....	iii
Acknowledgements	v
Table of Contents	vi
List of Figures.....	viii
List of Tables	ix
Chapter 1: INTRODUCTION.....	1
1. Teaching and Craft Knowledge.....	1
2. Standard Practice and Teaching-to-the-Exam.....	2
3. Tasks, Examples and Problems.....	6
Chapter 2: SURVEY OF EXISTING EDUCATIONAL RESEARCH	11
1. Craft and Pedagogical Content Knowledge	11
2. Pedagogical Roles of Tasks and Examples: Exemplification	14
3. Categorizations of Tasks, Examples and Problems	16
4. Problem Solving	22
Chapter 3: METHODOLOGY	27
1. Setting	27
2. Data Collection	28
3. The Categorization of Tasks and Examples	31
Chapter 4: TASKS AND EXAMPLES: CONTEXT	40
1. Standard.....	41
2. Overview	43
3. Warm-up.....	46
4. Introductory	48
5. Limiting.....	51
6. Contrasting	55
7. Consolidating	57
8. Extending	59
9. Cross or Multi-topic	62
10. Uncommon or Exceptional Case.....	64
Chapter 5: TASKS AND EXAMPLES: TEACHING INTENTION	67
1. Standard.....	69
2. To Level	70

3. To Create Cognitive Dissonance	74
4. To Stimulate Inquiry	79
5. To Address Common Errors and Difficulties	83
6. To Create Partial Understanding	86
7. Structured Variation	88
8. To Overload.....	90
9. To Prefamiliarize With Upcoming Topics	92
10. To Create a Platform for Future Scaffolding.....	93
11. Across The Grain	95
Chapter 6: CONCLUSIONS.....	101
1. Classification of Tasks and Examples.....	101
2. Breach of Classroom Norms and Didactical Contract:	105
3. Future Considerations	109
Appendix.....	112
TRANSCRIPT 1	112
TRANSCRIPT 2.....	113
TRANSCRIPT 3.....	114
TRANSCRIPT 4.....	116
TRANSCRIPT 5.....	117
TRANSCRIPT 6.....	119
TRANSCRIPT 7.....	121
Reference List.....	125

LIST OF FIGURES

Figure 1: The Categorization of Tasks and Examples	34
Figure 2: Angles in Standard Position	42
Figure 3: Partial Probability Tree Diagram	45
Figure 4: Flattened Cube.....	47
Figure 5: Graph of Sinusoidal Function	49
Figure 6: Maclaurin Series.....	65
Figure 7: Solving $\cos 3x = -1$	77
Figure 8: Graphical Approach for $y = \cos k\left(x + \frac{\pi}{8}\right)$	78
Figure 9: Pathway Problem	81
Figure 10 Pathway Problem Variation	82
Figure 11: Graphs of $y = \cos x$ and $y = \cos^2 x$	97

LIST OF TABLES

Table 1:	Special Angle Values for $\cos x$ and $\cos^2 x$	97
Table 2:	Classification of Examples and Tasks – Context and Intention	102

CHAPTER 1: INTRODUCTION

1. Teaching and Craft Knowledge

This study examines and attempts to explain the various means in which tasks and examples are used in teaching senior high school mathematics, unusual in that I am both the researcher and subject of the research. The reasons for undertaking this study into my own practice stem from a desire to analyze, understand and perhaps justify my particular brand of teaching. As teacher-researcher, taking on the analysis of my own teaching provided certain challenges. In their analysis of the TIMSS (The Third International Mathematics and Science Study) 1999 Video Study, Hiebert, Gallimore, Garnier, Bogard Givvin, Hollingsworth, Jacobs, Chui, Wearne, Smith, Kersting, Manaster, Tseng, Etterbeek, Manaster, Gonzales, and Stigler (2003) observe that everyday teaching routines and practices can become invisible and, “can appear as the natural way to do things rather than choices that can be re-examined” (p. 3). Such practices develop over time to become innate, ingrained and instinctive. Leinhardt (1990) refers to these practices as “craft knowledge” in teaching. She comments on the difficulties encountered by teachers “distilling” their own craft knowledge:

...it is also difficult to determine whether a teacher is in fact reporting the critical, crucial, analytic pieces of performance and knowledge base. This problem does not exist because teachers are somehow less able than others

to identify important features of their skilled performance, but because it is inherently problematic for anyone both to engage in an act skilfully and to accurately interpret it (p. 19).

Teachers are rarely called upon to articulate the motivations and reasons for their pedagogical choices and actions. In their study on mathematics teachers' choices of examples, Zodik and Zaslavsky (2009) note:

... all five teachers whom we observed claimed that they had never articulated how to select and generate examples – not throughout their years of pre-service and in-service education nor with colleagues in their school or other forms of professional communications. Moreover, they had never explicitly thought about these issues (p. 173).

Teachers do not find it a simple task to elucidate their teaching methods. Ayres, Sawyer, and Dinham (2004) note that teachers were observed using many more types of teaching strategies than they themselves seemed to be aware of.

2. Standard Practice and Teaching-to-the-Exam

The impetus for conducting this study can be traced back to two contributing factors. The first was my intention to justify a teaching-to-the-exam approach; a secondary factor was a desire to investigate certain pedagogical elements of my teaching that I felt were somewhat unusual when compared to what I consider to be standard practice. Standard practice among teachers of mathematics can be defined as the teaching methodology guided by and adhering to well-established classroom norms. In very general terms, this practice consists of providing information to students through the use of classroom notes and examples, and the subsequent assigning of sets of tasks which

echo the mathematical content presented. Standard types of examples and tasks, associated with typical mathematics teaching, as well as classroom norms (and contravention of these) will be discussed later in this study. Those aspects of my teaching practice which might be construed as unusual have evolved in an attempt to break through the rhythms of student engagement and behaviours in the mathematics classroom that have arisen as a result of standard practice and classroom norms.

There is a perception among educators that teaching-to-the-exam, also known as measurement driven instruction, is detrimental, a practice to be avoided. The most frequent complaints are that this practice leads to narrowing of the curriculum, rote learning, diminished broad-based learning, and insufficient preparation of students for anything other than the exams they were prepared for (Guskey, 2007; Koretz, 2002; Madaus, 1988; Popham, 2001, 2007; Volante, 2006). Schoenfeld (1988) discusses the teaching of routinized procedures at the expense of understanding. “There is concern about the damaging effects of exam-driven instruction and the unintended lessons about what constitute problem solving and mathematics that emerge in the course of standard test-oriented instruction” (Lave, Smith, and Butler, 1988, p. 61). This prevailing view, that test preparation and learning are somehow mutually exclusive, contradicts what I observed my students to be experiencing. This intended vindication of exam teaching was a starting point, but as a realistic description of what I was doing, was inadequate, and not quite correct. This study represents the work done in more accurately defining and analyzing my teaching beyond my overly simplistic initial assessment.

What is the job of the mathematics teacher? This is open to interpretation. According to Hiebert et al (2003), the goal of teaching is to facilitate learning. Bills,

Dreyfus, Mason, Tsamir, Watson, and Zaslavsky (2006) suggest that, "... the role of the teacher is to offer learning opportunities that involve a large number of 'useful examples' to address the diverse needs and characteristics of the learners" (p. 1-135). However, teachers are also charged with the delivery of curriculum, as outlined in government documents. This curriculum relies on a set of learning outcomes, providing a framework within which the teacher works to instil some level of mastery in his or her students. However, in those courses with heavily weighted final examinations, or those jurisdictions with comprehensive exit exams, it might be argued that it is the teacher's primary responsibility to prepare students for those exams. Examinations that have important consequences for students, such as promotion to higher grades or admission to post-secondary institutions, have been labelled as "high-stakes tests". Students are under pressure to perform on these assessments, and may question the purpose of teaching material that will not be on these exams. As well, whether we agree with the fairness or validity of examination scores as indicators of school quality, strength and health, those results are used to rank schools. Teacher effectiveness is also judged by the school's exam performance. These perceptions are important, as they can influence school and course enrolment, and other aspects of the reality of employment that may stem from these factors. Madaus (1988) pointed out that, in jurisdictions where important decisions are presumed to be based on test results, teachers will teach to the test.

The task of meeting the objectives of both exam preparation and curriculum learning outcomes is approached through giving students a steady diet of questions and problems to work on. Through the school year, my Grade 12 mathematics students are given somewhere in the order of 900 to 1000 questions to work on, most of which are

problems taken from previous examinations. In this way, the exam questions themselves became the main resource for delivery of the course. Ayres et al (2004) report similar practices among teachers of high-achieving students in senior high school courses with external high-stakes exams. Exam problems collected over several years provided a clear definition of the scope of the curriculum. As Madaus (1988) points out, “In every setting where a high-stakes test operates, a tradition of past tests develops, which eventually de facto defines the curriculum” (p. 39). Most useful were the limiting¹ and higher level types of problems, which were instrumental in delineating the upper range of the curriculum.

However, the view of my teaching as exam-driven was not consistent with the “ideal” senior mathematics lesson which I strove to implement, nor the classroom atmosphere that I attempted to generate. This “ideal” class is filled with student activity in practical application of course content; that is, problem-solving. More specifically, this consists of students working on batteries of problems in small informal groups, occasionally interspersed with teacher intervention and instruction in the form of worked examples. The reality of my Grade 12 mathematics classroom might approach the optimal condition described above. Regardless of classroom realities, this description does not seem reconcilable with an “exam teaching” approach. A conclusion resulting from these clashing approaches to teaching and learning is that perhaps both are occurring. A certainty is that the course is being taught primarily through the use of examples and tasks, many of which originated from previous examinations. In this sense, the class was being prepared for the external examination; while this was certainly

¹ “Limiting” is used to describe the most difficult or complex type of problem that students should be expected to do.

underway, the examples used also served two other important purposes: they were exemplary in setting out and delivering the curriculum and many of them, along with their extensions and variations, were invaluable in their utility for problem-solving.

Research Question

Following from the above, the research question addressed in this study was formulated: **What are the aspects of my teaching process/method which are responsible for successful student learning?** This rather broad question is resolved into a more specific one: How do I use tasks and examples in my lessons to achieve my teaching goals? This will be accomplished by tracing the “lives” of examples and tasks, starting with their conception in the lesson.

3. Tasks, Examples and Problems

Over time, certain terms have taken on various meanings that may not be clear to all parties involved in the educational process. Trends in educational thought expressed in the professional literature seem to have resulted in “taken as shared”² interpretations of certain terms. Clear definitions and descriptions are essential for correct and succinct

² “Taken as shared” is a phrase meaning a concept whose interpretation is agreed upon by a group or collection of individuals.

communication of ideas including those pedagogical actions and constructs which I am attempting to describe and explain in this report. I will speak later to the lack of language to describe some of the phenomena I identify in the uses of tasks and examples.

Examples

The use of examples is woven into the fabric of what mathematics teachers do to such an extent that it is difficult to step back and isolate what is meant by “an example”, although this may seem to be quite obvious. “The selection of examples is the art of teaching mathematics” (Leinhardt, Zaslavsky, and Stein, 1990, p. 52). According to Bills et al (2006), examples are, “anything used as raw material for generalising, including intuiting relationships and inductive reasoning; illustrating concepts and principles; indicating a larger class, motivating, exposing possible variation and change, etc., and practising technique” (p. 1-127). Zodik and Zaslavsky (2008) put forward this notion of what constitutes an example:

Theoretically, every mathematical object can be seen as an example, that is, as a particular case of a larger class. We take the stand that for a mathematical (or any) object to become an example of something, there should be some mental interaction between the person and the object that registers in the eyes of the person as an example of a larger class.” (p. 169)

An example is somewhat of a nebulous entity. It may consist of a simple expression, or comprise a complex multi-stage problem. The different meanings ascribed to mathematical examples arise from the different perspectives of mathematics teachers, researchers and educators of mathematics teachers. An example may exist as an isolated object, or be used to define, characterize or demonstrate a mathematical idea or concept (exemplification).

Thus, while many objects may be used as an example, it is clear from a pedagogical perspective some have more explanatory power than others, either because they highlight the special characteristic of the object or because they show how to build many other examples of the focal idea, concept, principle or procedure (Zaslavsky, 2010, p. 108).

An example of a trinomial that could be factored is $x^2 - 2x - 15$. An example of trinomial factoring would demonstrate the factoring. How this factoring comes about would be the basis for a “worked example”. Similarly, an example demonstrating the concept of logarithms could be $\log_5 \frac{1}{25}$. How such examples are utilized forms the basis of the work in this study. Examples which include their solutions, along with the necessary teaching and support required to ensure that they attain their intended purpose, form “worked examples”. Atkinson, Derry, Renkl, and Wortham (2000) provide this description for worked examples:

As instructional devices, they (worked examples) typically include a problem statement and a procedure for solving the problem; together, these are meant to show how other similar problems might be solved. In a sense, they provide an expert’s problem-solving model for the learner to study and emulate” (p. 181).

For the purposes of this study, references to the teaching use of examples will allude to a worked example.

Problems (and Problem-solving)

As Fan and Zhu (2007) report, there exist different understandings among researchers about what comprises a problem. They define a problem as a situation that requires a solution and/or decision, no matter whether the solution is readily available or not to the solvers. It is often taken for granted that examples are problems, and that worked-examples incorporate problem-solving. However, this need not be the case, and

these need not be implicit assumptions. “Indeed, problems and problem solving have had multiple and often contradictory meanings through the years...” (Schoenfeld, 1992, p. 10). “The term problem-solving has become a slogan encompassing different views of what education is, what schooling is, of what mathematics is, and of why we should teach mathematics in general and problem solving in particular” (Stanic and Kilpatrick, 1989, p. 1). The authors of the TIMSS 1999 Video Study defined problems as, “events that contained a statement asking for some unknown information that could be determined by applying a mathematical operation. Problems varied greatly in length and complexity, ranging from routine exercises to challenging problems” (Hiebert et al, 2003, p. 41). Problems might consist of exercises: “straight-forward problems, usually presented with little context, for which a solution procedure apparently has been demonstrated” (Hiebert et al, 2005, p. 117), and applications, which are, “problems that appeared to have some adjustment to a known procedure, however slight, or some analysis of how to use the procedure” (ibid, p. 117). An ambitious technical and process oriented definition of problem solving is provided by Lesh and Zawojewski (2007):

Thus, problem-solving is defined as the process of interpreting a situation mathematically, which usually involves several iterative cycles of expressing, testing and revising mathematical interpretations - and sorting out, integrating, modifying, revising and or refining clusters of mathematical concepts from various topics within and beyond mathematics (p. 782).

For the purposes of this study, a problem is a task or question whose solution requires more than simple inspection, perhaps multiple stages of working to find a solution. Some level of complexity is implied, requiring reasoning and/or heuristics. As with examples, the best problems, from a teaching perspective, exhibit exemplary attributes, which briefly means that such problems are pedagogically significant with

respect to the teaching objectives, while also providing an appropriate level of complexity and challenge.

Tasks

A task can be defined as any question, exercise or problem assigned to students. Stein, Grover, and Henningsen (1996) define a mathematical task as “a classroom activity, the purpose of which is to focus student’s attention on a particular mathematical idea” (p. 460). Christiansen and Walther (1986) differentiate between routine tasks (exercises) and problem-tasks (problems). In mathematics classes, tasks are typically associated with lists of exercises, often repetitive groups of similar questions. Tasks, as referred to in this study, are those problems and questions that are assigned to students to complete, and may be in-class or outside of class time. Assessment items, which include questions and problems used on quizzes and tests, may not be considered in the same vein as classroom tasks and assignments; nonetheless, they are important teaching devices insofar in their use as worked examples after students have attempted them.

CHAPTER 2: SURVEY OF EXISTING EDUCATIONAL RESEARCH

1. Craft and Pedagogical Content Knowledge

Shulman (1986) identified three categories of knowledge pertinent to transforming the knowledge of the teacher into the content of instruction. Subject matter content knowledge, the amount and organization of knowledge in the mind of the teacher; pedagogical content knowledge, the content knowledge that embodies the aspects of content most germane to its teachability; and curricular knowledge. Of most relevance to this study is teachers' pedagogical content knowledge:

Pedagogical content knowledge includes knowledge of how to represent ideas in order to make them comprehensible to the learner. It also includes knowledge of the difficulties that students are likely to encounter in learning a particular topic as well as strategies for overcoming those difficulties. It includes knowledge of the conceptual and procedural knowledge that students bring to the learning of a topic, the misconceptions they may have developed, and the stages of understanding that they are likely to pass through in moving from a state of having little understanding of the topic to mastery of it (Carpenter, 1988, p. 192).

Shulman adds, "Since there are no single most powerful forms of representation, the teacher must have at hand a veritable armamentarium of alternative forms of representation, some of which derive from research whereas others originate in the wisdom of practice" (Shulman, 1989, p. 9). In addition to knowledge of the potential of mathematical tasks and an awareness of "students' existing conceptions and prior

knowledge”, Krauss, Brunner, Kunter, Baumert, Blum, Neubrand, and Jordan (2008) identify a third aspect of mathematical pedagogical content knowledge, the knowledge of appropriate mathematics specific instructional methods. Ball (2000) comments on the link between content knowledge and pedagogical content knowledge:

Viewed from the perspective of practice and the actual work of teaching, at least two aspects seem central. First is the capacity to deconstruct one’s own knowledge in to a less polished and final form, where critical components are accessible and visible. This feature of teaching means that paradoxically, expert personal knowledge of subject matter is often ironically inadequate for teaching. Because teachers must be able to work with content for students in its growing unfinished state, they must be able to do something perverse: work backward from mature and compressed understanding of the content to unpack its constituent elements. Knowing for teaching requires a transcendence of the tacit understanding that characterizes and is sufficient for personal knowledge and performance (Ball, 2000, p. 245).

Zodik and Zaslavsky (2008) consider the connection between pedagogical content knowledge and teachers’ use of examples:

With respect to exemplification, the mathematical aspect of an example has to do with satisfying certain mathematical conditions depending on the concept or principle it is meant to illustrate. Knowledge of students learning includes a teacher’s understanding of how students come to know and how their existing knowledge affects their construction of new knowledge. It also relates the teacher’s sensitivity to students’ strengths and weaknesses, and with respect to examples – to teachers’ awareness of the consequences of students’ over-generalizing or under-generalizing from examples, and students’ possible tendency to notice irrelevant features of an example instead of attending to its critical features (p. 167).

The lack of common referents in terms of language to describe the pedagogical actions by classroom teachers is addressed by Staples and Truxaw (2007):

At the present time, the shared professional discourse of the mathematics education community lacks the capacity to describe the core of its work – mathematics pedagogy. To strengthen mathematics teaching and learning, we contend that it is critical to develop a shared language of mathematics pedagogy... This shared language may facilitate discussions of practice, support teacher learning, and afford conceptual tools that teachers can draw on as they organize mathematically rigorous lessons and reflect on their teaching (p. 206).

Bohicchio, Cole, Ostien, Rodrigues, Staples, Susla, and Truxaw (2009) identified high school mathematics teachers' pedagogical "moves", which "elicited, extended, or built on students' mathematical thinking or guided the lesson's mathematical trajectory". They attempted to create a shared language to describe these results. In their investigation into "mathematical-pedagogical" actions and behaviours of prospective teachers, Zazkis, Liljedahl, and Sinclair (2010) use the term "teaching moves" to characterize these behaviours and actions. In doing so, the authors comment, "Our naming of teaching moves helps in bringing them into being" (p. 35).

Earlier in this study, the idea of craft knowledge in teaching, and the difficulties teachers have in analyzing their practice were discussed. The ways in which pedagogical content knowledge is expressed into practice of classroom teaching from the perspective of teachers, especially at the senior high school level, is not well reported in the literature. Difficulties are compounded by the lack of appropriate language with which to describe these aspects of teaching, although progress is being made in this area. These challenges directly impact on the work done in this study, as will be shown in my analysis of task and example use.

2. Pedagogical Roles of Tasks and Examples: Exemplification

The use of examples is generally acknowledged to be an essential and ingrained aspect of most mathematics teaching (Atkinson et al, 2000; Bills et al, 2006; Carpenter, 1989; Mason, 2006; Stein et al, 1996; Zaslavsky, 2010; Zodik and Zaslavsky, 2008). “Examples are an integral part of mathematical thinking, learning and teaching, particularly with respect to conceptualization, generalization, abstraction, argumentation and analogical thinking” (Zodik and Zaslavsky, 2008, p. 165). When examples perform as such, they “exemplify”. This obvious purpose of an example, however, must be seen as such by the student. “Mathematical objects only become examples when they are perceived as ‘examples of something’: conjectures and concepts, application of techniques or methods, and higher order constructs such as types of proof, use of diagrams, particular notation or other support, and so on (Goldenberg and Mason, 2008, p. 184). “Exemplification is used to describe any situation in which something specific is being offered to represent a general class to which learners’ attention is to be drawn” (Bills et al, 2006. p. 1-127). Examples which best demonstrate these attributes have been termed “exemplary”, which Mason (2002, 2006) explains, is when learners can see through a few particulars to a generality:

What makes an example exemplary is seeing it as a particular case or instance of a more general class of objects; being aware of what can be varied and still it belongs to the class, and within what range of values can it be varied. The invariance is the ‘type’, concept or technique. Thus, exemplariness resides not in the example, but in how the example is perceived (Mason, 2006, p. 17).

Further, Mason identifies the following tactics for exposing “examplehood”, which he describes as, “promoting appreciation of generality inherent in concepts, properties and techniques” (ibid., p. 63):

- Another and another: a sequence of examples constructed by students to promote an awareness of variation;
- Dimensions of possible variation: describing and exploring the range of variable aspects of examples;
- Reversing: Exploration of similar tasks which produce the same answer;
- Characterising: Describing all possible objects having a specified property;
- With and across the grain: Attending to patterns (with the grain) and attending to the underlying structure expressing and interpreting the significance of the generalities (against the grain).
- Reveal and obscure: Constructing example(s) which reveal and then obscures a property;
- Particular to general: Using particulars to suggest generalization;
- General to particular: Using a general question to identify particulars.

Bills et al (2006) review the use of examples from historical, theoretical, teaching and learning perspectives. From the teaching perspective, they emphasize the complexity of example use, and discuss examples as fundamental tools for communication and instructional explanation. They describe two attributes of good examples: transparency, a measure of the relative ease with which the example draws attention to its exemplary features; and generalizability, reflecting the ability of the example to point to its arbitrary and changeable features. The mechanisms behind the use of examples, as shown above, are instrumental in understanding how examples are used. This addresses the research

question driving this study: determining the aspects of teaching process/method which are responsible for successful student learning.

3. Categorizations of Tasks, Examples and Problems

Various authors have created categorizations of examples from different perspectives. These include those based on a knowledge acquisition perspective; others reflect various characteristics of the tasks, examples and problems used, as well as their pedagogical aspects. In her epistemological treatise on the attainment of mathematical knowledge, Rissland (1978) examines three major categories of items comprising mathematical knowledge:

- results (traditional logical deductive elements of mathematics);
- examples (illustrative material);
- concepts (mathematical definitions and heuristic notions and advice)

“Thus, mathematical knowledge can be structured by three major types of item/relation pairs –example/constructional derivation, results/logical support, and concepts/pedagogical ordering – which establish three representation spaces for a mathematical theory: examples-space, results-space and concepts-space. She further defines epistemological classes of the “examples-space” as consisting of four types of examples:

- Start-up examples (motivation for and initiation into a topic);
- Reference examples (basic, widely applicable, standard cases);
- Model examples (paradigmatic, generic examples);
- Counterexamples (demonstrating that conjectures are false).

The mathematics portion of the TIMSS 1999 Video Study (Hiebert et al, 2003) included 638 eighth-grade lessons collected from seven participating countries. The authors found that significant portions of lessons were given over to solving mathematics problems. For all problems that were identified, three purposes were defined: review, introducing new content, and practicing new content. The authors also considered how problems were connected, distinguishing among four basic kinds of relationships occurring in lessons:

- Repetition: practicing procedures;
- Mathematically related: using solutions to a previous problem, extending a previous problem, highlighting some operations of a previous problem, or elaborating on a previous problem;
- Thematically related: associated with a preceding problem of similar topic or theme;
- Unrelated: using different operations, and not related mathematically or thematically to any of the previous problems in the lesson.

The authors also distinguished between applications and exercises. Exercises consisted of similar problems involving the use of taught procedures; applications required the use of learned procedures to solve problems presented in a different context. Shavelson, Webb, Stasz, and McArthur (1988) identified features characteristic of expert teaching of mathematical problem solving. Those that directly impact the use of tasks and examples include:

- activating of students' prior knowledge relevant to teaching a new concept;
- sequencing relevant prior knowledge from less relevant to more relevant;
- using multiple representations of concepts;
- coordinating and translating among alternative representations;

- providing informal proofs, alternative representations;
- providing detailed explanations and justifications of reasoning;
- linking concepts/operations to problem types.

Bills et al (2006) distinguish between examples of a concept and examples which consist of procedures. Those examples which demonstrate procedures are further classified into worked-out examples, “in which the procedure is performed by the teacher, text-book author or programmer, often with some sort of explanation or commentary” (p. 1-127), and exercises, which consist of tasks set out for learners to complete. They point out the lack of clarity among these distinctions, indicating that the representation of an object may also be construed as a procedure, and acknowledge the overlap between exercises and worked examples. Zaslavsky (2010) distinguishes among specific, semi-general and general examples, according to their “explanatory power”. She identifies the following cases of teacher’s use of examples: conveying generality and invariance, explaining and justifying notations and conventions, establishing the status of pupil’s conjectures and assertions, connecting mathematical concepts to real life experiences, and the challenge of constructing examples with given constraints. These cases underline her conclusions that, “Choosing instructional examples entails many complex and even competing considerations, some of which can be made in advance, and others that only come up during the actual teaching. Many considerations require sound curricular and mathematical knowledge” (p. 126). Zodik and Zaslavsky (2008) examined teachers choice and generation of examples in Grade 7, 8 and 9 mathematics classes. They identified the following types of considerations employed by teachers in generating/selecting examples:

- start with a simple or familiar case;
- attend to students' errors;
- draw attention to relevant features;
- convey generality by random choice;
- include uncommon cases;
- keep unnecessary work to a minimum.

Among their observations was that almost half of all the teacher-generated examples observed were spontaneously constructed.

In their study into the use of tasks used in Grade 6 to Grade 8 mathematics classes, Stein et al (1996) investigated the extent to which mathematical thinking and reasoning was occurring as a result of these tasks. Their coding decisions distinguished between "...tasks that engage students at a surface level and tasks that engage students at a deeper level by demanding interpretation, flexibility, the shepherding of resources, and the construction of meaning" (p. 459), and examined these tasks in terms of their task features and their cognitive demands. Of interest are the coding decisions they made for these tasks, which fall under four main categories: task description, task set up, task implementation, and factors associated with the decline or maintenance of high-level tasks:

Task description:

- percentage of class time devoted to the task;
- type of resources used;
- type of mathematical topic;
- context (real-world or abstract context);
- whether or not the task was set up as a collaborative venture among students.

Task set-up:

- number of possible solution strategies;
- number and type of potential representations that could be used to solve the problem;
- communication requirements of the task (the extent to which students were required to explain their reasoning and/or justify their answers);
- cognitive demands (memorization, the use of formulas, algorithms or procedures without connection to concepts, understanding, or meaning);
- cognitive activity (complex mathematical thinking, reasoning, making and testing conjectures).

Task implementation (noting changes from task set-up to implementation):

- change in number of solution strategies;
- change in number and kind of representations;
- change in communication requirements.

Atkinson et al (2000) call attention to the worked examples research, and discuss the implications of the findings on instructional design. They stress that learning from worked examples is of major importance during the initial stages of cognitive skills acquisition, including those required in other domains such as music and athletics. For worked examples to contribute to instructional effectiveness, they must be looked at in the context of the entire lesson (inter-example features) or how examples are designed, connected and presented (intra-example features). They note three “intra-example” (how such examples should be designed and constructed) features:

- integration of example parts (text and diagrams);
- use of multiple modalities (integrating aural and visual information);
- clarity of sub-goal structure (integrating steps and sub-goals).

The relationships among examples and how lessons should be designed, which they termed “inter-example” features are :

- multiple examples per problem type;
- multiple forms per problem type (effects of varying problem types within lessons);
- surface features that encourage a search for deep structure (variability in problem context);
- examples in proximity to matched problems (example-problem pairs).

How the above features of examples are best used to facilitate learning is explained as follows:

First, transfer is enhanced when there are at least two examples presented for each type of problem taught. Second, varying problem sub-types within an instructional sequence is beneficial, but only if that lesson is designed using worked examples or another format that minimized cognitive load. Third, lessons involving multiple problem types should be written so that each problem type is represented by examples with a finite set of different cover stories and that this same set of cover stories should be used across the various problem types. Finally, lessons that pair each worked example with a practice problem and intersperse examples throughout practice will produce better outcomes than lessons in which a blocked series of examples is followed by a blocked series of practice problems (p. 195).

Krainer (1993) attempts to bridge theory with practice in terms of the conflict between instructional efficiency and the need for students to be consumers as well as producers of knowledge. In order to be “powerful”, tasks should:

- be interconnected to other tasks (horizontal connections);
- facilitate the generation of further interesting questions (vertical connections);
- initiate active processes of concept formation accompanied by concept generating actions;
- encourage reflection leading to further questions from the learners and leading to new actions.

In most of the studies cited above, the analyses and categorizations of the classroom implementation of tasks, examples and problems do not sufficiently address level of complexity that will be demonstrated later in this study.

4. Problem Solving

Since every problem used in the classroom is also an example, and the majority of examples considered in this study are problems (as defined earlier), it is instructive to review contributions from research on the instructional use of problems and problem-solving. Lesh and Zawojewski (2007) note the shifts and “pendulum swings” that have occurred during over this time span, between basic skill- level instruction and curricular emphases on critical thinking and mathematical problem solving. They also report a growing recognition among mathematics educators that, “a serious mismatch exists (and is growing) between the low level skills emphasized in test-driven curriculum materials and the kind of understanding and abilities that are needed beyond school” (p. 764). Polya’s (1957) problem solving heuristics are credited with being highly influential in bringing problem-solving to the fore of school mathematics curricula over the last four decades (Lesh and Zawojewski, 2007; Schoenfeld, 1992; Stanic and Kilpatrick, 1988). However, Schoenfeld (1982) asserted that, “...Polya’s characterizations did not provide the amount of detail that would enable people who were not already familiar with the strategies to be able to implement them” (p. 53). Schoenfeld also discusses the

phenomenon of students purportedly solving problems, but in reality working with drill-and-practice exercises on simple versions of problem-solving strategies.

Stanic and Kilpatrick (1988) take a historical perspective to examine the role that the teaching of problem solving plays in school curriculum, describing three general themes that characterize this role. These include problem solving as context for achieving other purposes, problem solving as skill, and problem solving as art. As a “context” for achieving other goals, they identify the following:

- Justification: problems provide justification for the teaching of mathematics;
- Motivation: aim of gaining student interest;
- Recreation: to allow students to have some fun with the mathematics;
- Vehicle: vehicle through which new concept or skill might be taught;
- Practice: having the largest influence on the mathematics curriculum, practice to reinforce skills and concepts.

Problem solving may be considered as one of a number of skills constituting curriculum. Stanic and Kilpatrick distinguish between routine and non-routine problems, pointing out, unfortunately, that non-routine problem solving becomes an activity restricted to especially capable students rather than all students. Lastly, they consider problem solving as art, as emerging from the work of Polya. Their view is that problem solving as art is the most defensible, fair and promising, but most problematic theme because it is the most difficult to “operationalize” in textbooks and classrooms.

In their overview of past research into the teaching of mathematical problem solving, Lesh and Zawojewski (2007) identify major areas of research. Those appearing prior to 1990 include task variables and problem difficulty studies (focusing on features of the types of problems students were given), expert/novice problem solver studies, and

instruction in problem-solving strategies. They also identify three avenues of research on higher-order thinking in mathematical problem solving: metacognition, habits of mind, and beliefs and dispositions. They conclude the learning of mathematics should occur through problem-solving, and propose a shift from traditional views of problem solving to one that emphasizes, “synergistic relationships” between learning and problem solving. They suggest the adoption of a models-and-modeling approach, in which the learning of mathematics takes place thorough the use of mathematical modeling in problem-solving. This approach is contrasted with the traditional approach to problem-solving, which the authors view as a four-stage process:

1. Master pre-requisite ideas and skills;
2. Practice newly mastered skills;
3. Learn general content-independent problem-solving processes and heuristics;
4. Learn to use the preceding ideas, skill and heuristics in applied problems.

As discussed in Chapter 1, the line between what constitutes a problem and other types of classroom tasks is not clear. For example, the TIMSS 1999 Video Study simply treats all examples and tasks used as problems. In that study, such problem statements used in classrooms were classified by the mathematical processes implied, as either using procedures, stating concepts, or making connections. The authors described “making connections” as, “Problem statements that implied the problem would focus on constructing relationships among mathematical ideas, facts, or procedures. Often, the problem statement suggested that students would engage in special forms of mathematical reasoning such as conjecturing, generalizing, and verifying” (Hiebert et al, 2003, p. 98). This aligns more closely with the activity of “problem-solving”, as do problems that the authors classified

as “applications”, in which students are required to apply procedures learned in one context to address a problem presented in a different context. An important distinction emerging from the study, and a characteristic differentiating higher achieving countries from their counterparts, was in how “making connections” types of problems were implemented in the classroom. These problems either retained their intended characteristics or degenerated into more simple “using procedures” types of problems. This “routinization” of complex tasks is also reported by Stein et al (1996) in their study on task use. They noted that, frequently, teachers would do too much for the students, taking away students’ opportunities to discover and make progress on their own. High-level tasks often declined into less demanding activity due to student failure to engage in these activities, attributed to lack of interest, motivation or prior knowledge:

Although this factor spans a variety of reasons, the reasons all relate to the appropriateness of the task for a given group of students. The preponderance of this factor points to the importance of the teachers’ knowing their students well and making intelligent choices regarding the motivational appeal, appropriate difficulty level, as well as the degree of task explicitness needed to move their students into the right cognitive space so that they can actually make progress on the task (p. 480).

To maintain student engagement in “high level” tasks, Henningsen and Stein (1997) report five influential factors: the extent to which the task builds on students’ prior knowledge: scaffolding (simplifying the task while maintaining its complexity), appropriate amount of time provided, high level performance modelled by teachers or capable students, and sustained teacher pressure for explanation and meaning. Lesson design strategies employing worked examples to promote expert thinking and creative problem solving, in addition to procedures (Atkinson et al, 2000) are discussed earlier in this chapter.

Bills et al (2006) examine the impact that example use has on learner reasoning and problem-solving proficiency, referring to a continuum that runs from remembering suitable examples to analogical reasoning. The learner may apply known techniques from relevant worked-out examples. In contrast, to problem solve by modelling and using heuristics, knowledge of similar situations is required. “This mixture of logical-based reasoning (using deductive mechanisms) and example-based reasoning characterise mathematical competence at every level” (Bills et al, 1-142).

Research on problems and problem-solving confirms their pervasive presence in teaching philosophy and curriculum, although authentic problem-solving is not often realized. There is a tension between the teaching of mathematical basics and problem-solving. My approach corresponds with that of Lesh and Zawojewski (2007), in which learning should occur through problem-solving. However, as reported in several studies, these attempts often result in a reduction to the less desirable outcome of routinized exercises. Although not examining the impact of problem-solving per se, the choices made in this research and in my teaching in general are driven by the assumption that problem-solving is one of my essential purposes and goals.

CHAPTER 3: METHODOLOGY

1. Setting

School and Students

This research study was conducted at a secondary school in Vancouver, British Columbia over the course of 2008 and 2009. The school is an urban high school of approximately 1300 students from Grade 8 to Grade 12 situated in a relatively affluent section of Vancouver, British Columbia. The expectations of the adjacent community are high for students at this school to have a successful high school experience. Typically, this success is realized, with the vast majority of students graduating and moving on to local and Canadian universities and colleges. Therefore, a large constituency of the students are highly motivated in academic courses. However, this does not preclude a large number of students from experiencing difficulty in mathematics courses. Graduation requirements in British Columbia are fulfilled with a Grade 11 mathematics course; many students in the school (approximately 30%) choose to not go on to a Grade 12 math course. Students wishing to pursue studies in mathematics and science based post-secondary paths require the Grade 12 math course. Starting in 2008, formerly mandatory government exams³ became optional for students.

³ Final grade 12 government exams, optional except for English 12, make up 40% of a student's grade.

The Grade 12 course in which this study is carried out, Principles of Mathematics 12, evolved from its 1980's precursor, Algebra 12, through "Mathematics 12", to its current incarnation.⁴ There have been a number of curricular changes over time, but it remains essentially a pre-calculus course, with units on Transformations (of functions), Trigonometry, Logarithms, and Sequences and Series. The course also contains Combinatorics and Probability units. Students in these classes typically have a wide range of abilities, and enter with various levels of preparedness. Although most of the students in the Grade 12 math course are Grade 12 students, typically 17 years of age, an increasing number of students from lower grades are populating these classes. In recent years, students have been able to accelerate through high school academic courses by taking Grade 10 and higher academic courses during the summer, and distance education.

2. Data Collection

The most appropriate description of this study is action research. In my case, as teacher-researcher, the type of action research is referred to as participatory, or self-reflective research (Cresswell, 2008), in which the researcher retrospectively constructs an interpretation of the action. The hallmarks of action research apply here: data collection through experiencing (observation, fieldnotes) and examining (using and making records), documents, journals, videotapes and fieldnotes. In the sense that the direction of the study underwent some refocusing during data analysis, the research

⁴ A new set of courses for grade 12 mathematics, Pre-Calculus 12 and Foundations of Mathematics 12 is scheduled for implementation in 2012.

method also contains some aspects of grounded theory design. Charmaz (2000) describes this method as consisting of systematic inductive guidelines for collecting and analyzing data to build theoretical frameworks that explain the collected data. As self-reflective action research, the analysis of the data required detachment, objectivity and chronological accuracy. Although I strived to achieve these, I cannot guarantee them. The separation of a priori perceptions, assumptions and awareness from those aspects revealed through analysis and reflection, defined one of the essential difficulties with this study. “Since we always create our personal narrative from a situated location, trying to make our present, imagined future, and remembered past cohere, there’s no such thing as orthodox reliability in autoethnographic research” (Ellis and Bochner, 1996, p. 751).

Data collection began with the documentation of examples and problems used in my Grade 12 mathematics classes during the 2008-2009 school year. At an early point in the study, in order to uncover the aspects of my teaching most responsible for student learning, I also considered methods of compiling student perceptions of understanding and learning based on what was meaningful to them. However, as teachers find it difficult to elucidate the nature of their practice, it is at least as difficult, if not more so, for students to identify the mechanisms behind their learning. Overall, student responses to these kinds of questions were not, in general, very helpful. For example, an initial stage of this study attempted to identify aspects of examples which students thought were instrumental to their understanding and learning. In retrospect, asking students to probe their awareness of metacognitive processes was unlikely to produce meaningful results without significant training. Not surprisingly, that exercise did not provide information that was directly useful. Leaving the complexities of student learning for subsequent

research, I targeted task and example usage from the teacher's perspective. In order to determine how and why these tasks and examples were being used required tools - ways in which to facilitate an analysis. What was necessary was a method by which I could penetrate the body of "craft knowledge". The challenge involved the determination of a means to make structural sense out of the collective of strategies which combine to form my technique. As described in Chapter 1, the complexity of craft knowledge is difficult to deconstruct. Parallel or analogous studies in the research appeared to be quite rare, as noted in the previous chapter.

As I have indicated, initial attempts to acquire student learning data were abandoned. The analysis of records, plans, journaling and self-reflection of my lessons form the basis of this research. To ascertain whether there were additional qualities in the actions of teaching that transcended identification through the above written and "static" records, lesson video-recording was undertaken. "By using video it is possible to capture the simultaneous presentation of curriculum content and execution of teaching practices. It can be difficult for teachers to remember classroom events and interactions that happen quickly, perhaps even outside of their conscious awareness" (Hiebert et al, 2003, p. 5). There was no attempt to record any particular type of lesson or make those that were recorded particularly better examples of my practice. The recording was completed over a period of three weeks, covering a more or less random string of lessons across two different Grade 12 mathematics classes. One of these was a regular "math 12" class, and the other an "enriched" math 12 group⁵. In all, just over 500 minutes (8.5 hours) of class time over 8 lessons was recorded. The video recordings were reviewed, and transcripts

⁵ This enriched group was comprised mostly of Grade 11 students. They typically receive the same instruction, perhaps sooner and at a slightly accelerated pace.

were made of selected portions of lessons which were relevant to the teaching use of examples and tasks were made. Seven of these lesson episode transcripts, selected as representative samples or subsequently referred to in this report, may be found in the Appendix.

3. The Categorization of Tasks and Examples

The accumulated data on task and example use in my grade 12 mathematics classes consisted of documentation taken from lesson plans, journals, as well as my lesson reflections, assessment items and the video record. Informed by a-priori assumptions and ideas from my teaching practice, I attempted to trace the “lives” of these examples, tasks and problems (for simplicity, in the subsequent discussion, I will use the term example to include tasks and problems). Most of the examples in my lessons are used for a variety of reasons, and often with one or more ulterior teaching motives. As well, changes to the initial reasons for using tasks and examples during their deployment are not unusual. Not only can examples take on different attributes for teaching purposes, but they may be perceived in different ways from the student perspective. It is therefore unlikely that any example represents or accomplishes a single purpose. In order to determine these purposes, and clearly and fully explain example use and deployment, four types or levels of description emerged. At the most basic level, the term “Origin” is used to indicate how an example emerged, or came to be, in a lesson. Once a task or example is brought to the lesson, or is at some stage of implementation, it became necessary to look at the

teaching means through which it is delivered, or communicated to the class. “Delivery”, the second major category, represents the manner in which the example is communicated to the class. These first two categories of example description, Origin and Delivery, are primarily mechanical aspects of lesson planning and represent superficial aspects of the teaching process. As such, they were largely understood, if not obvious, prior to this study. The more difficult questions to answer were how and why these examples were being used. What were the teaching goals I intended to accomplish through their use? In the course of considering these questions, further organization emerged, resolving into two additional categories:

- Context: When and how examples/tasks are used;
- Intention (or intent): Why they are used?

It is possible that these two categories may have been melded into a single one, as there are a number of connections and similarities among the many subdivisions of “Context” and “Intent”, as will be demonstrated in the following two chapters. However, there are important distinctions between the two categories, which not only justify their formulation, but explain the order in which they are presented in this report. “Context” of example use embodies aspects of the teaching process that may be discerned by an outside observer. These “Contexts” correspond to some of the existing categorizations that have appeared in previous research, outlined in Chapter 2. Teaching “Intents” are subtly different in that they represent the least obvious, but more complex reasons for using examples. Through the various teaching “intents” of example use, the most idiosyncratic and perhaps controversial aspects of my teaching can be addressed.

The creation of this particular classification system is specific to the manner in which I have interpreted my own teaching. It is clear that other arrangements and interpretations are possible. However, this layout is one which seems to logically represent the aspects that emerged from this study. Further, the progression through Origin-Delivery-Context-Intention is one that moves from simple and obvious features to those that are more complex and difficult to identify and explain. The general organization of the classifications, under the broad categories of Origin, Delivery, Context and Intention, are laid out in Figure 1. The subdivisions in each category are shown below. The “Origin” and “Delivery” subdivisions are self-explanatory; the subdivisions of the “Context” and “Intent” categories, a much more important part of this report, are more fully explained with illustrative examples and definitions in Chapters 4 and 5.

Origin

There are five general modes of conception for example use in the lesson under this category:

- Planned
- Spontaneous
- Random
- Assessment (questions/problems on quizzes, tests or examinations)
- Student request (or resulting from student queries)

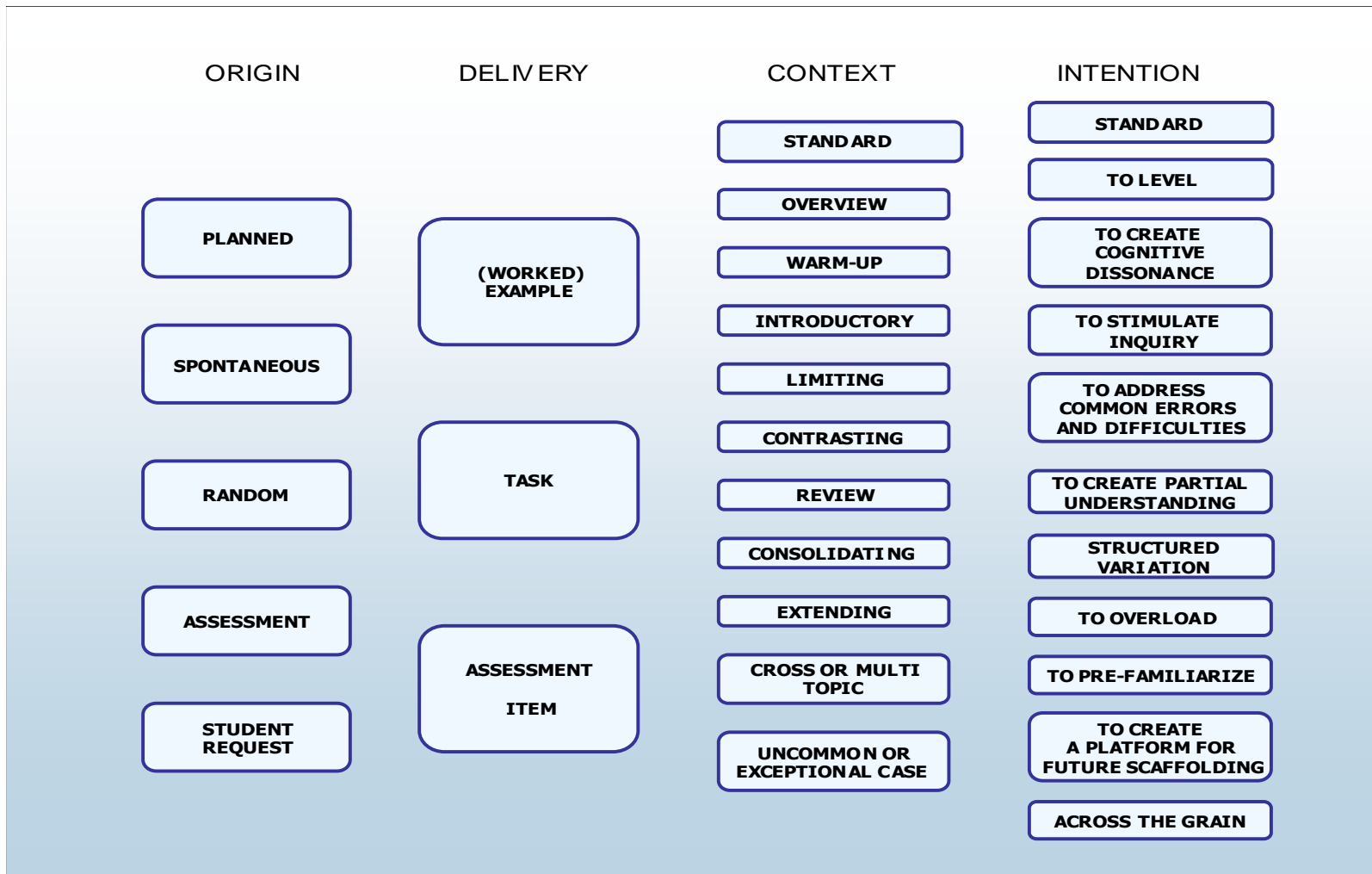

Figure 1: The Categorization of Tasks and Examples

Delivery

- Worked example
- Task
- Assessment item

Worked examples and tasks were defined in Chapter 1. Assessment items are also tasks, although delivered in a more formal setting, on test and exams.

Context

The different “Contexts”, or ways in which the examples were being used, were developed by considering the inherent qualities of the example and its chronological placement in the lesson, curricular unit, term, school year, etc. The language necessary to describe these was reasonably accessible. The different contexts arrived at were:

- Standard
- Overview
- Warm-Up
- Introductory
- Limiting
- Contrasting
- Review
- Consolidating
- Extending
- Cross or Multi-Topic
- Uncommon or Exceptional Case

Intent

In the final category of task and example description, teaching “intent”, pedagogical intention and teaching strategies are not apparent in and of the examples themselves, nor are they readily discernable from studying records of teaching. In fact, they represent my attempts to isolate, identify and give a name to the various features and attributes that define my teaching methods. These “moves” are related to those “mathematical-pedagogical actions” discussed by Zazkis et al (2010) and Boichichio et al (2009). Arriving at appropriate nomenclature for these proved difficult. Coding and categorization structures used in related studies, reported in Chapter 2, provided negligible guidance. Appropriate descriptors for some of the intentions I report do not seem to be present in the literature, or at least not in the necessary context. The following represent, as reasonably descriptive as possible, the teaching intentions resulting from my analysis:

- Standard
- To Level
- To Create Cognitive Dissonance
- To Stimulate Inquiry
- To Create Partial Understanding
- To Point Out Common Errors and Difficulties
- Structured Variation
- To Overload
- To Pre-Familiarize with Upcoming Topics
- To Create a Platform for Future Scaffolding
- Across The Grain

The following example (see Transcript 7, Appendix) is considered through the lens of the classification system outlined above:

Example 1.

Given the graph of $f(x) = \sin x$, sketch the graph of its reciprocal.

This example was used to introduce reciprocal trigonometric functions. I sought to employ a graphical approach to allow students to view this perspective much earlier than I usually do in this area, hoping that this atypical sequence would address a characteristic student weakness in understanding reciprocal trigonometric functions and expressions. Chronologically, it directly followed the graphing of basic trigonometric functions (see example 38). These students had already learned transformations of functions in an earlier curricular unit, and from this were familiar with the sketching of reciprocals of general functions. This included asymptotic behaviour, invariant points and other features of such graphs. The important aspects considered and points made during the flow of this example are:

- review of characteristics of the function $y = \sin \theta$, including a clarification of the meaning of the horizontal axis (representing an angle);
- emphasis that the function's domain consists of all real numbers;
- construction of the sine graph is facilitated by cutting the period in half and then half again;
- continuous emphasis on radian-degree conversion;
- characteristics of the reciprocal and its construction;
- using special angles: $\sin \frac{\pi}{4} = \frac{1}{\sqrt{2}}$;

- naming this function cosecant, $\csc 30^\circ = \frac{1}{\left(\frac{1}{2}\right)}$;
- domain and range of $y = \csc \theta$ (solutions over all real numbers).

As indicated above, passing through origin, delivery, context and intention, the classification organization proceeds from simple to more complex pedagogical concept. This example had its conception, or “origin”, in planning. The “delivery” was in the form of a “worked example”. The context is primarily introductory, with some elements of review and consolidation. The primary teaching “intention” for using this example in this way was to “address common errors and difficulties”. As indicated above, this relates partly to student difficulties with reciprocal functions in general, but more so with the problems they have working with expressions and equations involving reciprocal trigonometric functions. This atypical approach, presenting the graphical definition of cosecant first, could also be considered as a form of “working across the grain”⁶. Other intentions are manifested through this example, such as levelling (but not overly distinct from the contexts of review and consolidation), during the repetition of the construction of the sine graph. In the discussion on the domain of the cosecant function, there is an attempt to “prefamiliarize” with solutions over all real numbers, which is an aspect of the upcoming work on solving trigonometric equations. Certainly multi-faceted, the teaching intentions drive the mobilization of this example.

The above description provides a sense of how and why that example was used in the classroom. The features identified do not entirely capture the essence of the actual

⁶ “Across the grain” is a way in which a concept can be presented from a different point of view or in a different way. This is explained in Chapter 5.

deployment of the example, but rather provide as accurately as possible, given the available means, a deconstructed representation of what transpired. As emphasized, earlier in this study, there are challenges in articulating these motivations and reasons, and there are difficulties in explaining how craft knowledge is turned into instructional content. The last two categories in the classification system I have constructed, context and intention, are the most important as well as the most complex. Context is considered in the next chapter. “Intention,” comprising the most complicated set of ideas in this analysis, is presented in detail in Chapter 5.

CHAPTER 4: TASKS AND EXAMPLES: CONTEXT

“Context” is the first of two major organizers which I analyzed in depth. It consists of a set of descriptors which depict when (the chronological placement in a curricular unit) and how examples were used in my lessons. These attributes are reasonably self-evident, yet an example or task may manifest itself in several possible contexts. As will be demonstrated, context is typically a function of structural or chronological development in a lesson or over a number of lessons. The following contexts for tasks and examples are those that I have identified in my teaching:

- Standard
- Overview
- Warm-up
- Introductory
- Limiting
- Contrasting
- Review
- Consolidating
- Extending
- Cross or Multi-Topic
- Uncommon or Exceptional Case

These *contexts* are generally predetermined in planning. This does not preclude the necessity of having a number of examples ready, or spontaneously producing appropriate

examples, for the various eventualities that arise in classroom teaching. Whether the product of conscious thought, planning, improvised or spontaneous “in the moment” teaching, actual examples are used to illustrate each of the contexts.

1. Standard

There are many reasons for and modes of deploying specific examples and tasks. Among the multitude of reasons for the teaching use of these, there remain those examples which are used simply for typical and basic teaching purposes, as in illustrating concepts, simple exposition, and exemplification. Rissland (1978) referred to these as “reference examples,” in their use as basic, widely applicable, standard cases. For the purposes of this study, the “standard” context is included to point out that examples may be used in straight-forward and simple ways, in contrast with some of the other strategies that emerge later in this chapter. Another way to explain this is that such examples do not seem to fall under any other type of contextual categorization. The following examples are such cases:

Example 2.

$y = f(x)$ is transformed to $y = f(2x + 4)$.

This transformation is used in two ways. It either requires a graphical transformation of a generic function $y = f(x)$, or the statement of the transformation involved. When $2x + 4$ is factored to $2(x + 2)$, and $f(2x + 4)$ becomes $f(2(x + 2))$, it is clear that the function is horizontally compressed by a factor of 2 with respect to its distance from the y-axis, and then translated 2 units left. Students must already know how to use these facts.

Example 3.

The terminal arm of an angle θ in standard position passes through the point $(-3, 8)$. Determine $\sin \theta$, $\cos \theta$, $\tan \theta$ and θ .

The selection of a quadrant II angle allows an exploration of aspects of the trigonometric ratios and standard position angles. A diagram, though not absolutely necessary, is recommended (Figure 2). The visual aspect of many problems is an ongoing theme that will be addressed later in this report.

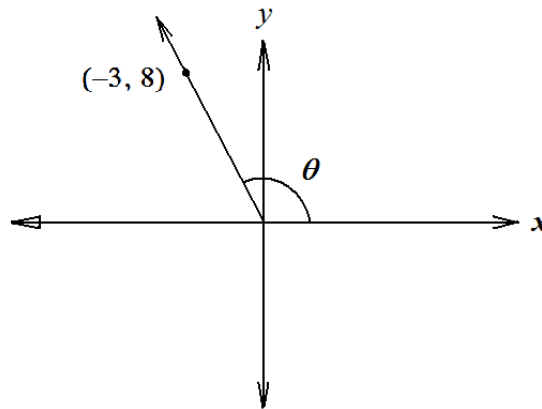

Figure 2: Angles in Standard Position

- The tangent of the angle θ is determined as $\frac{y}{x} = \frac{8}{-3}$
- $\sin \theta = \frac{8}{\sqrt{73}}$ and $\cos \theta = \frac{-3}{\sqrt{73}}$
- Now the determination of the angle θ . Any of the three above ratios can be used to obtain the angle, and it is necessary for the students to understand this. First, an estimate of the angle should place it at something in the order of 2 radians due to its placement in the second quadrant. This should be sufficient to alert students to problems with their answer.
- Using the inverse sine of $\frac{8}{\sqrt{73}}$ yields 1.212 radians. This is also the reference angle, which be subtracted from π to give the correct θ , 1.930 radians;

- Using the inverse cosine of $\frac{-3}{\sqrt{73}}$ gives us 1.930 directly; At this point, it is necessary to clarify the types of answers calculators provide when inverse trigonometric functions are used, and how these answers should be used.
- Using the inverse tangent of $\frac{8}{-3}$ gives us -1.212 radians, to which the addition of π will yield the correct quadrant II angle.

The two problems used above to demonstrate “standard” examples may not appear as such to students, especially those experiencing difficulty. The video evidence indicates that virtually all of the teaching analyzed attempts to simultaneously address different student skill and ability levels. It is therefore unlikely that any example represents or accomplishes a single purpose. However, the examples chosen to illustrate the different contexts explained below are specifically chosen to highlight those particular contexts. This will be true for the examples used for illustrative purposes in Chapter 5 as well, where “intent” is discussed.

2. Overview

Overview examples are problems which demonstrate some of the major points that constitute a curricular unit, typify its content, condense the material, and/or briefly demonstrate the progression through the unit and its overarching goal(s). In certain curricular units (or other natural division of the course content) that do not require a gradual build-up of competencies, such an example can provide an effective launch into the coursework. Units that particularly lend themselves to this approach are

Combinatorics and Probability. Outlining the learning outcomes or goals is beneficial, as knowledge of where the instruction is heading can provide motivation, raise interest, and stimulate inquiry. On the other hand, student confusion and distress may result if the example seems overly complex. It is likely that both benefit and detriment will occur simultaneously in a class, so care is necessary to ensure an overall positive result.

Example 4.

Determine the probability of winning the 6-49 lottery⁷.

- Allows a discussion of theoretical probability, the number of successful outcomes divided by total possible outcomes, and what we might glean from such information.
- employs previously learned combinatorics concepts to determine the number of ways 6 different objects can be selected from 49, in which the order does not matter: ${}_{49}C_6$, or 13 983 816, and showing that the probability of selecting the 6 winning numbers is $\frac{{}_6C_6}{{}_{49}C_6}$
- Since winning (to a lesser extent) also includes 3, 4 or 5 “correct” numbers, the example is extended to selecting, for example, 5 correct numbers and 1 incorrect number: This calculation incorporates the Fundamental Counting Principle of the product of choices: $\frac{({}_6C_5)({}_{43}C_1)}{{}_{49}C_6}$

The previous example and the next are both used to overview the probability unit. Each presents slightly different aspects of the upcoming material.

Example 5.

There is a 40% chance of rain on each of the next five days. What is the probability that it will rain on 3 of those days?

⁷ This lottery involves the selection of 6 numbers from 1 to 49, and having these six numbers match the six numbers drawn.

- We begin to construct a probability tree (Figure 3), which we could continue to show all 32 outcomes, but indicate the impracticality of doing so.
- The artificiality of using a fixed probability (independence) for these kind of events is discussed.
- The incomplete probability tree can be used to identify patterns or some way to determine the number of branches in which there are 3 days of rain and 2 days of no rain. One way is to look for the number of unique permutations of RRRNN.

This is a known problem from the combinatorics unit, $\frac{5!}{3!2!} = 10$.

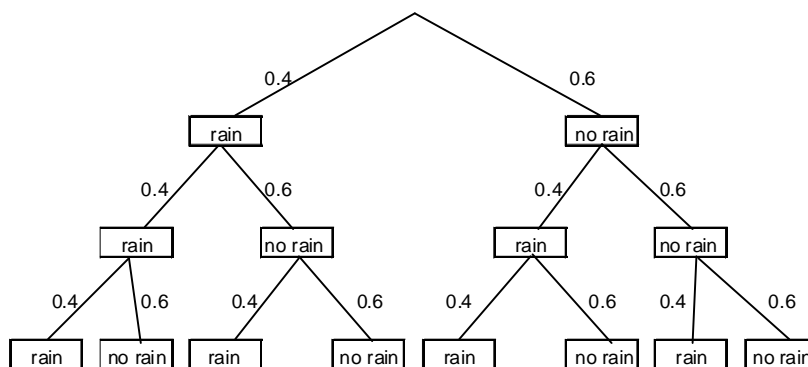

Figure 3: Partial Probability Tree Diagram

- Every branch that has 3 successes and 2 failures will have the same probability, $(0.4)^3 (0.6)^2$, and there are 10 such branches. The answer will be $10(0.4)^3(0.6)^2 = 0.2304$
- What of other results? Looking at 0, 1, 2, 3, 4, or 5 successes leads to the generic binomial probability equation for n trials, probability of success p , with x successes: $P(x) = {}_n C_x (p)^x (q)^{n-x}$

This example allowed me to go through many elements of the probability unit as well as providing an opportunity to give some of its “flavour”. Such examples, having the potential to lead to productive and perhaps essential discussion, provide excellent means for overview.

3. Warm-up

A warm-up by its own definition is a start-up task in the form of a student activity, used to bring students to a state of readiness, to focus energy, and allow students to be more receptive to upcoming work, to which it may or may not have a direct connection. If not connected to the curricular material at hand, it usually has some purpose, which might include reasoning, problem solving, mental math, etc. My interpretation of such an activity is that it requires a problem of sufficient complexity to generate a problem-solving atmosphere rather than simple review exercises. These kinds of activities are usually presented at the beginning of a lesson, but they may also be used at the beginning of curricular units, school terms, or at the beginning of the school year. Occasionally, an interesting or unusual problem is used as a warm-up; otherwise, the problem incorporates some review or practice of basics. Considering time constraints, warming-up is often incorporated into “introductory” examples. I tend to bypass warm-up tasks in general, but they do emerge from time to time. The following task was used as such. Although not directly related to curriculum, it draws from several useful areas.

Example 6.

An astronaut is attached to a space station which is in the shape of a cube with sides 100 m long. The astronaut’s cable is also 100 m long. What per cent of the surface area of the cube can the astronaut access if:

- a) the cable is attached to a corner of the cube?
- b) the cable is attached to the centre of one face of the cube?⁸

⁸ Adapted from Canadian Invitational Mathematics Competition, 1989, Waterloo Mathematics Foundation

As a warm-up task, the “space station question” provides a challenging problem in geometry and trigonometry.

- In order to proceed, it is useful to reduce the problem to a two-dimensional format. In Figure 4 below, a scale diagram of the flattened cube is drawn.
- For part b), a circle drawn with radius 100 metres is drawn with its centre in the centre of a cube face.
- The required area is visualized. A strategy for calculating it is required. One approach uses special angle relationships to find the area that must be subtracted from the 100 metre radius circle, or to determine the component areas that make up the total.

The factors making this and other such problems successful as warm-ups are their accessibility and interest level. Accessibility is a function of student ability, which

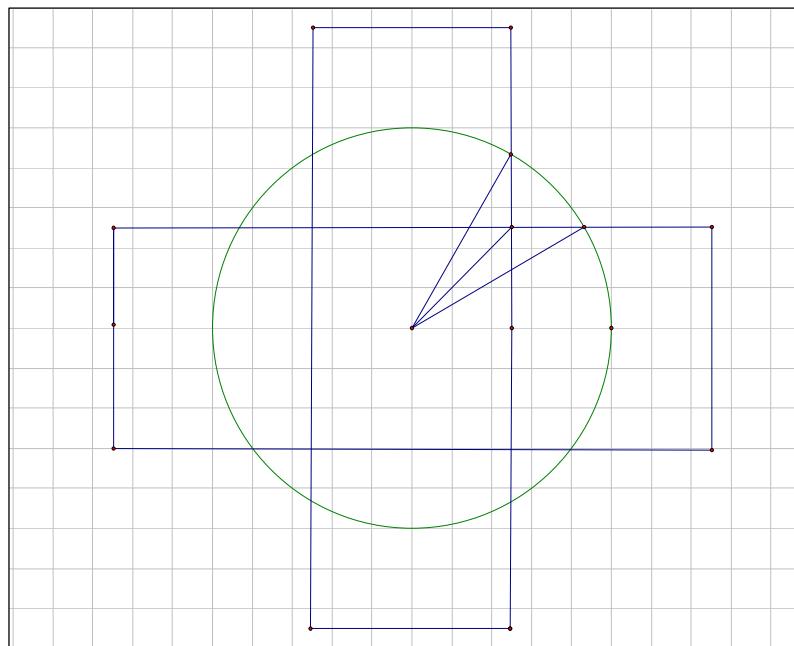

Figure 4: Flattened Cube

declines as the complexity of the problems increase. Unfortunately, the typical senior mathematics student is not engaged by such problems. As a result, many such interesting problems are abandoned, and often fall under the purview of the enriched classes only.

Another type of warm-up example is a special or interesting case pertaining to the current work, as shown in the following example:

Example 7.

7 people sit around a table. How many different seating orders are possible?

The question really is, what is the difference between this problem and the number of different seating orders for 7 people in a row (which students easily answer, $7!$, or 5040)?

It is best if students conclude on their own that there is no particular starting point on a round table, and realize that there are 7 times less, or $6!$ permutations.

4. Introductory

Introductory examples and tasks are used at the beginning of a course, unit, or other curricular content division, to help set the stage for subsequent development.

Rissland (1976) refers to these as “start-up” examples (see Chapter 2). Leinhardt et al (1996) suggest that, “the object is to craft the introduction, and later sequencing, in ways that enhance the early understanding...” (p. 47). Introduction differs subtly from overview, as it is concerned with entry only, and not a quick tour of the whole unit. The types of examples used to introduce a topic or unit range from a conventional simple type, which ease into the material gently, to the use of a limiting example. In any case, introductory examples tie previous work to up and coming work. An underlying use of problems to introduce topics is a subtle message to students that problem-solving is an embedded aspect of our course. This is most clearly illustrated by the use of a limiting problem, which also has the purpose of generating student interest. The following

introductory examples contain review, some characteristics of entire topic overview, and some “new” instructional aspects.

Example 8.

Find all intersections of the graphs of the functions $y = x^2$ and $y = 2^x$.

Graphing these functions should be review; in any case, both have been reviewed immediately prior to this. Two of three intersections, (2, 4) and (4, 16), are found by inspection. The remaining intersection cannot be found by these means, providing an opportunity to introduce various utilities of the graphing calculator. The next example was used to introduce the transformations of graphs of trigonometric functions:

Example 9.

Determine the equation of the (sinusoidal) function shown:

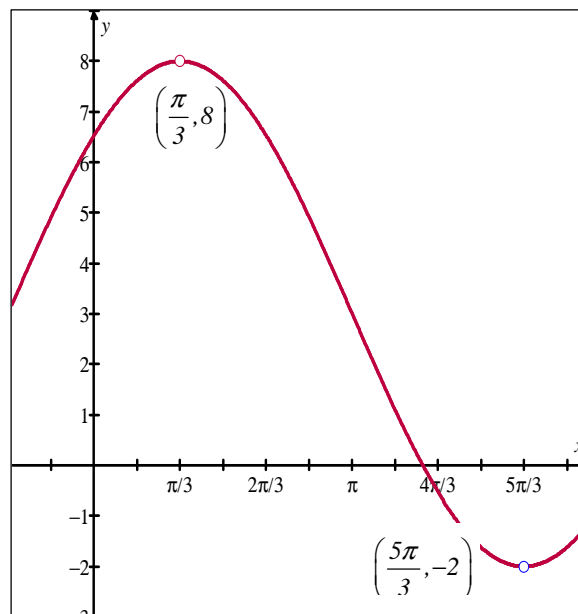

Figure 5: Graph of Sinusoidal Function

The transcript of the deployment of this example can be found in the Appendix, Transcript 3. Bypassing a generic and gradual introduction, this is an aggressive move forward. It should be noted, however, that there is really only one “new” aspect to this problem, as these students already have learned how to transform functions graphically and algebraically. They are also familiar with the properties of the graphs of sine, cosine and tangent, but have not dealt with transformations of periodic functions yet.

- The transformation of $y = f(x)$ to $y = af(k(x - p)) + q$ has been studied; Now we will extend these ideas slightly to the transformation of $f(x) = \cos x$ to $f(x) = a \cos(k(x - p)) + q$.
- The key idea is the *starting point*, which is tied to the choice of sinusoidal function. If we use (+) cosine, the starting point would be $x = \frac{\pi}{3} = p$.
- The central (horizontal) axis is midway between the maximum and minimum (vertical) points of the function: $\frac{8 + (-2)}{2} = 3 = q$; the amplitude is half of the range of the function, or the distance from the central axis to the maximum or minimum point, so $a = 5$.
- The final part is the determination of k , for which we use $\text{period} = \frac{2\pi}{k}$, or $k = \frac{2\pi}{\text{period}}$. The horizontal distance from a maximum point to the adjacent minimum is one half of the period. The period is $2\left(\frac{5\pi}{3} - \frac{\pi}{3}\right) = \frac{8\pi}{3} \therefore k = \frac{3}{4}$.
- The function is $f(x) = 5 \cos\left[\frac{3}{4}\left(x - \frac{\pi}{3}\right)\right] + 3$

Example 10.

Nine horses are in a race. How many different ways can they finish if two horses are tied?

There are several related purposes to using this example to introduce combinatorics, but primarily to instill the reasoning aspect necessary to address such problems. The problems also demand that attention paid to vocabulary and wording is crucial.

- To visualize the problem, the creation of a diagram or graphic may assist in pointing out the direction needed. In this case, assigning a letter to each horse, A, B, C, D, E, F, G, H, and I, is a simple way to proceed
- The problem indicates that two horses are tied, and does not specifically place them in the finishing “order”. Then, how many different pairs are possible, and does the order of the horses in the pair matter? Thus we introduce clearly the aspect of order.
- The tools provided in this unit on combinatorics provide exactly the means to determine the number of different pairs which can be selected from 9 “objects”: 9C_2 .
- Our diagram should help in visualizing that there are 8 finishing places. One of the early concepts we look at is the Fundamental Counting Principle. This will instruct us that 8 objects can be arranged in $8!$ or 8P_8 ways.
- Another aspect of the Fundamental Counting Principle, using the concept of the product of the above choices, results in $({}^9C_2)({}^8P_8)$.

In this context, the example above plays an introductory role. However, the same example has been used as an overview, which has subtle differences, and has the characteristics of a limiting example (discussed below). It is important to reiterate that the various contexts in which the example is mobilized remains a function of teaching intention.

5. Limiting

By limiting, I mean examples that are indicative of the most difficult or complex type of problem that students should be expected to do. Limiting examples are not typically used until well into a unit, if we have made the logical progression of basic to

complex material. Although contradictory, some aspects of a limiting problem are also qualities that may prove useful at or near the beginning of a unit. In that case, limiting examples may function as introductory and/or give an overview, providing students with a glimpse of the coming landscape. This is by no means a “gentle” means of introduction, but is used to generate interest and engage students. Careful judgement is required as to whether this will have a detrimental effect, and so avoid the proliferation of confusion and frustration.

Example 11.

What is the probability that at least two students in this class have the same birthday?⁹

This is a limiting example due to its complexity. The concepts contributing to its solution are clear enough. In combination, these prove daunting to the typical student.

- The essential concept of theoretical probability: dividing the number of successful outcomes by the number of all possible outcomes.
- Previously learned combinatorics concepts are employed: 1) Determining the number of different ways 30 students can have birthdays - this involves choices times choices times choices, or $(365)(365)(365)\dots$ (Fundamental Counting Principle); 2) We require the number of ways 30 people can have different birthdays. For this, we use the number of permutations, ${}_{365}P_{30}$.
- An indirect approach is required. Students must realize the sheer size of the problem of finding the total number of ways that at least two people have the same birthday. This is easily avoided by simply finding the probability that everyone has a different birthday from one, leaving us with the answer:

$$1 - \frac{{}_{365}P_{30}}{(365)^{30}}$$
- in a typical classroom, it can usually be confirmed that there are two students (or more) with the same birthday. If not, it can lead to a good discussion on the implications of probability.

⁹ Adapted from British Columbia Principles of Mathematics 12 Examination Specifications, 2001

Example 12.

If $\log_9 5 = x$ and $\log_{27} 2 = y$, express $\log_3 100$ in terms of x and y .¹⁰

This is a limiting example due to its difficulty level. Logarithm problems involving change of base typically prove challenging for students. One of the reasons for this is that, unlike typical problems of the past, there is no single clear solution method prescribed. To proceed, the connection must be made that the common element in the problem is the base three:

$$\begin{aligned}\text{Part 1: } \log_{27} 2 &= y \\ 27^y &= 2 \\ 3^{3y} &= 2 \\ \log_3 2 &= 3y\end{aligned}$$

$$\begin{aligned}\text{Part 2: } \log_9 5 &= x \\ 9^x &= 5 \\ 3^{2x} &= 5 \\ \log_3 5 &= 2x\end{aligned}$$

$$\begin{aligned}\text{Part 3: } \log_3 100 & \\ &= \log_3(25 \cdot 4) \\ &= \log_3(5^2 \cdot 2^2) \\ &= \log_3(5^2) + \log_3(2^2) \\ &= 2\log_3(5) + 2\log_3(2) \\ &= 2(2x) + 2(3y) \\ &= 4x + 6y\end{aligned}$$

This problem provides an extensive workout with the laws of logarithms. With experience, the likelihood of proceeding correctly and efficiently increases dramatically.

¹⁰ BC Ministry of Education Mathematics 12 Exam, 1991

The next example is limiting not due to its difficulty level, but in its demonstration of the extent of my interpretation of the curriculum.

Example 13.

If α is a quadrant I angle with $\tan \alpha = \frac{3}{8}$, and θ is a quadrant II angle with $\cos \theta = -\frac{5}{13}$ and calculate the following (exactly):

- a) $\cos 2\alpha$
- b) $\cos (\theta - \alpha)$
- c) $\sin \left(\theta + \frac{\pi}{6} \right)$

The term “exactly” implies the use of fractions, radicals and known identities and formulas. The following combination of tasks contributes to the overall limiting aspect of this problem:

- Using standard position diagrams, the unknown sines and cosines of α and θ are determined since these will be needed for the double angle and angle sum and difference identities:

$$\sin \alpha = \frac{3}{\sqrt{73}}, \quad \cos \alpha = \frac{8}{\sqrt{73}}, \quad \sin \theta = \frac{12}{13}, \quad \cos \theta = -\frac{5}{13}$$

- For the special angle $\frac{\pi}{6}$, $\sin \frac{\pi}{6} = \frac{1}{2}$, $\cos \frac{\pi}{6} = \frac{\sqrt{3}}{2}$
- The problem reduces to the insertion of the correct trigonometric ratio into a double angle identity for a), for example:

$$\begin{aligned} \cos 2\alpha &= \cos^2 \alpha - \sin^2 \alpha \\ &= \left(\frac{8}{\sqrt{73}} \right)^2 - \left(\frac{3}{\sqrt{73}} \right)^2 \\ &= \frac{64}{73} - \frac{9}{73} \\ &= \frac{55}{73} \end{aligned}$$

- Using given sum and difference formulas for b) and c).

The problem also contains several subtle reminders of previous concepts, such as the use of a pythagorean triple in the reference triangle for angle β , and the use of special angles. Students ignoring the exact requirement will attempt to solve for the angles by calculator and then obtain the required sines and cosines of those angles. This method can be used to check for correctness of the *exact* answers.

6. Contrasting

Examples with superficial or structural similarities are presented together or in succession, in order to compare and highlight fundamental differences in methods of approach. Two cases are shown below:

Example 14.

Solve, $0 \leq x < 2\pi$:

$$\text{a) } \cos x = -\frac{1}{\sqrt{2}} \qquad \text{b) } \sin x = -0.450$$

Both of the above must be considered in a similar framework, and yet the details of their solutions processes are quite different. Part a) should be solved by recognizing the special angle aspect: placement of a $\frac{\pi}{4}$ reference angle in quadrants II and III to obtain the two solutions for the angle x , $\frac{3\pi}{4}$ and $\frac{5\pi}{4}$. This is typical of those problems requiring a “non-calculator” solution and “exact answers”. Part b) requires not only a

calculator-aided solution, but the knowledge of how to correctly apply that information to obtain the solutions in quadrants III and IV:

$$\sin^{-1}(-0.450) \approx -0.4668$$

$$x_1 \approx \pi + 0.4668$$

$$\approx 3.6084$$

$$x_2 \approx -0.4668 + 2\pi$$

$$\approx 5.8164$$

$$x = 3.61, 5.82$$

Example 15.

Solve:

$$\text{a) } \left(\frac{1}{16}\right)^{x+3} = 64^{5-2x} \qquad \text{b) } 2^x = 5^{2x-1}$$

Both of the above require solving for unknown exponents. Part a) can and should be solved using base 2 or 4, reducing the problem to a simple algebraic equation:

$$\left(\frac{1}{16}\right)^{x+3} = 64^{5-2x}$$

$$\left(2^{-4}\right)^{x+3} = \left(2^6\right)^{(5-2x)}$$

$$-4(x+3) = 6(5-2x)$$

$$-4x-12 = 30-12x$$

$$8x = 42$$

$$x = \frac{42}{8} = \frac{21}{4}$$

Part b) requires the use of logarithms and more algebraic manipulation, depending on the approach. Although part a) could be solved using logarithms (below), it is not recommended as the best use of student time or resources.

$$\begin{aligned}
2^x &= 5^{2x-1} \\
\log 2^x &= \log 5^{2x-1} \\
x \log 2 &= (2x-1) \log 5 \\
x \log 2 &= 2x \log 5 - \log 5 \\
\log 5 &= 2x \log 5 - x \log 2 \\
\log 5 &= x(2 \log 5 - \log 2) \\
x &= \frac{\log 5}{(2 \log 5 - \log 2)}
\end{aligned}$$

7. Consolidating

Consolidation is the process of drawing together various concepts and procedures, to assist with clarifying new or previously learned concepts. In this sense, it can be differentiated from review, which is the reiteration of previously learned or presented material. In examples, consolidation can be manifested by using any number of previously visited ideas and demonstrating relationships among these. It may involve the integration of these ideas to assist in the solution of a new problem. Alternately, it may involve a spiralling effect, pulling together the necessary ideas again and again as they are needed. In all of the above cases, consolidation is an ongoing aspect of teaching that can be found in virtually all worked examples. Video evidence of my lessons confirms that there is a continuous background “noise” of consolidation. It has become an ingrained and automatic aspect of my teaching, constantly reminding, reviewing, and emphasizing links. Students may be experiencing varying degrees of review and/or consolidation, depending on how well they have learned the background material. When attempting to link back to poorly or partially learned concepts, students have an

opportunity to improve their comprehension. Partial understanding is a teaching intention examined in the next chapter.

Example 16.

In a standard 52-card deck, how many different 5-card hands are possible which contain exactly one pair?

This problem is approached through the connection of the following distinct sub-problems, each of which is a previously learned topic:

- How many card ranks are possible? The pair of cards must consist of a single rank. How many card ranks are possible? 13, or specifically ${}_{13}C_1$, if we consider the number of ways a rank may be chosen;
- How many ways can the pair be chosen from the 4 cards of a single rank? Of 4 possible cards in each rank, we need groupings of 2 to form the pair, or ${}_4C_2$ different ways.
- How many different ways are there to get the 3 remaining cards, and how can we ensure that these 3 cards are different from each other and different from the pair? The 3 remaining cards must be chosen from among the 12 remaining ranks. Combinatorics gives us the means to determine the number of ways to select 3 different objects from 12, using ${}_{12}C_3$.
- Once again, each of the 3 different ranks is made up of 4 possible cards. This means that there are $({}_4C_1)^3$, or 4^3 different ways to select specific cards.
- How do we put this information together? Each of the above components contributes to the calculation, using the Fundamental Counting Principle concept of choices times choices times choices; $({}_{13}C_1)({}_4C_2)({}_{12}C_3)({}_4C_1)^3$.

By linking several simpler problems, and emphasizing how each contributes to the overall more complex calculation, more meaning is given to the previous ideas. This is the essence of consolidation, in which the tying together of previous work results in better understanding of those while simultaneously extending to further and more complex concepts.

Example 17.

Determine the equations of the asymptotes of the function $y = \tan bx$, where $b > 0$.¹¹

This example consolidates the graphical behaviour of the tangent function and the transformation brought about by the constant b '.

- Review of the graphical properties of the tangent function: vertical asymptotes of lie at $x = \frac{\pi}{2}$ plus integer multiples of the period of the function, which is π radians: $x = \frac{\pi}{2} + n\pi, n \in I$
- Review of the effect of the b in a function $y = f(bx)$: b is a horizontal compressing factor.
- The asymptote locations, $x = \frac{\pi}{2} + n\pi, n \in I$, are divided by “ b ”, and thus are located at $x = \frac{\pi}{2b} + \frac{n\pi}{b}, n \in I$.

8. Extending

Extension is a common occurrence in which one example or task is used as a base for developing a further exploration, or a more complex idea. Many of these are planned, but frequently they are spontaneous, and of those, extensions can be one way to address student questioning.

Example 18.

a) An earthquake registers 8.6 on the Richter Scale. How many times more intense is another earthquake with Richter scale 9.9?

¹¹ BC Ministry of Education June 2003

$$\frac{10^{9.9}}{10^{8.6}} = 10^{9.9-8.6}$$

The extension part b) involves a more complex idea and fuller understanding of logarithmic behaviour and properties of logarithms than part a).

b) What is the Richter Scale of an earthquake 5000 times less intense than a 7.5 Richter scale earthquake?

$$\log\left(\frac{10^{7.5}}{5000}\right) \text{ or } 7.5 - \log 5000$$

Example 19.

Determine the period and the amplitude of the function $y = k \sin \theta \cos \theta$.

The example itself acts as an extension of our typical work, in a double-angle identity application with which students often have difficulty.

$$y = k \sin \theta \cos \theta$$

$$k \sin \theta \cos \theta = \frac{k}{2} (2 \sin \theta \cos \theta)$$

$$\text{Since } 2 \sin \theta \cos \theta = \sin 2\theta$$

$$\frac{k}{2} (2 \sin \theta \cos \theta) = \frac{k}{2} (\sin 2\theta)$$

$$y = \frac{k}{2} (\sin 2\theta)$$

From our previous study of these types of functions, we determine that the amplitude is

$\frac{k}{2}$ and the period is π .

Example 20.

What is the interest rate required to increase an initial amount by a factor of ten in ten years?

It is perhaps no coincidence that many ‘extension’ examples also act as those problems used to ‘point out common errors and difficulties’, which is discussed in the next chapter. This is such an example, extending the basic idea of exponential growth. The expected “exponential growth” types of problems are those which a) determine a final amount, and b) determine a time or a half-life required for a specified exponential growth or decay. Here students are asked to extend those ideas by turning the equation around to solve for the growth rate:

$$\begin{aligned} \text{Annual growth rate } i : A &= A_0(1+i)^t \\ 10 &= (1)(x)^{10} \\ x^{10} &= 10 \\ x &= 10^{\frac{1}{10}} \approx 1.2589 \\ i &= 0.2589 \end{aligned}$$

This calculation yields a per cent growth of 25.89% if assumed to be an annual interest rate, compounded yearly. Although financial matters are typically conducted with annual growth rates, this is not necessarily that type of question, and such an assumption should be questioned and discussed. If a continuous growth rate is needed, we extend further:

$$\begin{aligned} \text{Continuous compounding: } A &= A_0e^{it} \\ 10 &= (1)e^{(i)10} \\ \ln 10 &= 10i \\ i &= \frac{\ln 10}{10} \approx 0.2303 \end{aligned}$$

This gives a continuous compounded rate of 23.03%, which can be compared to the annual growth rate determined above.

9. Cross or Multi-topic

Examples in this context draw from more than one distinct curricular unit, possibly incorporating seemingly unconnected concepts, perhaps in surprising and unexpected ways. Cross-topic questions are a means to emphasize relationships between and among curricular “units”. In a well-sequenced course, there should be a natural emergence of problems linking various topics as the course progresses, building on previous work. An example is the transformations of trigonometric or logarithmic functions after an initial unit on general transformations. The type of cross-topic problems I am referring to are those that tie together concepts in unusual or novel ways.

Example 21.

Two teams are involved in a sudden-death shoot-out, in which the first team to score wins. Team 1 has a 0.70 probability of scoring on each of their attempts, and team 2 has a 0.80 chance of scoring on each of their attempts. If team 1 shoots first, determine the probability that they will win.¹²

Although an unlikely scenario as a real-life application, the probabilities for the first few trials can be constructed/calculated. It becomes evident that this shoot-out may go on indefinitely. A pattern emerges, in which the answer is an infinite geometric series. Probability and infinite series are not typically combined in this course. The calculation of probabilities, likely from a probability tree, yield:

- $P(\text{team 1 wins}) = 0.7 + (0.3)(0.2)(0.7) + ((0.3)(0.2))^2(0.7) + ((0.3)(0.2))^3(0.7) + \dots$

¹² Adapted from Mathematics 12, Pearson (2000)

- The above expression forms an infinite geometric sequence with common ratio $(0.3)(0.2)$

- Using the sum of an infinite geometric series:

$$S = \frac{a}{1-r}$$

$$= \frac{0.7}{1-(0.2)(0.3)} \approx 0.7445$$

The probability team 1 wins is about 74%.

Example 22.

Given the function $f(x) = \log_a x$, which of the following would best describe $y = \log_{\frac{1}{a}} x$?

A. $y = f(-x)$

B. $y = -f(x)$

C. $y = f^{-1}(x)$

D. $y = -f(-x)$

E. $y = \frac{1}{f(x)}$

This problem is not necessarily a cross-topic question. It depends on how a student approaches its solution. It is linked to the transformation unit covered earlier by students in specific use of notation taken from that unit in the answer choices. It may be that each of the choices is examined in turn, where a) is a reflection in the y -axis, b) is the correct answer, a reflection in the x -axis, c) is the inverse, d) is both a) and b) reflections, and e) the reciprocal of $f(x)$. Below are two ways to determine the answer using logarithmic concepts, if a student does not realize that the reflection in the x -axis, $-f(x)$, is the only reasonable answer:

Method 1:

Change the log equation to its exponential form and then back:

$$y = \log_{\frac{1}{a}} x$$

$$\left(\frac{1}{a}\right)^y = x$$

$$\left((a)^{-1}\right)^y = x$$

$$(a)^{-y} = x$$

$$-y = \log_a x$$

$$y = -\log_a x = -f(x)$$

Method 2:

Take the reciprocal of the base and the argument:

$$y = \log_{\frac{1}{a}} x$$

$$y = \log_a \frac{1}{x}$$

$$y = \log_a x^{-1}$$

$$y = -\log_a x$$

$$y = -f(x)$$

10. Uncommon or Exceptional Case

These examples have unusual or special significance, which may be due to their technological, cultural, historical, or simply mathematical interest. Such examples differ from those “limiting” examples, which are constrained by curriculum. Certain examples may be considered exceptional in the context of the course material, in that they would typically not be seen by students. Such examples are often outside the specified curriculum, but have attributes worth exploring.

Example 23.

Maclaurin Series: $\sin x = x - \frac{x^3}{3!} + \frac{x^5}{5!} - \dots$

This task involves the use of a graphing calculator to show how the polynomial ultimately converges with the sine function (Figure 6). The existence of such relationships, and their applications, forms a useful discussion. It is not my purpose to examine how these series are derived, but to generate interest.

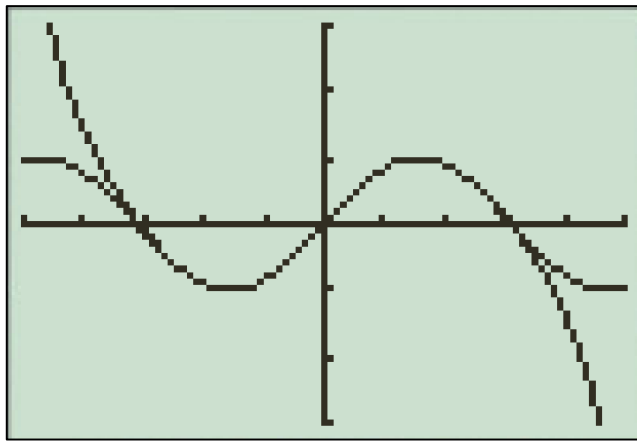

Figure 6: Maclaurin Series

Example 24.

Evaluate: $\lim_{x \rightarrow \infty} \left(1 + \frac{1}{x}\right)^x$

The topic of limits is usually restricted to Calculus courses. However, the current Principles of Mathematics 12 curriculum contains learning outcomes involving the use of e , the natural logarithm, and applications of continuous exponential growth¹³. This limit

¹³ For the new Pre-calculus 12 course slated for implementation in September 2012, there is no sign of the natural logarithm.

affords an accessible method of demonstrating a convergence to e , through “brute force”, where numbers are substituted into the expression:

$$\left(1 + \frac{1}{10}\right)^{10} \approx 2.59374$$

$$\left(1 + \frac{1}{100}\right)^{100} \approx 2.70481$$

$$\left(1 + \frac{1}{10^6}\right)^{10^6} \approx 2.71828$$

CHAPTER 5: TASKS AND EXAMPLES: TEACHING INTENTION

In Chapter 4, I discussed the kinds of examples and tasks used in terms of their context, which is analogous to their ‘location’ in my teaching. Here I consider the purposes and goals of the use of tasks and examples in my teaching process, which fall under the general organizer referred to as “intention”. A number of descriptors are identified, through which I attempt to explain why these examples and tasks are used, and what I expect and hope the students to experience – allowing that these are potential outcomes. Those intentions identified are as follows:

- Standard
- To Level
- To Create Cognitive Dissonance
- To Stimulate Inquiry
- To Create Partial Understanding
- To Point Out Common Errors And Difficulties
- Structured Variation
- To Overload
- To Pre-Familiarize With Upcoming Topics
- To Create A Platform For Future Scaffolding
- Across The Grain

These intentions form a wide-ranging and disparate conglomeration of concepts, properties and techniques. These labels chosen consist of direct and metaphorical

descriptors best express the reasons for using tasks and examples that have arisen from the study of their classroom implementation. Teaching intention is subject to change depending on their viability as the lesson proceeds. Some of these intentions are linked to others; some are either directed toward or experienced by different groups of students at different times. Since the intentions are linked to potential outcomes, students may experience unintended outcomes. An example of this might involve an “across the grain” approach, which also results in levelling, which is desirable. This approach may also generate overload or cognitive dissonance, which may not be desirable. In certain cases, it is difficult to discern between those aspects of lesson ‘context’ (Chapter 4), and the intentions outlined in this chapter. In the formulation of this categorization system, I have pointed some problems and limitations of deconstructing context and intention into separate entities. For instance, the distinction between the use of examples in a “contrasting” Context, and the teaching Intention of using a series of examples for “structured variation” may not be clear. However, there are sufficient differences among the major categories and their subdivisions that merit their separate treatment.

It became obvious that some of the intended outcomes cannot result from the implementation of single examples or tasks. They may coalesce over groups or series of problems, or be a function of time. Examples of this include the strategy of creating “partial understanding”, and the purposeful inducement of “cognitive dissonance”. In both of the above, it is implicit that I would attempt to resolve any student issues with course material over time. A number of different strategies are employed to accomplish my teaching goals as the students have a wide range of abilities and learning styles. A wide-spectrum approach reflects my attempt to address this aspect of my students, hoping

that some of these will be successful, and appreciating that they may not. As with the previous chapter examining ‘context’, a description of each intention will follow, illustrated with actual problems used for those purposes. In the exploration of my teaching goals, I must point out that, although experience and evidence exist to indicate that these intentions are realized to some extent, it is not my purpose to report on the success of these endeavours, or to justify them.

1. Standard

The reasons for using tasks and examples can be complex. However, in my analysis, it became clear that there are also very straight-forward teaching motives. These are an aspect of what can be considered standard teaching practice, which is discussed in Chapter 1. In the absence of complex pedagogical purposes or ulterior motives for using tasks and examples, it is useful then, to have a ‘standard’ example as the first category. In this case, an example or problem may be used to demonstrate a concept or technique. However, from a student perspective, receptiveness and appreciation of any pedagogical intent cannot be assumed. As well, virtually any example, depending on presentation and chronological placement, could be considered to be typical. It is the rearrangement of typical aspects of sequencing, presentation and minutiae of teaching that create opportunities for more elaborate types of intention. Consider the following example:

Example 25.

A population doubles every 12 years. How long will it take to triple?

$$A = A_0(2)^{\frac{t}{12}}$$

$$3 = 1(2)^{\frac{t}{12}}$$

$$\log 3 = \frac{t}{12} \log 2$$

$$t = \frac{12 \log 3}{\log 2} \approx 19.02 \text{ years}$$

There is nothing remarkable about this problem. It is used to demonstrate the application of logarithms in solving the general exponential equation $A=A_0(2)^{\frac{t}{12}}$. This problem has the potential of being used for a number of teaching purposes, or intentions. It might have been used to “level”, the process of ensuring widespread understanding, discussed in the next section. The problem could be used to point out common errors and difficulties which students have in exponential growth questions of this type. The problem may be used to “stimulate inquiry”, in its demonstration that all exponential growth can be construed to have a doubling time, tripling time, a per cent growth rate, or any number of representations. This line of thought can also lead to the teaching intention of “pre-familiarizing with upcoming topics”, such as continuous exponential growth. Further, as shown in example 44 later in this chapter, such a problem can be used with an “across the grain” intention. These more elaborate “intentions”, discussed in this chapter, lie in contrast to the simplicity of the so-called “standard” intention.

2. To Level

I use the term levelling to describe the process of attempting to bring as many students as possible up to a reasonable level of competency. In practice, the teaching

process cannot effectively be pushed beyond a pace that is dictated by the characteristics of the central group of mid-level performers. Unfortunately, the system is bound by time constraints, which creates difficulties for those students requiring more time to understand and gain mastery of coursework. There are always capable and less capable students, as well as those who learn at different rates and in different ways, and have a range of motivation levels. Attempts to work within these constraints, to expedite and accelerate learning, is the focus of certain other “intentions” discussed in the following sections of this chapter. Levelling serves to stabilize class progress and check for understanding, competency and/or mastery of curricular material. While striving to achieve relative uniformity in students’ levels of understanding, levelling is used to provide opportunities for clarification of instruction. It is most typically carried out through discussion of solutions to tasks that may include homework, quizzes and assessments. Any reasonable problem may be used as a vehicle to accomplish this, as long as it allows opportunities for review and consolidation (which have been presented as “contexts” for the use of examples). The following example uses levelling to reiterate various methods with which to handle logarithm problems involving different bases. It may appear to be no different than a typical or introductory example on this topic except for its chronological placement, and the resulting nuances of its presentation.

Example 26.

Simplify: $\log_9 3\sqrt{3}$

This problem may be approached using base 3 or base 9. One point we make is that ultimately it does not matter, as long as the method uses valid mathematics. Taking a base 9 approach:

$$\begin{array}{lcl}
\text{Base 9: } \log_9 3\sqrt{3} & & \log_9 3\sqrt{3} \\
= \log_9 \sqrt{3 \times 3 \times 3} & \text{or} & = \log_9 3\left(3^{\frac{1}{2}}\right) \\
= \log_9 \sqrt{27} & & = \log_9 3^{1+\frac{1}{2}} \\
= \log_9 \left(3^3\right)^{\frac{1}{2}} & & = \log_9 3^{\frac{3}{2}} \\
= \log_9 3^{\frac{3}{2}} & & \\
= \log_9 \left(3^2\right)^{\frac{3}{4}} & & \\
= \log_9 \left(9\right)^{\frac{3}{4}} & & \\
= \frac{3}{4} & &
\end{array}$$

The worked solution above refers students back to the central idea in logarithms of “matching bases”, as indicated by the identity $\log_a a^x = x$. The levelling I seek to achieve takes place in ensuring that the radical arithmetic from previous years, and use of the laws and identities of logarithms are understood and accessible. In this process, I use the base 9 approach (above). Other approaches can be shown if prudent, but do not necessarily promote the intention of levelling, but rather tend toward an “across the grain” approach. The following alternative approach is presented using another commonly occurring technique in which we convert an exponential equation to a logarithmic form and vice-versa:

$$\begin{array}{l}
\text{let } x = \log_9 3\sqrt{3} \\
9^x = 3\sqrt{3} \\
\left(3^2\right)^x = 3\sqrt{3} \\
\left(3\right)^{2x} = 3\sqrt{3} \\
\left(3\right)^{2x} = \left(3\right)^{\frac{3}{2}} \\
2x = \frac{3}{2} \\
x = \frac{3}{4}
\end{array}$$

The above method is slightly more problematic for some students as it requires the insertion of a variable which is absent from the original problem statement. As well, the use of different methods begins to veer away from the intention of levelling to others, such as working across the grain, discussed later in this chapter. The next case is taken from an assessment task and its subsequent in-class worked solution (see Appendix, Transcript 1):

Example 27.

Determine the inverse $f^{-1}(x)$ if $f(x) = 2 \log_3(x+2)$

$$f(x) = y = 2 \log_3(x+2)$$

$$x = 2 \log_3(y+2)$$

$$\frac{x}{2} = \log_3(y+2)$$

$$3^{\frac{x}{2}} = y+2$$

$$y = f^{-1}(x) = 3^{\frac{x}{2}} - 2$$

Students had difficulty with the leading “2”, which, brought up as an exponent to give $y = \log_3(x+2)^2$, often led to difficulty. The problem was solvable at this stage, but few students who took this route were able to get there:

$$x = \log_3(y+2)^2$$

$$3^x = (y+2)^2$$

$$(3^x)^{\frac{1}{2}} = 3^{\frac{x}{2}} = y+2$$

$$3^{\frac{x}{2}} = y+2$$

$$y = 3^{\frac{x}{2}} - 2$$

Discussion of the different aspects of this problem – how to handle inverses, laws of logarithms and converting a logarithm to an exponential expression, all of which were not new at this stage of our progress, allowed for some levelling to occur.

3. To Create Cognitive Dissonance

In order to alter or replace certain ingrained, pre-conceived student notions that hinder or prevent progress in Grade 12 mathematics, it is necessary to bring about conceptual change. Undertaking this requires a concerted effort. One strategy for accomplishing this involves the intentional use of tasks and examples to create dissonance. Festinger (1957) put forward his theory of cognitive dissonance, stating that, “The existence of dissonance, being psychologically uncomfortable, will motivate the person to try to reduce the dissonance and achieve consonance” (p. 3). Observation of my classroom has led me to believe that I create dissonance in order to facilitate learning. This has become an innate aspect of my teaching. There are two conditions under which it is necessary to attempt to effect change in students perceptions and certain ingrained pre-conceived notions. This is when students’ existing ideas of how mathematics should be done begin to impair their ability to function reasonably, and are most typically found in the area of problem-solving and the refusal to use visual representations. .

The vast majority of examples used require, promote and are biased toward problem-solving. My teaching methods encourage the use of a minimal set of basic facts, and experience. Memorization of particular problem solution methods and rote learning,

which may have contributed to student success in the past is not sufficient to deal with the types of problems encountered in this course. Difficulty arises when students are asked to solve problems for which there has been no direct precedent, and where memorizing solution methods do not help. It is not the use of single problems themselves which promote dissonance, but likely the fact that this is the type of work that is emphasized, expected and assessed. The intention of creating cognitive dissonance is perhaps the most difficult to demonstrate. The examples chosen to illustrate how the development cognitive dissonance may be promoted are either problems of a complexity level requiring some problem-solving strategies, or those most efficiently solved with a graphical or other visual approach (or perhaps both).

Example 28.

How many different ways are there to arrange the letters in the word PARALLEL such that no L's are together?

Basic arrangements and permutations for simpler examples had been considered. For example, from our coursework, it was well known that the number of 8-letter

permutations of PARALLEL would be $\frac{8!}{2!3!} = 3360$. A direct approach would be to

consider the ways that the L's could be separated.

To solve this problem, a visual approach can provide a structure. The letters P, A, R, A, and E can be arranged around the separated L's in $\frac{5!}{2!}$ ways. Possible patterns for the arrangements of separated L's are as follows:

L		L		L			
	L		L		L		
		L		L		L	
			L		L		L

There are 4 ways to have this separation pattern;

L		L			L		
	L		L			L	
		L		L			L

There are 3 ways to have this separation, but this number can be doubled for reverse symmetry: 6 ways;

L		L				L	
	L		L				L

There are 2 ways to have this separation, but this number can be doubled for reverse symmetry: 4 ways;

L		L					L
---	--	---	--	--	--	--	---

L			L			L	
---	--	--	---	--	--	---	--

L				L			L
---	--	--	--	---	--	--	---

There are 2 ways to have each of the above patterns, those shown and the reverse of each: 6 ways;

The total number of possible patterns to separate the L's is 20. The product of 20 and the number of possible arrangements of the other letters, $\frac{5!}{2!}$, yields 1200 unique arrangements.

An indirect approach to this problem could be to subtract the number of ways that the L's could be together, in groups of 3 or 2, from the total number of permutations, 3360. In either case, since there is no direct precedent for such a problem in our course, students must use basic principles and reasoning to begin to find solutions. In other words, they must problem-solve. This can contribute to dissonance in the sense that student expectations do not align with my demands and requirements with respect to problem-solving.

An increasing emphasis on visualization, primarily in the area of the graphical representation of functions, is an important aspect of Grade 12 mathematics. My experiences indicate various levels of student reluctance to accept and therefore

appreciate the utility of these visualizations in understanding course content and in problem-solving. Graphical methods, which can both assist and consolidate algebraic approaches, may be used in both of the following examples:

Example 29.

Solve: $\cos 3x = -1, 0 < x < 2\pi$

I teach a graphical method (Figure 7), which appears to me to be the natural way a student should approach this type of problem. The behaviour of the cosine function is well known, and the fact that it is then compressed by a factor of 3 yields 3 solutions in the required domain: $x = \frac{\pi}{3}, \pi$ and $\frac{5\pi}{3}$.

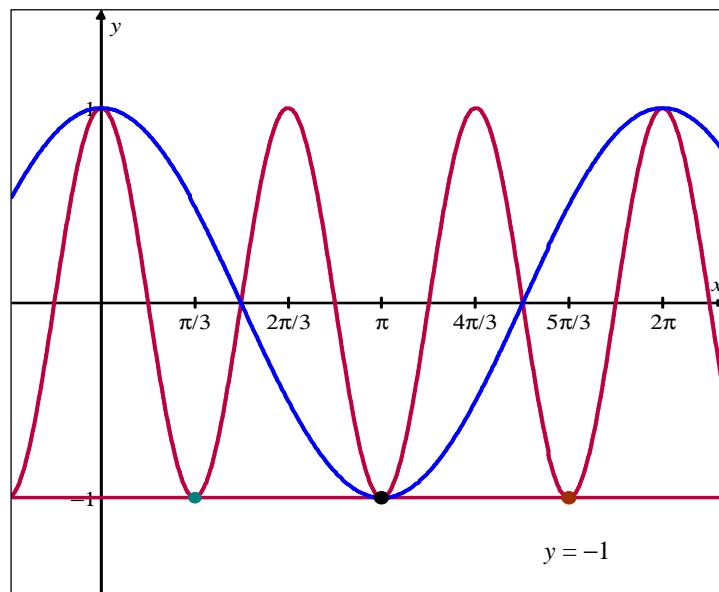

Figure 7: Solving $\cos 3x = -1$

Example 30.

The smallest positive zero of the function $y = \cos k\left(x + \frac{\pi}{8}\right)$ occurs at $x = \frac{\pi}{2}$. Find k if $k > 0$.¹⁴

To solve graphically:

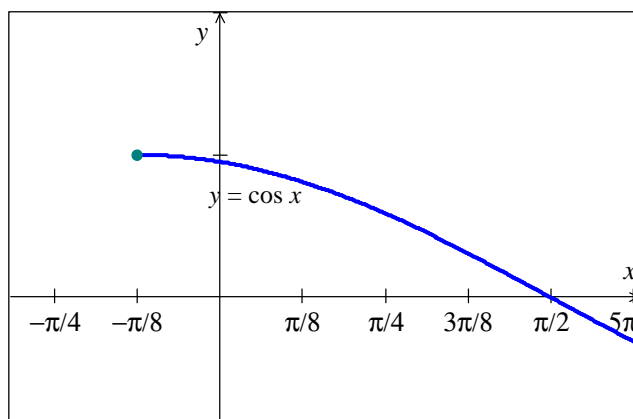

Figure 8: Graphical Approach for $y = \cos k\left(x + \frac{\pi}{8}\right)$

- The cosine function maximum is transformed $\frac{\pi}{8}$ units to the right from $x = 0$, and graphed from the point $\left(-\frac{\pi}{8}, 1\right)$ to its first root at $x = \frac{\pi}{2}$. The distance from this maximum at $-\frac{\pi}{8}$ to the positive zero at $\frac{\pi}{2}$ is $\frac{5\pi}{8}$. This distance equates to one quarter of the period, giving a full period of $\frac{20\pi}{8}$ or $\frac{5\pi}{2}$. The value k is found from the relationship $\text{period} = \frac{2\pi}{k}$, giving $k = \frac{4}{5}$. Yet many students would solve the problem non-graphically in this way:

¹⁴ Ministry of Education, 1994

$$y = \cos k \left(x + \frac{\pi}{8} \right)$$

$$0 = \cos k \left(\frac{\pi}{2} + \frac{\pi}{8} \right)$$

$$0 = \cos k \left(\frac{5\pi}{8} \right)$$

$$\frac{\pi}{2} = k \left(\frac{5\pi}{8} \right)$$

$$k = \frac{4}{5}$$

Perhaps the means achieve the end, but I am left with an uneasy feeling that these students have missed the point. I consider the graphical approach to be inherently superior since it affords a visual context with which to make sense of the relationships we are examining.

The factors contributing to the creation of cognitive dissonance identified above, related to problem solving, visualization (primarily graphical) and the resulting issues in mathematical competency, arise from my conscious attempts to address a disparity in actual student ability levels and my perception of levels appropriate to achieve the goals of this course.

4. To Stimulate Inquiry

There are several possibilities through which the use of tasks and examples can stimulate inquiry. Some students are genuinely interested in the coursework. However, as we begin to explore some interesting applications of mathematics, satisfaction, and

even joy of discovery and mastery seem to become increasingly elusive for the average student. Evident in many tasks and examples is an attempt to engage students, through connections to actual or plausible events, to ascribe meaning through relevance, or to provide mathematically interesting yet accessible problems. Such problems are not necessarily connected to curriculum. Regardless of the interest level of the course material or any particular example, students may choose to not engage. The example below, originally an assessment item, creates a dilemma for the thoughtful student. The purpose of this question is to encourage some thought toward the use of mathematical models and their limitations, beyond mechanical substitution of numbers into equations:

Example 31.

There are approximately 10 000 of an endangered sushi fish species left. The population is decreasing at 8% per year. At this rate, how long will it be before extinction?

- A. 30 years B. 60 years C. 90 years D. 120 years E. never

Possible answers to this question might be c), which gives 5.5 fish remaining; or D), 0.45 fish remaining. A better answer, pointed out to the group in the aftermath of the assessment, would be a range, say 90 to 120 years, incorporating the “real-life” and “approximate” nature of the question. A similar example asks students to determine when a car depreciating at 15% per year will be worthless, which leads to a discussion in the suitability and practicality of mathematical models. The following example provides an opportunity to explore some variations on a standard type of problem:

Example 32.

You are at a point (0, 0) on an x - y grid and must move to the point (10, 10), moving only in the positive x and y directions (on lattice points).

- How many different paths can be taken?
- If you must pass through the point (3, 7), how many different paths are possible?
- If you cannot pass through the region shown (Figure 9), how many different paths are still possible?

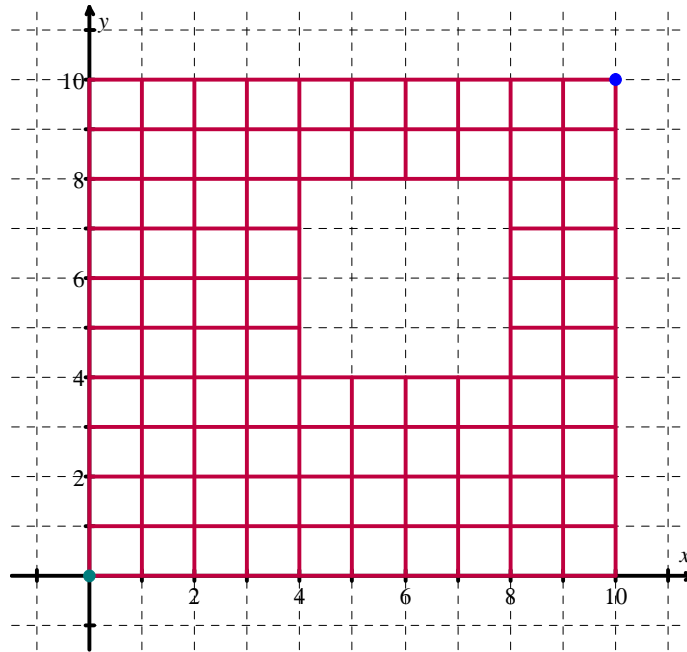

Figure 9: Pathway Problem

This problem is a slight twist on a standard “pathway” question.

- Part a) can be solved using an application of the Fundamental Counting Principle, $\frac{(10+10)!}{10!10!}$. Students may also determine the number of pathways by using basic summation principles in determining the number of ways to get each lattice point in turn.
- Part b) can be treated by multiplying the number of pathways from two smaller grids, one with dimensions 3 units by 7 units, and the other, 7 units by 3 units: $\left(\frac{(3+7)!}{3!7!}\right)\left(\frac{(7+3)!}{7!3!}\right)$.

- Part c) normally requires the basic principles approach of taking each lattice point or node in turn, starting from point $(0, 0)$, and working around the open region.

The problem above provides opportunities for exploration in seeking a combinatorial solution to part c), instead of working through each lattice point. A further variation of the pathway question is shown below:

Determine the number of ways in which you can get from point A to point B, moving in the direction of point B:

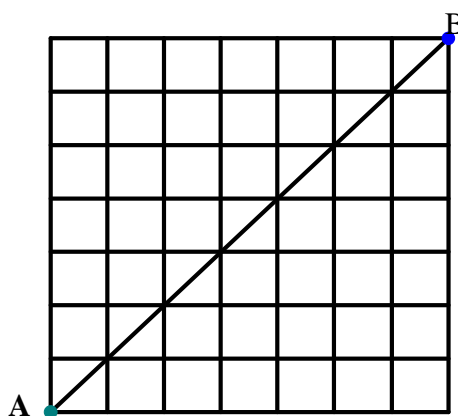

Figure 10: Pathway Problem Variation

This problem was used on a combinatorics unit test, and as such, precluded any attempts to find a more elegant solution beyond that of “brute force.” The examples used, especially part c) and the pathway problem shown in Figure 10, are extensions that also exceed the parameters of the learning outcomes in the course. It is hoped that the use of mathematically interesting and thought-provoking problems serves to engage students.

5. To Address Common Errors and Difficulties

A number of problems are used to point out their “problematic” aspects. Experience in the delivery of this course provides insights in identifying those concepts and procedures likely to cause difficulties. Video evidence shows a continuous emphasis on error prevention awareness during worked examples, alerting students to potential trouble spots and common student errors. For many examples used, pointing out common errors and difficulties is not necessarily the primary reason for their selection and use, but is an embedded aspect of almost all worked-examples. In an example considered previously, (Example 3, “The terminal arm of an angle θ in standard position passes through the point (3, 8). Determine $\sin \theta$, $\cos \theta$, $\tan \theta$ and θ .”), the determination of angles in standard position using inverse sine, cosine and tangent, proves to be a common source of difficulty. Specifically, the problem lies in the interpretation of radian measures obtained from calculators. Proper procedures and potential errors are emphasized to students through the worked examples. Issues in interpreting angle measures for standard position angles greater than $\frac{\pi}{2}$, or 90° can usually be resolved with the use of or assistance of diagrams. As described earlier in the discussion of cognitive dissonance, a resistance to use a visual approach can lead to problems.

The following examples present challenges to students from a problem-solving point of view. Both require some manipulation to allow them to be considered as more familiar cases, at which point they may become routine exercises:

Example 33.

$$\log_x 9 = -\frac{3}{2}$$

It is not necessarily the presence of a variable base in this logarithmic equation that is the source of problems for students. It is a relatively simple procedure to rearrange the equation into its exponential form: $x^{-\frac{3}{2}} = 9$. Students are surprised to find that the relatively simple identity, $(x^n)^{\frac{1}{n}} = x^1 = x$, can be used to obtain the answer:

$$\begin{aligned}x^{-\frac{3}{2}} &= 9 \\ \left(x^{-\frac{3}{2}}\right)^{\frac{2}{3}} &= (9)^{\frac{2}{3}} \\ x &= (9)^{\frac{2}{3}}\end{aligned}$$

Example 34.

Solve: $\cos \theta - 2 \sec \theta - 1 = 0$

Many of the problems presented to students which have mixed trigonometric functions are not solvable by simple algebraic methods such as factoring. This problem is contrived to make use of the reciprocal relationship between cosine and secant, and can be changed into a more recognizable factorable form:

$$\begin{aligned}(\cos \theta)(\cos \theta) - 2(\sec \theta)(\cos \theta) - \cos \theta &= 0 \\ \cos^2 \theta - 2 - \cos \theta &= 0 \\ \cos^2 \theta - \cos \theta - 2 &= 0 \\ (\cos \theta - 2)(\cos \theta + 1) &= 0\end{aligned}$$

The above examples point out common difficulties experienced by students. The errors that students typically make, beyond those in basic algebra and arithmetic operations (largely avoided or identified by checking work), are associated with their common difficulties. Procedural or mechanical errors stemming from incomplete understanding, or incomplete mastery of material. Through the identification of common difficulties, and their emphasis in worked examples, students are alerted to such pitfalls, and for the most part, can successfully avoid or navigate through them. An alternate solution for Example 15 b), used earlier, is shown below:

Example 35.

$$\text{Solve: } 3(2^x) = 5^{2x-1}$$

If the instruction is to “solve by algebra to 2 decimal places”, such approaches are typical:

$$\begin{aligned} 3(2^x) &= 5^{2x-1} \\ \log_5(3(2^x)) &= \log_5 5^{2x-1} \\ \log_5 3 + \log_5 2^x &= 2x - 1 \\ \log_5 3 + x \log_5 2 &= 2x - 1 \\ 0.68 + 0.64x &= 2x - 1 \end{aligned}$$

The solution above is essentially correct to the point shown, other than rounding off earlier than necessary. Some students run into trouble solving equations such as the one shown in the final step above. The following error is more common:

$$\begin{aligned} \log_5(3(2^x)) &= \log_5 5^{2x-1} \\ x \log_5(3(2)) &= 2x - 1 \end{aligned}$$

Further, early rounding often leads to incorrect solutions. Although any valid solution is acceptable, the recommended one is shown here:

$$\begin{aligned}3(2^x) &= 5^{2x-1} \\ \log(3(2^x)) &= \log 5^{2x-1} \\ \log 3 + \log 2^x &= (2x-1)\log 5 \\ \log 3 + x \log 2 &= 2x \log 5 - \log 5 \\ \log 3 + \log 5 &= 2x \log 5 - x \log 2 \\ \log 3 + \log 5 &= x(2 \log 5 - \log 2) \\ x &= \frac{\log 3 + \log 5}{2 \log 5 - \log 2} \approx 1.072\end{aligned}$$

6. To Create Partial Understanding

Partial understanding presents somewhat of a contradiction in my overall approach of working from well understood basic principles to solve problems. Wherever possible, I attempt to instil in my students a firm grasp of the underlying contributing knowledge, rules and procedures. Where, then, might it be possible to circumvent the mastery of basics, and achieve our goals without complete understanding? Hewitt (1996) discussed the idea of “subordination of skills”, in which he expresses the idea that, “If you want to practise walking... then start learning to run” (p. 28). “The desirability of immediately subordinating something which is to be learned, is that practice can take place without the need for what is to be practised to become the focus of attention” (ibid., p. 34). If total mastery is not feasible, certain building blocks which a student should have may be sacrificed temporarily or permanently. An example of the latter case is

demonstrated in some students' understanding of proofs of trigonometric identities. Little actual understanding of trigonometry is required, other than the use of given identities, combined with algebraic manipulation, in order to achieve success. This example, however, is a type of short-circuiting, and does not demonstrate characteristics of partial understanding that may result in acceleration of the learning process.

In most cases, it is desirable, if not imperative, for students to have a firm foundation prior to proceeding. Partial understanding results then by moving the class at rates which do not allow sufficient time for students to become fully conversant. Another way this is done is to often leave the details to them to encounter in the assigned tasks, having shown the central and essential information only. For most students, temporary partial understanding is superseded by fuller understanding over time. One example involves the topic of continuous exponential growth. A partial, or perhaps unsatisfactory or fuzzy understanding of this concept is obtained. The example shows the convergence (which itself is a concept that may be poorly understood) of compound interest over increasingly smaller time periods to justify the use of the constant " e ":

Example 36.

If \$1000 was invested at 5% per annum over 10 years, calculate the amounts if interest was compounded for the following time periods: yearly, monthly, daily, every second and all the time (continuously)

The concept of compound interest itself is problematic. For some students, the Grade 12 unit on exponential and logarithmic functions is the first time they have been exposed to this concept. The purpose of this question is to show how compounding behaves over increasingly smaller time periods, and to connect it with a discussion of continuous exponential growth.

a) yearly: $1000(1.05)^{10} = \$1628.89$

b) monthly: $1000\left(1 + \frac{0.05}{12}\right)^{10 \times 12} = \1674.01

c) daily: $1000\left(1 + \frac{0.05}{365}\right)^{10 \times 365} = \1648.66

d) every second: $1000\left(1 + \frac{0.05}{365 \times 24 \times 60 \times 60}\right)^{10 \times 365 \times 24 \times 60 \times 60} = \1648.73

e) continuously: $1000e^{0.05 \times 10} = \1648.72

The concept of continuous exponential growth, and what the number “*e*” represents, contribute to this section of the course that is one that is both poorly and partially understood.

Partial understanding is intended to be a temporary condition enabling teaching and student learning to proceed. As a chronic condition, it is neither desirable nor acceptable. Determination of actual instances where partial understanding is an intentional outcome of teaching is difficult, as it depends on the individual student. Partial understanding, then, is not a goal, but an acceptable temporary condition. For some students it remains a permanent condition.

7. Structured Variation

Structured variation employs a series of related examples with strategic variations, with the intention of facilitating and reinforcing student learning through examining the similarities and differences in the example grouping. Watson and Mason

(2004) suggest that mathematical structure can be exposed by varying certain aspects of tasks while keeping others constant, and stress the use of systematic changes so that the learner does not overlook these variations. Further, Watson (2000) states, “Structural patterns emerge by looking across the examples, thus illuminating relationships and characteristics within the concept.” (p. 6). An introduction to logarithms is attempted through the use of a series of brief and simple examples. Initially, base 10 examples are used, moving to an exponential representation of the relationship. Those concepts are carried on to a different base:

Example 37.

- $\log 1000 = 3$
- $\log 10^6 = 6$
- $\log \sqrt{10} = \log 10^{\frac{1}{2}} = \frac{1}{2}$
- $\log \frac{1}{10} = -1$
- $\log 2 \approx 0.3010$ ($10^{0.3010} \approx 2$)
- $\log_3 81 = 4$ ($3^4 = 81$)

This series of examples is intended to illustrate these concepts in a self-evident manner.

The next example contains a set of transformations of the sine function.

Example 38.

Sketch the graphs of each of the following:

a) $y = 3 \sin \left[2 \left(x - \frac{\pi}{3} \right) \right] - 4$

b) $y = -2 \sin \left[\frac{2}{3} \left(x - \frac{\pi}{4} \right) \right]$

c) $y = \sin \pi x$

In these successive examples, the number of transformations applied to the basic function $y = \sin x$ decreases, while other aspects become more complex. The fundamental period 2π is varied in each case, moving from simple multiples of π in a), to 3π in b), and then to a numerical value of 2 units in part c). The order is intentionally skewed to allow attention to be drawn to these and other features, with the final example emphasizing a single characteristic. The example in a), having a vertical stretch by a factor of 3 (or amplitude of 3), vertical displacement of -4, horizontal compression by a factor of 2 and a horizontal translation (phase shift) of $\frac{\pi}{3}$, is also intended to create temporary overload, and a degree of partial understanding. I attempt to resolve these unstable conditions by the end of the third example.

8. To Overload

Overloading is the strategy of deliberately giving students too much information in too short a time. It may also consist of the assignment of tasks which are overly complex or lengthy, and/or not allowing sufficient time for the completion of tasks. The intention is to find an optimal mix of stress and strain so that students may come to an appreciation and understanding that they might not otherwise achieve. Of course, students may experience overload regardless of teacher intent, and my experience indicates that this strategy does not work for all students. It may be that the time and effort taken to re-teach, review, consolidate and level the class, as a consequence of

overload, does not result in a net gain for teacher and students. The following task is one that is intended to bring about some degree of overload:

Example 39.

For all special angles between 0° and 360° ,

- a) convert to radians (exact values),
- b) using basic principles, find the sine, cosine and tangent ratios (exact values) for each of these angles. Lay this out in a table.
- c) On one graph, plot each point from your table to graph the functions (on the domain from 0 to 2π) $y = \sin x$ and $y = \cos x$; on a separate graph, plot $y = \tan x$.

My intention is to maximize learning with a form of immersion into the characteristics of the graphs of trigonometric functions. Contributing to overload are the constituent tasks necessary to complete the task:

- Facility with special triangles special triangles (30° - 60° - 90° and 45° - 45° - 90°) and angles, and the determination of exact trigonometric values for special angles from 0 to 360 degrees (0 to 2π radians);
- Conversion of degree to radian measure and exact values of radian angle measure;
- Principles of graphing: setting up axes and scales and plotting points;
- Interpolation/extrapolation of the plotted points to obtain the graphs of the three functions, and discerning the asymptotic behaviour of the tangent function.

This task also points out the effect of early chronological placement of a problem in the learning cycle in contributing to overload. In this case, students are attempting to deal with new parameters (radian measure). If undertaken by students as intended, it serves several purposes simultaneously, while laying the groundwork that will play a key role

for the entire trigonometry section. The intention in creating an overloaded condition, and the stress that accompanies it, is to pressure students to come to terms with the level of content and the material itself. If successful, students are elevated to an appropriate level at which they are expected to perform.

9. To Prefamiliarize With Upcoming Topics

Across a mathematics curriculum, it is possible to provide clues and hints as to upcoming course content. By the time we get there, some of this content will have been anticipated. Most short-term future topics are logical extensions of previous work, and in this sense, prefamiliarization is an ongoing aspect of teaching. Longer-term prefamiliarization is less frequent, but any opportunity to promote student thinking in the direction of future topics is to our advantage. One way to accomplish pre-familiarization is to build minor digressions into worked examples whenever possible and appropriate. Instances of this seem difficult to capture, whether in lesson records or video recording. Blatant examples of this are classroom posters containing formulae for upcoming units – such as the expressions for permutations and combinations. The following example illustrates an attempt to embed an idea relevant to future work:

Example 40.

Given $f(x) = 2^x$, find the inverse, $f^{-1}(x)$

Placing this example prior to the study of logarithms means that students have no mechanism with which to extract “y” from the expression of the inverse, $x = 2^y$. At the

time this problem is given, students wrestle with the dilemma of how they might bring the exponent down. This will later provide an opportunity to introduce the logarithm, as well as to demonstrate that the logarithmic function is the inverse of the exponential.

The next “intention” considered, “create a platform for future scaffolding”, is similar to “prefamiliarization”. Both describe cases in which aspects of teaching are used to make future work and concepts more accessible to students. This is an expected characteristic of curriculum flow throughout school; these related “intentions” come into play when the expected condition proves inadequate to prepare students. This is discussed in the next section.

10. To Create a Platform for Future Scaffolding

Scaffolding is a term typically used to mean the provision of support in the metaphorical sense, to convey the idea of moving up through discrete levels of complexity. Henningsen and Stein (1997) use the term scaffolding to describe assistance that enables a student to complete a task, “but that does not reduce the overall complexity or cognitive demands of the task” (p. 527). I use the term in a slightly different sense, as in preparing students for upcoming work, either later in the current course or in future courses. Since the Grade 12 math course is a pre-calculus course, certain examples that lie slightly beyond curricular content can be used to emphasize algebraic and graphical representation of functions and relations that forms preparatory work in that direction:

Example 41.

Let f be the function given by $f(x) = \frac{|x|-2}{x-2}$

- a) Find all the zeros of f .
- b) Find the range of f .
- c) Graph $y = f(x)$.¹⁵

There are several aspects of this problem that are instructive.

- Piecewise functions;
- linking absolute value, roots of functions, domain and range and behaviour of functions;
- limits to $\pm\infty$ leading to determination of horizontal asymptotes;
- vertical asymptotes.

Insight gained by having taught the next level, which in the case of Grade 12 mathematics is calculus, facilitates the identification of necessary bridging topics. In this case, piecewise functions are identified as an overlooked topic, and thus can be addressed.

$$f(x) = \frac{|x|-2}{x-2} = \begin{cases} 1, & x \geq 0 \\ \frac{|x|-2}{x-2}, & x < 0 \end{cases}$$

Attending to these concepts allows us to pull a number of previously learned curricular topics from various locations in the high school curriculum together, and combine them in ways that are useful for future use. The topics used in the above example have more to do with the material in the Grade 11 mathematics course than the current course. This

¹⁵ Adapted from Advanced Placement Calculus 1991 Free Response Question.

provides another reason to “create a platform”, as pre-requisite knowledge students will need in the future recedes further into the past and is lost. Both “prefamiliarization” and “providing a platform for future scaffolding” can be used to emphasize for students those aspects of the high school mathematics curriculum deemed important and necessary for future mathematics and mathematics related courses.

11. Across The Grain

“Across the grain” is a metaphor used by Watson (2000) to describe student reflection on mathematics in a different manner than that which is used to generate the initial work. As Watson describes, “Awareness of structure appears to require reorganising one’s initial approach to a concept, by reflecting from another point of view” (p. 6). The detection of patterns, then, would be associated with “going with the grain”. I am using this metaphor in a slightly different sense, as a teaching strategy employed through examples that illustrate, reinforce and consolidate by using different or non-standard approaches. Such examples support our work in their corroboration of our results through different means. This can be quite powerful in the promotion of student’s understanding by cross-connecting existing examples to strengthen key points, as well as serving to enhance the larger canvas of overall mathematical understanding. An example which achieves “across the grain” success may well be the most productive use of an example from the teaching point of view. It combines other qualities including consolidation, extending, reviewing and others.

Although pedagogically among the best use of examples, they do not emerge frequently. It is perhaps no coincidence that my examples of across the grain unite graphical and algebraic approaches to functions. These large, disparate, under-connected yet essential strands in the high school pre-calculus curriculum are also often a source of cognitive dissonance, as discussed in the previous section. Each of the following examples was used to illustrate an alternative method to achieve a result.

Example 42.

Transform the graph $y = x^2$ into $y = 2x^2$.

The example may be construed as graphically, or to simply describe the transformation.

Typically, the transformation is considered as a vertical stretch, $y = af(x)$.

$y = 2x^2$ is graphed by vertically stretching $y = x^2$ by a factor of 2, since $a = 2$. Working across the grain, the same transformation can be considered as a horizontal compression, treating the function as $y = f(kx)$.

$$\begin{aligned}y &= 2x^2 \\ &= (\sqrt{2}x)^2\end{aligned}$$

Thus, the same transformation can be achieved with a horizontal compression by a factor of $\sqrt{2}$, since $k = \sqrt{2}$. Depending on the function, relationships can be found which obtain the same result through different transformations.

Example 43.

Sketch a graph of $y = \cos^2 x$ from basic principles.

One aspect of this example is the opportunity for an alternate demonstration of plotting this function by using the squares of the cosines of special angles. The results are interesting:

x	0	$\frac{\pi}{6}$	$\frac{\pi}{4}$	$\frac{\pi}{3}$	$\frac{\pi}{2}$	$\frac{2\pi}{3}$	$\frac{3\pi}{4}$	$\frac{5\pi}{6}$	π
$\cos x$	1	$\frac{\sqrt{3}}{2}$	$\frac{1}{\sqrt{2}}$	$\frac{1}{2}$	0	$-\frac{1}{2}$	$-\frac{1}{\sqrt{2}}$	$-\frac{\sqrt{3}}{2}$	1
$\cos^2 x$	1	$\frac{3}{4}$	$\frac{1}{2}$	$\frac{1}{4}$	0	$\frac{1}{4}$	$\frac{1}{2}$	$\frac{3}{4}$	1

Table 1: Special Angle Values for $\cos x$ and $\cos^2 x$

The graphs of $y = \cos x$ and $y = \cos^2 x$ are then produced as shown:

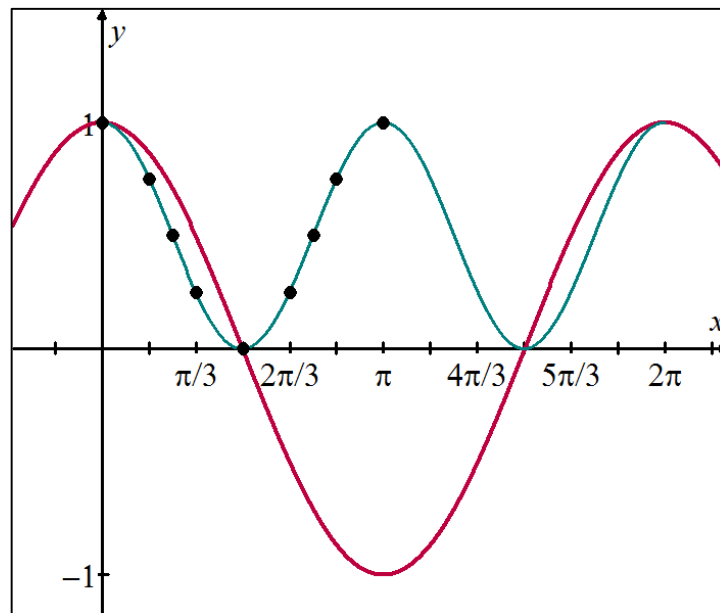

Figure 11: Graphs of $y = \cos x$ and $y = \cos^2 x$

The curve $y = \cos^2 x$ itself appears to be sinusoidal, (this may be confirmed with a graphing calculator, and is confirmed later in this example) with amplitude 0.5, central axis raised up 0.5 units, and a period π . Using this information, and our knowledge of the effects these transformations have on the cosine function equation:

$$y = a \cos kx + q \rightarrow \frac{1}{2} \cos 2x + \frac{1}{2}$$

Taking $\frac{1}{2} \cos 2x + \frac{1}{2}$ to be equal to $y = \cos^2 x$,

$$\cos^2 x = \frac{1}{2} \cos 2x + \frac{1}{2}$$

$$2 \cos^2 x = \cos 2x + 1$$

$$2 \cos^2 x - 1 = \cos 2x$$

Working across the grain, the double-angle identity for $\cos 2x$ has been confirmed by considering the transformation of $y = \cos x$ into $y = \cos^2 x$.

Example 44.

If an amount doubles in 8 days, express the growth as a function using e .

Students have difficulty distinguishing among the different ways in which exponential relationships may be expressed: as annual per cent growth, by a factor increase in a given duration as above, or as continuous growth using base e ; and that these ultimately represent the same thing. Our standard approach for “doubling” is to use base 2, but it is not typical to transform it:

$$y = y_0(2)^{\frac{t}{8}}$$

$$y = y_0(e^{\ln 2})^{\frac{t}{8}}$$

$$y = y_0e^{\left(\frac{\ln 2}{8}\right)t}$$

$$y = y_0e^{0.0866t}$$

A parallel approach shows the doubling relationship starting with the standard exponential growth equation, $y = y_0e^{kt}$

$$y = y_0e^{kt}$$

$$2 = (1)e^{k(8)}$$

$$\ln 2 = 8k$$

$$k = \frac{\ln 2}{8} \approx 0.0866$$

$$y = y_0e^{0.0866t}$$

Both approaches above yield the same result, and a further note is made that doubling every 8 days is equivalent to a continuous daily growth of about 8.7%. This across the grain approach links the various means to represent the same relationship. The final example demonstrates an indirect, yet common sense method of graphing logarithmic functions:

Example 45.

Graph $y = \log_2 x$

The purpose of working this example is to present an indirect method of accomplishing this task, while at the same time emphasizing the inverse relationship between the exponential and logarithmic functions. Starting with the more familiar function $y = 2^x$, it is relatively easy to produce ordered pairs: (0, 1), (1, 2), (2, 4), (3, 8), (-1, 0.5), (-2, 0.25), and so on. At this point in the course, students are not able to similarly

produce ordered pairs for the graph of the logarithmic function as easily. Since $y = \log_2 x$ is the inverse of $y = 2^x$, points on the logarithmic function are obtained by switching x and y values in the ordered pairs, and/or reflecting the points in the line $y = x$. Other graphical features of the logarithmic function, such as its asymptotic behaviour, are easily identified, as the asymptote line $y = 0$ for $y = 2^x$ becomes $x = 0$ for its inverse. We then confirm that the inverse of the exponential function is the logarithmic function:

$$\begin{aligned}f(x) &= y = 2^x \\x &= 2^y \\ \log_2 x &= y = f^{-1}(x)\end{aligned}$$

Whether or not students choose to use this simple indirect method, we have also demonstrated another algebraic-graphical connection through this across the grain example, and with it, continue to cement the concept of logarithms.

CHAPTER 6: CONCLUSIONS

1. Classification of Tasks and Examples

The complexity of teaching is well documented in the literature. Shulman's (1986) foundational distinction between the constituent theoretical aspects of teaching, subject matter content knowledge, pedagogical content knowledge and curricular knowledge, provide a basis for understanding this complexity. However, there remain problems in identifying and describing the "craft knowledge" of teaching (Leinhardt, 1990). Ball (2000) poses this pertinent question: "How could teachers develop a sense of the trajectory of a topic over time or how to develop its intellectual core in students' minds and capacities so that they eventually reach mature and compressed understandings and skills" (p. 246)? The answer is not simple. The ability of teachers to describe the inner workings of how they go about teaching is not well developed. Associated with the difficulty in articulating teaching processes is the lack of suitable language with which to do so.

The importance of the use of examples in mathematics classrooms is well accepted and documented in educational literature. The results of this study indicate many ways in which tasks and examples are employed. The origin, delivery and context categories describe the more obvious and easily discernable characteristics of task and example use, while the "intention" represents a deeper pedagogical purpose, and cannot necessarily be associated with a task or example. However, these intentions may be

realized through example use. These latter two categories, shown in Table 2, contain the sets of task and example types identified and more fully addressed in my study.

Context	Intention
<ul style="list-style-type: none"> • Standard • Overview • Warm-up • Introductory • Limiting • Contrasting • Review • Consolidating • Extending • Cross or Multi-Topic • Uncommon or Exceptional Case 	<ul style="list-style-type: none"> • Standard • To Level • To Create Cognitive Dissonance • To Stimulate Inquiry • To Create Partial Understanding • To Address Common Errors And Difficulties • Structured Variation • To Overload • To Pre-Familiarize With Upcoming Topics • To Create A Platform For Future Scaffolding • Across The Grain

Table 2: Classification of Examples and Tasks – Context and Intention

An important limitation to this categorization and classification breakdown is that there is an artificial sense that these constructs can exist independently. Many of the purposes of task and example use are highly intertwined with others, so that studying each in isolation is not entirely feasible. The two broad categories of context and intention overlap at several points; this is inevitable, as intention is descriptive of purpose, and context provides the means with which to achieve these intentions. As such, they are not always distinct. For instance, the following example was used to demonstrate the context of “extending” (see Example 19):

Determine the period and the amplitude of the function $y = k \sin \theta \cos \theta$.

This example is both an extending and cross/multi topic example in terms of its context, but also reflects intentions to simultaneously level, point out common difficulties and work across the grain. Such an example would also likely have consolidating and review “side effects”. In other cases, overview and introductory types of tasks and examples may be indistinguishable from each other, as they accomplish similar purposes. Review is an ongoing aspect in virtually all task and example deployment, and in many instances, is inseparable from “consolidation”. Further, as indicated previously, many of the contexts may be in action simultaneously, whether intended or not. To complicate matters, regardless of the teaching strategies and intentions, students will no doubt perceive and experience these examples and tasks in their own unique ways.

Christiansen and Walther (1986) caution:

We have repeatedly emphasized that the outcomes of an analysis, a classification, or an analysis of a task depend strongly on the pedagogical intentions under which the task is envisaged to be used in the class by the teacher or the didactician making the analysis. And similarly, that the students’ activity and learning – when and if the task is used in practice – depend strongly on the ways in which it is presented by the teacher and on his interactions with the learners in the class (p. 277).

The most frequent characteristics of the worked examples used in my lessons fall under the contextual umbrella of review and consolidation, with associated intentions of levelling, addressing common errors and difficulties, and working across the grain (wherever possible). These are reasonably standard uses, I believe, in mathematics classrooms. I have identified several other contexts and teaching intentions, which are indicative of less standard types of teaching strategies and approaches.

Overall, the various categories and subdivisions of task and example usage outlined in this study serve to deconstruct my craft knowledge relatively successfully,

and reasonably well describe what I attempt to accomplish in the Grade 12 mathematics classroom. In doing so, insights became available which were previously largely unattainable due to the nature of craft knowledge. In my case, this was an almost undecipherable collective of teaching strategies formulated over the years through direct experience, combined with an expert knowledge of the curricular material, (Shulman's "subject matter content knowledge"), also attained over time. Obviously, certain aspects of my use of tasks and examples were easier to describe and explain than others. Those aspects of my teaching that proved more elusive to identify and illustrate, such as teaching for partial understanding, and the creation of cognitive dissonance, have at least been identified and labelled. This provides a starting point for understanding these and other aspects of my teaching which have been difficult to extract from the craft. The analysis also provides a framework which may allow refinements, better descriptions and explanations to be formulated. This has three implications for my teaching, that of my colleagues in the profession, and perhaps those beginning a teaching career:

- The identification of the contexts and intentions inherent in my teaching affords a better awareness of the teaching and facilitates adjustment and improvement to my practice;
- I am more able to identify similar aspects in the practice of other teachers;
- The aspects of my teaching illuminated through this study provide useful insights for professional development for new and existing teachers.

2. Breach of Classroom Norms

By having multiple strategies operating simultaneously, the probability of achieving the curricular goals was increased. However, few of these intended teaching outcomes came to fruition when there was too poor of a fit between the demands of the course and the skill and knowledge levels of the students. This seems to be the dominant challenge that I have experienced in teaching Grade 12 mathematics – that students are ill-equipped to cope with the coursework, in spite of their many years of preparation. Many students are not ready for the tasks that await them in their senior high school mathematics courses. Addressing these shortcomings proves to be an important factor in how tasks and examples are used in the classroom. An example would be factoring by difference of squares, a Grade 9 or 10 topic, which has often not been successfully integrated into a mathematics repertoire by the time our students enter the Grade 12 course. I include poorly learned procedures and general lack of understanding of mathematical basics as contributing to this problem. For example, a surprising number of senior students could not explain why cross-multiplying works in the solution of simple fraction equations. I believe that this is symptomatic of a larger problem, a reliance on set algorithms and rote learning instead of understanding, even extending to the reduction of problem solving to memorizable procedures.

Given the teaching task of attaining a degree of mastery of the required curricular material to a level of sophistication appropriate to the grade level and the complexity of the subject matter, it is natural that certain teaching mechanisms evolved to facilitate the attainment of this goal. In part, this requires pushing students forward, and attempting to

find ways to speed up or to find viable short-cuts through the material for those experiencing difficulty. In this respect, my approaches may be described as contravening established classroom norms. Students expect classrooms to operate in a manner in which they have become accustomed to. As well, both students and teachers have been conditioned to act within certain institutionalized parameters and exhibit specific behaviours: teachers are expected to teach in specific ways and students to respond accordingly. These classroom norms include characteristics of most mathematics classrooms. Christiansen and Walther (1986) describe this as the “prevailing tradition”.

- The teacher specifies one or more exercises to be worked on by the pupils, usually in continuation of explanations and demonstration of procedure, which are linked to an example meant to serve as a model;
- The pupils learn from their work (individually or in groups) with the assignment, but their mathematical learning activity is predominantly limited to drill and practice in relation to previously described concepts and procedures;
- The results are controlled, and perhaps discussed with the whole class;
- If the teacher finds the feedback from the previous steps negative, he usually falls back to the standard procedure: further explanation – further drill; if he evaluates the feedback as positive, the pattern described is followed on ‘new’ exercises (p. 245).

These norms include predictable sequencing and chronological order of curriculum content, as well as the contrivances through which curriculum content is imparted as set up through textbooks, worksheets and exercises, and the predictable and periodic nature of assessment tools (tests, quizzes and exams). Bills et al (2006) discuss the typical use of exercises in teaching: “... having learned a procedure, the learner rehearses it on several such ‘exercise’ examples. This is first in order to assist retention of the procedure

by repetition, then later to develop fluency with it” (p. 1-136). Hildebrand (1999)

expressed this as the pedagogic contract¹⁶, and discusses the ramifications of breaking it:

Any time a teacher chooses to break the conventions, the prevailing norms, of the pre-existing pedagogic contract, they must expect student resistance and be prepared to justify why such a break is occurring. Just such a situation arises when teachers ask their students to move from a model of learning based on transmission to one based on constructivism (p. 3).

My teaching, in many instances, stretches and contravenes these classroom norms. Students generally have come to expect a relatively narrow range of pedagogical styles, which their teachers typically adhere to. Such styles often incorporate instructional note-taking and related predictable classroom procedures. My philosophy has been for students to learn by doing, and so note taking was replaced by worked examples. I developed an aversion to the process of note-giving, seeing this as anathemic from the student point of view, in spite of its inclusion in the pedagogic contract. I felt that student records of my worked examples would be superior to the act of note-taking, the distinction being that these “worked examples” would involve more than direct transcription of my work. It was vital that students be active participants in this process, working through these problems with me. Optimally, students would emerge with understanding as well as their own self-produced compilation of step-by-step annotated notes. Of course, this optimistic approach could never work for all of my students; in practice, this process often degenerated back to the simple note-taking which I had been attempting to avoid and improve on. The success of my approach is therefore highly dependent on student engagement.

¹⁶ Hildebrand (1999) re-labelled Brousseau’s (1997) didactic contract to clarify its meaning as that reflecting the context of a classroom or school culture, rather than the association of the term *didactic* with transmissive teaching.

Traditional teaching convention dictates that new concepts be introduced gradually, beginning with review of required knowledge, followed by a progression from simple to more complex material. This progression is typically characteristic not only of single classes and topics, but of entire units of content, and perhaps year-long course layout as well. Experience taught me when I could contravene this by beginning immediately with examples. For example, the following problem (see Example 10) was used to introduce the combinatorics unit, prior to teaching the constituent concepts:

Nine horses are in a race. How many different ways can they finish if two horses are tied?

It is true that this short-circuit does not work well with some students. This re-arrangement is not necessarily meant to accelerate course delivery. However, accelerated teaching in portions of the course does enable learning to occur for as long as possible. I would describe this as “maximal immersion.” The intention of such teaching is to increase the probability of all students reaching as far as they are able within the constraints imposed – available time, student ability level, etc.

Throughout high school, students have been accustomed to the tradition of unit tests as a closure to a specific package of curricular material. However, I found the analysis of these tests, after results are returned to students, to be an invaluable aspect of the learning process. Although these test items are intended to serve as an assessment of coursework mastery, they, more importantly from my point of view, if not the students, become part of the overall process of learning. Many students continue to improve mastery as they move through this post-test zone. It is always the case that some students experience maximal learning after error-correction and post-test consolidation.

3. Future Considerations

The complexity of example use at the senior high school level is not well reported. Existing studies examining teachers choices of examples are predominantly at the Grade 8 level and below. Although findings of such research are applicable across age groups, content knowledge requirements are more demanding in the final high school courses, and correspondingly, the pedagogical content knowledge that is tied to the teaching of senior secondary mathematics may be more demanding and complex. This might explain the fact that reported uses of tasks and examples do not reflect the much wider spectrum and depth of context and intention as set out in this report. Mathematical content in senior secondary courses moves past mathematics basics, so that those foundational and profound cases of teaching and learning, which are generally more easily observed in the early lessons of arithmetic and algebra, become more difficult to locate. In the senior high school mathematics class, it is also more difficult to isolate causes and effects in teaching and learning due to the complexity of content, and the divergence of students' mathematical abilities, skill sets and preparatory histories. Even through the middle high school Grades 8, 9 and 10, the tasks and examples are much simpler and less abstract, and therefore perhaps easier to analyze. Studies targeting elementary and middle school grades ultimately may be of limited relevance to the senior mathematics classroom. As well, senior secondary mathematics classes take on characteristics quite different from those of previous grades due to the obvious maturing of students. The final year in high school also serves as a transition period, preceding, or

as a prelude to post-secondary courses and programs, where students are likely to experience an entirely different pedagogical approach. I believe that there is an ingrained behaviour of teachers of senior secondary mathematics courses to build in preparatory aspects to prepare students for what lies ahead for them. I have indicated the use of “pre-familiarization with upcoming topics” as a teaching intention. This strategy applies in a larger sense, since, as teachers, we take every opportunity to prepare our students for life after high school in more than simply mathematics courses.

Further research is needed to continue the work on teachers’ uses of examples. The teaching and learning aspects are intertwined; this report focuses on the teacher perspective. Given this, it remained impossible to disconnect teacher actions from their impact on student learning. Studies point to the lack of teacher education in the use of examples; teachers gain expertise only through development of their craft. How teacher education programmes might make use of this expert teaching knowledge in assisting is an area warranting further study. As well, research clearly points to the difficulties teachers have in identifying, elucidating and communicating this expertise. Opportunities for professional development in this area would be useful for the teaching community.

The specific choice of examples may facilitate or impede students’ learning, thus it presents the teacher with a challenge, entailing many considerations that should be weighed. Yet, numerous mathematics teacher education programmes do not explicitly address this issue and do not systematically prepare prospective teachers to deal with the choice and use of instructional examples in an educated way. Thus, we suggest that the skills required for effective treatment of examples are crafted mostly through one’s own teaching experience (Zodik and Zaslavsky, 2008, p. 166).

The teaching use of tasks and examples is motivated and driven by factors which assist students in attaining mastery of the curricular material. The simplest and most

common use of examples is in “exemplification.” Peering beneath this obvious use, there are more complex functions served by the teaching use of tasks and examples. These uses arise, in part, from the necessity of taking steps to facilitate and expedite student learning and performance at a level consonant with that expected at the Grade 12 level. I interpret this “level” to include problem-solving. This is manifested by tasks and assessments which exceed the typical and expected types of questions and problems. This interpretation is also reflected in the underlying philosophy of the teaching process, which can be seen in the ways in which examples and tasks have been portrayed in this study. Whether or not the attainment of curricular objectives is to be measured by achievement on high-stakes examinations or not, aspects of these exams can be used to enhance classroom teaching. This is accomplished through the use of exam problems, as well as their tailored, altered, extended and adjusted forms. Inevitably, elements of final exams affect the manner in which course is taught. This is clear from the studies of the last thirty years. However, it need not detract from the quality of student learning.

APPENDIX

TRANSCRIPT 1¹⁷: Inverse of a logarithmic function

Find the inverse $f^{-1}(x)$ if $f(x) = 2\log_3(x+2)$:

Oh, I really threw you guys off by putting this 2 in front. So why would you make your life more difficult and put this 2 up here instead of just getting rid of it altogether and taking it to the other side? That's a tactical error. Because then you do the thing. Two ways to do this...

Okay, $y = 2\log_3(x+2)$, switch the x and y . You want to dig out this y . Don't make it worse! Make it better! Start getting rid of stuff. That's why you should get this 2 over here. And many of you put it up there. Yes, it's a law, I know, very good, yes, but not the best thing to do here. Yeah, I never did one of those, but I thought, let's put some transformation thing in there. Now I'll talk about the graph in a minute. So then we do that thing, there's two ways to do this I was just saying. Do you know what those two different ways are to get you the same thing? Do you? I think no. Do you have any idea what I'm talking about? It would be nice if you wrote something down. And now, here's the two things. What's it say, $\frac{x}{2} = \log_3(y+2)$. Okay, change this to exponential, what's the base? Where's the base? Is this the base? Is this the base? This? This? What is the log? What is the thing? The argument? We're one step away, just get this two to the other side and we're finished.

$$\frac{x}{2} = \log_3(y+2)$$

$$3^{\frac{x}{2}} = y+2$$

$$y = 3^{\frac{x}{2}} - 2$$

That's f -inverse of x . That's changing it from log to exponential. The other point of view is it's a log base 3, so do 3 to that equals 3 to that. What is 3 to this, well that's what it is. If I have 3 to the log base 3, it's $y+2$. Same.

¹⁷ Unless otherwise indicated, I am the speaker in this and the following transcripts.

$3^{\frac{x}{2}} = y + 2$. Same. Same result. Two different ways, same answer. So you should write $y = f^{-1}(x) = 3^{\frac{x}{2}} - 2$.

TRANSCRIPT 2: Transformation of the Sine Function into Cosine

If I move (the graph of) $\sin \theta$ 90° this way it becomes cosine θ . Correct? Then how do you do a movement 90° or $\frac{\pi}{2}$ that way? $\left[\theta + \frac{\pi}{2} \right]$.

$\cos \theta = \sin \left[\theta + \frac{\pi}{2} \right]$ That's just what I see from my graphs. Is this true? If I move the sine graph $\frac{\pi}{2}$ this way, it becomes the cosine graph. Have a look. Let's see if it works. Pick a θ . It should work – why do I have to check it? Is $\cos 0 = \sin \left[0 + \frac{\pi}{2} \right]$? What's the cosine of zero? [One].

What's the sine of $\frac{\pi}{2}$? One! Well, you need to start knowing these things. Tell me, sine of $\frac{\pi}{2}$, sine of 90° ? One! Cosine of zero? [1]. Well, it works for that angle. It actually works for everything, and in the next unit, the things that work all the time, we call them... identities, and that's an identity.

TRANSCRIPT 3: Formulation of a Trigonometric Equation

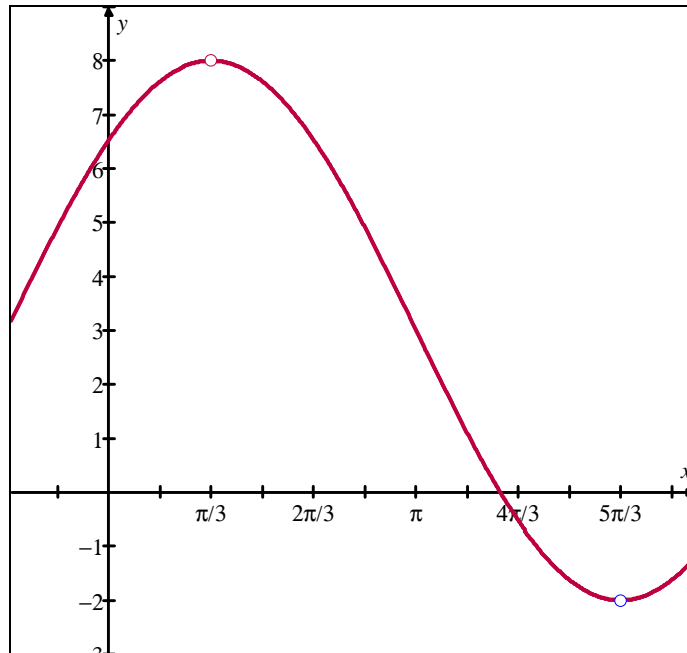

If I give you a point, ...a maximum point, and the thing will be, ...a maximum point is located at some x and some y , and the closest next minimum point to that is located at some coordinate. And I'll give you some numbers. ...Those are y coordinates. Right away you could tell me a few things. And let's say $\frac{\pi}{3}$ and $\frac{5\pi}{3}$. Just in case you're thinking about it,

that's 60° and that's 300° . Right? Because $\frac{\pi}{3}$'s are 60 's ...so as much as you can get used to radians, you should be trying to do that. Now you guys actually have an advantage because you will be thinking about radians longer than some other Math 12 classes, and you will be better able to work with it. So there is a bit of a method to the way I'm going with this. The question is, what is the equation of this graph? And you should say something to me right away. You should say aren't there more than one possible equation for that graph? Then my wording is not good. It should be, what is an equation or a possible equation, or... that might be more acceptable. What is an equation of this graph? Because if you've

been listening to me, sine and cosine are the same shaped graphs. It could be sine or cosine.

So let's find out everything we know about this graph just from these two points. Now I have to tell you that it is a ... – I don't know. How do I describe a graph that must be one of these waves? One word. Like, I'm not saying that this is a sine or cosine graph. A sinusoidal function means that it is a sine or a cosine. Well, let's see if it has to be a sine graph or not. (response to a student). I suggest to you that the easiest way to do this graph is to call it a cosine because when we graphed cosine we started at the top. Which is on the original of your graph, your y-axis. Cosine starts at the top. So your y-axis is over here. So how far, if it is a cosine graph, has it been shifted? It's right in front of you. This amount, from zero. So when you move a function this amount this way, how does it show up in the equation? You know from transformations $x - \frac{\pi}{3}$ shifts a graph $\frac{\pi}{3}$ units this way.

It's just a number, $\frac{\pi}{3}$, it's ah, well its 60° but as a number $\frac{\pi}{3}$ is 3.14 divided by 3 – it's just a number. But this is much nicer than using all those decimals. Now...can you tell me the amplitude of this? Isn't it that amplitude is up and down the same amount from a line in the middle that I call what? The central axis. ...Anyway, you should be able to give me the central axis. Shouldn't it be halfway between these two? How do you find halfway between two numbers? You add them, up and divide by 2. It's an average. What is it, 3? $y = 3$? Where is the central axis normally? Yeah, so how far are we up or down? If the phase shift is $\frac{\pi}{3}$ and I am dealing with a cosine... What's the amplitude? 5. So just do a check. Is it 5 and 5, 10 units from here to here? That looks like it, from 8 to -2. Just check. 5! I'm missing one thing. That's right. What is the period normally? One cycle is 2π . What's one cycle of this then? Question: How much of a cycle is it from the top to the bottom. Use your common sense. I'll come back when you have it. (I didn't go anywhere)...How much of a cycle? Half of a cycle! Let's try it again. How much of a cycle is it from the highest point to the next nearest lowest point? Half of a cycle! Doesn't matter if its sine or cosine. So between here and here is one-half of a - well, I used another word than cycle – the period. This half of a period. And there's nothing I've told you that isn't just almost pure common sense. If that's half of a period, what is one period? Well, I guess we need to know how far it is from here to here. I think the way you find distance is to subtract the lower one from the higher one. At least it worked when I was a kid. So what is half of a period? $\frac{4\pi}{3}$. How's the math there? So

one period is $\frac{8\pi}{3}$. Do you know anything about a period, like an equation, for example? $\text{Period} = \frac{2\pi}{k}$. So are we stretching the period or compressing it? It's not 2π . Wait a second. 2π is the normal period, $\frac{8\pi}{3}$, is that bigger? Yeah, because 2π is $6\frac{\pi}{3}$'s. This is bigger than normal. Anyway, there is a number in here that's called k and k is related to the period by this simple equation that I gave you. So what's k ? Maybe you have to do some figuring out here. Like $8\pi = 3$ times 2π . 8π times $k = 6\pi$. $k = \frac{6}{8}$ which is $\frac{3}{4}$ which is what you put in here:

$$y = 5 \cos \left[\frac{3}{4} \left(x - \frac{\pi}{3} \right) \right] + 3$$

TRANSCRIPT 4: Solving Trigonometric Equations With Exact Solutions

What is the solution to $\sin \theta = -\frac{1}{2}$, between zero and 360° , or (I am going to have to tell you), greater than zero and less than 2π , and you say, from your knowledge, $\theta = \frac{7\pi}{6}$ and $\frac{11\pi}{6}$, because you are so good at it. Can you rattle that off without doing any work?

Well, if you're not at that stage, then you have to step back, and you have to say, ah, I remember that this is special. What reference angle are we talking about, sine of that angle $-\frac{1}{2}$, and you need to know it's 30° and which quadrants have a negative sine, and you need to know that. These two. Do you know that? You need to know without thinking too much, and the reason I'd like you to say is that's where y is negative because sine is $\frac{y}{r}$.

So you have to know there is a 30° reference angle in this quadrant, and a 30° reference angle in this quadrant. But 30° is $\frac{\pi}{6}$, so this angle is $\frac{7\pi}{6}$,

$\frac{6\pi}{6}$ and one more, or you could go 1-2-3-4-5-6-7, 8-9-10-11, count the 30's, right?

Student: Also $\frac{12\pi}{6} - \frac{\pi}{6}$.

Okay, yes. What is logical and works... but the real thing is that this question comes up so much. What about this? $\sin \theta = +\frac{1}{2}$? It's these two. Now my diagram is all messy. Here, do some surgery. Well, 30° reference angle, so you have to know. You have to know these things, you have to spot them. This is $\frac{\pi}{6}$, well that's one of your answers. This is 1-2-3-4- $\frac{5\pi}{6}$, or $\frac{6\pi}{6}$ less one. So $\frac{\pi}{6}$ and $\frac{5\pi}{6}$.

This will come up actually more, even more in the second trig unit. Oh yes, very much.

...there is another way to do this. Well, now that you have a graphing calculator capability, except that this can be done by hand, what you are actually being asked is, "where is $\sin \theta$ equal to $\frac{1}{2}$?" Here and here. So what are these two angles? Well, this is $\frac{\pi}{6}$ and this is $\frac{5\pi}{6}$. so it could be done on a graphing calculator, but you'll get decimal answers. Still, though, that's what you're being asked, where is $\sin \theta$ equal $\frac{1}{2}$, but you should understand this representation.

TRANSCRIPT 5: Evaluating Sine and Cosine for 0°

That will be a question that many others of you will have. The special angles 0°, 90°, 180°, 270° and 360°, but really,... radians! $\frac{\pi}{2}$, π , this one, what's that? 270° ... you need to start knowing that. 270°, radians? 3 of

those, isn't it? 2π . You will have to think in radians. O.K., the special angles – they're not 30's, 60's, 45's. We looked at the 30's, 60's, 45's and all through your chart you should have seen a certain phenomenon and I'll just add one more: zero degrees. So we'll have our zero degree triangle, have a good look!

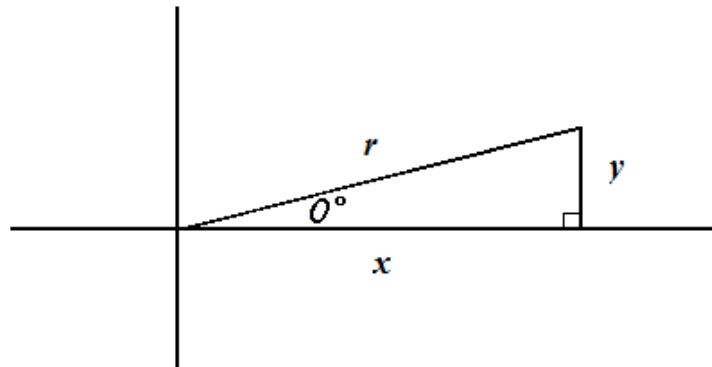

What do you think of it? It's impossible! But if it was zero degrees, how long would this be? Get it? This would be zero units long if that was really zero degrees. Are you with me? How long is this and this? Yeah, I don't know. They could be anything. But you're right, they're the same. But this is x and this is r and I know if you collapse this point here then r and x would be the same.

So, knowing that stuff, the sine of zero and the cosine of zero, and I've been talking about radians. This over this is the sine of the angle zero degrees, zero over anything is zero, the sine is ...

Student: Zero.

Cosine is this over this, but this is the same as this...

Student: One.

Tangent –

Student: Undefined.

...I don't think so, it's zero over something...

Student: Zero.

TRANSCRIPT 6: Sketching Trigonometric Functions

$$y = 3 \sin \left[1.5 \left(x + \frac{\pi}{3} \right) \right] + 1$$

Your job or our job is to sketch a graph of this thing, one complete cycle, at least one complete cycle. Sketch at least one complete cycle. I suggest graph paper or you are wasting your time. One complete cycle and label the important points. Now you might think it's up to you to decide which points are important, but whatever points you pick, I want to see those five. I want to see 1-2-3-4-5, the start of your cycle, the top of your cycle, back to the central axis, down to the minimum and back up to the central axis, for a sine graph. Those are the five I'm talking about.

So what are you going to do first? You figure out what's going on. The thing I'd like you to do the most is the period. What's the period? See this 1.5? I'd rather like to think of it as $\frac{3}{2}$. That right? So it equals $\frac{2\pi}{\left(\frac{3}{2}\right)}$. That

is $2\pi \times \frac{2}{3}$, which is $\frac{4\pi}{3}$. What's that in degrees?

Student: 240°.

It's 240°, yeah. If I were you, I'd be converting back and forth until I really...you may not have enough time to really get a handle on radians so your best bet is to work in conversions to degrees back and forth. But you can see that if this is 1.5, then the period should be divided by 1.5, so 2π ... seems about right, it's shorter than it should be normally. I wonder how we're going to deal with that. That is the length of one complete cycle. And what does this do? Amplitude is 3. So we did this and this. What does that do? That's the phase shift. Which direction? Yes, $\frac{\pi}{3}$ that way, which is left, the opposite of that. And this? Plus 1. Vertical up one. That's it. So. I have an x -axis. It's greenish. I probably will give you the axis so that I don't have 50 million versions of it. But I have to draw one complete cycle of it and one complete is $4\frac{\pi}{3}$'s. So I'm thinking of how I should do

my axis so that I can actually get those points on it because later I'm going to cut this period in quarters. I'm going to cut it in quarters so that I can do the thing I told you, so that I can go up-down-down-up in the quarters, but I need to start somewhere. So here is what I recommend:

One, do all that stuff we just did. I'd call that kind of an analysis. I looked at the four things. That, what does it do, that, what does it do, that, what does it do, and that, what does it do?

Secondly, find what I call the starting point, and here's what I mean. Assuming that someone gave you an axis, and you didn't have to worry about that. So, do an axis here. I wonder if I can make this $\frac{\pi}{3}$'s so this would be $\frac{\pi}{3}$, and that means one of these is $\frac{\pi}{6}$. So, $1\frac{\pi}{3}$, $2\frac{\pi}{3}$, $3\frac{\pi}{3}$, which is π , $4\frac{\pi}{3}$'s, 5 – I don't know if I need that. What do you think of my axis?

Does that look alright? $\frac{\pi}{3}$'s, I'm using $\frac{\pi}{3}$'s because I've got a $\frac{\pi}{3}$ phase shift and a $4\frac{\pi}{3}$ period. So we phase shift that way, and it's $\frac{\pi}{3}$, and then we go one up. $\frac{\pi}{3}$ and let's say that's one. Then 1-2-3-4, that would be two and 1-2-3-4, that would be negative one. So wouldn't it be nice if someone already did that for you? ...So the phase shift and the vertical displacement, phase shift that way, and 1 up, that is my starting point. Central axis was on the x -axis, we raise it up one so the central axis is now here. Are you with me? This is where I start my sine graph. It's going to start on the central axis and go up-down-down-up. But I may run into problem and you should have noticed. If I gave you this graph you could tell me the range right now without doing any work. It's up 1 but then from 1 its up 3 and down 3, the amplitude is 3, 3 times bigger than normal. Normal is 1. That means I'm going to go up to 4 and down to -2 . So the graph will look like that.

I don't think its going to fit. What should I do? It's going to go up to 4. My graph, I don't even get to 3. Should I adjust my vertical scale? Make it smaller? Well, I hope you can deal with that wrong central axis then. I don't want to waste another sheet. Anyone have white-out? So maybe I should make it 1, 2, 3, 4 so I know and 1,2,3 and -1 , -2 . We are going to be between these two points in the y –that's your range. So the central axis is now here, ignore this one. Now where's my starting point again, shifted $\frac{\pi}{3}$ that way, 1 up. Let's use blue. Here's my starting point. So have I done

what I said, find a starting point? This takes into account phase shift and vertical displacement. Now mark out one period from the starting point. What's the period? $\frac{4\pi}{3}$. Isn't it nice that my axis is in $\frac{\pi}{3}$'s? So from here, $1\frac{\pi}{3}$, 2, 3, 4. My graph will be in this box. Now, you don't have to draw a box, and this is the central axis of the graph. ...we start here. In the first quarter, we're up at the top, in the second quarter, we're back to the central axis, in the third quarter we're at the bottom and in the fourth quarter we finish. And you draw it. ...it doesn't stop! It actually keeps going, but I have drawn one cycle. I've taken into account the amplitude is 3 from the central axis, 1,2,3 up, 1,2,3, down, I did the phase shift. I did the compression by plotting one period. Cut it into four, first quarter, second quarter, third quarter, fourth quarter. Draw a nice sine graph. And now finish it. Sketch at least one complete cycle. Label coordinates of the important points. I should be able to read them off.

TRANSCRIPT 7: The Reciprocal of the Sine Function

We're going to use this now. We already have been. Sine, cosine and tangent. Sine and cosine: So what you got out of that thing is this: Sine. Y equals sine of what?

Student: Theta.

Theta. Then that means that this axis is theta. So do you know what it is you actually graph? You graph the function. If you start at zero, it goes to 2π (one cycle), but it actually keeps going. That's why my markers run out. It goes on forever, both directions. Good to know. So we're looking at a part of it. So this should be π , half. This should be half of that, and this should be half of that. So what are those, radians?

Student: Quadrants?

No, the x or theta coordinates. What are the angles? $\frac{\pi}{2}$, two of them, three of them, $\frac{3\pi}{2}$, alias 90° , 180° , 270° , 0° to 360° , and we can do more, but that'll be good enough for now. So way back in the mists of time, we did a

thing that looked like this. Let me see. $y = 0$, so one over zero becomes a vertical asymptote. What is that thing where we do one over every point? What is this y-coordinate? You should be well acquainted with that. What is it? You graphed it. No, what is that y-coordinate?

Student: Oh, one.

One. What is the reciprocal of one?

Student: One.

What is the reciprocal of negative one?

Student: Negative one.

I'm doing the reciprocal of $y = \text{sine of theta}$. Now, these values are being less than, well they are actually greater than negative one, but they're getting smaller. When you do the reciprocal, what happens to these points? Will they start going down here? Will it? And up here? This, let's say at $\frac{\pi}{4}$. What is this y coordinate? Sine of $\frac{\pi}{4}$, you should know it.

Really you should. The sine of 45° is what I'm asking you, the sine of $\frac{\pi}{4}$. You need to know it.

Student: $\frac{1}{\sqrt{2}}$.

You need to know instantly. $\sin \frac{\pi}{6}$, $\sin \frac{\pi}{4}$, oh, I know, I took your tables away. $\sin \frac{\pi}{3}$, $\sin \frac{\pi}{2}$, $\sin 0$. That's asking you for the sine of 30° , that's asking you for the sine of zero, zero. Sine of 30° , $\frac{1}{2}$, sine of 45° , $\frac{1}{\sqrt{2}}$, sine of, well, you do that, what's sine of 60° , or $\frac{\pi}{3}$?

...anyway, you have to unify this graph with these ideas. So what was I asking before I went off on this thing is what is the sine of 45° ? $\frac{1}{\sqrt{2}}$.

When you graphed it, what was the decimal? 0.707, $\frac{1}{\sqrt{2}}$, 0.707. Anyway, this is $\frac{1}{\sqrt{2}}$. That's the sine of 45° . What's the reciprocal of $\frac{1}{\sqrt{2}}$? $\sqrt{2}$! Isn't that nice – which is approximately 1.414. So it's up here. So what

I'm getting at is since you've already done reciprocals, the reciprocal of sine theta end up looking like – it's there, and you have one of those other arches here. This is also an asymptote, right? And gets there, and goes up. And everytime it repeats itself, you'll get a repeat of this arch here, and this arch here, and we have a name for this function. The name for that, the reciprocal of sine. So we are doing $\frac{1}{\sin \theta}$ is called cosecant θ . Well, short form for cosecant - csc - cosecant, reciprocal of sine. So I could leave off the $y =$, we have one over cosine called secant, and we have one over tangent called cotangent. So now there's six: sine, cosine, tangent, cosecant, secant, cotangent.

So the cosecant of $\frac{\pi}{6}$ is one over the sine of $\frac{\pi}{6}$, and the sine of $\frac{\pi}{6}$ is the sine of 30° is $\frac{1}{2}$. So the cosecant of $\frac{\pi}{6}$ is one over one over two which is 2.

...What is the range of $y = \sin \theta$? What's range? Verticalness. Y is greater than -1 but less than $+1$. It's between -1 and $+1$. What is the range of its reciprocal, the $y = \csc \theta$, of which we've drawn, at least one little bit of it. You guys with graphing calculators, you could graph it, you could just graph $y = \frac{1}{\sin x}$. What's stopping you? Good thing I'm not asking you for the domain. That would be trouble. Wow. I guess we have to talk about it now. But what is the range of $y = \csc \theta$, which I've drawn here? Range of cosecant, well its everything below there and everything above there, right? This is no-man's land. Favourite question on tests. The answer is, y is less than or equal to -1 or y is greater or equal to $+1$. That should do it. Isn't it interesting?

The domain: What is the domain of $\sin x$? Yes, it's all, it's everything. All real numbers. Domain of $y = \sin x$ and therefore also $\cos x$, but not tangent of x because tangent has asymptotes. I hope you saw it when you graphed it. x is all real numbers, $x \in R$, so that's the lingo. Or you just say all real numbers, or you could say all reals. The domain of it's reciprocal, the domain of $y = \csc \theta$ - I'm switching between x and θ . I hope that's okay. It's still an angle on this axis. Well, every so often we have an asymptote. Well, every how often? Every π we have an asymptote. How can I say that forever? Well, we have this interesting way of going forever. It's actually kind of simple. Domain of cosecant is x is all real numbers...but not - because it has a few exceptions. The asymptotes are places where the domain doesn't exist. But everywhere else than these dotted lines, and it's every π , so why don't we call it "n" times π , where n is an integer, or you say where n is any integer, because that takes care of all positive and negative multiples of π .

What do you think? And the short form of that would be n is an integer, $n \in I$. And in other countries than Canada, they use Z for the set of integers, so we accept that. We use I , because I for integer. Anyone seen Z ?

So, this is a concept going to infinity, plus and negative. So this tells you that every integer multiple of π you have a vertical asymptote, can't be part of the domain. What do you think? We'll use it next unit.

So what is the domain of one of it's cousins? Secant, ...just let me say if cosine is only this graph moved 90° this way so that this point goes here, then shouldn't it's reciprocal just be moved also?

...So what is important is cosine is sine, same graph, just shifted, and so it's reciprocal looks like that. So the ranges and domains, sorry the ranges are the same. ...The ranges of sine and cosine are the same, so the ranges of the reciprocals are the same. If anyone ever asks you, and I will, the domain though: It's at $\frac{\pi}{2}$ or 90° where you have these vertical asymptotes

now because those are the roots of cosine. So n times $\frac{\pi}{2}$... I don't know

because if you do n is an integer times $\frac{\pi}{2}$ that means I'll have... and I don't want all those. I only want this one and then this one. So like I want one $\frac{\pi}{2}$ and $\frac{3\pi}{2}$. I think the next one will be $\frac{5\pi}{2}$. So I have to find a way to do that.

REFERENCE LIST

- Arcavi, A. (2003). The role of visual representations in the learning of mathematics. *Educational Studies in Mathematics*, 52, 215-241.
- Atkinson, R.K., Derry, S.J., Renkl, A., & Wortham, D. (2000). Learning from examples: Instructional principles from the worked examples research. *Review of Educational Research*, 70(2), 181-214.
- Ayres, P., Sawyer, W. & Dinham, S. (2004). Effective Teaching in the Context of a Grade 12 *High-Stakes* External Examination in New South Wales, Australia. *British Educational Research Journal*, 30(1) 141-165.
- Ball, D.L. (2000). Bridging practices: Intertwining content and pedagogy in teaching and learning to teach. *Journal of Teacher Education*, 51, 241-247.
- Bills, L., Dreyfus, T., Mason, J., Tsamir, P., Watson, A., & Zaslavsky, O. (2006). Exemplification in mathematics education. Proceedings of the 30th Conference of the International Group for the Psychology of Mathematics Education, 1, 126-154.
- Boaler, J. (2002), *Experiencing school mathematics: Traditional and reform approaches to teaching and their impact on student learning*. Mahwah, New Jersey: Lawrence Erlbaum Associates.
- Bohicchio, D., Cole, S., Ostien, B., Rodrigues, V., Staples, M., Susla, P., & Truxaw, M. (2009). Shared language. *Mathematics Teacher*, 102(8), 605-613.
- Brousseau, G. (1997), *Theory of Didactical Situations in Mathematics: Didactique des mathematiques, 1970-1990*. (translated by N. Balacheff). Hingham, MA: Kluwer.
- Carpenter, T. P. (1988). Teaching as problem solving. In R. Charles and E. Silver (Eds.), *The teaching and assessing of mathematical problem solving* (pp. 187-202). Reston, VA: National Council of Teachers of Mathematics.
- Charmaz, K. (2000). Grounded theory: Objectivist and constructivist methods. In N. Denzin & Y. Lincoln (Eds.), *The handbook of qualitative research* (2nd ed.) (pp. 509-535). Thousand Oaks, CA: Sage.
- Christiansen, B., & Walther, G. (1986). Task and Activity. In B. Christiansen, A. Howson, & M. Otte (Eds.), *Perspectives on mathematics education* (pp. 243-307). Hingham, MA: Kluwer.

- Cresswell, J. W. (2008). *Educational research: planning, conducting, and evaluating quantitative and qualitative research* (3rd ed.). Upper Saddle River, NJ: Pearson Education.
- Ellis, C. & Bochner, A. (2000). Autoethnography, personal narrative, reflexivity: Researcher as subject. In N. Denzin & Y. Lincoln (Eds.), *The handbook of qualitative research* (2nd ed.) (p. 733-768). Thousand Oaks, CA: Sage.
- Fan, L. & Zhu, Y. (2007). Representation of Problem-Solving Procedures: A comparative look at China, Singapore, and US mathematics textbooks. *Educational Studies in Mathematics*, 66(1), 61-75.
- Festinger, L. (1957). *A theory of cognitive dissonance*. Stanford: Stanford University Press.
- Goldenberg, P. & Mason, J. (2008). Shedding light on and with example spaces. *Educational Studies in Mathematics*. 69, 183-194.
- Guskey, T. R. (2007). Multiple sources of evidence: An analysis of stakeholders' perceptions of various indicators of student learning. *Educational Measurement: Issues and Practice*, 26(1), 19-27.
- Hewitt, D. (1996). Mathematical fluency: The nature of practice and the role of subordination. *For the Learning of Mathematics*, 16 (2), 28-35.
- Hiebert, J., Gallimore, R., Garnier, H., Bogard Givvin, K., Hollingsworth, H., Jacobs, J., Angel Miu-Ying Chui, Wearne, D., Smith, M., Kersting, N., Manaster, A., Tseng, E., Etterbeek, W., Manaster, C., Gonzales, P., & Stigler, J. (2003). *Teaching Mathematics in Seven Countries: Results From the TIMSS 1999 Video Study*, U.S. Department of Education, National Center for Education Statistics. Washington, DC.
- Hildebrand, G. (1999). Con/testing learning models. Paper presented at the Australian Association for Research in Education & New Zealand Association for Research in Education Conference, Melbourne.
- Kirschner, P. A. (2002). Cognitive load theory: Implications of cognitive load theory on the design of learning. *Learning and Instruction* 12 (1-10).
- Koretz, D. M. (2002). Limitations in the use of achievement tests as measures of educator's productivity. *The Journal of Human Resources*, 37(4). 752-777.
- Krainer, K. (1993). Powerful Tasks: A Contribution to a High Level of Acting and Reflecting in Mathematics Instruction. *Educational Studies in Mathematics*, 24(1), 65-93.
- Kraus, S., Brunner, M., Kunter, M., Baumert, J., Blum, W., Neubrand, M., & Jordan, A. (2008). Pedagogical content knowledge and content knowledge of secondary mathematics teachers. *Journal of Educational Psychology*, 100(3), 716-725.

- Lave, J., Smith, S., & Butler, M. (1988). Problem solving as everyday practice. In R. Charles and E. Silver (Eds.), *The teaching and assessing of mathematical problem solving* (pp. 61-81). Reston, VA: National Council of Teachers of Mathematics.
- Leinhardt, G. (1990). Capturing Craft Knowledge in teaching. *Educational Researcher*, 19(2), 18-25.
- Leinhardt, G., Zaslavsky, O., & Stein, M. K. (1990). Graphs and graphing: Tasks, learning and teaching. *American Educational Research Association*, 60(1), 1-64.
- Leung, S. (1997). On the open-ended nature in mathematical problem posing. In E. Pehkonen (Ed.), *Use of open-ended problems in mathematics classroom* (pp. 26-33). Research Report 176, University of Helsinki.
- Madaus, G. F. (1988). The distortion of teaching and testing: High stakes testing and instruction, *Peabody Journal of Education*, 65(3), 29-46.
- Mason, J. (2002). What makes an example exemplary: Pedagogical and research issues in transitions from numbers to number theory. In A. D. Cockburn & E. Nardi (Eds.), *Proceedings of the 26th international conference for psychology of mathematics education*, v. 1, (pp. 224–229). Norwich, UK.
- Mason, J. (2006). What makes an example exemplary: Pedagogical and didactical issues in appreciating multiplicative structures. In R. Zazkis, & S. R. Campbell (Eds.), *Number theory in mathematics education: Perspectives and prospects* (pp. 41–68). Hillsdale, NJ: Erlbaum.
- Measuring and Improving the Effectiveness of High School Teachers. Issue brief, March 2008, Alliance for Excellent Education.
- Mehrens, W. A. (1991). Defensible/indefensible instructional preparation for high stakes achievement: An exploratory dialogue. Revision of a paper presented at the Annual Meetings of the American Educational Research Association (Chicago, IL, April 3-7, 1991) and the National Council on Measurement in Education (Chicago, IL, April 4-6, 1991).
- Rissland, E. L. (1978). Understanding understanding mathematics. *Cognitive Science*, 2(4), 361–383.
- National Council of Teachers of Mathematics (NCTM) (2000). *Principles and standards for school mathematics*. Reston: NCTM.
- Pehkonen, E. (1997). Introduction to the concept of “open-ended” problem. In E. Pehkonen (Ed.), *Use of open-ended problems in mathematics classroom* (pp. 7-11). Research Report 176, University of Helsinki.
- Popham, W. James, Instructional Insensitivity of Tests: Accountability’s Dire Drawback. *Phi Delta Kappan*, Oct. 2007, 146-155.
- Popham, W. (2001). Teaching to the test? *Educational Leadership*, 58(6), 16-20.

- Rowland, T. (2008). The Purpose, Design and Use of Examples in the Teaching of Elementary Mathematics. *Educational Studies in Mathematics*, 69(2), 149-163.
- Shavelson, R., Webb, N., Stasz, C., & McArthur, D. (1988). Teaching mathematical problem solving: Insights from teachers and tutors. In R. Charles and E. Silver (Eds.), *The teaching and assessing of mathematical problem solving* (pp. 203-231). Reston, VA: National Council of Teachers of Mathematics.
- Schoenfeld, A. (1992). Learning to think mathematically: Problem solving, metacognition, and sense making in mathematics. In D. Grouws (Ed.), *Handbook for Research on Mathematics Teaching and Learning* (pp. 334-370). New York: MacMillan.
- Schoenfeld, A. (1988). When good teaching leads to bad results: the disasters of “well taught” mathematics courses. *Educational Psychologist*, 23(2), 145-166.
- Shulman, L. S. (1986). Those who understand: knowledge growth in teaching. *American Educator*, 10(1), 4-14.
- Stake, R. E. (2000). Case Studies. In N. Denzin & Y. Lincoln (Eds.), *The handbook of qualitative research* (2nd ed.) (pp. 435-454). Thousand Oaks, CA: Sage.
- Stanic, G. & Kilpatrick, J. (1988). Historical perspectives on problem solving in the mathematics curriculum. In R. Charles and E. Silver (Eds.), *The teaching and assessing of mathematical problem solving* (pp. 1-22). Reston, VA: National Council of Teachers of Mathematics.
- Stein, M.K., Grover, B.W., & Henningsen, M. (1996). Building student capacity for mathematical thinking and reasoning: An analysis of mathematical tasks used in reform classrooms. *American Educational Research Journal*, 33(2), 455-488.
- Sweller, J. & Low, R. (1992). Some cognitive factors relevant to mathematics instruction. *Mathematics Education Research Journal*, 4(1), 83-94.
- Volante, L. (2006). Toward appropriate preparation for standardized achievement testing. *The Journal of Educational Thought*, 40(2), 129-144.
- Watson, A. (2000). Going across the grain: Generalisation in a group of low attainers. *Nordisk Matematikk Didaktikk (Nordic Studies in Mathematics Education)*. 8(1) 7-22.
- Watson, A. & Mason, J. (2004). The exercise as mathematical object: Dimensions of possible variation in practice. *Proceedings of the British Society for Research into Learning Mathematics*. 24(2), 107-112.
- Watson, A. & Mason, J. (2007). Taken as shared: A review of common assumptions about mathematical tasks in teacher education. *Journal of Mathematics Teacher Education*. 10, 205-215.
- Zazkis, R., Liljedahl, P., & Sinclair, N., (2010). Shifts of attention in prospective teachers' images of teaching. Unpublished manuscript.

- Zaslavsky, O., (2010). The explanatory power of examples in mathematics: Challenges for teaching. In M. K. Stein and L. Kucan (Eds.), *Instructional explanations in the disciplines* (pp. 107-128). Springer US.
- Zodik, I. & Zaslavsky, O. (2008). Characteristics of teachers' choice of examples in and for the mathematics classroom. *Educational Studies in Mathematics*. 69, 165-182.
- Zodik, I. & Zaslavsky, O. (2009). Teachers' treatment of examples as learning opportunities. In Tzekaki, M., Kaldrimidou, M. & Sakonidis, H. (Eds.). *Proceedings of the 33rd Conference of the International Group for the Psychology of Mathematics Education*, 1, 425-432.