



US007566508B2

(12) **United States Patent**
Thangaraj et al.

(10) **Patent No.:** **US 7,566,508 B2**

(45) **Date of Patent:** **Jul. 28, 2009**

(54) **PERPENDICULAR MEDIA WITH CR-DOPED
FE-ALLOY-CONTAINING SOFT
UNDERLAYER (SUL) FOR IMPROVED
CORROSION PERFORMANCE**

(58) **Field of Classification Search** None
See application file for complete search history.

(56) **References Cited**

U.S. PATENT DOCUMENTS

6,172,859	B1 *	1/2001	Watanabe et al.	360/327.3
6,599,376	B2 *	7/2003	Morikawa et al.	148/306
7,083,870	B2 *	8/2006	Shimizu et al.	428/828
7,361,419	B2 *	4/2008	Uwazumi et al.	428/831.1

(75) Inventors: **Raj Nagappan Thangaraj**, Fremont, CA (US); **Mariana Rodica Munteanu**, Santa Clara, CA (US); **Erol Girt**, Berkeley, CA (US); **Michael Joseph Stirniman**, Fremont, CA (US)

OTHER PUBLICATIONS

(73) Assignee: **Seagate Technology LLC**, Scotts Valley, CA (US)

English abstract of JP 57-192246.*

(*) Notice: Subject to any disclaimer, the term of this patent is extended or adjusted under 35 U.S.C. 154(b) by 351 days.

* cited by examiner

Primary Examiner—Holly Rickman

(74) *Attorney, Agent, or Firm*—Shumaker & Sieffert, P.A.

(21) Appl. No.: **11/068,898**

(57) **ABSTRACT**

(22) Filed: **Mar. 2, 2005**

A perpendicular magnetic recording medium having a substrate, a Cr-doped Fe-alloy-containing underlayer containing about 8 to 18 at % Cr and a perpendicular recording magnetic layer, and a process for improving corrosion resistance of the recording medium and for manufacturing the recording medium are disclosed.

(65) **Prior Publication Data**

US 2006/0199044 A1 Sep. 7, 2006

(51) **Int. Cl.**
G11B 5/66 (2006.01)

(52) **U.S. Cl.** 428/832

11 Claims, 6 Drawing Sheets

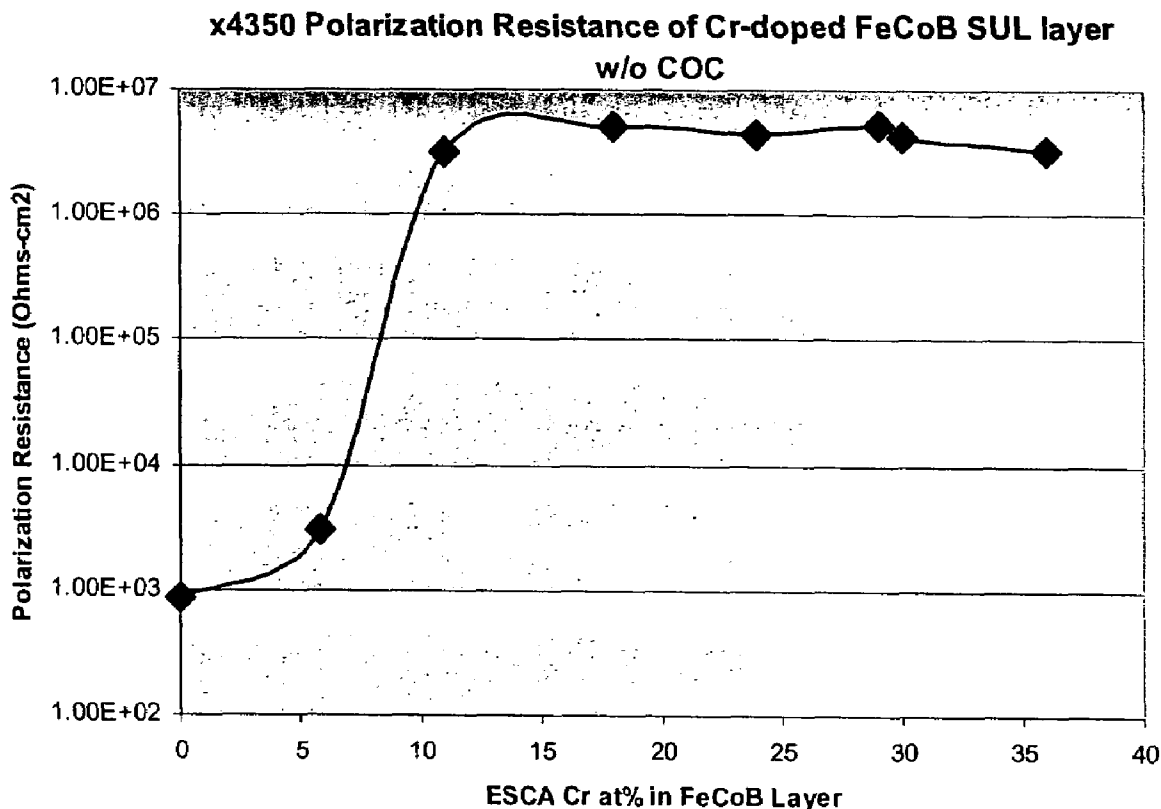

Figure 1

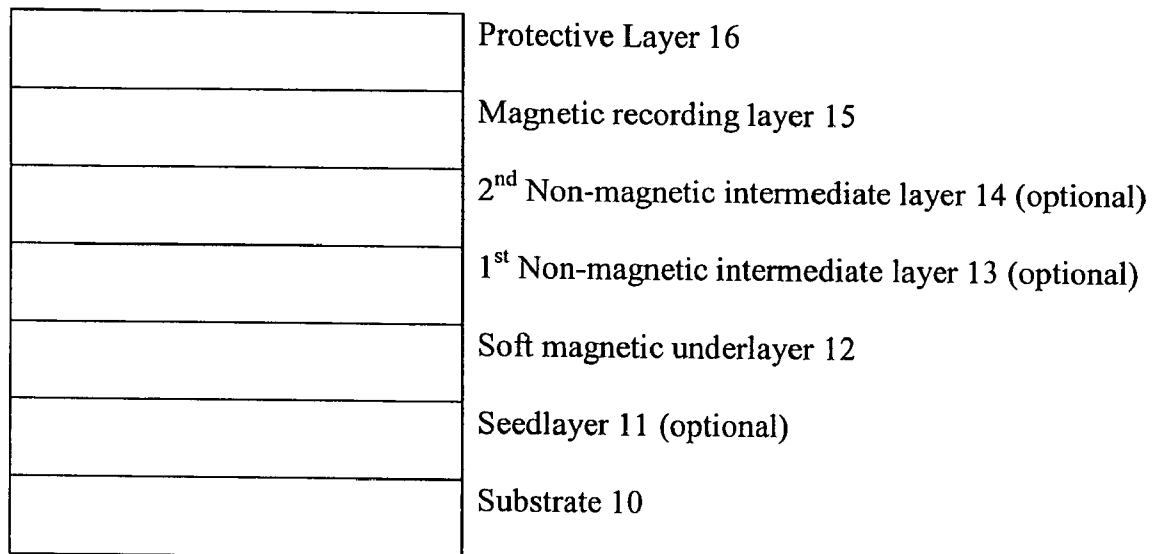

Figure 2

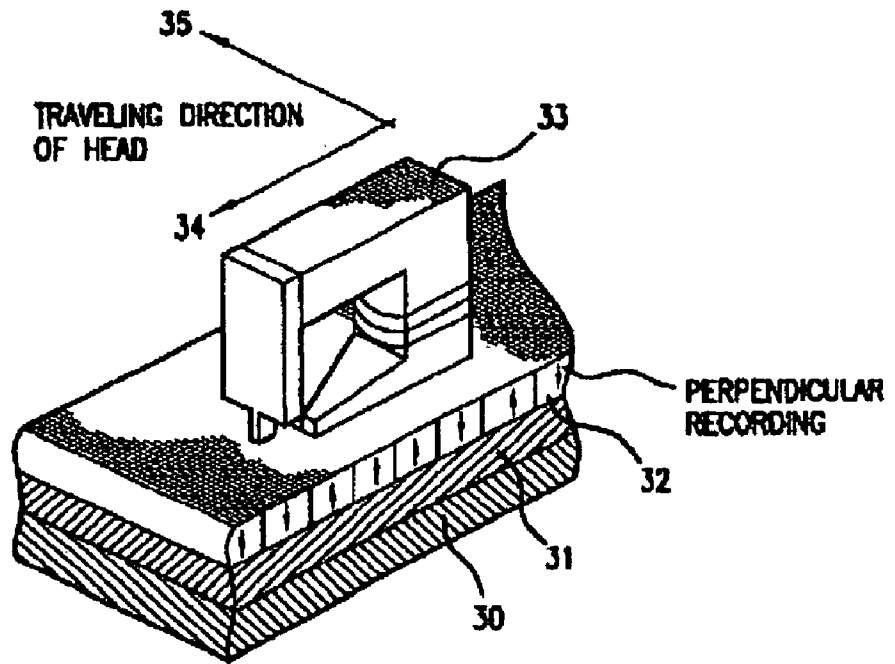

Figure 3

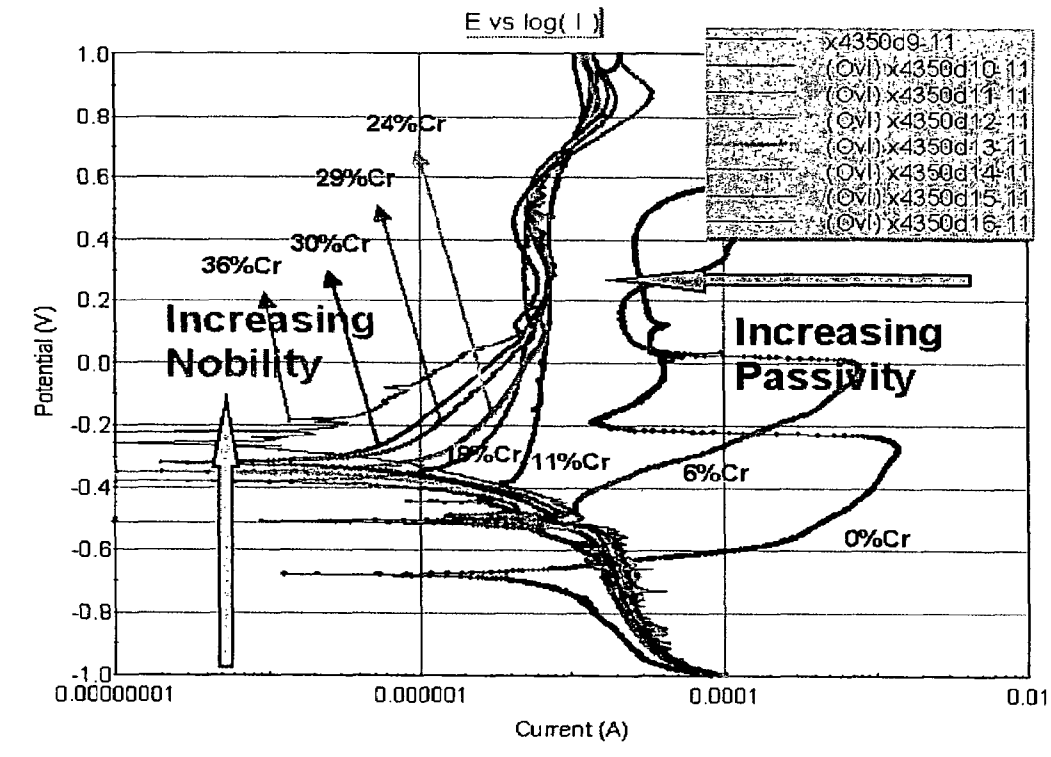

Figure 4

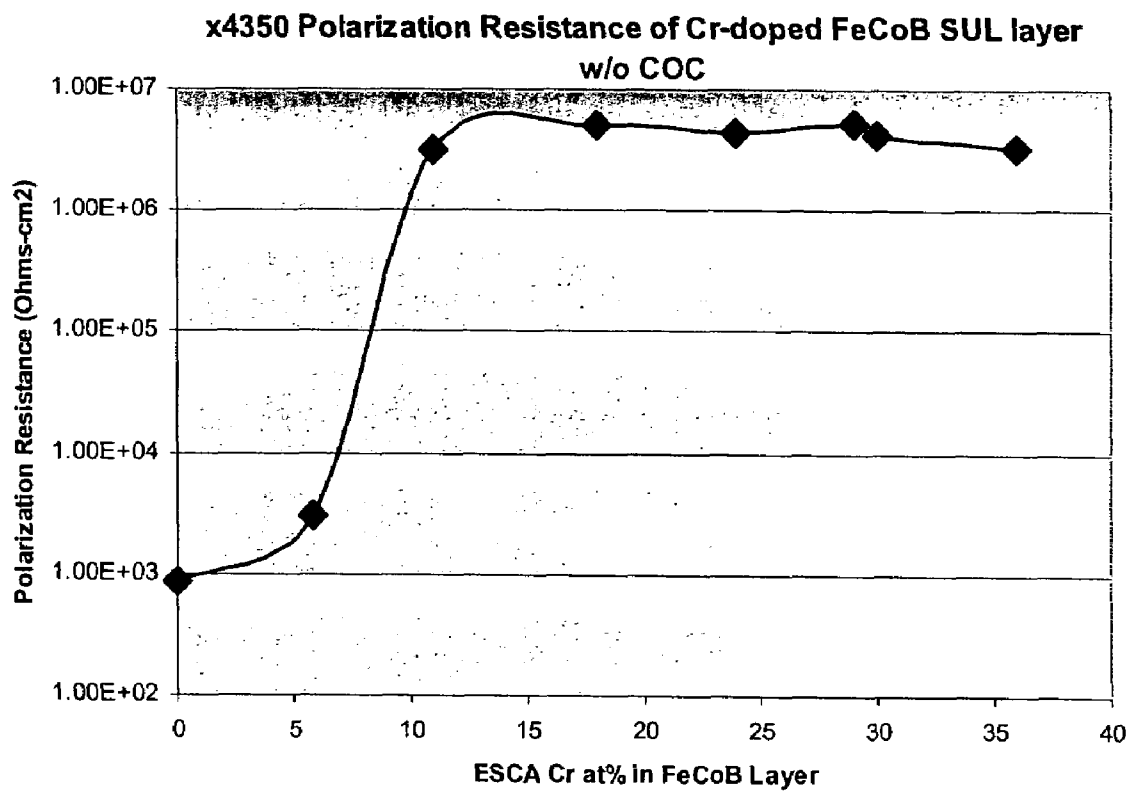

Figure 5

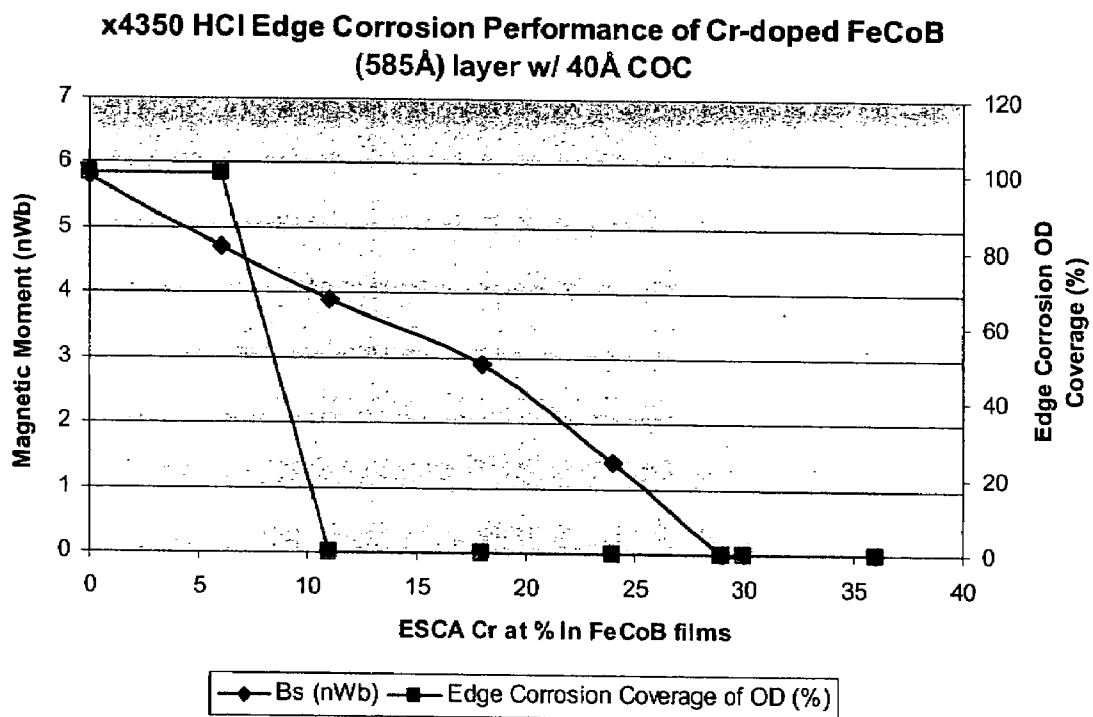

Figure 6a

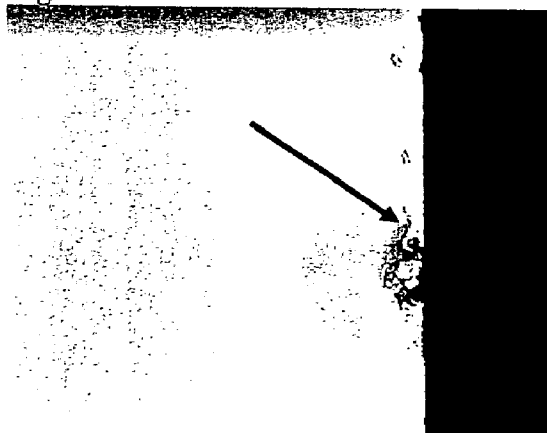

Figure 6b

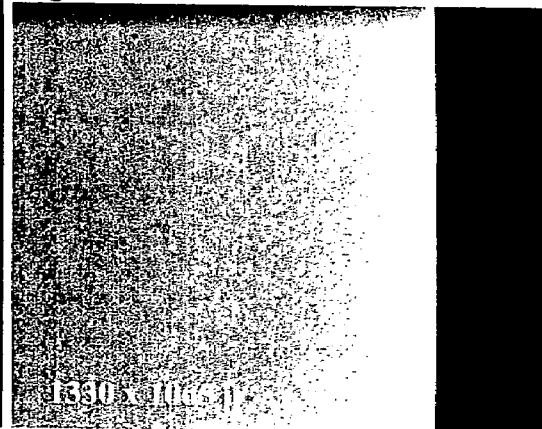

Figure 6c

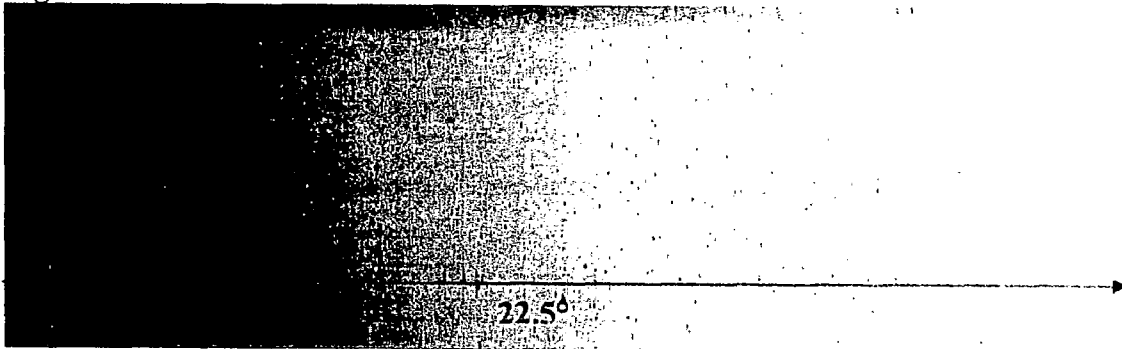
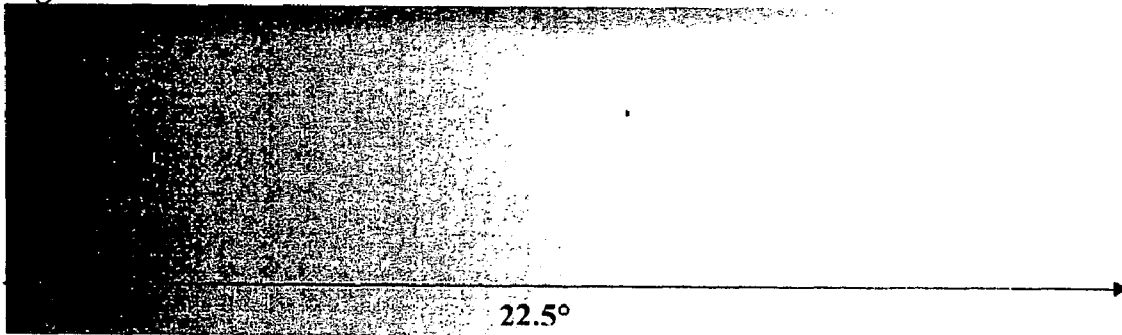

Figure 6d



**PERPENDICULAR MEDIA WITH CR-DOPED
FE-ALLOY-CONTAINING SOFT
UNDERLAYER (SUL) FOR IMPROVED
CORROSION PERFORMANCE**

FIELD OF INVENTION

This invention relates to perpendicular recording media, such as thin film magnetic recording disks having perpendicular recording, and to a method of manufacturing the media. The invention has particular applicability to perpendicular media having Cr-doped FeCoB soft underlayer (SUL) for improved corrosion resistance, high areal density magnetic recording media exhibiting low noise.

BACKGROUND

A magnetic material is composed of a number of domains. Each domain contains parallel atomic moments and is magnetized to saturation, but the directions of magnetization of different domains are not necessarily parallel. Local preferred directions of magnetization depend upon the underlying microscopic structure of the material. Magnetic recording media microstructure generally includes grains or particles comprising regions of constant crystal structure or geometry. The local directions of easiest magnetization depend upon the geometry of the crystals. In the absence of an applied magnetic field, adjacent domains may be oriented in different directions, controlled by the underlying grain structure. The resultant effect of all these various directions of magnetization may be zero, as is the case with an unmagnetized specimen. When a magnetic field is applied, domains nearly parallel to the direction of the applied field become more prevalent at the expense of the others. A further increase in magnetic field causes more domains to rotate and align parallel to the applied field. When the material reaches the point of saturation magnetization, all domains are parallel to the applied field and no further domain growth or rotation would take place on increasing the strength of the magnetic field.

The ease of magnetization or demagnetization of a magnetic material depends on material parameters including composition, crystal structure, grain orientation, and the state of strain. The magnetization is most easily obtained along the easy axis of magnetization but most difficult along the hard axis of magnetization. A magnetic material is said to possess a magnetic anisotropy when easy and hard axes exist. On the other hand, a magnetic material is said to be isotropic when there are no easy or hard axes.

In a perpendicular recording media, magnetization is formed easily in a direction perpendicular to the surface of a magnetic medium, typically a magnetic recording layer on a suitable substrate, resulting from perpendicular anisotropy in the magnetic recording layer. On the other hand, in a longitudinal recording media, magnetization is formed in a direction in a plane parallel to the surface of the magnetic recording layer, resulting from longitudinal anisotropy in the magnetic recording layer.

Thin-film magnetic recording media require small exchange decoupled magnetic particles. Decoupling is commonly achieved by having a non-ferromagnetic material between the ferromagnetic particles. This non magnetic region has been formed in the prior art by films having a higher percent composition of either chromium, boron, or an oxide material at the boundaries between magnetic particles than within the magnetic particles. Separation of magnetic particles is imperfect, and some separation mechanisms are

difficult to apply in a manufacturing process. An improved magnetic grain isolation method is desired.

The current perpendicular recording media (so called granular media) is processed using O₂ reactive sputtering technique, and oxide dispersants to achieve smaller and physically isolated grains, and also uses a thick amorphous soft magnetic under layer (SUL) such as Fe, Ni, or Co-based alloy films as a mirror pole for recording performance. The Fe-based SUL forms a part of the media design. Since the SUL is based on iron, these alloy films are prone to severe corrosion. Because these Fe-based SUL films and other media layers are hard to cover at disk edges (chamfer area) as well as at mechanical defects (voids, pits etc) by the carbon overcoat material, harsh environmental conditions (HCl and water vapors at ambient and elevated temperatures) make the edges and other mechanical defects at the data zone area severely susceptible to corrosion. This produces edge corrosion at the edges and defect corrosion at voids and other mechanical defects. Hence, solution(s) that provide a corrosion-resistant SUL in the perpendicular media design and prevents the edge as well as the mechanical defect corrosion of the perpendicular media is desired.

SUMMARY OF THE INVENTION

The invention provides a perpendicular magnetic recording medium having high areal recording density exhibiting low noise and high corrosion resistance. One way of achieving this goal is to produce a soft magnetic film in the perpendicular magnetic recording medium having a Fe-based SUL, preferably an amorphous Fe-based SUL, having doped Cr to improve the corrosion performance of perpendicular media. The amorphous Fe-based SUL films more preferably are ternary Fe-alloys comprising Co and B doped with various levels of Cr.

One embodiment is a perpendicular magnetic recording medium comprising a substrate, a Cr-doped Fe-alloy-containing underlayer comprising about 8 to 18 at % Cr and a perpendicular recording magnetic layer. Preferably, the recording medium comprises a substantially radial or transverse anisotropy. Preferably, the underlayer provides a return path for a recording head. Preferably, the underlayer comprises a soft magnetic material. Preferably, the soft magnetic material is substantially amorphous. In one variation, the recording medium further comprises a seedlayer that changes a magnetostriction of the underlayer. Preferably, the Fe-alloy is selected from the group consisting of a FeCoB alloy, a CoFeZr alloy, a CoFeTa alloy, and a FeCoZrB alloy.

Another embodiment is a method of improving corrosion resistance of a magnetic recording medium comprising sputtering Cr-doped FeCoB directly from a candidate target material comprising Cr-doped FeCoB, forming a Cr-doped FeCoB containing underlayer on a substrate and depositing a magnetic perpendicular recording layer on the Cr-doped FeCoB containing underlayer, wherein the Cr-doped FeCoB containing underlayer has a polarization resistance of at least 1×10^5 ohm-cm². Preferably, the polarization resistance is at least 1×10^6 ohm-cm². Preferably, the material is a Fe-alloy. Preferably, the Fe-alloy is selected from the group consisting of a FeCoB alloy, a CoFeZr alloy, a CoFeTa alloy and a FeCoZrB alloy. Preferably, the underlayer comprises a soft magnetic material. Preferably, the soft magnetic material is substantially amorphous. Preferably, the Cr-doped underlayer comprises about 10-16 at % Cr.

Another embodiment is a method of manufacturing a magnetic recording medium, comprising co-depositing Cr with a Fe-containing material in a sputter chamber to form a Cr-

doped Fe-containing underlayer on a substrate and depositing a magnetic perpendicular recording layer. Preferably, the Fe-containing material is a Fe-alloy. Preferably, the Fe-alloy is selected from the group consisting of a FeCoB alloy, a CoFeZr(or Ta) alloy, and a FeCoZrB alloy. Preferably, the underlayer comprises an amorphous soft magnetic material. Preferably, the Cr-doped Fe-containing underlayer comprises about 10-16 at % Cr.

As will be realized, this invention is capable of other and different embodiments, and its details are capable of modifications in various obvious respects, all without departing from this invention. Accordingly, the drawings and description are to be regarded as illustrative in nature and not as restrictive.

BRIEF DESCRIPTION OF THE DRAWINGS

FIG. 1 is a schematic of an embodiment of a perpendicular recording medium of this invention.

FIG. 2 is a schematic of a perpendicular recording disk medium as incorporated in a disk drive.

FIG. 3 shows potentiodynamic scans of Cr-doped FeCoB alloy films.

FIG. 4 shows polarization resistance of various Cr-doped FeCoB alloy films.

FIG. 5 shows edge corrosion coverage and magnetic moment for various Cr-doped FeCoB alloy films.

FIG. 6 shows the corrosion performance of the undoped and Cr-doped soft underlayer perpendicular media after 80°/80% T/RH exposure. a) Undoped soft underlayer media edge corrosion (arrow), b) Clean Cr-doped soft underlayer media edges free of edge corrosion, c) Undoped media data zone area showing void corrosion, and d) Cr-doped soft underlayer media data zone area free of void corrosion.

DETAILED DESCRIPTION

A preferred embodiment of a perpendicular recording medium of this invention is shown in FIG. 1. The thickness of seedlayer **11** is about 1-10 nm, preferably, about 2-5 nm. The thickness of the amorphous soft magnetic underlayer **12** is preferably greater than 30 nm, more preferably, about 100-200 nm, and the thickness of magnetic recording layer **15** deposited on the underlayer is about 10-20 nm. In between the amorphous soft magnetic underlayer **12** and the magnetic recording layer **15** could be an intermediate layer **13** and **14** of thickness of about 5-30 nm. Protective layer **16** typically covers the magnetic recording layer **15**.

A perpendicular recording disk medium as incorporated in a disk drive is shown in FIG. 2. The perpendicular recording disk medium has soft magnetic underlayer **31**. The magnetic layer **32** of the perpendicular recording disk medium comprises domains oriented in a direction perpendicular to the plane of the substrate **30**. Also, FIG. 1 shows the following: (a) a read-write head **33** located on the recording medium, (b) traveling direction **34** of head **33** and (c) transverse direction **35** with respect to the traveling direction **34**.

This invention provides magnetic recording media suitable for high areal recording density exhibiting high SMNR. This invention achieves such technological advantages by forming a soft underlayer. A "soft magnetic material" is a material that is easily magnetized and demagnetized. As compared to a soft magnetic material, a "hard magnetic" material is one that neither magnetizes nor demagnetizes easily.

The underlayer is "soft" because it is made up of a soft magnetic material, which is defined above, and it is called an "underlayer" because it resides under a recording layer. In a

preferred embodiment, the soft layer is amorphous. The term "amorphous" means that the material of the underlayer exhibits no predominant sharp peak in an X-ray diffraction pattern as compared to background noise. The "amorphous soft underlayer" of this invention encompasses nanocrystallites in amorphous phase or any other form of a material so long the material exhibits no predominant sharp peak in an X-ray diffraction pattern as compared to background noise.

When soft underlayers are fabricated by magnetron sputtering on disk substrates, there are several components competing to determine the net anisotropy of the underlayers: effect of magnetron field, magnetostriction of film and stress originated from substrate shape, etc. Although the effect of magnetron field is not easy to be controlled without changing the design of equipment, the effect of magnetostriction and stress is very easy to be controlled by changing the sputtering conditions.

Also, the soft magnetic under layers can be fabricated as single layers or multilayers with Ru or suitable spacer materials in between the soft under layers to enhance the signal to noise ratio (SNR) by antiferromagnetic coupling.

The fabrication of the soft underlayer target could be important in getting the desired film structure and properties without any magnetic and structural defects. The soft magnetic layer targets are manufactured by procedures outlined below in order to facilitate sputtering of thin films with desired magnetic and structural properties. This process uses a mixture of elemental metals and boron powder as starting ingredients to make Cr-doped FeCoB targets instead of the expensive gas atomized alloyed powder(s) process (AP). The consolidated weight is melted in a vacuum induction melter (VIM), cast into a mold at a temperature between 1200 to 1550° C., and solidified into an ingot. The ingot is then pre-heated to a temperature between 850 and 1200° C. in an annealing furnace suitable for rolling to desired thickness for final machining to precise target size. The key difference between VIM process and AP route is that the atomized powders of the ingredients could contain high level of oxygen, and to go through oxygen reduction process could be expensive.

A seedlayer is a layer lying in between the substrate and the underlayer. Proper seedlayer can also control anisotropy of the soft underlayer by promoting microstructure that exhibit either short-range ordering under the influence of magnetron field or different magnetostriction. A seedlayer could also alter local stresses in the soft underlayer. Thus, one embodiment of this invention relates to a method of inducing radial anisotropy in soft underlayers by seedlayer.

In a preferred embodiment, a magnetron field produces the radial anisotropy in the soft underlayer. In a magnetron, electrons generated from a heated cathode move under the combined force of a radial electric field and an axial magnetic field. By its structure, a magnetron causes moving electrons to interact synchronously with traveling-wave components of a microwave standing-wave pattern in such a manner that electron potential energy is converted to microwave energy with high efficiency.

The magnetron is a device of essentially cylindrical symmetry. On the central axis is a hollow cylindrical cathode. The outer surface of the cathode carries electron-emitting materials, primarily barium and strontium oxides in a nickel matrix. Such a matrix is capable of emitting electrons when current flows through the heater inside the cathode cylinder.

At a radius somewhat larger than the outer radius of the cathode is a concentric cylindrical anode. The anode serves two functions: (1) to collect electrons emitted by the cathode and (2) to store and guide microwave energy. The anode

comprises a series of quarter-wavelength cavity resonators symmetrically arranged around the cathode.

A radial dc electric field (perpendicular to the cathode) is applied between cathode and anode. This electric field and the axial magnetic field (parallel and coaxial with the cathode) introduced by pole pieces at either end of the cathode, as described above, provide the required crossed-field configuration.

Preferably, in the underlayer of the perpendicular recording medium of this invention, an easy axis of magnetization is directed in a direction substantially transverse to a traveling direction of the magnetic head. This means that the easy axis of magnetization is directed more toward a direction transverse to the traveling direction of the read-write head than toward the traveling direction. Also, preferably, the underlayer of the perpendicular recording medium has a substantially radial or transverse anisotropy, which means that the domains of the soft magnetic material of the underlayer are directed more toward a direction transverse to the traveling direction of the read-write head than toward the traveling direction.

Typically, when a magnetic recording medium is a tape, the tape travels and the head is stationary. Therefore, a traveling direction of the magnetic head of a stationary head of a recording device in which the magnetic recording tape moves is the direction in which the head "travels" spatially with respect to the magnetic recording tape.

In accordance with embodiments of this invention, the substrates that may be used in the invention include glass, glass-ceramic, NiP/aluminum, metal alloys, plastic/polymer material, ceramic, glass-polymer, composite materials or other non-magnetic materials. Glass-ceramic materials do not normally exhibit a crystalline surface. Glasses and glass-ceramics generally exhibit high resistance to shocks.

A preferred embodiment of this invention is a perpendicular recording medium comprising an amorphous soft underlayer and a recording layer. The amorphous soft underlayer should preferably be made of soft magnetic materials and the recording layer should preferably be made of hard magnetic materials. The amorphous soft underlayer is relatively thick compared to other layers. Any layer between the amorphous soft underlayer and the recording layer is called an interlayer or an intermediate layer. An interlayer can be made of more than one layer of non-magnetic materials. The purpose of the interlayer is to prevent an interaction between the amorphous soft magnetic underlayer and recording layer. An interlayer could also promote the desired properties of the recording layer. Longitudinal recording media do not have an amorphous soft magnetic underlayer. Therefore, the layers named as "underlayer," "seed layer," "sub-seed layer," or "buffer layer" of longitudinal media are somewhat equivalent to the intermediate layer(s) of perpendicular media.

The underlayer and magnetic recording layer could be sequentially sputter deposited on the substrate, typically by magnetron sputtering, in an inert gas atmosphere. A carbon overcoat could be typically deposited in argon with nitrogen, hydrogen or ethylene. Conventional lubricant topcoats are typically less than about 20 Å thick.

When soft underlayers are fabricated by magnetron sputtering on disk substrates, there are several components competing to determine the net anisotropy of the underlayers: effect of magnetron field, magnetostriction of film and stress originated from substrate shape, etc. A seedlayer, which could be optionally added as a layer lying in between the substrate and the soft underlayer, can often control anisotropy of the soft underlayer by promoting microstructure that exhibit either short-range ordering under the influence of

magnetron field or different magnetostriction. A seedlayer could also alter local stresses in the soft underlayer.

Amorphous soft underlayers produced smoother surfaces as compared to polycrystalline underlayers. Therefore, it was recognized by this invention that the use of amorphous soft underlayer is one way of reducing the roughness of the magnetic recording media for high-density perpendicular magnetic recording. The amorphous soft underlayers materials include a Cr-doped Fe-alloy-containing underlayer, wherein the Fe-alloy could be CoFeZr, CoFeTa, FeCoZrB and FeCoB.

Another advantage of amorphous materials as soft underlayer materials is the lack of long-range order in the amorphous material. Without a long-range order, amorphous alloys have substantially no magnetocrystalline anisotropy. According to this invention, the use of amorphous soft underlayer is one way of reducing noise caused by ripple domains and surface roughness. The surface roughness of the amorphous soft underlayer is preferably below 0.4 nm, more preferably below 0.3 nm, and most preferably below 0.2 or 0.1 nm.

In accordance with this invention, the average surface roughness (R_a) refers to the arithmetic average of the absolute values of the surface height deviations measured from a mean plane. The value of the mean plane is measured as the average of all the Z values within an enclosed area. The mean can have a negative value because the Z values are measured relative to the Z value when the microscope is engaged. This value is not corrected for tilt in the plane of the data; therefore, plane fitting or flattening the data will change this value.

$$R_a = (|Z_1| + |Z_2| + \dots + |Z_n|) / N$$

The surface parameters of a layer such as that of the soft underlayer could be measured by atomic force microscope (AFM). The AFM used to characterize this invention has the trade name NanoScope.® The statistics used by the AFM are mostly derived from ASME B46.1 ("Surface Texture: Surface Roughness, Waviness and Law") available from the American Society of Mechanical Engineers, which is incorporated herein by reference.

Applicants recognized that the soft-underlayers manufactured according to the current methods have radial magnetic anisotropy induced by a field and altered magnetostriction by seedlayer by considering all possible origins of magnetic anisotropy:

(1) Magnetocrystalline anisotropy: Sputtered thin films listed as examples in this application form poly-crystalline microstructure. Crystallographic orientation of micro-crystals in the films is random in the plane of disk. There is no reason why they form differently in radial and circumferential direction. Therefore, the disks of this invention do not have magnetocrystalline anisotropy.

(2) Shape anisotropy: This also does not explain the anisotropy between radial and circumferential direction of the disks of this invention.

(3) Stress anisotropy: Magnetostriction can cause stress-induced anisotropy.

(4) External field induced anisotropy: When an external magnetic field is applied during film deposition, it can create short-range ordering that produces magnetic anisotropy in the direction of applied field. This method is used in manufacturing a read-write head of a recording medium. Similarly, this invention utilizes a magnetron field to apply a field in the radial direction of disks to produce radial anisotropy.

A perpendicular recording medium of this invention comprises a soft underlayer and a recording layer. A soft underlayer should preferably be made of soft magnetic materials and the recording layer should preferably be made of hard

magnetic materials. A soft underlayer is relatively thick compared to other layers. Any layers between the soft underlayer and the recording layer is called interlayer or intermediate layer. An interlayer can be made of more than one layer of non-magnetic materials. The purpose of the interlayer is to prevent an interaction between the soft magnetic underlayer and recording layer. An interlayer could also promote the desired properties of the recording layer. Conventional (longitudinal) media do not have a soft magnetic underlayer. Therefore, the layers named as "underlayer," "seed layer," "sub-seed layer," or "buffer layer" of longitudinal media are somewhat equivalent to the intermediate layer(s) of perpendicular media.

In the preferred embodiment of the perpendicular media, it was easier to saturate the sample in radial direction than in circumferential direction. Thus, radial and circumferential directions are called the easy and hard axis, respectively. The underlayers of the disks could also have radial anisotropy. "Anisotropy" could be determined as described in U.S. Pat. No. 6,703,773, which is incorporated herein in entirety by reference.

The advantageous characteristics attainable by the present invention, particularly, as related to reduction or elimination of DC noise and improved corrosion resistance, are illustrated in the following examples.

EXAMPLES

All samples described in this disclosure were fabricated with DC magnetron sputtering except carbon films were made with AC magnetron sputtering.

Cr enhances the passive state of iron even with low coverage possibly due to the formation of a Cr-enriched passive film. The Cr-doping was done by co-depositing Cr with a FeCoB alloy in a sputter chamber on to clean NiP/Al substrates. Alternatively, the Cr-doped FeCoB films could be directly sputtered onto the disk substrates that will eventually be built into disk media from the Cr-doped FeCoB targets. A manufacturing process of such targets was briefly discussed above. The films were made to a thickness of 500-600 Å with and without a ~40 Å carbon overcoat. These films were tested for electrochemical corrosion performance (at ambient in 0.1N NaCl) and compositional analysis by X-ray electron spectroscopy. The carbon-coated films were used for magnetic measurements as well as HCl vapor exposure experiment. FIG. 3 shows the potentiodynamic scans of Cr-doped FeCoB alloy films with varying Cr-content. The Cr at % was varied from 0 to 40% in the FeCoB alloy. As can be seen from the chart, as the Cr % increases, the passivity (decreasing corrosion current) as well as the nobility of the film increases (increasing open circuit potential). The chart is an example of how Cr addition helps improve the corrosion performance of FeCoB alloy films. As can be seen from the graph, the "increasing passivity" arrow points towards increasing Cr content in the alloy, which clearly shows increasing Cr in the alloy decreases the corrosion (current). Also, increasing "nobility" as shown by an arrow indicates that by adding Cr in the FeCoB alloy, the corrosion potential increases. The corrosion potential is a potential above which the anodic corrosion starts to occur. The higher the corrosion potential, the lower is the inertia for corrosion to initiate.

To further verify the observation of improved corrosion resistance with Cr at % increase in the underlayer shown in FIG. 3, electrochemical impedance spectroscopy (EIS) measurements were done for these samples in aerated 0.1N NaCl electrolyte, and the polarization resistance was calculated from the spectra. As shown in FIG. 4, as the Cr-content

increases, the polarization resistance increases and reaches a maximum at a Cr concentration of 11-15 at % (ESCA composition). From this data, it is clear that a preferred minimum amount of Cr in a Fe-alloy-containing underlayer would be about 8 at % Cr, preferably, about 9 or 10 at % Cr, and most preferably about 11 to 18 at % Cr to protect the FeCoB films from edge as well as general corrosion.

In order to see how these films perform in HCl vapor exposure, a 24-hr vapor exposure test above 0.5N HCl solution in an enclosed container was made, and the results are plotted in FIG. 5 along with the magnetic properties.

As shown in FIG. 5, as the Cr at % increases, the % of edge corrosion decreases from 100% coverage for the 0 at % Cr to almost 0% corrosion for 11 at % Cr doped FeCoB films. On the other hand, the magnetic moment (Bs) decreased by only about ~30% for 11 at % Cr-containing films from a 0% Cr doped FeCoB alloy films.

Also, additional experiments were carried out at different environmental conditions other than HCl exposure to see the corrosion performance of the new media having Cr-doped soft underlayer. Both the Cr-doped soft underlayer perpendicular media and the undoped soft underlayer perpendicular media were subjected to environmental exposure at 80° C. with a relative humidity of 80% for 4 days. After the exposure, the disks were examined using an optical microscope (for edge corrosion defects) as well as a surface reflectance analyzer tester (for void corrosion defects in the data zone area) to see whether there are any corrosion growths. As shown in FIG. 6a, the undoped soft underlayer perpendicular media shows a typical edge corrosion defects (arrow) whereas the Cr-doped FeCoB soft underlayer shows a clean edge without any corrosion (FIG. 6b). On the other hand, the surface reflectance analyzer shows there are numerous void type corrosion in the data zone area (FIG. 6c), whereas the Cr-doped soft underlayer media shows almost a clean surface with few defects probably related to mechanical damage (FIG. 6d).

Based on the above unexpected experimental results, applicants recognized that preferably one should dope a minimum of about 8 at % Cr, preferably a minimum of about 10 at % Cr, more preferably of about 11 at % Cr, in a Fe-alloy-containing SUL such as FeCoB or other Fe and FeCo based SUL alloys to prevent the edge and general corrosion defects in perpendicular media. Also, keeping in mind the drop in the magnetic moment with increasing at % Cr in the underlayer film, the preferred range of doped Cr in a Fe-alloy-containing SUL should be 8-18 at % Cr, the more preferred range should be 10-16 at % Cr, and the most preferred range should be 11-15 at % Cr.

The above description is presented to enable a person skilled in the art to make and use the invention, and is provided in the context of a particular application and its requirements. Various modifications to the preferred embodiments will be readily apparent to those skilled in the art, and the generic principles defined herein may be applied to other embodiments and applications without departing from the spirit and scope of the invention. Thus, this invention is not intended to be limited to the embodiments shown, but is to be accorded the widest scope consistent with the principles and features disclosed herein.

This application discloses several numerical range limitations that support any range within the disclosed numerical ranges even though a precise range limitation is not stated verbatim in the specification because this invention can be practiced throughout the disclosed numerical ranges. Finally, the entire disclosure of the patents and publications referred in this application are hereby incorporated herein in entirety by reference.

The invention claimed is:

1. A perpendicular magnetic recording medium comprising:

a substrate;
 a perpendicular recording magnetic layer; and
 an underlayer between the substrate and the perpendicular recording magnetic layer, the underlayer comprising an Fe-alloy and about 8 to about 18 at percent Cr, wherein the Fe-alloy is selected from the group consisting of a FeCoB alloy, a CoFeZr alloy, a CoFeTa alloy, and a FeCoZrB alloy.

2. The recording medium of claim 1, wherein the recording medium comprises a substantially radial or transverse anisotropy.

3. The recording medium of claim 1, wherein the underlayer provides a return path for a recording head.

4. The recording medium of claim 1, wherein the underlayer comprises a soft magnetic material.

5. The recording medium of claim 1, further comprising a seedlayer that changes a magnetostriction of the underlayer.

6. The recording medium of claim 1, wherein the underlayer material is substantially amorphous.

5 7. The recording medium of claim 6 wherein the underlayer has a surface roughness below 0.4 nm.

8. The recording medium of claim 1, wherein the underlayer comprises about 11 to about 15 at. percent Cr.

9. The recording medium of claim 1, wherein the underlayer has a thickness greater than 30 nanometers.

10 10. The recording medium of claim 1, wherein the underlayer has a thickness between about 100 nm and about 200 nm.

11. The recording medium of claim 1, wherein the perpendicular recording magnetic layer has a thickness between about 5 nm and about 30 nm.

* * * * *