



718 Juniper Place • Tsawwassen, BC • V4L 2J2  
ensc440-thermacool@sfu.ca

---

April 24, 2005

Lakshman One  
School of Engineering Science  
Simon Fraser University  
Burnaby, British Columbia  
V5A 1S6

Re: ENSC 440 Post Mortem for a Temperature Controlled Mattress Pad

Dear Mr. One,

Please find attached our ENSC 440 course project post mortem entitled "*Post Mortem for a Temperature Controlled Mattress Pad*". The report outlines the process we undertook to design and implement our final product, and emphasizes the deviations between the original and the final design of our temperature controlled mattress pad.

The post mortem discusses specific details about the project - its current state, how it is different from the original concept, and future considerations for further development of the product. The post mortem also reviews how closely we followed our budget and time line, and how well we worked together as a team. In addition, it outlines the knowledge and experience we've gained from working on the project.

ThermaCool is a new and exciting organization consisting of four enthusiastic and eager fourth year Systems Engineering students. The team members include Slav Bienko, David Black, Sal Daswani, and Sean Pallister. Please feel free to contact us with any comments or questions regarding our proposal or product. We can be reached by telephone at 604-943-1418, or by email at [ensc440-thermacool@sfu.ca](mailto:ensc440-thermacool@sfu.ca).

Sincerely,

A handwritten signature in blue ink, appearing to read "D. Black".

David Black  
Organization Department Head  
ThermaCool Inc.

Enclosed: *Post Mortem for a Temperature Controlled Mattress Pad*



---

ThermaCool Inc.

Post Mortem for a  
**Temperature Controlled Mattress Pad**

---

---

*Project Team:* Slav Bienko  
David Black  
Sal Daswani  
Sean Pallister

*Contact Person:* David Black  
ensc440-thermacool@sfu.ca

*Submitted to:* Lakshman One – ENSC 440  
Michael Sjoerdsma – ENSC 305  
School of Engineering Science  
Simon Fraser University

*Issued date:* April 24, 2005

*Revision:* 4.0



## TABLE OF CONTENTS

1	Introduction.....	1
2	The Prototype Perfect Balance Mattress Pad .....	1
2.1	The Processing Unit .....	1
2.2	The Heat Exchanger.....	2
2.3	The Reservoir Unit .....	3
2.4	The Mattress Pad and Temperature Sensors .....	3
2.5	The Control Unit .....	3
3	Deviation from desired operation .....	4
3.1	Functionality Deviations.....	4
3.2	Design Deviations.....	4
3.2.1	Powering the system .....	4
3.2.2	The Mattress Pad.....	6
3.2.3	The TEC Drivers.....	6
3.2.4	The Reservoir Unit.....	6
3.2.5	Programming Changes .....	6
4	Future plans: the marketable perfect balance mattress pad.....	8
4.1	The Processing Unit.....	8
4.2	The Heat Exchanger.....	8
4.3	The Reservoir Unit .....	8
4.4	The Mattress Pad and Temperature Sensors .....	9
4.5	The Control Unit .....	9
5	Budgetary and Time Constraints .....	10
5.1	Budgetary Constraints .....	10
5.2	Time Constraints.....	10
6	Personal Experiences.....	12
6.1	Slav Bienko .....	12
6.2	David Black.....	13
6.3	Sal Daswani.....	13
6.4	Sean Pallister .....	14
7	Acknowledgments.....	15



8 Conclusion ..... 16  
9 Sources and References..... 17

**TABLE OF FIGURES**

Figure 2-1: The Perfect Balance Mattress Pad System Overview ..... 1  
Figure 2-2: A TEC driver..... 2  
Figure 2-3: Power supply and various hardware items ..... 2  
Figure 2-4: Heat exchanger components, the heat sink and milled aluminum block ..... 2  
Figure 2-5: The reservoir unit..... 3  
Figure 2-6: Mattress pad corner section ..... 3  
Figure 2-7: The control unit ..... 3  
Figure 3-1: The Diagrams for the previous 350W and 5V Power Supplies ..... 4  
Figure 3-2: The block diagrams for the current 800W and 5V Power Supplies..... 5  
Figure 5-1: Gantt Chart of Scheduled Completion Dates for Various Parts of the Project... 11  
Figure 5-2: Gantt Chart of Completion Dates for Various Parts of the Project..... 11

## 1 INTRODUCTION

Over the past four months the ThermaCool team has created a prototype for the first mattress pad capable of heating and cooling users. Coined the Perfect Balance Mattress Pad, ThermaCool's creation has astounded those who have used it to date. In this document the process used to take the Perfect Balance Mattress Pad from an idea to reality is examined. In addition, the actual features of the Perfect balance Mattress Pad will be compared to those outlined in the Functional Specification.

## 2 THE PROTOTYPE PERFECT BALANCE MATTRESS PAD

In its current state, the Perfect balance Mattress Pad operates as is shown below in Figure 2-1.

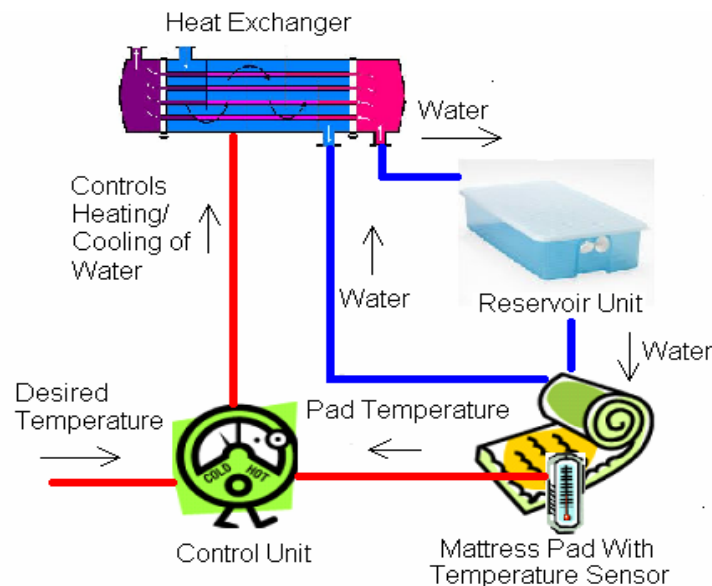

**Figure 2-1:** The Perfect Balance Mattress Pad System Overview

Referring to Figure 2-1, the user sets a desired temperature using the control unit. The desired temperature set by the user will be compared to the actual temperature of the mattress pad using the control unit. Subsequently, the control unit will control the amount of current to the heat exchanger, which in turn controls the heating or cooling of the water via Thermoelectric Cooling Modules (TECs). Water flows through the system from the reservoir unit, to the mattress pad, to the heat exchanger and back to the reservoir unit in a closed loop.

### 2.1 The Processing Unit

Not shown in the above Figure is the heart of ThermaCool's system: the processing unit. The processing unit consists of hardware which enables the entire system to function. The main components of this hardware are the TEC drivers, the PIC microcontroller and the

power supply. Figures 2-2 and 2-3 show a TEC driver and the power supply and main hardware components respectively.

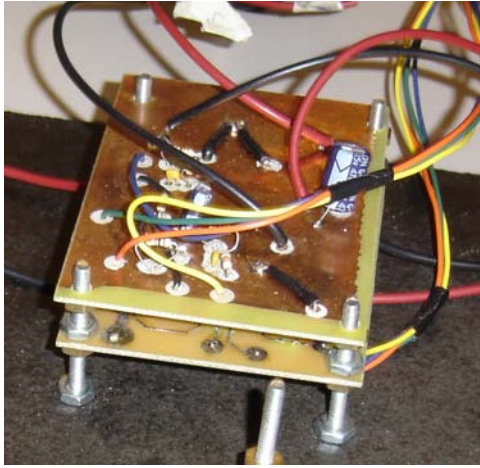

**Figure 2-2:** A TEC driver

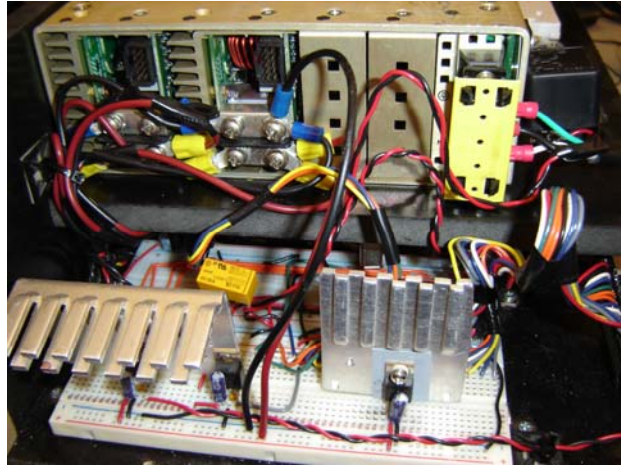

**Figure 2-3:** Power supply and various hardware items

## 2.2 The Heat Exchanger

The heat exchanger is responsible for thermally treating the water used to heat and cool the mattress pad. It consists of four TECs, a large heat sink, a milled piece of aluminum through which water flows, and five fans. The heat sinks and fans are used to dissipate heat generated from the TECs during cooling. The TECs are powered by the TEC drivers located in the processing unit. Shown below in Figure 2-4 is the heat sink and milled piece of aluminum.

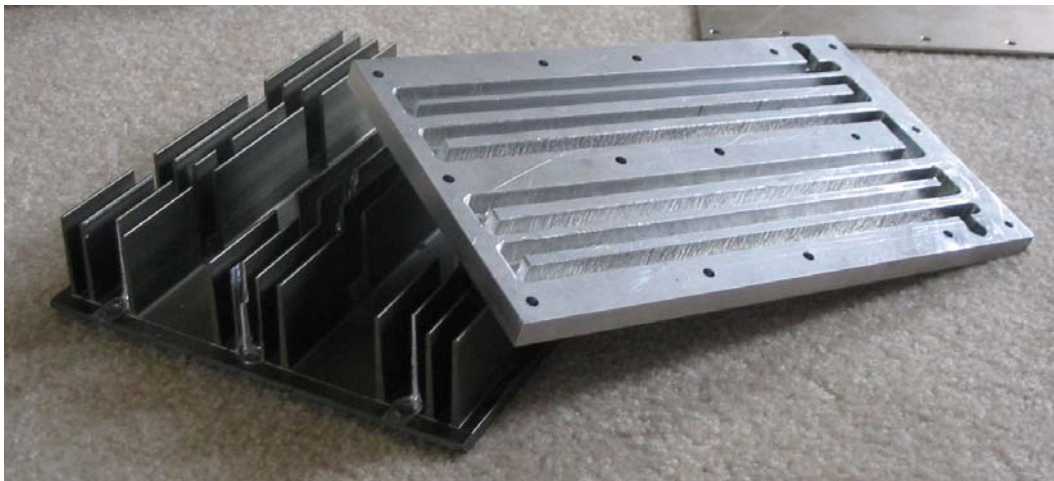

**Figure 2-4:** Heat exchanger components, the heat sink and milled aluminum block

## 2.3 The Reservoir Unit

The reservoir unit, shown in Figure 2-5, consists of a plastic container wrapped in insulation, and a pump. This unit is used to keep the thermally treated water from the reservoir unit at a constant temperature, as well as circulate water throughout the entire system. Also inside this unit is a thermistor, which is used as a safety feature to ensure that the temperature of the water does not exceed the limits of 15°C and 35°C.

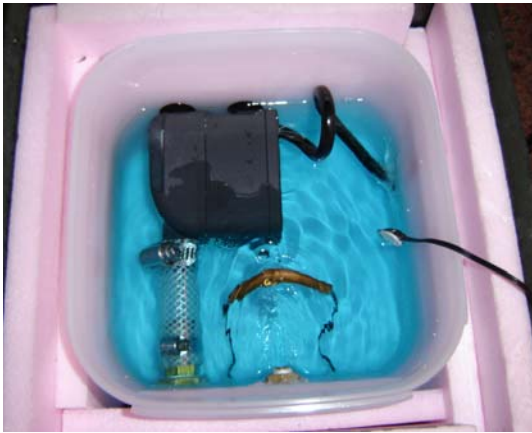

Figure 2-5: The reservoir unit



Figure 2-6: Mattress pad corner section

## 2.4 The Mattress Pad and Temperature Sensors

Three temperature sensors are located on one side of the mattress pad, on the bottom, middle and top sections. These sensors are responsible for measuring the actual pad temperature, which is fed back to the control unit. The mattress pad is designed in such a way that pinching of the water flow through the pad will not occur when pressure is applied (a person is lying on the pad). This design is apparent in Figure 2-6 above, which shows a portion of the mattress pad.

## 2.5 The Control Unit

The user communicates with the system via the control unit, which is pictured in Figure 2-7. Buttons on the control unit allow the user to control the desired temperature, and view the actual or desired temperature in both Celsius and Fahrenheit. Furthermore, the control unit contains a button that allows the user to turn on or off the entire system.



Figure 2-7: The control unit

### 3 DEVIATION FROM DESIRED OPERATION

#### 3.1 Functionality Deviations

ThermaCool was almost completely successful in achieving all of the functional aspects of the system as originally planned. We were unable to keep the processing unit or the reservoir unit below 6 inches in height; they were 6.25 inches in height. Another functionality aspect that we were unable to accomplish was cooling the mattress pad to 15°C. We were able to achieve a cooling temperature of 22.6°C, which felt quite cold since it was liquid temperature rather than air temperature. The rest of the deviations are design deviations, and will be discussed below.

#### 3.2 Design Deviations

##### 3.2.1 Powering the system

The components used for powering the entire system have changed significantly. Figure 3-1 shows the old design, while Figure 3-2 shows the current design.

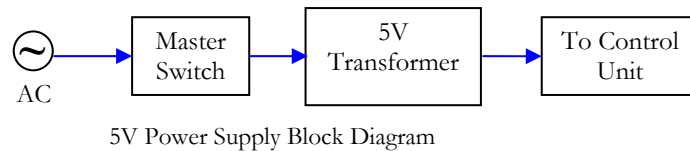
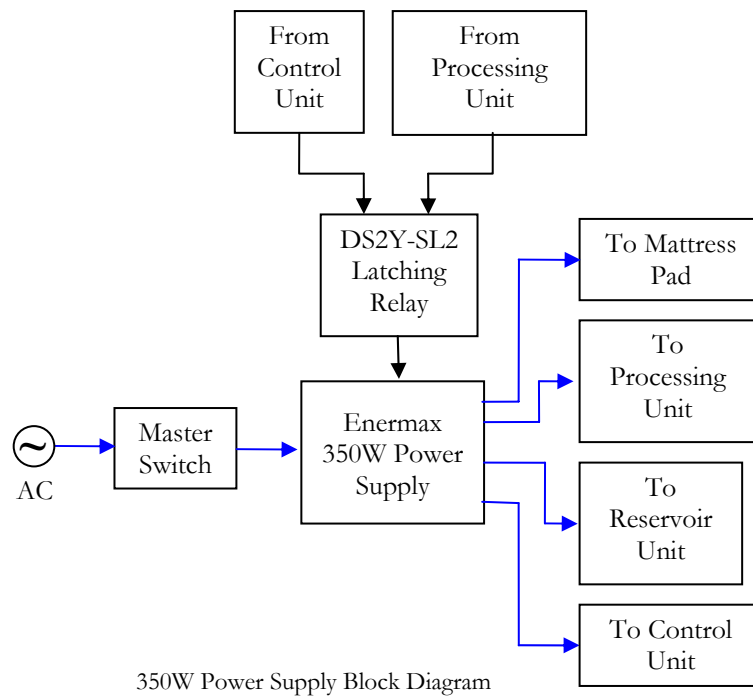

**Figure 3-1:** The Diagrams for the previous 350W and 5V Power Supplies



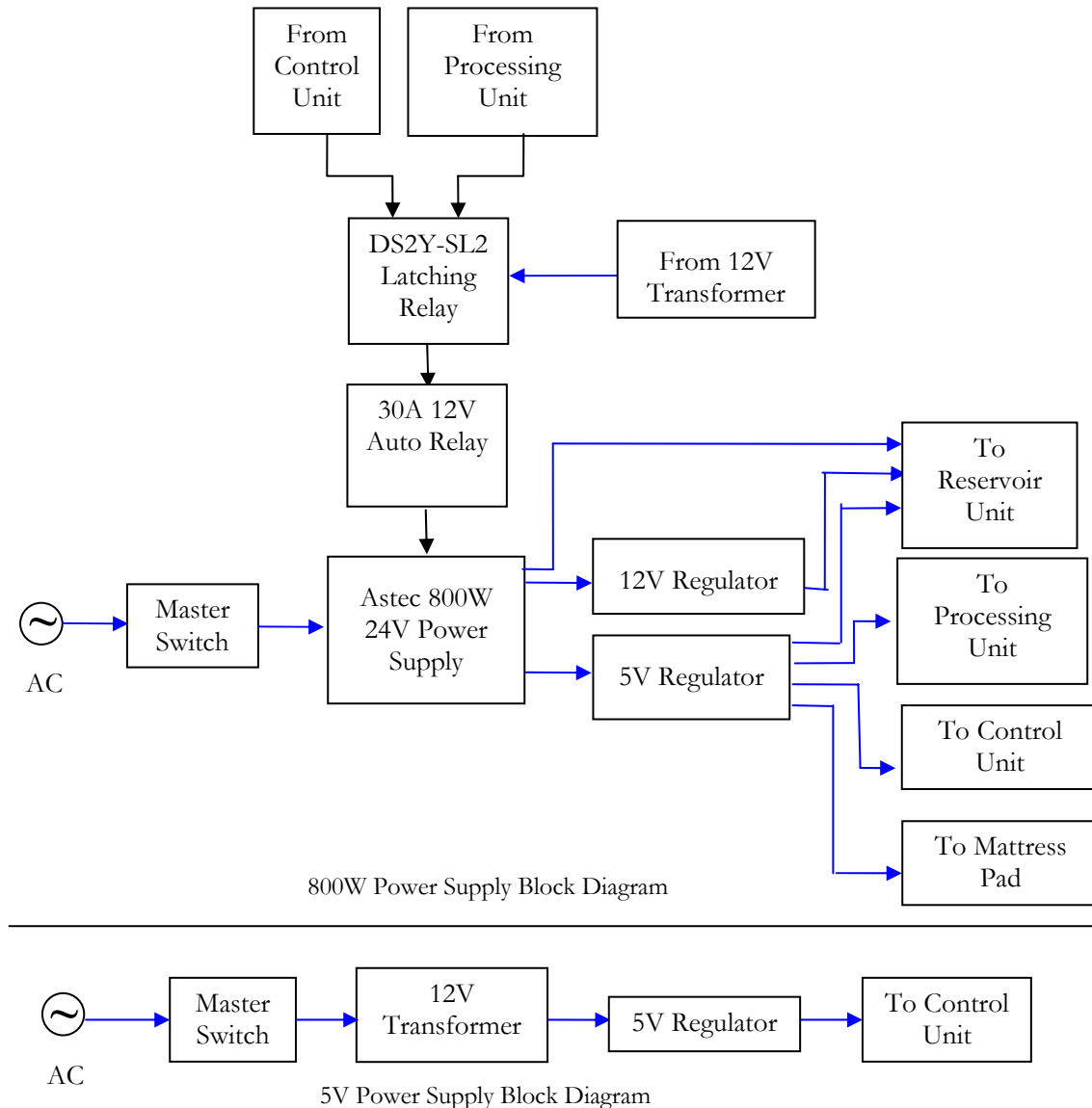

**Figure 3-2:** The block diagrams for the current 800W and 5V Power Supplies

The main reason for the change in components was that the manufacturer of the TECs informed us that the TECs run more efficiently at 24V. Also, at 24V, we would be able to reach higher amperages, meaning our cooling and heating power would improve. With the 350W power supply, we were only able to reach an amperage of 2.75A flowing through the TECs, whereas with the 800W power supply, we were able to reach amperages of up to 4.75A (since the power supply is 24V dual channel supply rated at 15A per channel).

Another change in the powering of the system was the introduction of another relay. Since the 800W power supply can draw much more current than the 350W power supply, we needed to obtain a much more powerful relay. Unfortunately, we could not find any

latching relays which were rated for over 15A. So, we attached our 5V, 2A latching relay to a 12V, 30A automotive relay. So, when the latching relay is activated by a 5V signal, it latches on and allows 12V from the 12V transformer to pass through it and activate the 12V, 30A automotive relay, which in turn activates the 800W power supply.

Since all the logic components in the system needed 5V to operate and all the fans needed 12V to operate, we introduced 5V and 12V regulators into our the system. So currently in our system, our logic circuits and fans are connected through voltage regulators that are interfaced with the 24V power supply. There is also a 12V transformer, which is then connected to a 5V regulator, which then supplies the power signal to the control unit.

We also had to buy a new master switch, one with a higher amperage rating, but that is a rather minor and insignificant change.

### **3.2.2 The Mattress Pad**

There was only one small change on the mattress pad, and that was the positioning of the temperature sensors. Instead of having three sensors spaced apart down the center line of the mattress pad (length wise), we decided to have the sensors spaced out (length wise) on the far side (opposite side of the intake and outtake valves) of the mattress pad. Also, the temperature sensors were mounted underneath the mattress pad instead of on top.

We placed the thermistors on the side of the mattress pad to reduce the effect of the user's body heat on the temperature readings. The thermistors were placed on the bottom, middle and top of the mattress pad in order to get an average reading of the temperature of the pad.

### **3.2.3 The TEC Drivers**

The only difference with the TEC drivers now is that they are being powered by 24V instead of 12V. The reasoning behind this was to increase the maximum possible current flow through the TECs. More importantly, the TECs are more efficient with respect to operation at 24V than at 12V.

### **3.2.4 The Reservoir Unit**

Upon running the system, we noticed that we were losing a lot of thermal energy in the reservoir unit, more specifically, around the heat exchanger. When we cooled, there was too much warm air around the heat exchanger, and thus we could not cool as much as we liked to. When we heated, we had no problem what so ever. So, in order to combat the issue of warm air warming the heat exchanger as we tried to cool, we simply insulated that section of the reservoir unit. We did so by filling all the open spaces around the outside of the heat exchanger with insulation, made the heat exchanger sit on insulation instead of leaving it floating in the air, and left all the direct paths of airflow insulation free. This insulation helped the heat exchanger retain the low temperature it was achieving when we tried to cool the system.

### **3.2.5 Programming Changes**

Almost all performance requirements associated with the Perfect Balance mattress pad were met. This includes such parameters as response time and accuracy. In the Functional

Specifications document for the Perfect Balance mattress pad [1], it was stated that the it should not take longer than 2 minutes to heat the surface of the mattress pad by 1°C. This requirement was met, and we observed heating of the mattress pad by nearly 2°C every two minutes in certain cases. However, the requirement of not taking longer than 5 minutes to cool the surface of the mattress pad by 1°C was not exactly met in full. This is to say that after cooling the surface of the mattress pad by a few degrees, the time required to cool the mattress pad by one more °C began to exceed the 5 minute specification. For this reason, we tried to investigate how we could optimize the cooling ability of our system. This was done by investigating what current flow through the TECs made for the best cooling situation. Of course one may think that full power to the TECs would maximize our cooling ability, however, due to our heatsink limitation, it was necessary to flow a current through the TECs that would not overheat the heatsink and result in an uncontrollable control loop that would eventually heat the water, rather than cool it. This investigation led to adjustments in the output Pulse-Width-Modulated signal that was instructing the H-Bridges how much current to flow through the TECs. Therefore, we lessened the maximum PWM duty cycle value (i.e. maximum current flow through the TECs) that was being sent to the H-Bridges when the mattress pad was in cooling mode.

Furthermore, to prevent thermal cycling, we implemented a 1°C deadband about the desired temperature. This deadband begins at 0.5°C below the desired temperature and extends to 0.5°C above the desired temperature.

## **4 FUTURE PLANS: THE MARKETABLE PERFECT BALANCE MATTRESS PAD**

While a prototype Perfect Balance Mattress Pad has been developed, a marketable version would require some additional work. Extra work needed for each major component of the Perfect Balance Mattress Pad is outlined below.

### **4.1 The Processing Unit**

As described in Section 2.1, the processing unit contains three main pieces of hardware that serve as the backbone for the Perfect Balance Mattress Pad. Members of ThermaCool created the TEC drivers by making PCB boards and soldering on components. In the marketable version of the Perfect balance Mattress Pad, the PCB boards would be outsourced. This outsourcing would allow the boards to be much smaller, and more *professional looking*. In addition, the power supply used to power the entire system would be specially designed for our unique purpose. Therefore, it would likely be smaller, and shaped to fit in a box of specific dimensions. Therefore, the box housing the processing unit, which was also made by the members of ThermaCool, would be smaller than it was in the prototype version.

### **4.2 The Heat Exchanger**

In the marketable version of the Prefect Balance Mattress Pad, the heat sink used to dissipate the heat from the TECs while cooling would be much more powerful than the heat sink used in the prototype. ThermaCool found that the bottleneck during cooling was the speed at which heat could be dissipated from the TECs. Therefore, a heat sink with much more surface area, specifically designed to suit our application would be used. Tests would be done to ensure that the heat sink would be able to efficiently dissipate heat even when the system was cooling to its maximum. In addition, fans used to dissipate the heat from the heat sinks would be quieter and stronger than the one used in the prototype. The fans used in the prototype were obtained from old PCs. However, the fans used in the marketable version of the Perfect balance Mattress Pad would be specifically designed for our purpose. In addition, the box housing the heat exchanger would be built in such a way that heat would be directed away from the unit itself.

### **4.3 The Reservoir Unit**

The reservoir unit would not need to be changed much to take the Perfect Balance Mattress pad to its marketable version. The insulation surrounding the plastic container holding the thermally treated water would be thicker, and made of a material more isolative than insulation. In addition, this insulation would also cover the lid of the plastic container rather than just the sides. The lid of the plastic container would also be permanently fastened to the container itself. The above changes would allow for better insulation of the thermally treated water.

## 4.4 The Mattress Pad and Temperature Sensors

The mattress pad itself would not be changed for the marketable version. However, the method by which the thermistors are mounted to the mattress pad would be changed. In the prototype version of the Perfect Balance Mattress Pad, the thermistors are fastened to the mattress pad using Scotch tape, and a small circular piece of tin foil is put between the tape and the thermistor in order to allow the thermistor to gather temperature data from a small area around its location. In the marketable version of the Perfect Balance Mattress Pad, the thermistors would be embedded into the mattress pad itself. The wires connecting the thermistors to the control unit would also be embedded in the pad itself. This way, there is little chance that either the wires or thermistors would become removed from the pad or damaged in some way by the user.

## 4.5 The Control Unit

The control unit is essentially marketable as it is. However, in the marketable version of the Perfect Balance Mattress Pad, the control unit would be made more ergonomically friendly. That is, it would be made such a shape that it could be easily held by the average sized hand.

Furthermore, the control unit may see the addition of one or two buttons to allow for a preheat/precool function. This function would allow the user to specify his/her typical bedtime through the current 4-digit LED display. After entering bedtime information, the Perfect Balance mattress pad system would then be able to automatically turn itself on before the user's bedtime (roughly half an hour or so, dependent upon the actual temperature) and either heat up or cool down the mattress pad such that the user's desired temperature would be met just in time for when he/she climbs into bed.

## 5 BUDGETARY AND TIME CONSTRAINTS

### 5.1 Budgetary Constraints

Table 5-1 shows the actual and estimated costs for the Perfect Balance Mattress Pad.

**Table 5-1:** Estimated and Actual Costs for the Perfect Balance Mattress Pad

Equipment		Estimated Cost	Actual Cost
Construction Materials	Water Pumps	\$120.00	\$30.00
	Tubing	70.00	0.00
	Mattress Pad	30.00	0.00
	Water Housing Case	45.00	10.00
	Misc. Construction Materials	20.00	55.00
Electronic Components	Thermoelectric Heaters and Coolers	110.00	65.00
	LED Screen	30.00	15.00
	Microcontroller	20.00	15.00
	Misc. IC's (DAC, Amps, Buffers)	40.00	85.00
	Power Supply and Regulation	40.00	140.00
	Connectors, Cables, Buttons	45.00	40.00
	Circuit Board	15.00	40.00
	Electronics Case	15.00	10.00
Misc. Costs	Shipping and Taxes	100.00	Included
	Cost Overrun Contingency	100.00	Included
<b>Total Cost</b>		<b>\$800.00</b>	<b>\$505.00</b>

As can be seen, ThermaCool managed to produce a prototype of the Perfect balance Mattress Pad for almost \$300 below what we originally anticipated. This positive discrepancy was due to the fact that ThermaCool obtained the mattress pad, tubing, fans, heatsink, connectors and other minor electronic components free of charge. However, ThermaCool is not aware of the actual costs of many of these components. If it were not for the generosity of certain individuals, ThermaCool may have been closer to their proposed budget or possibly even over budget.

### 5.2 Time Constraints

Figure 5-1 shows a Gantt chart of the time ThermaCool thought each stage of the prototype design and implementation would take us at the beginning of the semester.

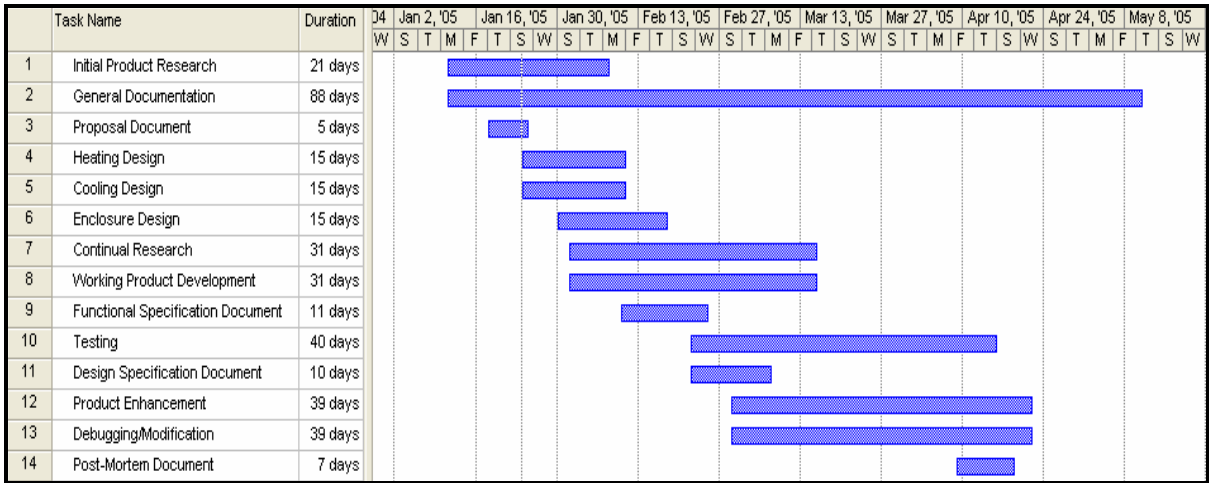

Figure 5-1: Gantt Chart of Scheduled Completion Dates for Various Parts of the Project

ThermaCool found that every stage took longer than initially projected. However, because we have four members in our team, we were able to have some members working in some areas, while some working in others. Thus, we were still able to finish the Perfect Balance Mattress pad by our demo time. If we had not split up, we feel that we would not have been able to complete the project. Shown in Figure 5-2 is an updated Gantt chart, showing the time overruns in red.

ThermaCool first got the Perfect balance Mattress pad to work on April 8, 2005. However, the internal system components were not assembled as we desired at this time. On the morning of April 21 at approximately 2:00am, the Perfect Balance Mattress Pad was tested, and worked in its prototype form. ThermaCool demonstrated that the Perfect Balance Mattress Pad to a group of approximately ten people on April 21 at 11:00am.

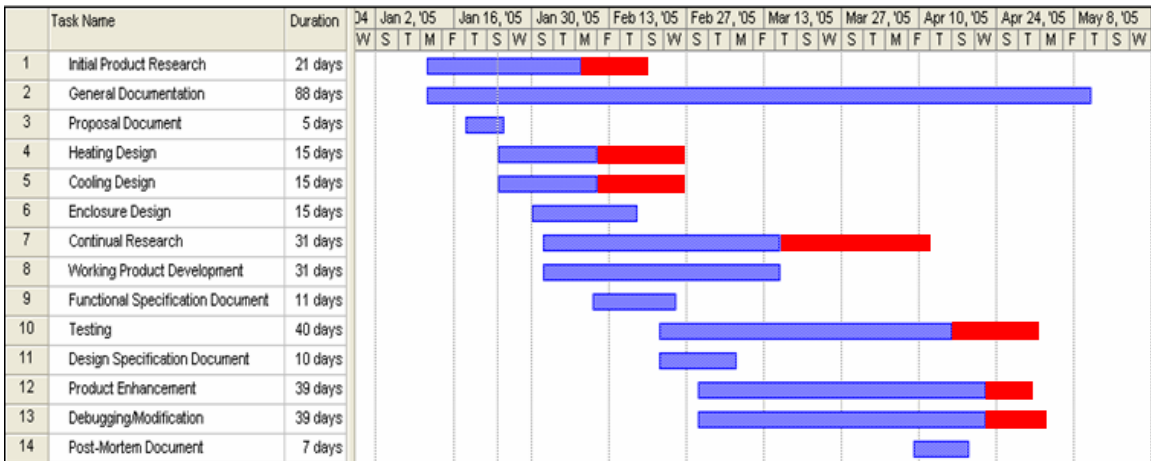

Figure 5-2: Gantt Chart of Completion Dates for Various Parts of the Project

## 6 PERSONAL EXPERIENCES

### 6.1 Slav Bienko

One of the most obvious topics that come to mind when I think back about what I learned over the past 13 weeks is the PIC microcontroller. I had no idea it would be so difficult to choose a microcontroller with all the right features and performance statistics that we needed. There were thousands of microcontrollers on digikey, all with varying properties. We had to look at price, response times, ADCs, memory size, I/O pins, and other important characteristics.

One of the most important programs and procedures I learned doing this program was Eagle and etching. Seeing as our H-bridges and low-side MOSFETs were all surface mount, I had to design a PCB for the TEC drivers. Of course Eagle did not have the parts I needed in their library, so I also learned how to create a package and footprint in Eagle. As I designed the PCB, I learned all about the dos and don'ts of routing. And after a first failed attempt at a budget etching job (the iron-on traces then etch using ferric chloride acid), we succeeded with the second budget etching job (printing our design on a transparency, then exposing the photo-sensitive copper to light, then developing the copper). In the end, the PCB's worked superbly.

I was mainly in charge of the physical construction of the entire system as well, so I learned about designing for comfort. I tried to construct the encasements so that the parts of the project that needed to be serviced by the user (such as the water reservoir) were easy enough for them to access. I also added to my previous milling experience, because I milled the entire heat exchanger from a solid piece of aluminum. I think I also became a bit more creative. I say this because you have to be creative about how to interconnect everything, and how to place everything so that we could minimize size without affecting performance or endangering the circuitry/user.

I found this project course challenging but exciting. I really enjoyed the fact that my team and I started with a simple idea, which turned into a working project in about three and a half months. I found that the weekly meetings we were forced to have with the TA were quite useless, mainly because my group and I had meetings on a daily basis anyways.

Planning ahead was definitely important in this project because nothing goes right the first time around. So you have to give yourself room to work, or else you will fall much too far behind. Also, we found that breaking off into two smaller groups also helped with certain parts of the project (like programming and construction). Working among a group of four friends was quite nice, and I do not think we had any real problems. We just had scheduling problems, because I liked to work in the evening, whereas two members like to work during the morning. But, this scheduling conflict did not matter much when we broke off into smaller groups to work on different parts of the project. The scheduling problems were more of an issue at the start of the project, when we all had to figure out what we were doing first, but once that was settled, scheduling did not matter much (mainly because we had to live at school basically!)



## 6.2 David Black

Of my entire undergrad curriculum, ENSC 440 has surely been the most valuable course. It seems odd to say this – the teachers did not teach anything. Instead, we were left to our own devices and methods to complete the project. Learning's of the past four years culminated and exponentially grew throughout the project execution. While the project was trying and frustrating at times, not to mention extremely time consuming, every moment spent on it was very valuable. Not only was I able to develop on my technical skills, but I was also strengthened my time management and interpersonal skills.

The most valuable aspect of the project came from the work I did with the PIC microcontroller. Prior to this project, I had no experience with microcontrollers - this project forced me to quickly overcome the relatively steep learning curve that is required to implement them in a project. I now consider myself quite knowledgeable with them. I was able to use many features of the PIC, including analog to digital conversion, pulse width modulation, input and output, EEPROM, and clock timing. In the end, I contributed to the implementation of a complete user interface, a control algorithm for temperature control, and a temperature sensor system. Other technical skills that I picked up include PCB design in Eagle, PCB construction, and overall system design.

An unexpected lesson learned during the project execution was the amount of time that it takes to get the ball rolling. Significant time was spent designing and redesigning the system. To add to this, our system was rather large and required numerous components from various sources. The amount of time that was required to hunt down and purchase these parts was quite surprising. If I were to work on a project such as this again, I would ensure that design and part selection get pushed to the forefront during the initial stages of the project. If they are not, delays can be expected.

Throughout the project, each group member had conflicting views on the way certain problems should be solved. In the end, we were able to find a common ground, and the project proceeded in a smooth manner. Although many parts of the project were delayed and we had to work extremely hard towards the end of the term, we managed to complete the project and produce an impressive working prototype. I have been fortunate to work with such a determined and talented group and would gladly look forward to working on any project with them again.

## 6.3 Sal Daswani

The past four months have been an exciting challenge. Not only have I been able to learn a variety of technical information, but I have also learned much about the benefits of working in a group. Our group consisted of four people with vastly different knowledge and experiences. Each member brought a unique contribution to the team. I found that by combining skill sets much more got accomplished than would have otherwise. However, when two people have different opinions and both are potentially valid, having a group actually slowed down the development of the project. However, I feel that the pros of group work definitely outweighed the cons for ThermaCool.

Technically, I became very familiar with how to make my own PCB boards. Instead of outsourcing the boards for the TEC drivers, we decided to produce PCBs ourselves. We

used photosensitive copper, a transparency of our board layout, and ferric chloride etchant to create the copper traces. After tinning the entire board, we proceeded to solder on the various components and check for continuity. The boards worked almost perfectly, with very little debugging needed.

Furthermore, I learned how a Wheatstone bridge circuit with a thermistor as one leg can be used to measure temperature. Even though we did not use a Wheatstone bridge circuit in our project I had to investigate the advantages and disadvantages of such a circuit compared to a voltage divider circuit. Regardless of the fact that the circuit is not particularly complicated, I feel the knowledge gained will help me in my future endeavors.

As well, I learned about the PIC family of microcontrollers, and particularly about the ADCs internal to these microcontrollers. I learned how to calculate the resolution of an ADC, and also about the problem of aliasing. Although we did not program in assembly, I learned a little bit about the assembly code that can be used to program the PIC family of microcontrollers, before we decided to use C code.

I feel that one of the most important things I learned from helping create the Perfect Balance Mattress Pad was the importance of making sure that all hardware components are compatible with each other. Sourcing parts was a large part of the project work, and this was something that I had not done previously.

If there is one thing I could change about the way ENSC 440 is run, I would say that there should be no weekly meetings. I did not find the meetings useful, and would rather have a TA to ask questions to if I need to. However, overall, I would say that creating the Perfect Balance Mattress Pad has been a positive experience, and I look forward to sleeping on it in the future.

## **6.4 Sean Pallister**

ENSC 440 has been by far the most fun course that I have taken throughout my engineering curriculum. Unfortunately, it is not often in Engineering Science when one is given the opportunity to let his/her creativity run wild and engineer a functioning project. I am grateful that I was in a group of hard-working and motivated team members. I think that we had great team dynamics, because we were able to speak our minds to one another without creating any tension. The ability to speak what's really on one's mind with other team members is definitely key to the ultimate success of a project, because in the end there are no regrets.

Throughout this project I was the lead firmware designer. Ever since my first computer programming course at SFU, I have found that I have a knack for coding. However, up until this project, I had never programmed a microcontroller and wasn't sure how well it would go. Actually to be honest, I figured that it would be an absolute horror show at first, but then progress into an easy and enjoyable task. This definitely turned out to be the case, as the process of getting acquainted with the PIC IDE and C18 compiler was riddled with silly mistakes and wasted time. Furthermore, it was necessary to do a whole lot of datasheet research in order to understand how to set the bits here and the bits there to make everything work as desired. However, once I was comfortable with PIC programming, it

was an easy task to make modifications to code and enhance the capability of our system as a whole.

From working on this project, I have gained a lot of valuable firmware design experience. I learned how to work with interrupts, timers, Analog to Digital Converters (ADCs), EEPROM management, Serial Peripheral Interface (SPI) communication and Pulse-Width-Modulated (PWM) signal outputs. I have also learned a great deal about PWM-controlled H-bridges required for controlling dual polarity devices. In our case, we required the dual polarity ability of the H-bridge to reverse the flow of current through our TECs in order to heat in addition to cool. However, this knowledge can now be directly applied to much more common devices requiring dual polarity such as DC motors. In addition to my firmware design experience, I was able to build upon my CAD/CAM experience through the design of the Perfect Balance mattress pad's famous control unit! Dave and I took ENSC 489 (where you learn how to use the CNC milling machines in the lab) and insisted that we set out to design a professional-looking remote control to serve as the front end of our system. So we went ahead and designed our remote control in SolidWorks and milled it out using the Roland CNC machine. Then I went through a painstaking process of creating a label for the front cover of the control unit, but in the end, it received a lot of compliments which is what we were going for.

Now that ENSC 440 is all over, I have to admit that I feel kind of disappointed. I really enjoyed working with all the guys in my group, was really impressed with the work that they put out, and had a lot of fun in the process. Now that the project's over though, there's no more fun to be had such as late nights in the lab trying to debug a circuit and eventually finding out that the problem was some mysterious three foot wire with only one end in the breadboard. However, I guess more fun can be had if this project is taken to the next level, and marketed as a consumer product.

## **7 ACKNOWLEDGMENTS**

We would like to thank the following people for their contributions to the Perfect Balance Mattress Pad.

<i>David Fletcher</i>	Thank you for providing us with our mattress pad and tubing free of charge
<i>Rahm Lavon</i>	Thank you for providing us with various electronic components as well as sharing your knowledge about these components
<i>Nakul Verma</i>	Thank you for helping us throughout our entire project, including helping us with the design of the TEC drivers

## 8 CONCLUSION

The past semester has been a demanding yet rewarding experience for the members of the ThermaCool team. We faced an enormous challenge to design, implement, and document an extremely complex system within tight budgetary and time constraints. In the end, our dedication paid off, and we produced an impressive working prototype of a heating/cooling temperature controlled mattress pad.

This fresh, unique product has the potential to spawn a new market at the consumer level. Each of us is proud of our achievement and thankful for the valuable learning experience had during the execution of the project.



*"Success!"*



## 9 SOURCES AND REFERENCES

- [1] ThermaCool Inc., "Functional Specifications for a Temperature Controlled Mattress Pad," February 2005.