



# Smart Traffic Light (STL)

By AnoLED Technology Inc.

Jan. 25, 2008

## OUTLINE OF PRESENTATION

- Introduction
- System Design
- Challenges
- System Features
- Future Developments
- Timeline and Budget
- Acknowledgment
- Summary
- Questions

# Introduction

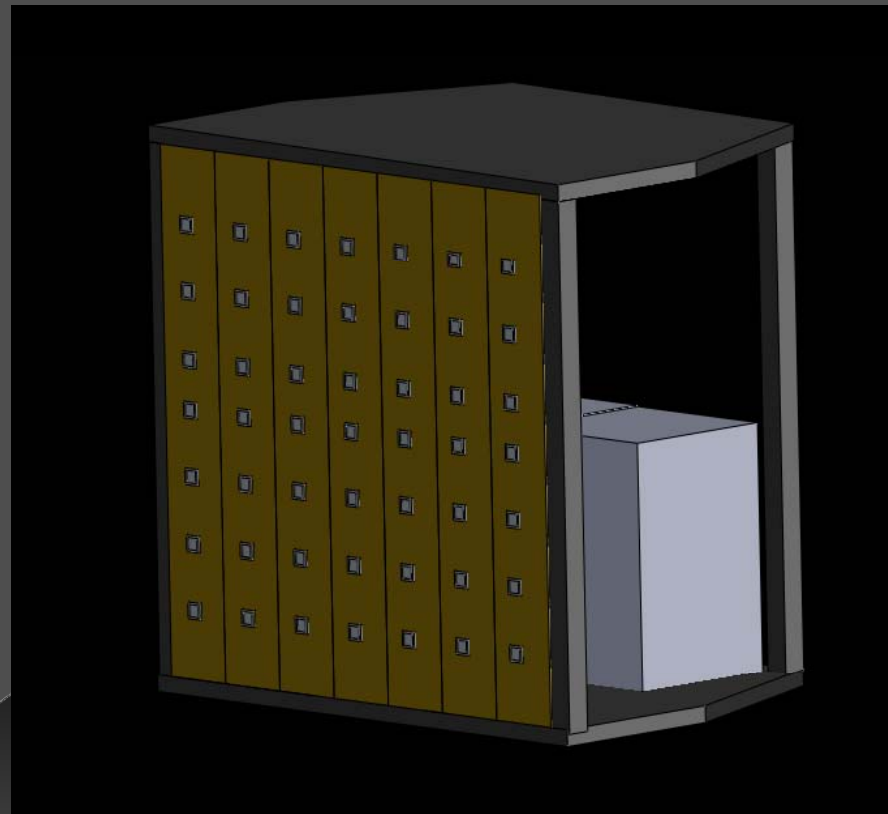

# AnoLED Technology Team

- ◉ Ighodalo Iyayi – CEO
- ◉ Jamal Bahari – CTO
- ◉ Behrad Kajbafzadeh – CFO
- ◉ Sara Rokni – CSA



# Background

- Road crashes cost the Canadian health care system \$10 billion
- Result in nearly 3,000 fatalities and
- One injury for every 135 citizens (2001)

# The Glare Effect

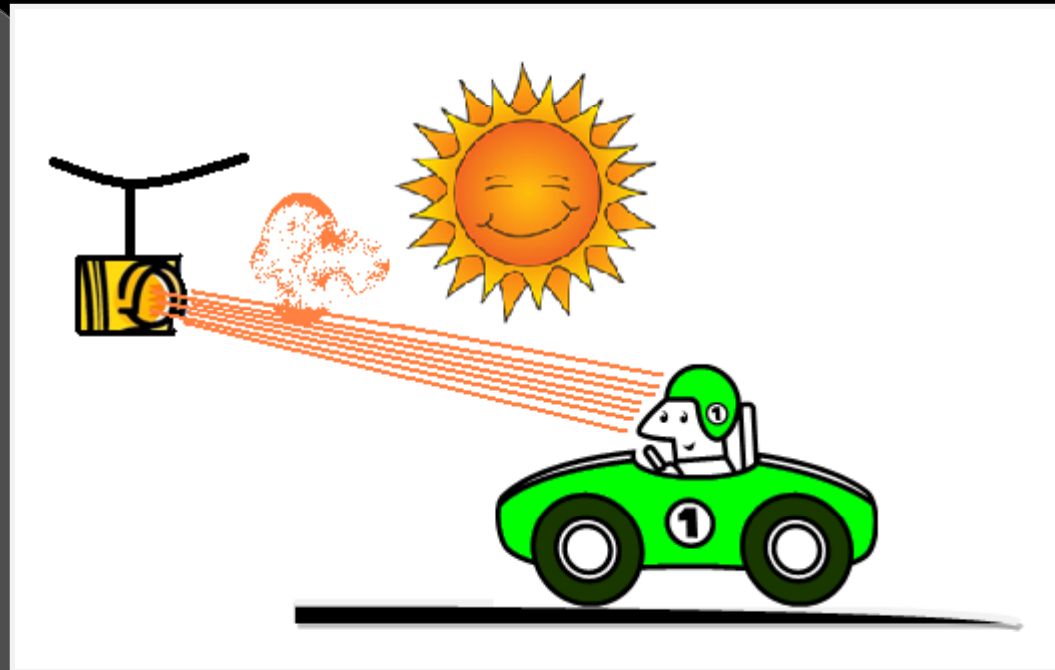

Glare was the official cause of 195 in 56,793 fatal accidents in the US (1999)

# The Fog Effect



Figure 1: Injury and Fatal Crashes in Adverse Weather by Year (2001)

# The Smart Traffic Light





# Conventional Traffic Lights



# Traffic Symbols

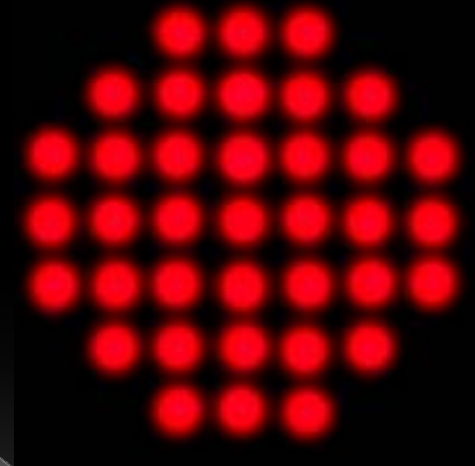
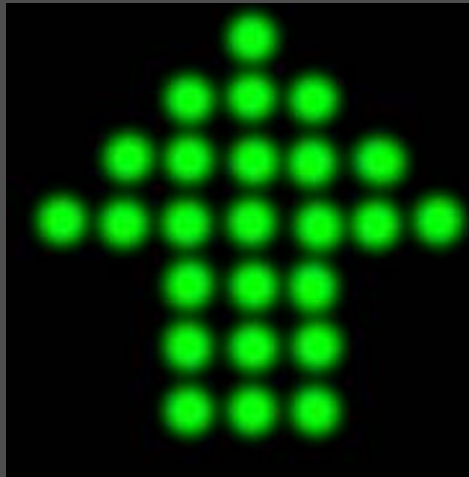

# System Overview

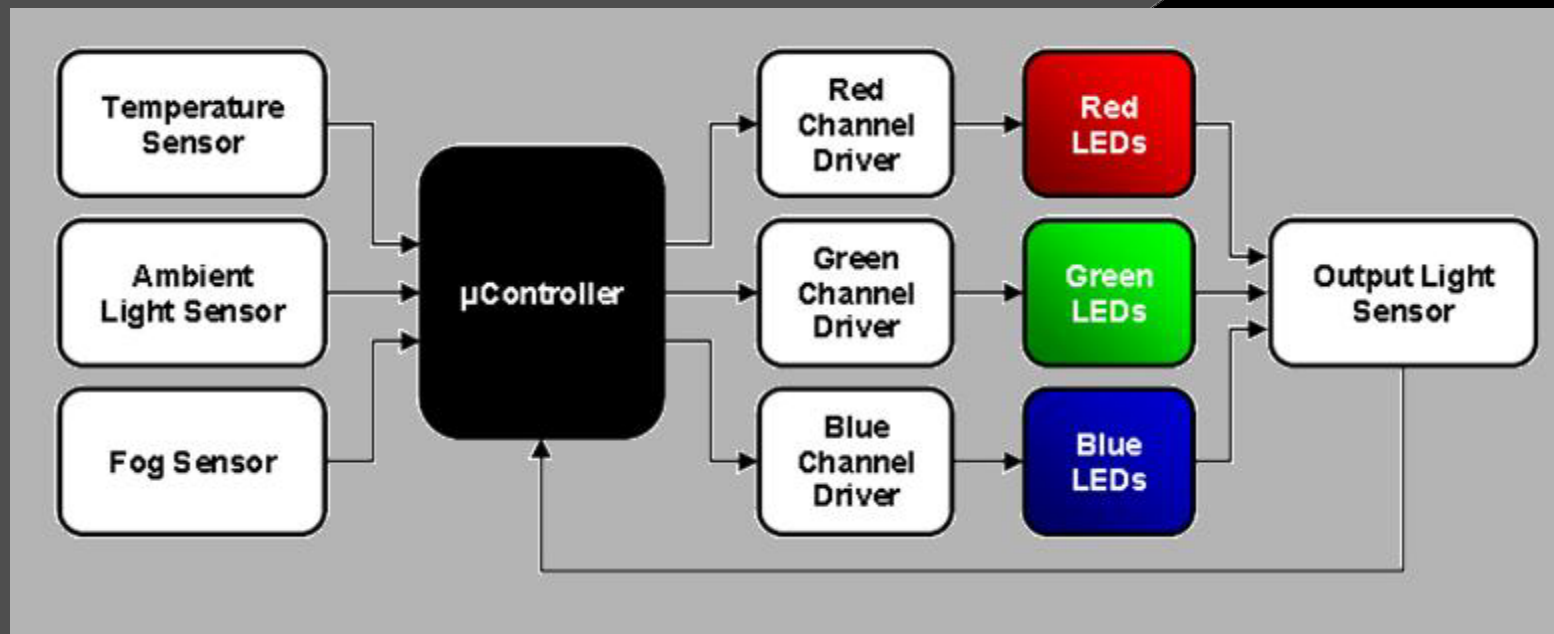

A general overview of STL

# LED Boards

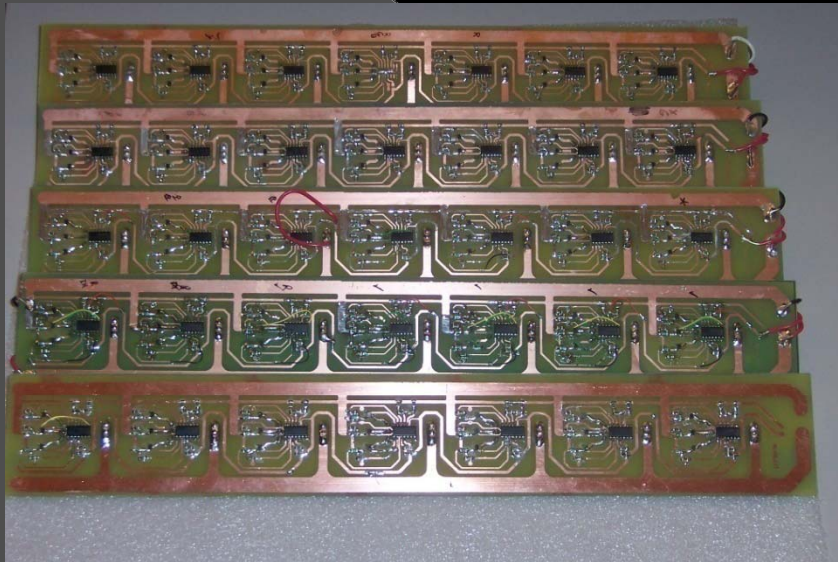

LED Boards for 49 LEDs

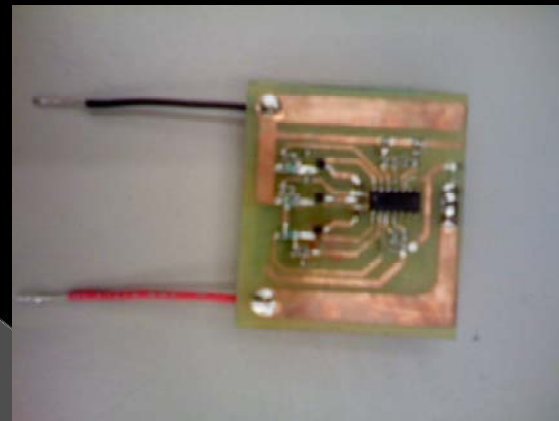

Single LED Board

# Sensors



STL's Fog System

# Challenges

- Hardware
- Software
- Integration



# System Features

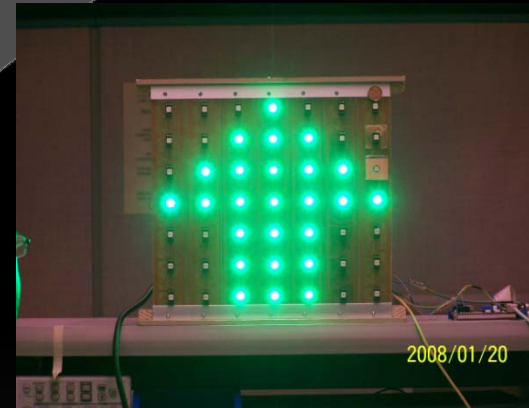
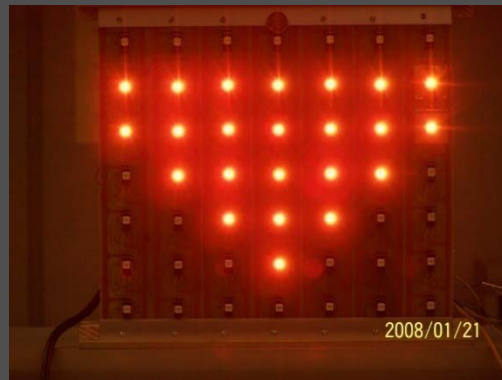
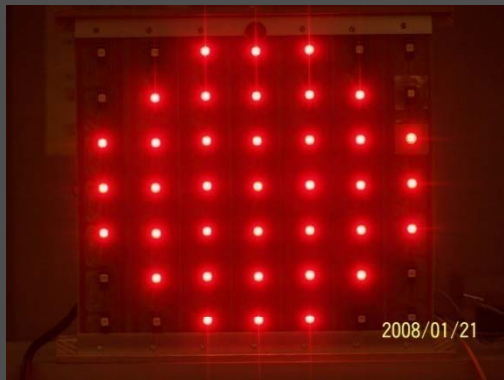

# System Design

- Versatile
- Easily programmable
- Various Applications



# Automobile Lighting



**A**nOLED

# Medical Lighting



**A**nOLED

# Future Developments

- LEDs
- Power Supply
- Fog System
- Enclosure

# Timeline and Budget

- Gantt chart
- Funding/Budget

# Timeline

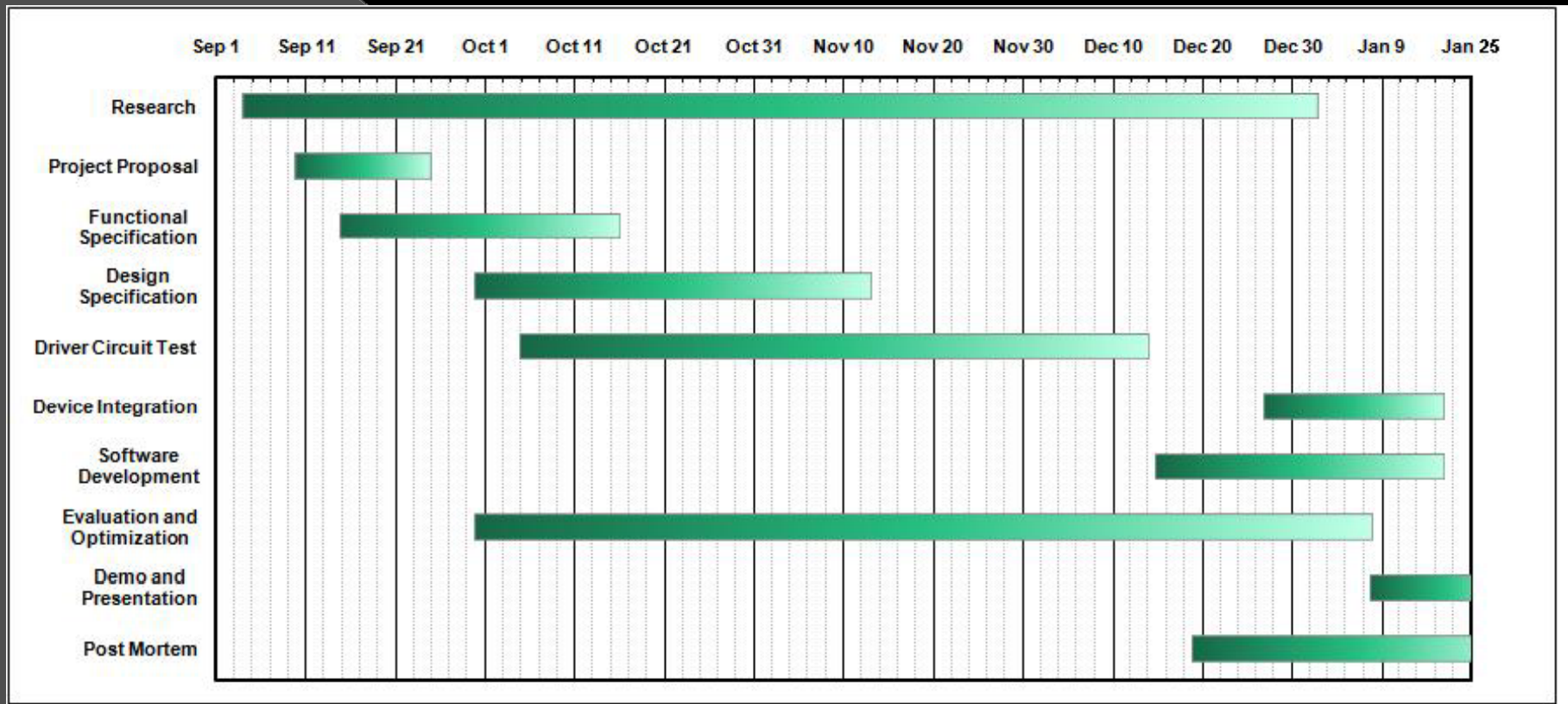

# Budget and Actual Costs

Items	Cost
Lighting	\$323.40
Sensors	\$36.91
Controller Unit	\$0.00
Enclosure	\$17.94
Circuitry	\$357.00
Research Components	\$87.07
Demo Components	\$60.00
Tools	\$80.00
Contingency	\$53.44
Total (Tax & S/H Inc.)	\$1120.0

# Real Cost of the Device

Items	Cost
Lighting	\$200.00
Sensory	\$25.00
Circuitry	\$200.00
Controller Unit	\$10.00
Enclosure	\$5.00
Total	\$440.00

# Acknowledgment

ESSS

Ivan Tomas (Philips Canada)

Dr. Andrew Rawicz

Mike Sjoerdsma

Brad Oldham

Lisette Paris Shaadi

Fred Heep

Marius Haiducu

Gary Houghton

Gary Schum

Alireza Nematollahi

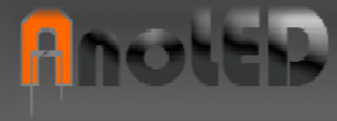



# Conclusion/ Summary

- What we learnt?
  - Technical
  - Non-Technical
    - Group Dynamics
    - Organization
    - Problem Solving

# Questions

? ? ? ? ?  
? ? ? ? ?