



Smart
Buy 

Presents

ADVANCED SHOPPING CART (ASC)

Our Crew

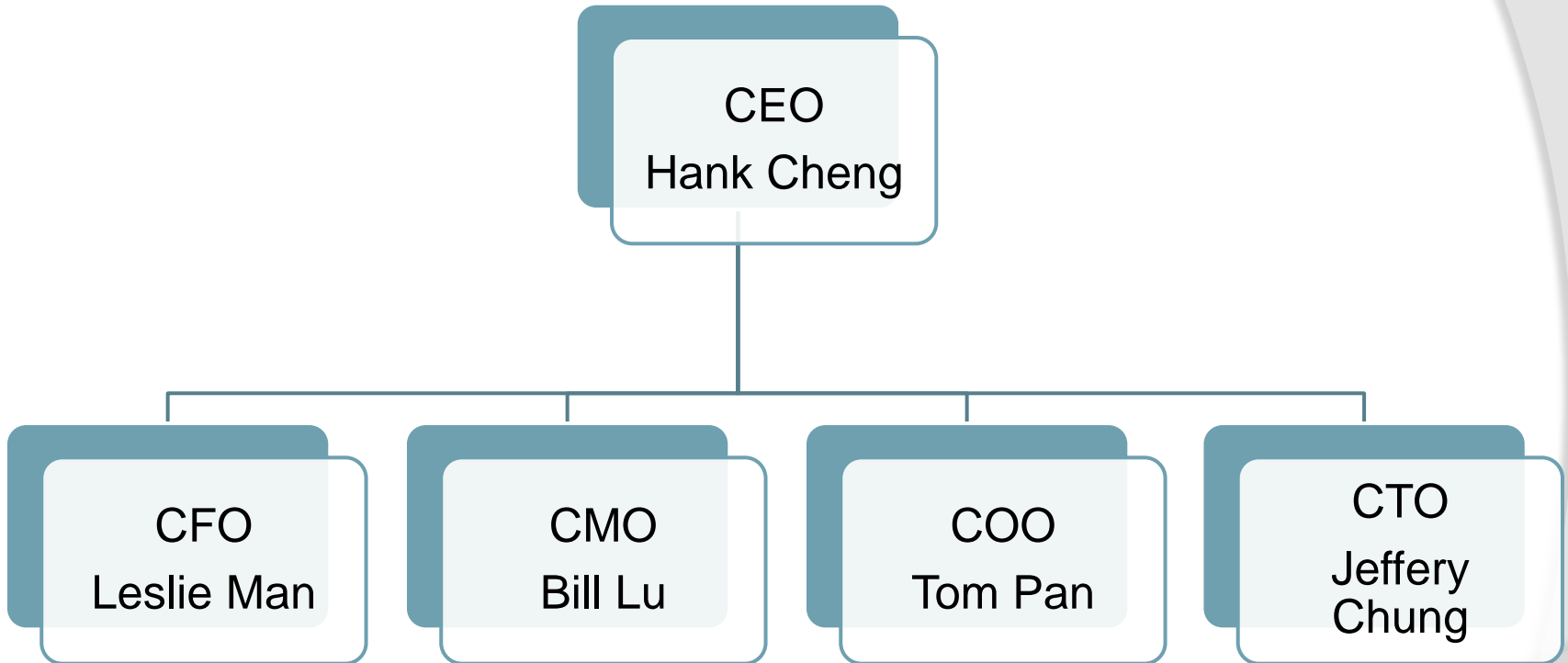

Outline

- **Product Overview**
- System Overview
- Hardware – Tablet
- Hardware – Mount
- Hardware – Security System
- Software
- Business Aspect
- Complications
- Timeline
- Future Development
- Conclusion

Existing Solutions

- Self Checkout Machine
- Ordering Online



Self Checkout



Online Cart

- All of them are not very user friendly

Product

- Advanced Shopping Cart
 - RFID Reader
 - Tablet
- Automatically scan

Benefits

- User Friendly
 - Automatically scan
 - Easy to use interface

- Decrease
 - Line up time
 - Price lookup & calculate time

Outline

- Product Overview
- **System Overview**
- Hardware – Tablet
- Hardware – Mount
- Hardware – Security System
- Software
- Business Aspect
- Complications
- Timeline
- Future Development
- Conclusion

System Overview

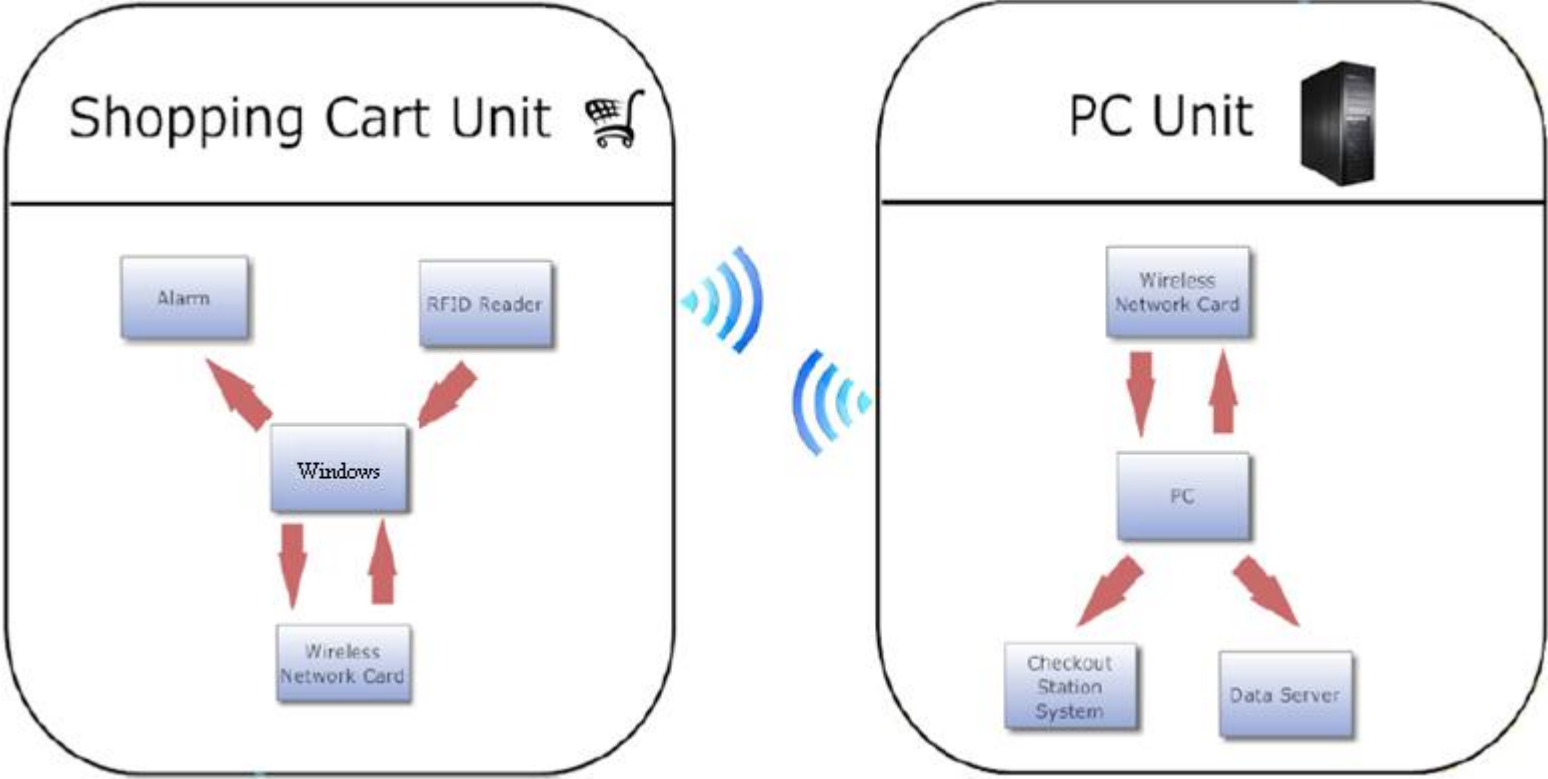

Outline

- Product Overview
- System Overview
- **Hardware – Tablet**
- Hardware – Mount
- Hardware – Security System
- Software
- Business Aspect
- Complications
- Timeline
- Future Development
- Conclusion

Features

- User friendly
- Browser category search
- Show promotional advertisement
- Apply discount automatically
- Show purchases amount before and after taxes
- Easy checkout

Outline

- Product Overview
- System Overview
- Hardware – Tablet
- **Hardware – Mount**
- Hardware – Security System
- Software
- Business Aspect
- Complications
- Timeline
- Future Development
- Conclusion

Mount

- Safely secure tablet
- Tablet mobility
 - Different viewing angles
 - Portable

Picture of mount

➤ Dimension

Tablet Mount Dimension

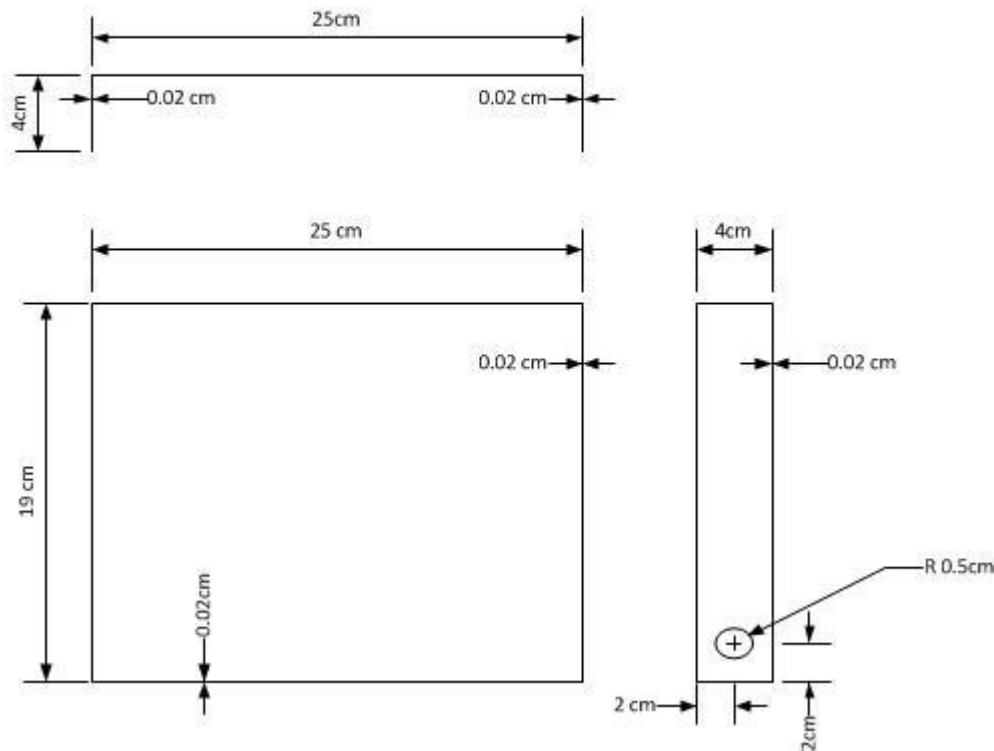

Outline

- Product Overview
- System Overview
- Hardware – Tablet
- Hardware – mount, alarm
- **Hardware – Security System**
- Software
- Business Aspect
- Complications
- Timeline
- Future Development
- Conclusion

Siren Alarm

Siren Alarm System

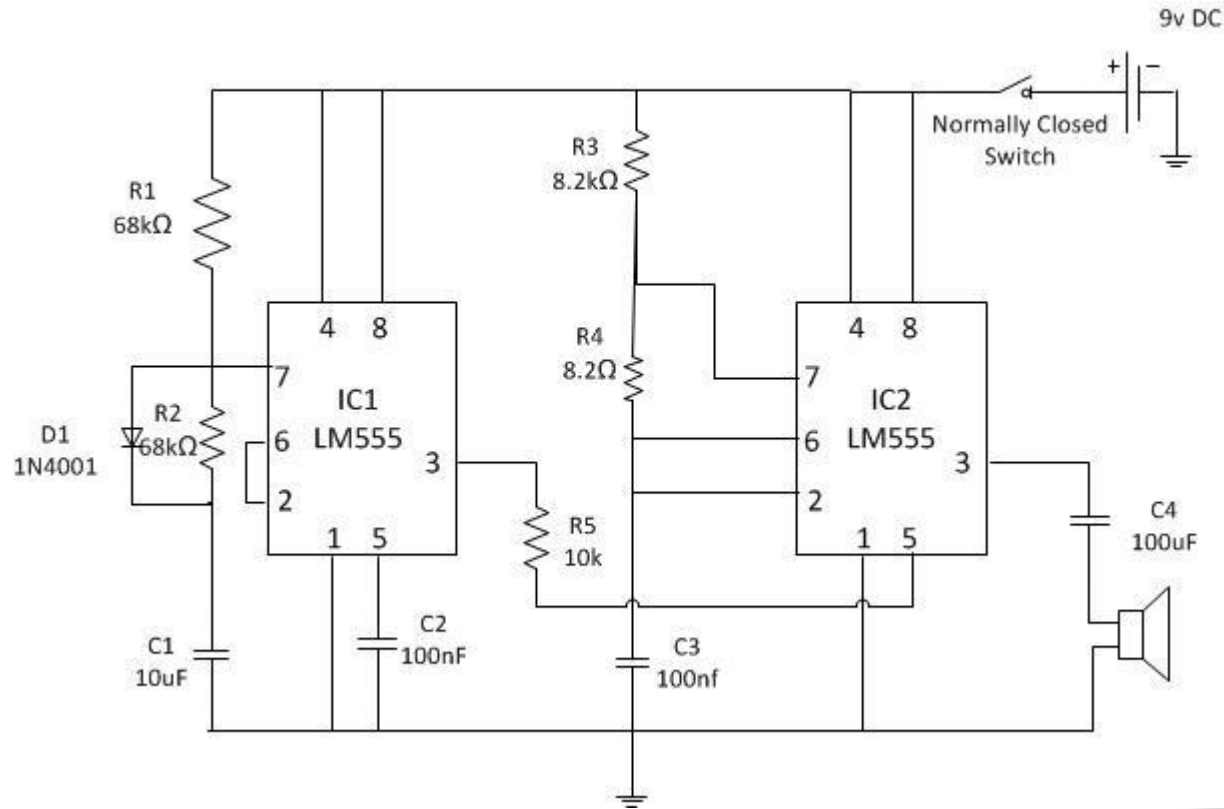

Siren Alarm cont.

- Consist of two 555 timer
- Operating as astable multivibrator
- Output frequency change between 1.4kHz and 2.6kHz
- Producing an siren sound
- Magnetic switch detect tablet stealing
- Key on/off switch to close off the circuit

Central Alarm

- Detects missing product
 - Attempt to steal
 - Alarm will be triggered

Outline

- Product Overview
- System Overview
- Hardware – Tablet
- Hardware – Mount
- Hardware – Security System
- **Software**
- Business Aspect
- Complications
- Timeline
- Future Development
- Conclusion

PC Database & UI

- For employee use only
- File data manipulation and UI using Java SE coding
- NetBeans IDE with Swing GUI builder
- Real-time message passing with Tablet

Database

- For employee use only
- Inventory Information
- Name
- Price
- Description
- Picture (.jpg)
- RF tag IDs
- Stock availability

PC UI

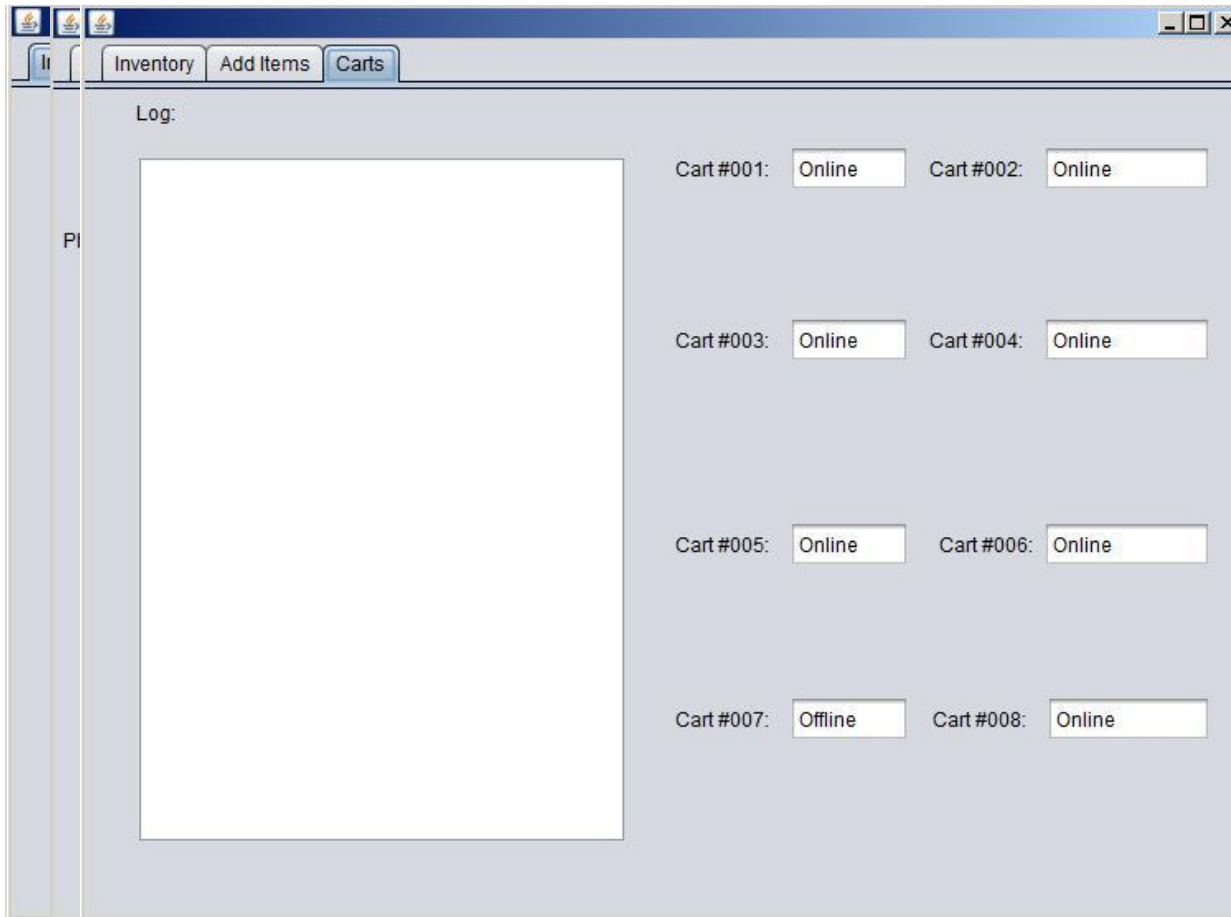

Tablet UI



INC	Product	Price
1	naturSource Decorative Gourmet 4-tray Ensemble	89.99
2	Sanyo Eneloop 1500 Battery Pack 12 AAA Batteries	32.99
	OtterBoxR Defender for Blackberry Curve 9360	47.99
	SanDisk Ultra Backup USB Flash Drive 64 GB	119.99
	Hilroy StudioR Scrap Book	2.99

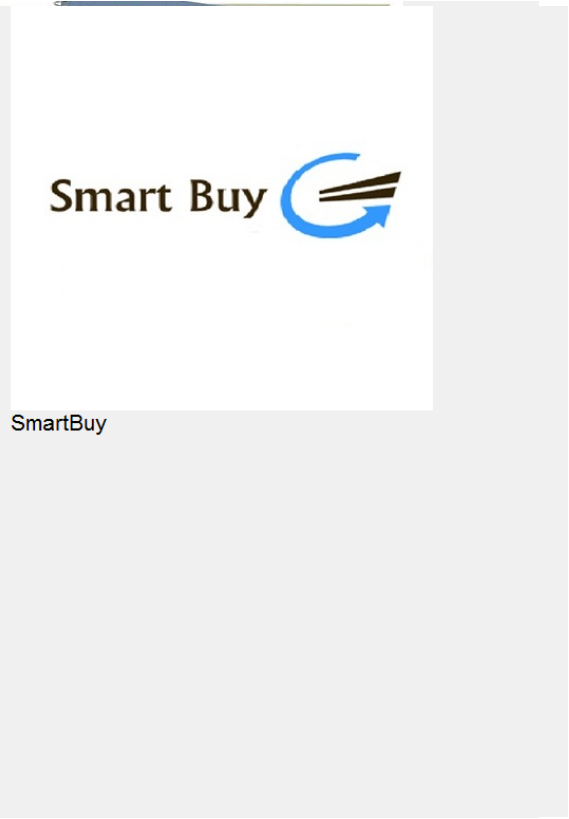

S
T
T

Outline

- Product Overview
- System Overview
- Hardware – Tablet
- Hardware – Mount
- Hardware – Security System
- Software
- **Business Aspect**
- Complications
- Timeline
- Future Development
- Conclusion

Prototype Cost

	Unit Cost
sheet metal	\$13.43
Prototype board	\$4.47
key switch	\$7.34
magnetic switch	\$7.39
UHF RFID	\$431.43
touch screen	\$89.6
spray paint	\$6.43
Total	\$560.08

Sales Strategy

- Pricing
 - \$700/cart
 - \$70,000 per system

Comparison



Superstore				
Days	Counter	Wages	Hours	Total Wage
365	8	\$12	17	\$595680
Using our ASC				
365	2	\$12	17	\$148920
Superstore				
#of shopping cart	cost	cart cost	system	maintance
0	0	0	0	0
Using our ASC				
100	\$700	\$70000	\$70000	\$365000
Superstore				
Revenue from sales	product lost	total Profit	Profit gain	percentage gain
\$18250000	\$456250	\$17198070		
Using our ASC				
\$20075000	\$200750	\$19220330	\$2022260	11.76%

Comparison 2



Costco					
Days	Counter	Wages	Hours	Total Wage	
365	10	\$12	9.714286	\$425485.71	
Using our ASC					
365	2	\$12	9.714286	\$85097.143	
Costco					
# of shopping cart	cost	cart cost	system	maintance	
0	0	0	0	0	
Using our ASC					
100	\$700	\$70000	\$70000	\$365000	
Costco					
Revenue from sales	product lost	total Profit	Profit gain	percentage gain	
\$35040000	\$1051200	\$33563314.3			
Using our ASC					
3\$8544000	\$385440	\$37568462.9	\$4005148.571	11.93%	

Financial Forecast

- Breakeven point
 - \$70,000 salary
 - \$30,000 rent/yr
 - \$84,000 profit per store
 - After selling to 5 stores

Outline

- Product Overview
- System Overview
- Hardware – Tablet
- Hardware – Mount
- Hardware – Security System
- Software
- Business Aspect
- **Complications**
- Timeline
- Future Development
- Conclusion

Complications

- Mount adjustable
 - Unable to modify cart
 - Made tablet moveable 30degree
- RFID reader
 - The first bought does not read multi-tags
 - Reader sensitivity and reliability

Outline

- Product Overview
- System Overview
- Hardware – Tablet
- Hardware – Mount
- Hardware – Security System
- Software
- Business Aspect
- Complications
- **Timeline**
- Future Development
- Conclusion

Outline

- Product Overview
- System Overview
- Hardware – Tablet
- Hardware – Mount
- Hardware – Security System
- Software
- Business Aspect
- Complications
- Timeline
- **Future Development**
- Conclusion

Future Development

- ASC
 - Create a product series
 - Rail on mount
 - Bluetooth Adapter
 - Indoor GPS Guidance
 - Upgrade Central Security System
 - Upgrade RFID Reader

Outline

- Product Overview
- System Overview
- Hardware – Tablet
- Hardware – Mount
- Hardware – Security System
- Software
- Business Aspect
- Complications
- Timeline
- Future Development
- **Conclusion**

What We Learned

- Technical Skills
 - Mechanical Skills
 - Programming Skills
 - Electronic Skills
 - Design
 - Installation
- Non – Technical Skills
 - Communication
 - Project Management

Conclusion

- ASC is a convenient and easy to use
- Great money making product for companies
- No more hassle during line up
- much cheaper if massively produce
- A desired product after price of production goes down

Questions

