

CANADIAN THESES ON MICROFICHE

THÈSES CANADIENNES SUR MICROFICHE



National Library of Canada
Collections Development Branch

Canadian Theses on
Microfiche Service

Ottawa, Canada
K1A 0N4

Bibliothèque nationale du Canada
Direction du développement des collections

Service des thèses canadiennes
sur microfiche

NOTICE

The quality of this microfiche is heavily dependent upon the quality of the original thesis submitted for microfilming. Every effort has been made to ensure the highest quality of reproduction possible.

If pages are missing, contact the university which granted the degree.

Some pages may have indistinct print especially if the original pages were typed with a poor typewriter ribbon or if the university sent us an inferior photocopy.

Previously copyrighted materials (journal articles, published tests, etc.) are not filmed.

Reproduction in full or in part of this film is governed by the Canadian Copyright Act, R.S.C. 1970, c. C-30. Please read the authorization forms which accompany this thesis.

THIS DISSERTATION
HAS BEEN MICROFILMED
EXACTLY AS RECEIVED

AVIS

La qualité de cette microfiche dépend grandement de la qualité de la thèse soumise au microfilmage. Nous avons tout fait pour assurer une qualité supérieure de reproduction.

S'il manque des pages, veuillez communiquer avec l'université qui a conféré le grade.

La qualité d'impression de certaines pages peut laisser à désirer, surtout si les pages originales ont été dactylographiées à l'aide d'un ruban usé ou si l'université nous a fait parvenir une photocopie de qualité inférieure.

Les documents qui font déjà l'objet d'un droit d'auteur (articles de revue, examens publiés, etc.) ne sont pas microfilmés.

La reproduction, même partielle, de ce microfilm est soumise à la Loi canadienne sur le droit d'auteur, SRC 1970, c. C-30. Veuillez prendre connaissance des formules d'autorisation qui accompagnent cette thèse.

LA THÈSE A ÉTÉ
MICROFILMÉE TELLE QUE
NOUS L'AVONS REÇUE

Canada

35-20330-X



National Library of Canada

Bibliothèque nationale du Canada

CANADIAN THESES ON MICROFICHE

THÈSES CANADIENNES SUR MICROFICHE

6824

NAME OF AUTHOR / NOM DE L'AUTEUR James Alan Davis

TITLE OF THESIS / TITRE DE LA THÈSE An Exploration of Psychophysiological Responses to

Acute Alcohol Consumption.

UNIVERSITY / UNIVERSITÉ Simon Fraser University

DEGREE FOR WHICH THESIS WAS PRESENTED /
GRADE POUR LEQUEL CETTE THÈSE FUT PRÉSENTÉE Bachelor of Arts

YEAR THIS DEGREE CONFERRED / ANNÉE D'OBTENTION DE CE GRADE 1964

NAME OF SUPERVISOR / NOM DU DIRECTEUR DE THÈSE Dr. Christopher A. Davis

Permission is hereby granted to the NATIONAL LIBRARY OF CANADA to microfilm this thesis and to lend or sell copies of the film.

L'autorisation est, par la présente, accordée à la BIBLIOTHÈQUE NATIONALE DU CANADA de microfilmer cette thèse et de prêter ou de vendre des exemplaires du film.

The author reserves other publication rights, and neither the thesis nor extensive extracts from it may be printed or otherwise reproduced without the author's written permission.

L'auteur se réserve les autres droits de publication; ni la thèse ni de longs extraits de celle-ci ne doivent être imprimés ou autrement reproduits sans l'autorisation écrite de l'auteur.

DATED / DATE Dec 17/84 SIGNED / SIGNÉ _____

PERMANENT ADDRESS / RÉSIDENCE FIXE _____

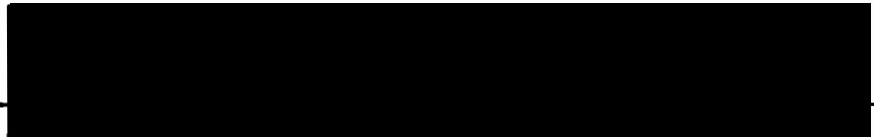

AN EXPLORATION OF PSYCHOPHYSIOLOGICAL RESPONSES TO RHYTHMIC
AUDITORY STIMULATION

↑
by

Douglas Owen Cheyne

B.Sc., University of Waterloo, 1981

THIS THESIS SUBMITTED IN PARTIAL FULFILLMENT OF
THE REQUIREMENTS FOR THE DEGREE OF
MASTER OF ARTS
in the Department
of
Psychology

© Douglas Owen Cheyne 1984

SIMON FRASER UNIVERSITY

November, 1984

All rights reserved. This work may not be
reproduced in whole or in part, by photocopy
or other means, without permission of the author.

APPROVAL

NAME: Douglas Owen Cheyne

DEGREE: Master of Arts

TITLE OF THESIS: An Exploration of Psychophysiological
Responses to Rhythmic Auditory Stimulation

EXAMINING COMMITTEE:

Chairperson: Dr. Vito Modigliani

Dr. Christopher Davis

~~Dr. Harold Weinberg~~

Dr. Martin Laba
External Examiner
Department of Communications
Simon Fraser University

Date approved: November 30, 1984

PARTIAL COPYRIGHT LICENSE

I hereby grant to Simon Fraser University the right to lend my thesis, project or extended essay (the title of which is shown below) to users of the Simon Fraser University Library, and to make partial or single copies only for such users or in response to a request from the library of any other university, or other educational institution, on its own behalf or for one of its users. I further agree that permission for multiple copying of this work for scholarly purposes may be granted by me or the Dean of Graduate Studies. It is understood that copying or publication of this work for financial gain shall not be allowed without my written permission.

Title of Thesis/Project/Extended Essay

An Exploration of Psychophysiological Responses to
Rhythmic Auditory Stimulation.

Author:

(signature)

DOUGLAS O. CHENEY

(name)

Dec. 12 1984

(date)

ABSTRACT

Neher reported in 1962 that rhythmic drumming and other forms of rhythmic stimulation are capable of inducing physiological changes that may be associated with behavioural changes or changes in states of consciousness during ritualistic practices. Subsequent studies have found evidence to both support and refute this hypothesis under various experimental conditions.

This study was conducted in order to determine if recruitment of EEG rhythms could be produced with 'naturalistic' auditory rhythms in a laboratory setting. Four female and four male adult subjects were presented with various forms of naturally occurring rhythmic (tape recorded) auditory stimuli including symphonic music, rhythmic instrumental music, and repetitive drumming sounds for periods of up to three minutes. Monopolar EEG was recorded from the scalp (positions C3, C4, T3, T4, and Oz using the 10-20 system) in addition to heart rate, respiration rate, and bilateral hand movements. Photic flashes were also presented to two subjects, and two subjects were instructed to tap either hand to rhythmic drumming sounds.

Frequency analysis (FFT) of the EEG data showed no evidence of increased magnitude of the stimulus frequency during auditory stimulation but did indicate increased magnitude at the stimulus frequency during photic stimulation. No consistent changes in respiration or heart rate were noted across the auditory conditions although differences were noted between auditory and

photic stimulation. EMG responses indicated slight differences in resting activity in contralateral limbs before and during tapping movements. Since no auditory driving was achieved no comparisons could be made between EEG and peripheral responses with respect to the frequency of the auditory stimulus.

It was concluded that overt auditory driving of the EEG cannot be readily produced in a laboratory situation although photic driving responses were produced under conditions in which auditory driving responses were not produced. Although auditory driving responses may be correlated with behavioural changes as indicated by Neher, photic driving can be observed in the absence of such changes and may therefore constitute a different phenomenon physiologically than auditory driving. Difficulties in measuring such responses in a laboratory setting were noted and suggestions for further research on auditory driving are given.

ACKNOWLEDGEMENTS

This thesis could not have been completed without the help and suggestions of many friends and colleagues.

I must express my gratitude to the members of my advisory committee, Chris Davis and Hal Weinberg, for their support and suggestions over the course of the project and would also like to thank Martin Laba for his insightful comments and careful reading of the thesis.

I owe a great deal of thanks to Howard Gabert for his help and advice (and for endless discussions on FFT's) and to Malcolm Toms, Wayne Tressel and other members of the technical and support staff at Simon Fraser for their help throughout the project.

I would also like to thank Kurtis Vanel for his expert help with the sound tapes, and to Albert St. Albert for graciously providing his musical talents for the taping of the conga drum.

A great deal of appreciation is also owed to all those people who provided their help and suggestions throughout - Carol Barker, Tom Zerucha, Nancy Higgins, Sandra Murray, Dr. Paul Brickett, and Dr. Len Diamond, to name only a few.

Of course, special thanks go to Chris Davis for his advice and enthusiasm for the thesis project and for his support throughout my time spent here at Simon Fraser.

TABLE OF CONTENTS

Approvalii

Abstractiii

Acknowledgementsv

List of Figuresviii

A. Introduction1

 I. Theoretical Background2

 Previous Research2

 Neurophysiological Basis of the Driving Response6

 EEG Driving and States of Consciousness12

 Cognitive Aspects of Repetitive Auditory Stimulation
 and Musical Rhythms18

 Hemispheric Specialization and the Neural Basis of
 Rhythm24

 Approaches to the Study of the Psychophysiology of
 Rhythm26

 II. Present Study29

B. Method31

 Subjects32

 Apparatus and Recording Procedures32

 Testing Procedures37

 Data Analysis37

C. Results40

 EEG Data41

 Respiration Rate65

 Heart Rate65

 EMG Data66

D. Discussion	82
Recommendations for further research	92
Appendix A : Schematic diagram of auditory envelope detector.	94
Appendix B : Plots of EEG data during auditory stimulation ...	95
EEG DURING AUDITORY STIMULATION AT a rate of 3.4 beats/second. (Subject: G. S.)	96
EEG DURING AUDITORY STIMULATION AT a rate of 9.0 beats/second. (Subject: G. S.)	97
EEG DURING AUDITORY STIMULATION AT a rate of 3.4 beats/second. (Subject: D. W.)	98
EEG DURING AUDITORY STIMULATION AT a rate of 9.0 beats/second. (Subject: D. W.)	99
Appendix C : Plots of EEG data during photic stimulation	100
EEG DURING PHOTIC STIMULATION AT a rate of 5.0 flashes/second. (Subject: G. S.)	101
EEG DURING PHOTIC STIMULATION AT a rate of 10.0 flashes/second. (Subject: G. S.)	102
EEG DURING PHOTIC STIMULATION AT a rate of 5.0 flashes/second. (Subject: D. W.)	103
EEG DURING PHOTIC STIMULATION AT a rate of 10.0 flashes/second. (Subject: D. W.)	104
Appendix D : Plots of rectified EMG during auditory stimulation	105
RECTIFIED EMG FOR LEFT AND RIGHT FOREARM PLACEMENTS. SUBJECT LISTENING TO RHYTHMIC SOUND. (Subject: N. H.)	106
RECTIFIED EMG FOR LEFT AND RIGHT FOREARM PLACEMENTS. SUBJECT TAPPING TO RHYTHMIC SOUND. (Subject: N. H.)	107
RECTIFIED EMG FOR LEFT AND RIGHT FOREARM PLACEMENTS. SUBJECT LISTENING TO RHYTHMIC SOUND. (Subject: C. B.)	108
RECTIFIED EMG FOR LEFT AND RIGHT FOREARM PLACEMENTS. SUBJECT TAPPING TO RHYTHMIC SOUND. (Subject: C. B.)	109
Reference Notes	110
References	114

LIST OF FIGURES

FIGURE		PAGE
1	Model of pathways involved in perception and production of auditory rhythms	27
2	Diagram of laboratory layout showing position of subject and apparatus during recording procedure.	34
3-1; 3-2	Average magnitude of EEG frequency components for each electrode placement. Subject G. S.	43, 44
3-3; 3-4	Average magnitude of EEG frequency components for each electrode placement. Subject D. W.	45, 46
3-5; 3-6	Average magnitude of EEG frequency components for each electrode placement. Subject P. R.	47, 48
3-7; 3-8	Average magnitude of EEG frequency components for each electrode placement. Subject K. W.	49, 50
3-9; 3-10	Average magnitude of EEG frequency components for each electrode placement. Subject L. R.	51, 52
3-11; 3-12	Average magnitude of EEG frequency components for each electrode placement. Subject M. G.	53, 54
3-13	Average magnitude of EEG frequency components during photic stimulation. Subject G. S.	55
3-14	Average magnitude of EEG frequency components during photic stimulation. Subject D. W.	56
4-1	Frequency analysis (FFT) of EEG for each electrode placement across conditions. Subject G. S.	57
4-2	Frequency analysis (FFT) of EEG for each electrode placement across conditions. Subject D. W.	58
4-3	Frequency analysis (FFT) of EEG for each electrode placement across conditions. Subject P. R.	59

4-4	Frequency analysis (FFT) of EEG for each electrode placement across conditions. Subject K. W.	60
4-5	Frequency analysis (FFT) of EEG for each electrode placement across conditions. Subject L. R.	61
4-6	Frequency analysis (FFT) of EEG for each electrode placement across conditions. Subject M. G.	62
4-7	Frequency analysis (FFT) of EEG for each electrode placement during photic stimulation. Subject G. S.	63
4-8	Frequency analysis (FFT) of EEG for each electrode placement during photic stimulation. Subject D. W.	64
5-1	Average respiration rate across conditions. Subject G. S.	67
5-2	Average respiration rate across conditions. Subject D. W.	68
5-3	Average respiration rate across conditions. Subject P. R.	69
5-4	Average respiration rate across conditions. Subject K. W.	70
5-5	Average respiration rate across conditions. Subject L. R.	71
5-6	Average respiration rate across conditions. Subject M. G.	72
5-7	Average respiration rate across conditions during photic stimulation. Subject G. S.	73
5-8	Average respiration rate across conditions during photic stimulation. Subject D. W.	74
6-1	Average heart rate across conditions. Subject G. S.	75
6-2	Average heart rate across conditions. Subject D. W.	76
6-3	Average heart rate across conditions. Subject P. R.	77
6-4	Average heart rate across conditions. Subject K. W.	78

6-5	Average heart rate across conditions.....	
	Subject M. G.	79
6-6	Average heart rate across conditions, during photic stimulation. Subject G. S.	80
6-7	Average heart rate across conditions, during photic stimulation. Subject D. W.	81

A. Introduction

I. Theoretical Background

Previous Research

Although photic driving responses can be elicited with consistency in humans using stroboscopic stimulation (Adrian & Matthews, 1934; Walter & Walter, 1949) and have been applied in the diagnosis of various physical pathologies (Hamel et al., 1978; Cohen et al., 1980; Ramani, Torres & Luewenson, 1984) studies of auditory driving have been less successful. Conflicting reports of the ability to elicit rhythmic responses in the EEG synchronous with a repetitive auditory stimulus may be due, not to recording techniques or methods of analysis, but to the types of auditory stimuli used and the manner in which they are presented. Plutchik (1966) was unsuccessful in eliciting a driving response to various frequencies using a tone generator, whereas, Neher (1961) reported the successful elicitation of auditory driving using a drum beat at various frequencies. As will be noted, there are many procedural differences between these two studies which may account for the conflicting results and these will be discussed later. However, Neher makes an important point with regard to the nature of the driving stimulus noting that "natural" auditory stimuli, such as the beating of a drum, would be more likely to elicit a response

due to the presence of harmonics which would increase the "power" of the stimulus and possibly activate a larger portion of the auditory cortex. This early attempt at "ecological validity" in an electrophysiological study may illustrate the possible importance of using naturalistic stimuli and/or settings in these types of experiments. More recent studies have reported the ability to induce rhythmic activity in the EEG using complex (naturally occurring) auditory stimuli such as chanting and rhythmic music (Rogers, 1976; Rogers & Walter, 1982) as well as amplitude modulated white noise (Rodenburg, Verweij, & Van den Brink, 1972). Some early investigators reported driving responses in patients with temporal lobe seizures in a few cases. The difficulty in eliciting driving responses with auditory stimulation has also been attributed to the anatomical position of the primary auditory cortices (infolded within the Sylvian fissures). It is thus debatable as to whether primary cortical responses to sound can be recorded from the scalp even with temporal electrode placements (see Naquet, 1974, p. 30).

With regard to the experimental findings to date, the relative success with which photic driving can be elicited may be attributed to the fact that white light of high intensity is typically used as the eliciting stimulus. This results in a large proportion of fibers being activated throughout the visual system; a system which in humans represents a relatively large amount of ascending fibers and cortex. Similarly, in accordance

with present knowledge of coding in the auditory system (frequency encoding, tonotopic organization of the auditory cortex) stimulation by means of a single frequency tone of moderate intensity would only engage a relatively small proportion of similar components in the auditory system, whereas, a broader range of frequencies would activate a larger area of cortex as is contended by Neher (1962). Studies of the auditory system have shown that stimulus intensity is related to the number of nerve fibers activated although it is not known how this mechanism works with complex sounds and it is even speculated that information regarding sound intensity may be determined during the first few milliseconds and only changes in intensity detected thereafter (Møller, 1983 p.237). However, it is important to note that the temporal response of fibers encoding complex sounds are dominated by frequency components that are large in the stimulus (Sachs, 1984). Also, tonotopic organization of frequency in the human auditory cortex has been demonstrated using intracranial electrodes (Celesia, 1976) and more recently with magnetoencephalographic recordings (Romani, Williamson & Kaufman, 1982). Therefore, the use of either pure tones or complex sounds may be an important factor in understanding the differences observed between photic driving responses and driving in the auditory system.

In addition to the types of sounds employed, the (driving) frequency, duration, and regularity of stimulation may have a significant effect on results. Plutchik, (1966) used pulsed pure

tones presented for 20 second durations and concentrated on responses in the alpha range (since this is the optimal range for photic driving responses). Neher (1961) used drum beats at frequencies between 4 and 7 per second for durations of up to four minutes (Neher's subjects also reported perceptual distortions and mood changes -- Plutchik gives no indication of such effects). Rogers (1976; see also Rogers and Walter, 1982) reports auditory driving to occur maximally in the alpha band even though the auditory signal's maxima were lower (5 - 8 c/sec); however, responses were measured in terms of "coordination" between EEG and auditory signals in an attempt to find single generators of rhythmic brain activity. Some interesting findings reported in Roger's (1976) study include the occurrence of increased power in the theta band (concomitant with a high degree of coordination between EEG signals) for subjects engaged in chanting in contrast to increased activity in the alpha band for the same subjects listening to a recording of the same chanting. Unfortunately, the possibility of muscle artifacts during the chanting condition precluded any definite conclusions from these results.

Rodenberg et al. (1972) used amplitude modulated white noise in order to achieve a response resembling auditory driving using averaged transients. Rodenberg et al. report a maximal averaged evoked response at an amplitude modulation frequency of about 9 c/sec. This study consisted of only two subjects both of which responded to various frequencies between 4 and 11 c/sec.

Cortical responses were also found to be a function of modulation "depth" (modulation amplitude / total amplitude X 100) with a saturation effect at about 25%.

Thus, although there is some evidence for the production of auditory driving of the EEG under certain circumstances, the necessary stimulus parameters have not been well defined.

Neurophysiological Basis of the Driving Response

Spontaneous EEG Rhythms

An adequate description of the neurological basis of rhythmic electrical activity recorded from the scalp has not been provided to date, and many theorists hold contradictory views on the source of generation and significance of consistent rhythms observed in the EEG such as that of the alpha rhythm. Much of the difficulty in the interpretation of scalp-recorded activity is due to the attenuation and distortion of electrical signals originating from the cortex by overlying bone and tissues. It is generally agreed that large amplitude oscillations reflect the summation of post-synaptic potentials (EPSPs and IPSPs) in large populations of neurons -- most likely in the apical dendrites of pyramidal neurons perpendicular to the surface of the cortex (for a review see Creutzfeldt & Houchin, 1974). The extent to which synchrony is exhibited in the EEG must therefore reflect the extent to which large

populations of these neurons are firing in phase. Emphasis has been placed mostly on thalamocortical connections as a possible central generator or "pacemaker" of phasic activity in the cortex (Anderson & Eccles, 1962) although some argue for cortical origin from various sites based on phase reversals observed within the layers of the cortex (Lopes da Silva & Storm van Leeuwen, 1978).

There has been great interest as to whether spontaneous or so-called "resting" rhythms of the EEG, such as alpha and theta rhythms, may reflect the functional state of underlying neural structures. Elul (1972) presents an interesting theory in which short epochs of synchronous EEG activity represents "scanning" of the cortex by subcortical structures where intermittent synchronization of groups of cortical cells by sub-cortical structures resembles selective attention to sensory input. Others have proposed that cortical rhythms may reflect the "filtering" effects of neural systems involved in the selectivity of sensory input, particularly for the visual system (Spekreijse, 1966; Lopes da Silva et al, 1974) and that the modification of filtering characteristics of the cortical network may be involved in learning and memory (Creutzfeldt, 1978).

More recently some theorists have proposed that the electromagnetic oscillations produced by the firing of large populations of neurons (and recorded by the EEG) may themselves provide the medium in which information is encoded in the brain

rather than such information being encoded by specific patterns of neural impulses -- that is, various structures within the brain may be able to communicate with one another via electromagnetic wave patterns which are capable of 'resonating' with each other. These ideas are partly supported by studies in which the application of low frequency electromagnetic fields to the brain in cats and monkeys is claimed to be effective in producing changes in EEG patterns and behaviour (Gavalas et al., 1970; Lawrence & Adey, 1982).

EEG Driving Responses

The relationship between spontaneous rhythmic activity in the EEG and "driven" activity by repetitive sensory stimulation is poorly understood. At low rates of photic stimulation (less than 8 flashes/sec) the EEG signal reveals successive visual evoked potentials but at higher rates a sinusoidal pattern appears that is apparently time-locked to the stimulus. Frequency analysis of the EEG reveals that during rhythmic photic stimulation the FFT spectra also contain 2nd, 3rd, and 4th harmonics of the stimulus frequency which cannot be explained in terms of evoked potentials (Storm van Leeuwen, Lopes da Silva, & Kamp, 1975). Some researchers believe that such driving responses may involve the synchronization or "resonance" of stimulus rhythms with oscillating circuits within the brain -- circuits that are related to spontaneous brain

rhythms -- although some have pointed out difficulties with this view (Regan, 1972, p. 237).

It may be important to distinguish here between brain responses to repetitive stimulation at various levels of sensory systems, such as the ability to produce synchrony or desynchrony in the EEG by direct stimulation of reticular systems of the brain stem (Dempsey & Morrison, 1943; Moruzzi & Magoun, 1948) and those changes observed in electrical activity at the surface of the cortex due to stimuli presented to the subject in the form of tones, beeps, clicks and so on. Furthermore, it must be determined whether one wishes to measure brain stem responses to sounds to which the subject is responding in a passive manner (reflecting activity of ascending auditory pathways) or whether one wishes to measure the subject's active response to rhythmic auditory stimulation which would entail a higher degree of processing. In other words, it is necessary to distinguish large-scale 'driving' responses which can be detected in the continuously recorded EEG and 'frequency following' responses observed in the EEG using steady state averaging techniques². To date, an explanation of cortical driving responses in terms of either activity of ascending sensory pathways or as a reflection of neural events involving information processing has not been provided. Therefore, "driving" of the EEG can be considered to reflect some sort of generalized rhythmic brain activity (similar to that of alpha rhythms) the neurological basis of which is not yet fully understood. However, it can be argued

that sensory driven rhythms would involve large-scale synchronization of underlying neural structures.

It may be important, however, to note some differences found between EEG responses to sinusoidally modulated light (SML) and responses to repetitive flashes. Sinusoidally modulated light was first employed in the investigation of retino-cortical transfer functions (De Lange, 1958; Spekreijse, 1966). Nonlinearities exhibited by these systems were explained in terms of the "selective filtering" properties of the cortex to sensory stimulation. It was found by Townshend, Lubin, and Naitoh (1975) that spontaneous alpha rhythms could be frequency stabilized by SML but not by photic flashes. It was concluded that phase-locking with sub-cortical alpha generators may be achieved with SML at frequencies at or near the resting alpha rate; whereas, repetitive photic flashes reflect successive evoked responses. This is in agreement with earlier findings by Van der Tweel and Verduyn Lunel (1965) that greater cortical responses are obtained with SML near spontaneous alpha rates than at higher frequencies. It is also interesting that responses were also greater for lower modulation depth (less than 50%). This has interesting implications in the study of auditory driving if the same effect is found to hold true for repetitive auditory stimuli. Thus, it may be critical to examine the type of modulation used in auditory driving studies -- naturalistic sounds may represent a more sinusoidally modulated source than pure tones and increase the likelihood of

phase-locking effects with resting cortical rhythms.

It is generally known that synchronization of EEG activity is correlated with the functional state of reticular structures associated with different levels of the waking-sleeping continuum. Less well understood is how afferent stimuli interact with reticular systems. It is also known that responses to repetitive acoustic stimuli are facilitated by stimulation of the reticular formation although interaction between the reticular formation and sensory systems appears to be complex and dependent upon behavioural state (see Steriade, 1970 for review).

With regard to laboratory studies of photic driving there appears to be a strong relationship between maximal driving and the behavioural state of the subject. Maximal driving is often accompanied by reports of emotional changes or perceptual distortions by the subjects (Walter & Walter, 1949; Ulett, 1953; Neher, 1961). Steriade (1962) reported that increased response to rhythmic photic stimulation during arousal was sometimes associated with increased subjective experience. Some researchers have stressed the importance of the functional state of the reticular activating system with regard to individual differences in driving responses (Golubeva, 1972). Various forms of physical stimulation are able to enhance EEG responses to rhythmic stimulation in laboratory studies and include; combinations of different rhythms, tactile stimulation, hyperventilation, hypoglycemia, and administration of

convulsants such as Metrazol (Neher, 1962). It has also been found by this investigator³ that successful elicitation of photic driving in animal preparations may be highly dependent upon the arousal level of the animal. Therefore, it is apparent that EEG responses to sensory stimulation are highly dependent on arousal mechanisms and the effects of stimulation in other sensory modalities.

EEG Driving and States of Consciousness

Most likely we do not respond in the form of cortical driving to the mere presence of repetitive auditory and visual stimulation around us; nevertheless, there can be found many examples of extreme behavioural changes in the presence of rhythmic stimulation, often concomitant with EEG changes. Experimentally, it has been demonstrated that rhythmic visual and auditory stimulation is able to induce altered perceptions or seizure activity in some instances (Walter & Walter, 1949; Loyd-Smith & Henderson, 1951; Goldman, 1952; Ulett, 1953). In addition to this are the many reports of the use of rhythmic chanting, singing, or drumming in various cultures to achieve meditational or hallucinatory states. These examples involve highly complex and differing sets of behaviours, but all have the common feature of using external stimulation of a repetitive or rhythmic nature, often in conjunction with other forms of physical stimulation, in order to achieve behavioural changes.

Considering these two phenomena -- the ability to produce perceptual or behavioural changes in a laboratory setting using rhythmic sensory stimulation and the use of rhythmic stimulation during ritualistic practices which often result in altered mental states -- it would appear that there may be similar physiological processes involved.

The import given to physiological arousal and the notion of "hyperaroused" states in the production of trance-like states or so-called "possession" states is well documented and many authors have proposed the idea of rhythmic stimulation being an important device for producing central nervous system effects associated with such states (Neher, 1962; Sargent, 1964; Prince, 1966; Goodman, 1972; Jilek, 1982). In fact, the relationship between stroboscopic stimulation during stress and "visionary" experiences is recounted as early as 1956 by Aldous Huxley in his descriptions of the effects of hallucinatory drugs on perception (Huxley, 1956). Jilek (1982) has published a review of shamanic ceremonialism among the Pacific Northwest Indians in which he describes the therapeutic effects of ritualistic "spirit dancing". He regards physiological stress, in conjunction with rhythmic auditory stimulation, particularly drumming, as necessary for the production of the hypnotic trances experienced by those undergoing the therapeutic rituals; "Rhythmic drumming is of paramount importance in Coast Salish winter ceremonials, and the loud beating of rapid rhythms ... is a characteristic feature of spirit dance initiations" (p. 47).

Prince (1966) who has made similar observations in African and Haitian cultures states that, "It is possible that auditory driving, using the drum beat at 5-8 per second is a commonly used portal of entry into the dissociated state" (p. 134). Such ideas are often recounted in articles on trances and their reputed healing powers (see Laderman, 1983). Some have even speculated that trance-like states achieved through ceremonies involving compulsive repetition may result in the release of endorphins which may account for the eūphoric and healing effects of such rituals (Womack, 1980). Similar observations have been made in a recent article by Lex (1979) who goes further to examine the possibility of differential functioning of the cerebral hemispheres in the induction of trance states by sensory stimulation.

However, even in the course of demonstrating the existence of behavioural correlates of rhythmic stimulation by sound, whether these changes are directly related to physiological or neurological changes has yet to be determined. Even some specialists in the field reject the notion of the ability of rhythmic music to induce trances and cite evidence against psychophysiological theories of music and trance. In his criticism of Neher's theory of auditory driving, Rouget (1977) points out that the sounds employed by various possession cults differ markedly from those used in laboratory studies and states that "if the 'driving' effect [Neher] is referring to can be produced by beating a drum at a speed which can vary ... and

that speed can eventually be as slow as 4 beats/second ..., then the whole of sub-Saharan Africa should be in trance from the beginning to the end of the year" (p. 234, quoted in Erlmann, 1982). Although Rouget dismisses the theory that music has direct neurophysiological effects which aid in the production of trances he acknowledges the role of music in evoking emotional responses in conjunction with the production of trances (Rouget, 1980). Erlmann (1982), on the other hand, takes a more extreme view stating that "trance is not generated physiologically by music". Based on observations made by Rouget as well as his own field observations in which he notes that trance often occurs without any musical stimulation Erlmann offers an alternative theory based on culturally acquired abilities to self-induce trances through processes of identification and projection. In reviewing the neurophysiological theories of trance induction Goodman (1972) states that although it is unclear what role driving effects play in states of "dissociation" the effects of such stimulation are most likely culturally conditioned.

Obviously, it is necessary to avoid oversimplification of the relationship between music and its effects on the body in attempting to describe the neurophysiological mechanisms that may underly the production of trance-like states. It is also necessary here to avoid the kinds of errors made by investigators who linked the presence of alpha rhythms in the EEG with a particular state of consciousness associated with meditation or enlightenment. More recently it has been shown

that increased amount of alpha activity may only indicate decreased visual processing and that there is little experimental evidence to support the idea that rhythmic brain activity, such as alpha or theta "states", necessarily indicate any specific subjective state of mind, though the two often occur together (Beyerstein, 1984). It has yet to be determined whether physiological changes resulting from sensory stimulation are capable of producing behavioural changes or if they simply reflect internally mediated changes associated with a particular setting or situation in which the stimulation occurs.

Theta Rhythms and Auditory Driving

Neher (1961) has suggested that lower rates of repetition may be more effective for sound stimulation due to the presence of theta activity in the auditory cortex and with reference to the fact that the predominant rhythms in ceremonial drumming in various cultures fall within this range (Jones, 1954). Although theta activity is usually observed during the early stages of sleep, cortical theta rhythms have been observed in subjects who are alert with eyes open during advanced stages of Zen meditation (Kasamatsu & Hirai, 1966). Many theorists speculate that the relationship between theta activity and attentional states may be significant with respect to the rates of rhythmic stimulation used in ritualistic ceremonies based on studies such as Neher's (Lex, 1979; Chapple, 1970). However, in a recent review of the literature, Birbaumer (1977) states that there is

little experimental evidence to indicate that theta activity is associated with any particular mental state beyond drowsiness.

Cognitive Aspects of Repetitive Auditory Stimulation and Musical Rhythms

There has been a great deal of effort in attempting to define musical rhythm and in trying to understand the cognitive and perceptual processes involved in the experience of such rhythms. The study of musical rhythms is further complicated by the fact that complex sounds such as those found in most (but not all) forms of music exhibit figure-ground properties in which more than one temporal relationship (beat or rhythm) may be perceived from a single piece or phrase of music. It has been suggested that complex forms of music may in fact contain levels of rhythmic structure and that syncopated and other complex rhythms emerge from the interplay amongst these levels (Yeston, 1976; Handel & Lawson, 1983). Furthermore, what distinguishes musical rhythms from non-musical rhythms is difficult to define and often dependent upon culturally defined or learned concepts of music.

Gabrielsson (1982) notes that the study of musical rhythm is a complex area of research that must take into account the experiential, behavioural, and physiological components of the rhythm 'response'. The study of the perception of rhythmic structures in music from a cognitive perspective may eventually help us understand the esthetic and qualitative value of such organizing principles in music.

The use of simple rhythmic structure is found in music of all cultures and one may wonder as to how this has evolved. This raises the question of whether rhythm is strictly a cultural phenomena or whether there is some innate tendency for the body to respond in a certain way to rhythmic or repetitive sounds. Certainly there are differences in terms of the kinds of rhythms that are used in the music of a certain culture or society and the relative importance of rhythm to that culture and these differences may be interesting in themselves. For example, one investigator has found a strong relationship between infant carrying practices and the percentage of regular rhythms in music among different cultures indicating the possible effects of early experience in cross-cultural variations in rhythm (Ayres, 1973). In order to answer questions regarding the biological foundations of rhythm and rhythm responses, it may be necessary to consider whether responses to auditory rhythms can be studied apart from their musical context and strictly in relation to their physical effects upon the body.

Biological Rhythms and Motor Theories of Rhythm

Many early theories of rhythm attempted to relate musical rhythm to some basic physiological process, such as the beating of the heart, breathing patterns, or some basic rate of activity in the nervous system. However, such explanations were unable to account for the complexity of musical rhythms and their

perception and were for the most part abandoned due to lack of experimental evidence supporting them (Radocy and Boyle, 1979).

Later theories began to consider rhythm as a learned response and placed more emphasis on motor aspects of the rhythm response (Lundin, 1967). Historically, rhythmic body movement has been associated with the perception of acoustic rhythms. Motor theories of rhythm hold that the voluntary action of the muscles and the subsequent kinesthetic feedback play an important role in the perception and experience of a musical rhythm. This close interrelationship between musical rhythm and movement is most recently expressed by Clynes and Walker (1982):

The power of musical rhythm to generate moods, shades of feeling, attitudes, and various types of mental and physical energies - in short, the psychic function of rhythm - is seen to relate to the way in which sound patterns are transduced by the nervous system to modulate the neural driving patterns that, in imagination, or actually as in dance, control the form of movement. (p. 172)

Motor theories raise some interesting questions regarding the concept of musical rhythm. Is rhythm a specific temporal structure of sound that results in a rhythm response, the learned motor responses to what are perceived to be rhythms, or some combination of the two? Fraisse (1982) notes that one of the most interesting aspects of rhythm is the ability to "synchronize" body movements with the sound pulses. This differs from most examples of stimulus-response type behaviour in terms of one's ability to anticipate the stimulus -- even in the case of complex rhythms. In this sense what is important is not the regularity of the stimulus but the ability to anticipate it.

Indeed, moving 'in time' to a beat or rhythm is often seen as an important component of rhythmic perception and may possibly even determine the range of frequencies or rates of repetition that are perceived as musical rhythms. Auditory pulses that are separated by more than about 1 1/2 seconds are no longer perceived as being linked together in time. Faster rates of presentation up to 8 to 10 pulses per second can be identified as separate elements after which the repeated sound pulses will begin to be perceived as a steady tone (Fraisse, 1982), though the upper limit for motor synchronization with such pulses is about 6 or 7 per second (Bartlett & Bartlett, 1959). Interestingly, when presented with very fast repetitive sounds individuals tend to select out and identify slower patterns (eg., subharmonics of the stimulus rate) as the beat or tempo that is present. It also appears that individuals are capable of using 'grouping' strategies in the case of complex, or conflicting rhythms in order to identify a simpler underlying beat or temporal structure. The exact nature of such strategies and why there is a tendency to use them is not completely understood as yet, nevertheless, motor synchronization most likely plays an important role (Handel & Lawson, 1983).

Neural Representations of Musical Rhythms

If presented with a sound pattern (even a fairly complex one) most individuals will be able to reproduce the pattern, by

tapping their finger, for example, with a fair degree of accuracy. Therefore temporal patterns must be stored in memory somehow allowing the pattern to be reproduced either mentally or by physical movement or to be recognized later in time. No doubt musicians possess many such rhythm memories or 'templates' which allow them to recreate complex sound patterns or to maintain a steady meter during musical performance.

Clynes (1982) refers this aspect of musical memory as "time-form printing" in which a certain temporal pattern may be stored in memory. Once formed this 'pattern' may be reiterated automatically until further modification. It would seem, given such memory processes for rhythms, that the creation or recreation of a temporal pattern involves the initiation of motor programs that are initially capable of ongoing modification and correction (possibly involving 'template matching' or some other comparison process) and eventually able to function with a certain degree of automaticity. Such automaticity allows a person such as a trained musician to produce many complicated sound sequences or melodies without having to concentrate on the underlying time structure. One must distinguish at this point between the production of musical rhythms and perception of such rhythms -- these two processes may engage different brain structures. How temporal patterns are recognized by sensory systems and how such patterns are recreated motorically presents an interesting area of research into the interactive nature of brain systems.

It may be appropriate here to address again the question of what defines musical rhythm. As is noted by Clynes (1982) there is in musical rhythm a "hierarchical organization of the experience of frequency". Thus, our experience of music can be thought of as perceptual organization of a broad frequency range of sound waves. Sounds within the frequency range of about 20 Hz to 20 kHz are perceived as tones -- frequencies lower than this may be perceived as "beats" or rhythms. (Of course these slower frequencies must be composed of the amplitude modulation of one or more frequencies within the auditory range since only the higher frequencies can be transduced by the basilar membrane and thus be perceived as "sound" -- low frequency sounds by themselves may be sensed as vibrations in the somatosensory modality).

Music⁵, therefore, consists of the cognitive organization or grouping of frequency or iterations in time. In the same way tones (high frequencies) are grouped according to certain cognitive principles⁶ to form pitch and melody, lower rates of repetition are grouped together forming what is commonly referred to as musical rhythm. The neural encoding mechanisms for different frequency ranges may differ (eg., place theory versus periodicity theory) however it may be assumed that neural systems so well equipped at encoding temporal patterns as slow as 20 cycles per second would not have difficulty in processing slightly slower temporal patterns that arrive through the same sensory system. Again the complexity of such sensory

processing lies partly within the functioning of the auditory system itself, for example, the nature of encoding of sound intensity, frequency (waveform), and phase in the peripheral auditory system which would account for the complex, nonlinear relationships between intensity, pitch, and perceived loudness.

Hemispheric Specialization and the Neural Basis of Rhythm

Recently there has been a great amount of interest in the role of cerebral dominance in the perception of musical stimuli particularly in connection with speech processing. It has been shown, using dichotic listening tasks, that the nondominant cerebral hemisphere (the right hemisphere in most right-handed individuals) is better at processing nonverbal sounds, such as music, whereas, the dominant hemisphere is more capable at processing speech. It has been proposed by some that this reflects hemispheric specialization for analytic processing (dominant hemisphere) in speech versus holistic processing (nondominant hemisphere) for musical stimuli. Cerebral dominance for the perception of rhythm is not as clearly defined. Temporal qualities of speech and music are considered to involve 'analytic' modes of processing due to their sequential nature, and complex temporal sequences are therefore expected to be processed better by the dominant or speech hemisphere. However, rhythmic stimuli have been reported to be processed preferentially by both the dominant (Robinson & Solomon, 1974; Borchgrevink, 1982) and nondominant hemispheres (Roland,

Skinhoj, & Lassen, 1981).

There remains some controversy over the mechanisms involved in observed lateral differences in auditory processing and it appears that hemispheric specialization for the perception of rhythm may depend on factors such as the complexity of the rhythm, cognitive strategies used in processing the sounds, and musical experience of the listener. Pribram (1982) suggests that less complex temporal sequences may be processed at a deeper level than the cerebral cortex since anesthetization of either cerebral hemisphere (the Wada test) does not appear to interfere with the subjects ability to follow a simple rhythm although lateral differences have been found with this technique using more complex temporal patterns.

Further, level of musical sophistication of the subject may also affect the type of cognitive strategy used in processing musical sounds and thus the hemisphere activated during such processing -- musically naive subjects may use subjective, nonanalytic strategies and show right hemisphere preference, while musically sophisticated subjects may be using analytic strategies and show left hemisphere preference (Bever & Chiarello, 1974; Mazziotta, Phelps, Carson, & Kuhl, 1982). Thus, although there appears to be some evidence for hemispheric specialization in the perception of musical rhythms it is necessary to take into account the nature of the cognitive processes involved as a function of the complexity of the temporal patterns in question as well as the musical experience

of the listener.

Approaches to the Study of the Psychophysiology of Rhythm

In order to study the physiological foundations of rhythmic perception and performance it is necessary to consider all aspects of rhythmic responses of the body and their measurement. This includes the relationships between sensory processing of various complex sound patterns, the perception of these patterns as "rhythms", and the subsequent responses to these perceptions -- whether they be overt motor responses or simply one's awareness of the presence of something that is perceived as being something more than just a repetitive or monotonous sound.

Figure 1 illustrates a model showing the various pathways involved in the perception and production of auditory rhythms. As is noted by Gabrielsson (1982) feedback is an important component in the rhythm response particularly for rhythmic performance.

This model indicates that output may be compared to input either through an external loop of sound production or by an inner pathway of feedback from receptors in the muscles and joints (dotted lines). The inner feedback loop is of particular interest to those proposing motor theories of rhythm. As well, production of sound patterns that are too rapid for ongoing

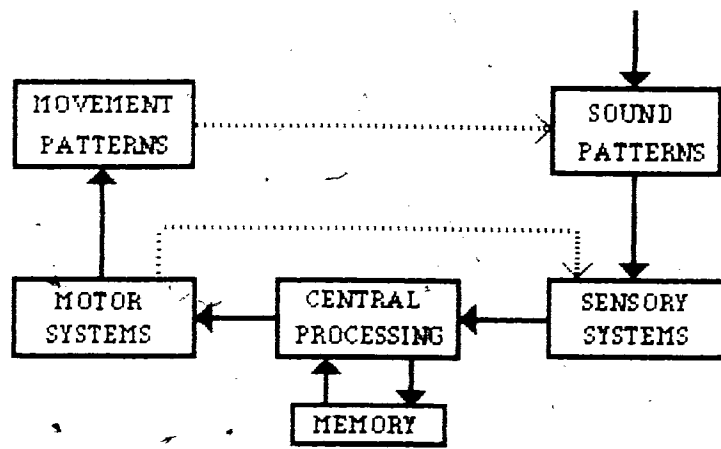

Figure 1. A general model showing pathways involved in the perception and performance of rhythmic sound patterns. External feedback produced during musical performance (upper dotted line) is important in learning and creating musical rhythms. Kinesthetic and tactile information (lower dotted line) may aid in the perception of such rhythms.

correction from feedback information must be produced using preprogrammed or 'feedforward' mechanisms.

Activity in these pathways may be observed at various levels. Sound patterns may be analyzed and accurately described in terms of frequency, duration, and intensity. The questions of how information contained within the sound pattern is transformed into a neural code that allows the pattern to be stored and reproduced later still holds a major challenge to those studying sensory physiology.

Presently, brain responses to various sounds may be studied using EEG recording techniques in the following ways.

(i) during sensory input (evoked or "event-related potentials" observed during a discrete sensory event)

(ii) during memory retrieval or template comparison processes (later components of the event-related potential)

(iii) during motor output (readiness potentials occurring during preparation for movement or motor potentials recorded over areas of the brain controlling specific parts of the body just prior to movement of those parts).

II. Present Study

This thesis represents an attempt to study psychophysiological responses to naturally occurring rhythmic sounds, particularly drumming sounds, within a laboratory setting. Since past research has concentrated on one physiological measurement at a time it is difficult to compare findings between studies and little attempt has been made to integrate the various approaches to the study of physical responses of the body to rhythmic sound. Furthermore, much of the past research has done little to designate the appropriate parameters of measurement for the study of responses to naturally occurring sounds. Past studies have had their emphasis either on the psychophysics of auditory perception or have been more concerned with the behavioural phenomena associated with such forms of physiological stimulation as it occurs in a natural setting; the former being conducted under such necessarily rigid laboratory conditions as to be unable to study the responses in question in a 'naturalistic' environment and the latter often being conducted in a "too uncontrolled" manner to be able to withstand criticism of the methodology involved. Consequently, it is difficult to integrate these two sources of information in order to clearly understand the psychobiological bases of responses to rhythmic sounds, particularly those which are implicated in changes in states of consciousness, bizarre

behaviour, ritualistic usages and so on. This thesis is therefore presented as as a preliminary study to determine if responses to naturally occurring sounds can be studied within a relatively controlled laboratory setting and if so, whether various psychophysiological indices can be considered concomitantly in order to provide a better description of the physiological processes occurring during such phenomena. The purpose of the experiment was basically threefold.

(1) to replicate to some degree Neher's (1961) study in order to observe whether a repetitive, naturalistic stimulus (ie., drumming) is capable of producing recruitment of EEG rhythms, and if so, to determine if the response is dependent on certain rates of stimulation.

(2) to determine to what extent peripheral responses are involved in EEG effects observed during this kind of stimulation by monitoring surface EMG (specifically motor responses that may be produced by "natural" rhythms), heart rate, and respiration.

(3) to detect possible relationships between rates of natural (musical) rhythms, observed motor responses, EEG changes (such as recruitment effects), and other behavioural changes (eg., changes in levels of general arousal).

B. Method

Subjects

y Four female and four male adults recruited from the Vancouver area and Simon Fraser University population served as subjects in this study.

Apparatus and Recording Procedures

Recordings were made using Beckman Ag-AgCl electrodes filled with Beckman electrode paste and affixed with collodian and adhesive collars (electrode impedences were below 5 kohms for all EEG leads).

All signals were sampled at a rate of 200 samples/sec and stored on magnetic tape for further analysis off-line. Digitized signals could be monitored on a control room CRT display throughout the recording procedure. Data collection and analysis was carried out with the aid of a Data General Nova 3D computer system equipped with an RDOS operating system (H. Gabert, P. Eng. is responsible for system software and hardware.)

Monopolar EEG was recorded from Fpz, C3, C4, T3, T4, and Oz placements referenced to linked mastoids (A1+A2) using the 10-20 system and amplified through A.C. amplifiers with bandpass filtering from 1 - 50 Hz. (with a rolloff of 40 dB/decade). Heart rate was recorded from a sternum electrode referenced to the lower back and fed to a cardiometer which provided a

continuous digital record of R-R intervals in milliseconds.

Respiration was monitored by means of a thermistor transducer placed below the subjects nostrils.

Eye movements were monitored via bipolar recordings from right supraorbital and zygomatic electrode placements.

In some subjects surface EMG was recorded using Beckman Ag-AgCl electrodes placed over the forearm muscles (ulnar region) in order to monitor rhythmic hand movements on either side of the body (eg., finger tapping produced synchronous spikes in the EMG signal).

The audio signal was monitored by a microphone placed directly over the subjects head. This signal was rectified and filtered producing an audio envelope signal (Appendix A) that provided a smooth continuous record of the amplitude modulated sound source (eg., a drum beating at 4 beats per second would produce a smoothly oscillating signal of the same fundamental frequency).

Subjects were fitted with the above devices and seated in a large comfortable arm chair placed in an electrically shielded, sound attenuated room. Acoustic stimuli were presented through two large stereo speakers placed in front and to either side of the subjects (Figure 2).

FIGURE 2

DIAGRAM OF LABORATORY LAYOUT
SHOWING POSITION OF SUBJECT
AND APPARATUS DURING RECORDING
PROCEDURE.

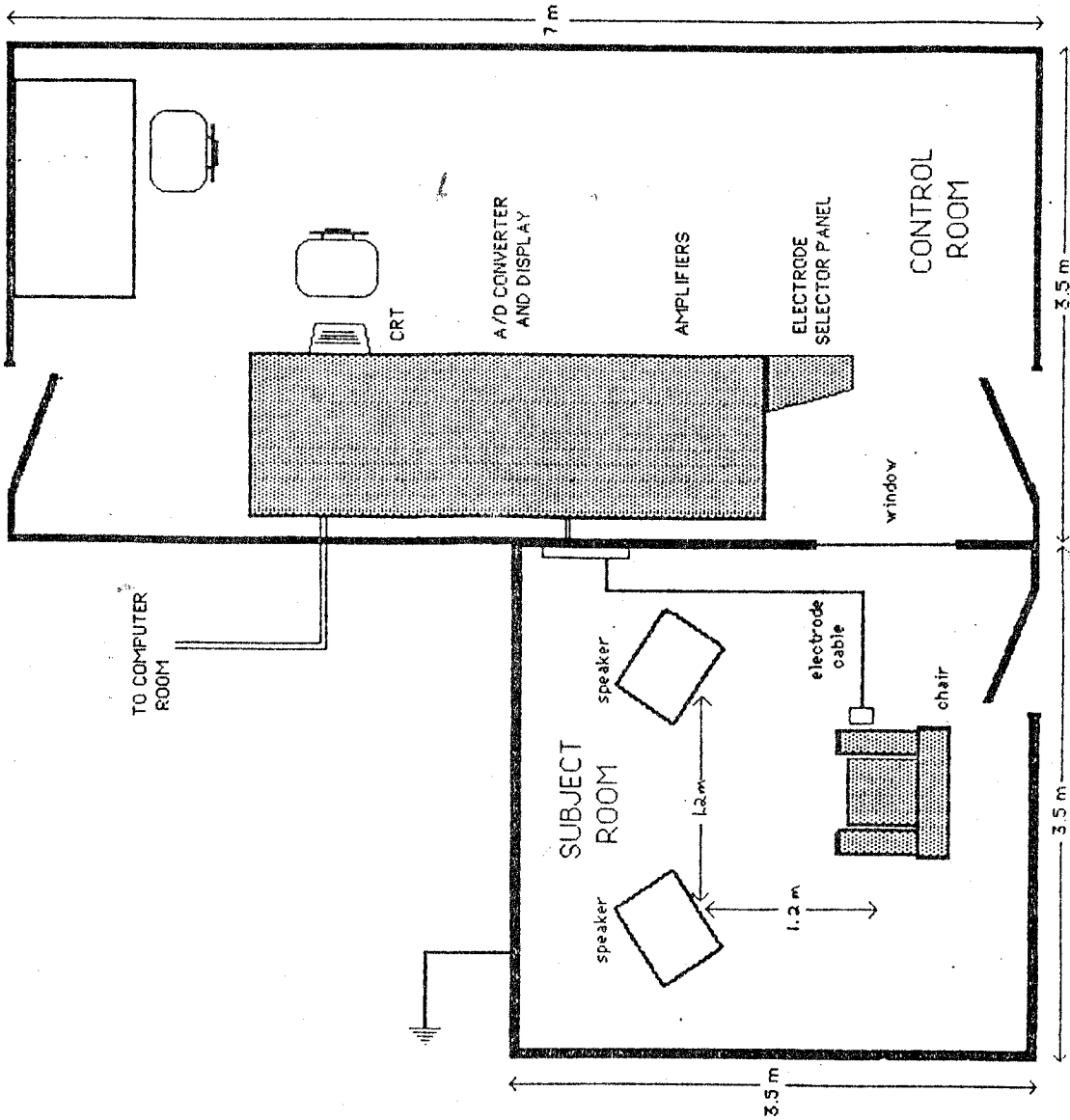

Stimulus Materials

The following sounds were presented to the subjects by means of a Sony reel-to-reel tape recorder at a sound intensity of approximately 90 dB. (note: Conga drum tapes were presented to only two of the subjects - N.H. and C.B.).

(i) Conga drum. A tape of repetitive beats on a conga drum (approximately 5 and 10 beats per second).

(ii) Repetitive drum beats. These were produced by means of a tape loop of steady beats on a tom tom drum providing an even repetitive drumming sound at rates of 3.4, 4.5, 6.8, and 9.0 beats per second. (The two highest rates were produced by playing the tape loops at double speed since it was not possible to beat the drum at this speed, thus the pitch of the drum for these rates were shifted to higher (2x) values accordingly. Frequencies were chosen so as not to be harmonics of each other.)

(iii) Symphony. (J. S. Bach, "The Art of the Fugue Groups (No. 2)").

(iv) Rhythmic music. (J. Hassel, "Chor Moire" (from Dream Theory in Malay) -an instrumental piece consisting of a mixture of uneven rhythms together with woodwind instruments.

In addition photic flashes were presented to two of the subjects at rates similar to the auditory stimulation (4.0, 5.0, 7.6 and 10.0 flashes/sec.). Flashes were presented using a Grass

PS22 photostimulator at maximum intensity placed behind an opaque screen which produced a brightness level that subjects could fixate on without discomfort (a flash rate of 10/sec. produced an luminance level of approximately 18 fL. measured with a Spectra Pritchard photometer).

Testing Procedures

Subjects were given the following treatments.

Two subjects (C.B. and N.H.) performed instructed tapping movements of both hands and feet with and without accompanying drum beats. These subjects also listened to conga drum beats at 5 and 10 beats per second with eyes open and eyes closed.

The remaining six subjects listened, with eyes open, to symphony, rhythmic music, and four rates of drum beats for durations of 3 minutes each.

Two of the above subjects (G.S and D.W.) also received photic stimulation, with eyes open, at rates of 4.0, 5.0, 7.6, and 10.0 flashes per second.

Data Analysis

The following analyses were performed on the raw data.

The EEG records were subjected to Fourier analysis (FFT) in order to determine the presence of predominant frequencies within the EEG signal. 3.84 second epochs (256 points) were

selected from the raw data after smoothing (producing an effective sampling rate of 66.6 samples/sec.) from corresponding time periods across conditions and across subjects. Histograms were created (Figures 3 - 1 through 3 - 14) by calculating the average power over 5 epochs of data (a total of 19.2 seconds of data) per condition. This provided a relative measure of the predominance of the frequency components in the EEG signal corresponding to each of the stimulus rates used with respect to each other. Thus each value corresponds to the relative predominance of a particular frequency component over the entire stimulus condition. This analysis was applied to five EEG channels -- C3, C4, T3, T4, and Oz. (The Fpz lead was excluded because of excessive eye movement artifacts in that channel. Oz is absent in one subject).

Frequency spectra were also plotted for each condition and electrode position. Due to limitations of the FFT program capabilities it was not possible to plot the spectra corresponding to the histogram data. Each spectrum corresponds to a single 3.84 second epoch selected from the middle of each condition period. (256 points provided an optimal resolution for plots of frequency spectra).

Respiration data were analyzed using a peak detection algorithm which was used to compute the average respiration interval (ie., average time between successive positive or negative peaks in the respiration signal) for successive 6 second epochs. This provided a continuous plot of average

respiration rate for the duration of the recording session.

Heart rate was analyzed by plotting the R - R intervals (in milliseconds) over the duration of the testing session. The signal was smoothed using a software smoothing filter of 64 points (0.32 seconds) prior to plotting.

EMG data were analyzed by plotting the rectified EMG signals with an expanded amplitude scale in order to detect any changes in resting level activity in the contralateral limb muscles during tapping movements.

C. Results

EEG Data

Auditory Stimulation



Frequency analysis of EEG recordings during repetitive auditory stimulation (drumming at 3.4, 4.5, 6.8 and 9.0 beats/sec) revealed no relative increase in magnitude of frequency components in the EEG signal corresponding to the stimulus frequency, ie., no indication of auditory driving was present in any subject across all electrode positions and stimulus rates (Figures 3-1 to 3-12). Frequency components were compared against each other in order to provide a relative measure⁷ of their overall predominance in the EEG signal for each electrode placement. Thus, each magnitude value represents the predominance of the specified frequency component in the EEG, relative to the other frequency components for which magnitudes were calculated, in selected epochs occurring throughout the period of stimulation. Overall power of the entire spectrum and power within frequency bands (alpha, theta) were not calculated (see ref. note 7). (Earlier analyses using FFT analysis of a single 20 second epoch of data produced similar results.)

Examination of the plotted EEG frequency spectra (single 3.8 second epochs of data) across conditions and electrodes (Figures 4-1 to 4-6) shows no indication of auditory driving.

(peaks at the stimulus frequencies) but does show marked differences across conditions and across subjects in terms of the overall distribution of power in the total spectrum.

Frequency analysis performed on two subjects who received auditory stimulation at 5.0 and 10.0 beats/second (tape of conga drum) also failed to show any evidence of auditory driving effects (data not shown).

Photic Stimulation

Analysis of EEG recordings during photic stimulation at 4.0, 5.0, 8.0 and 10.0 flashes/sec. indicated the presence of photic driving effects in all electrode placements and for all four rates of stimulation, although responses appear most pronounced for stimulation at 10.0 Hz and for EEG recorded from Oz electrode position (Figures 3-13 and 3-14).

Inspection of the spectra for the photic stimulation conditions indicates the presence of driving responses as peaks at both the stimulus frequency and first harmonic of the stimulus frequency (Figures 4-7 and 4-8). Again, this effect appears strongest for stimulation at 10.0 Hz., particularly in one subject (Figure 4-7).

Inspection of the raw EEG records for both auditory and photic stimulation indicates similar findings for the entire period of stimulation (up to 3 minutes in duration for auditory stimuli) -- the presence of clear driving can be seen in the

Figure 3 - 1 Average magnitude of EEG frequency components for each electrode placement (condition as indicated). (Subject G. S.)

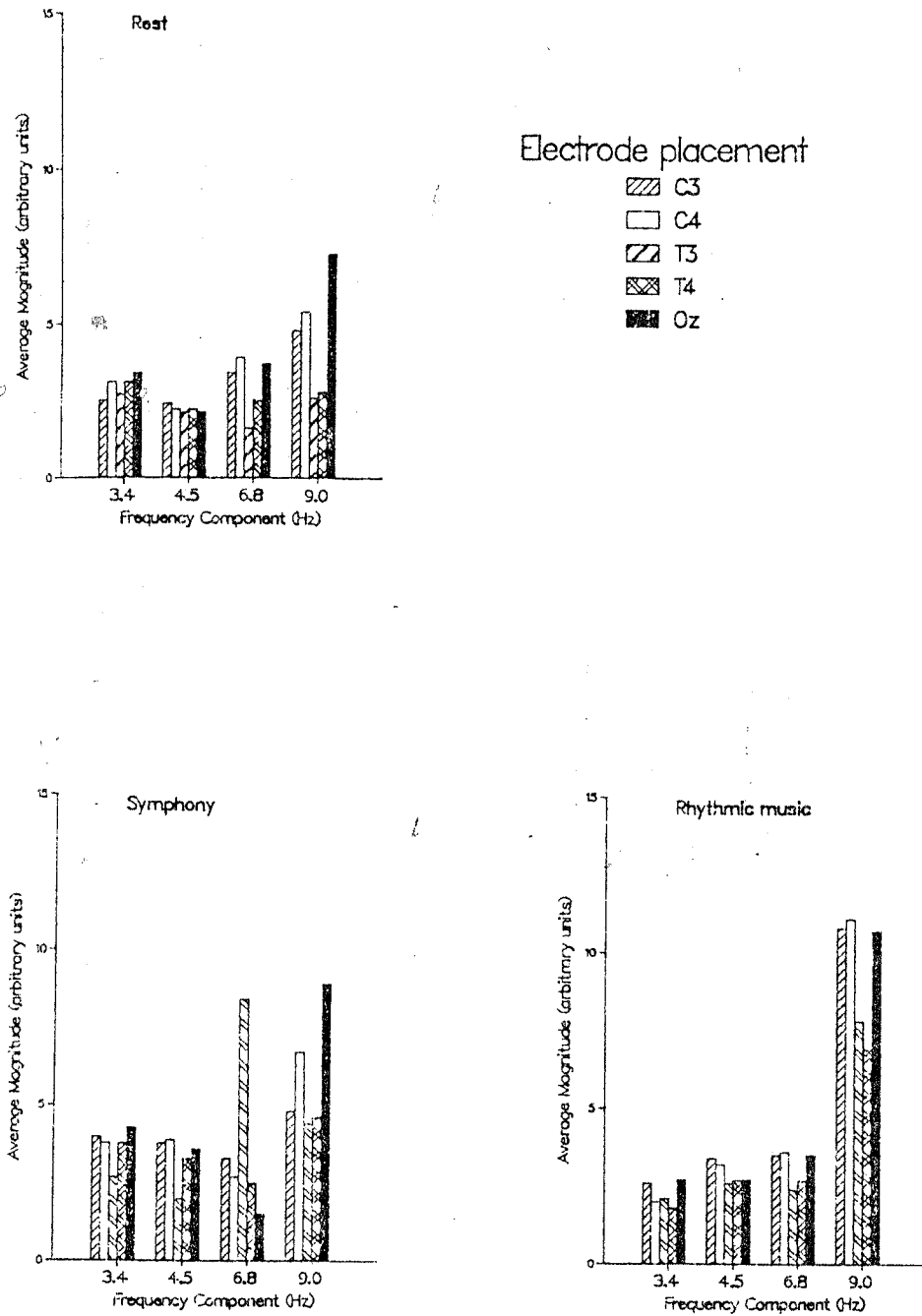

Figure 3 - 2. Average magnitude of EEG frequency components for each electrode placement (condition as indicated).
(Subject G. S.)

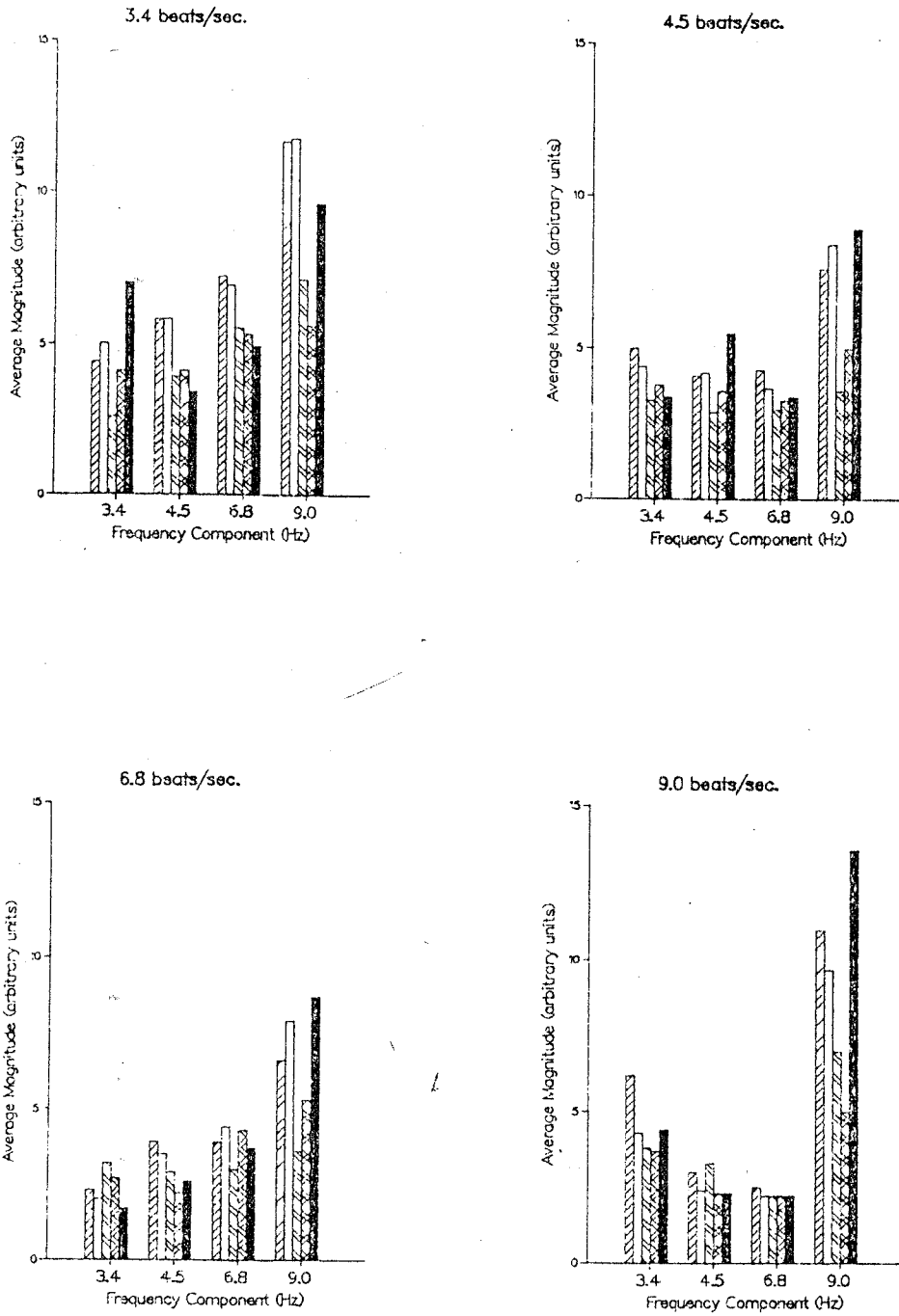

Figure 3 - 3. Average magnitude of EEG frequency components for each electrode placement (condition as indicated). (Subject D. W.)

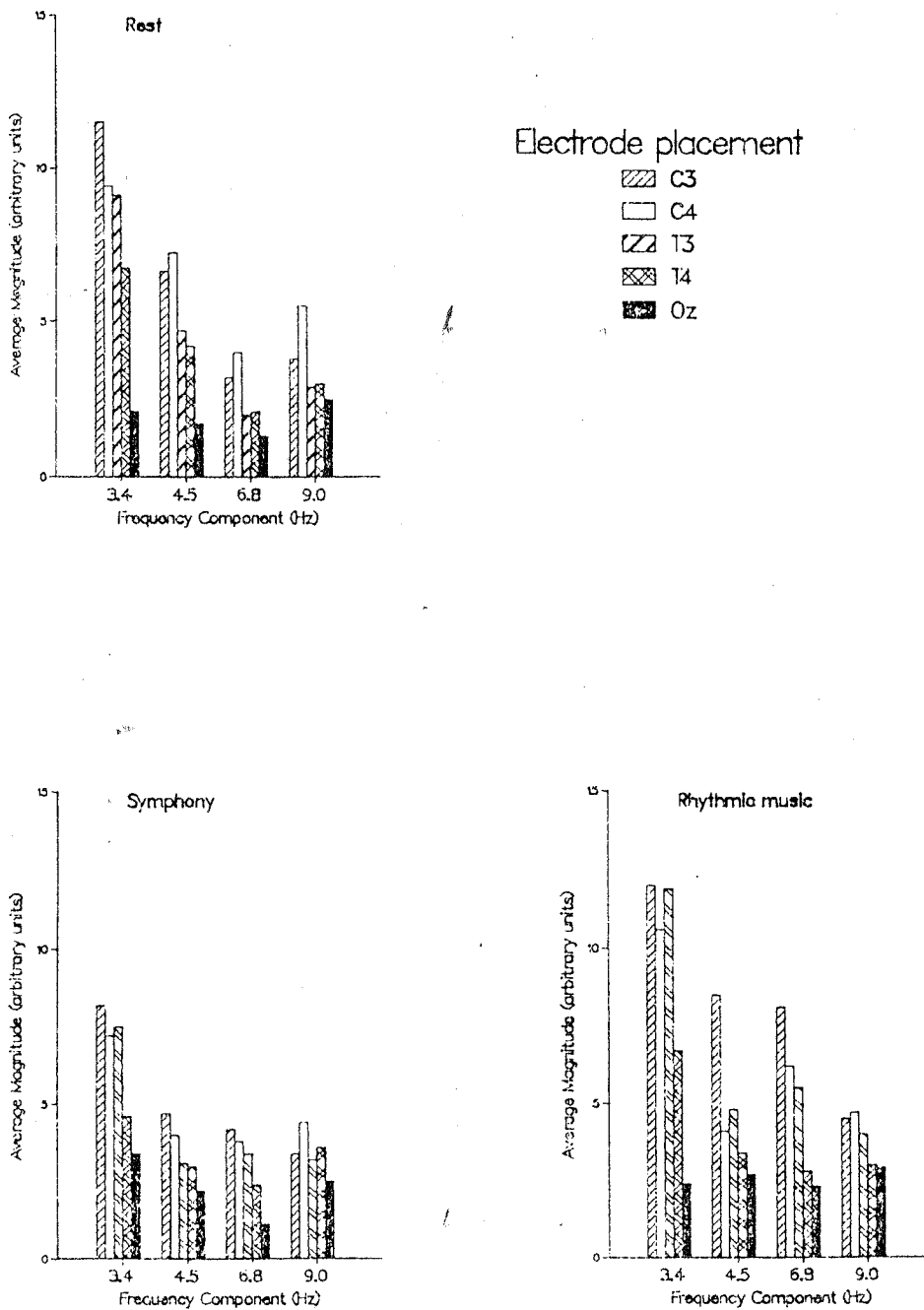

Figure 3 - 4. Average magnitude of EEG frequency components for each electrode placement (condition as indicated). (Subject D. W.)

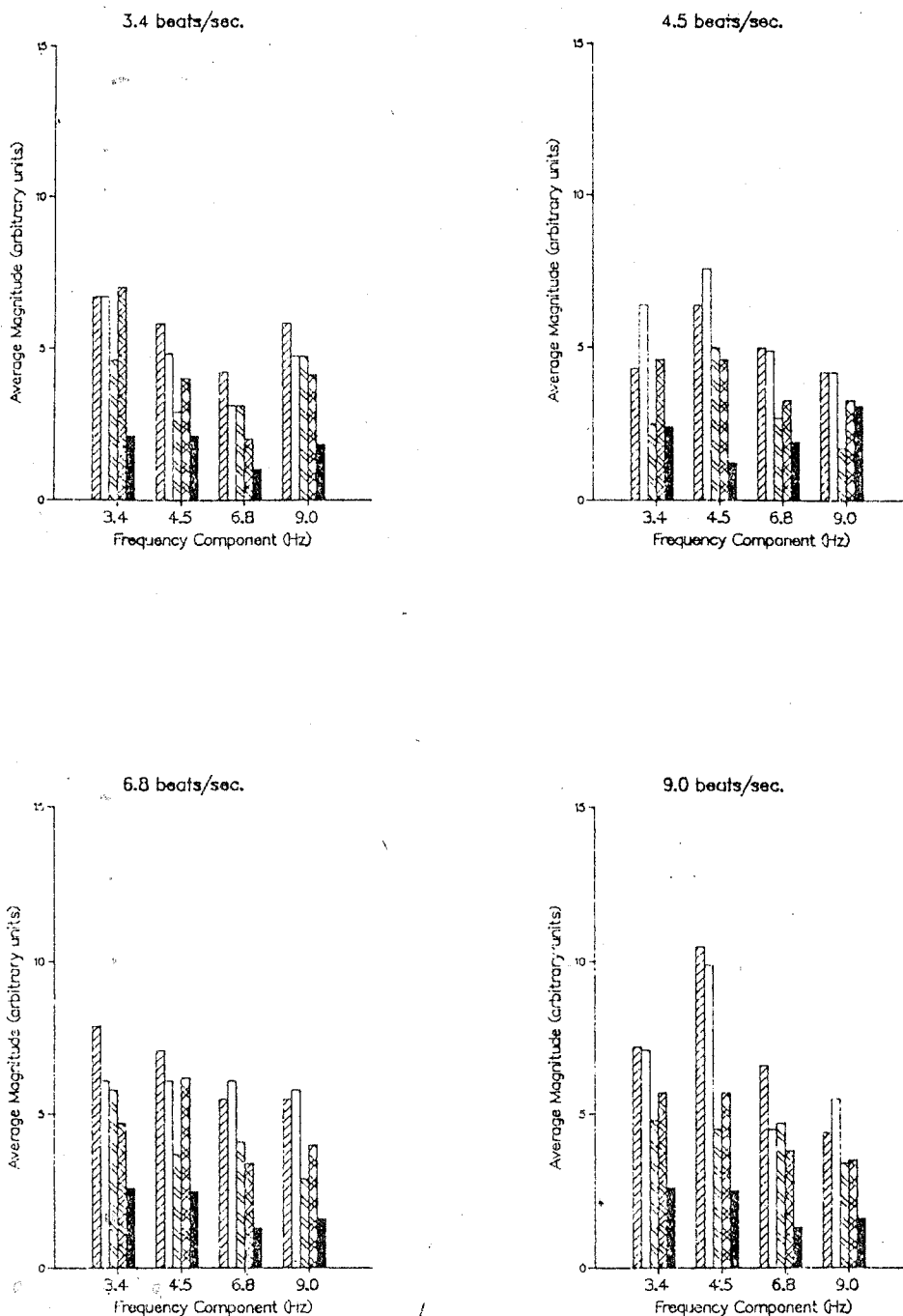

Figure 3 - 5. Average magnitude of EEG frequency components for each electrode placement (condition as indicated). (Subject P. R.)

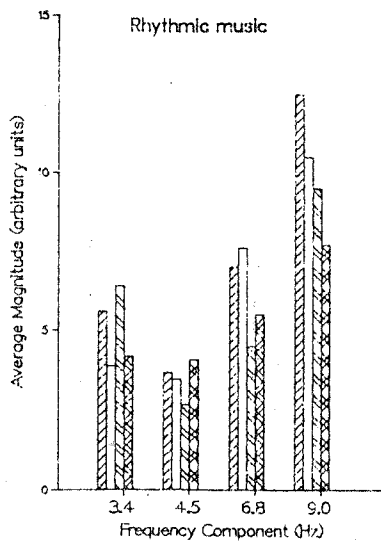
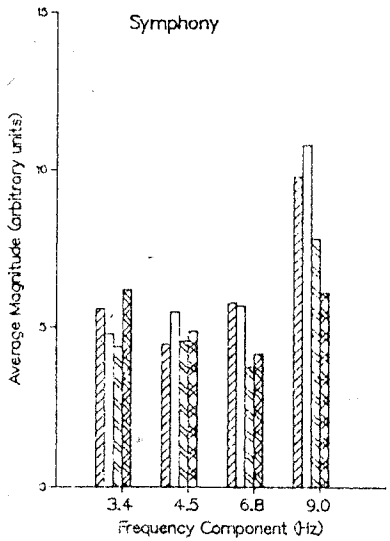
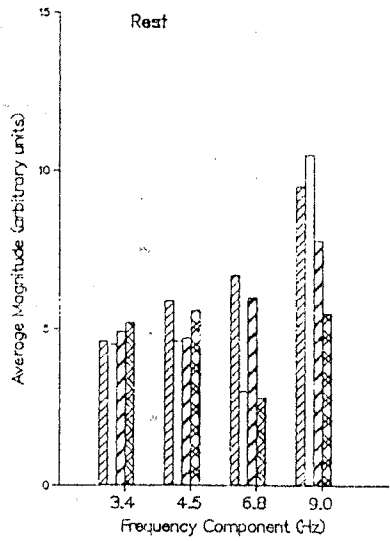

Figure 3 — 6. Average magnitude of EEG frequency components for each electrode placement (condition as indicated). (Subject P. R.)

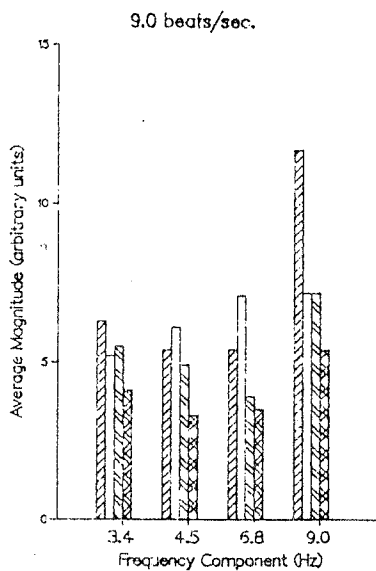
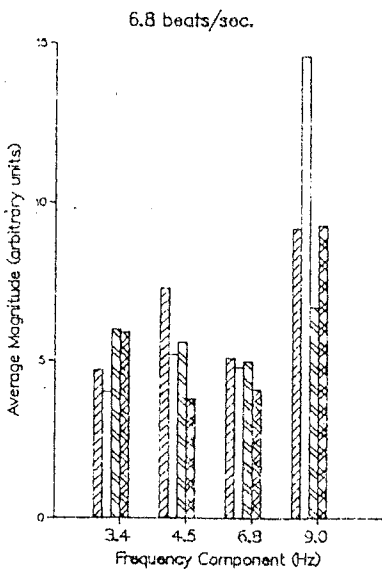
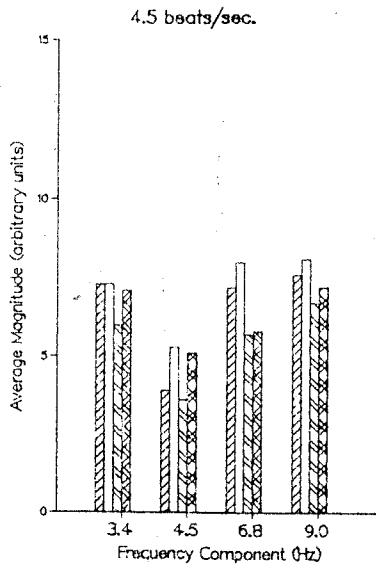
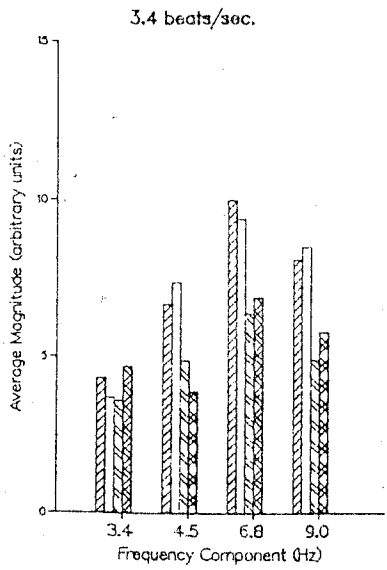

Figure 3 - 7. Average magnitude of EEG frequency components for each electrode placement (condition as indicated). (Subject K. W.)

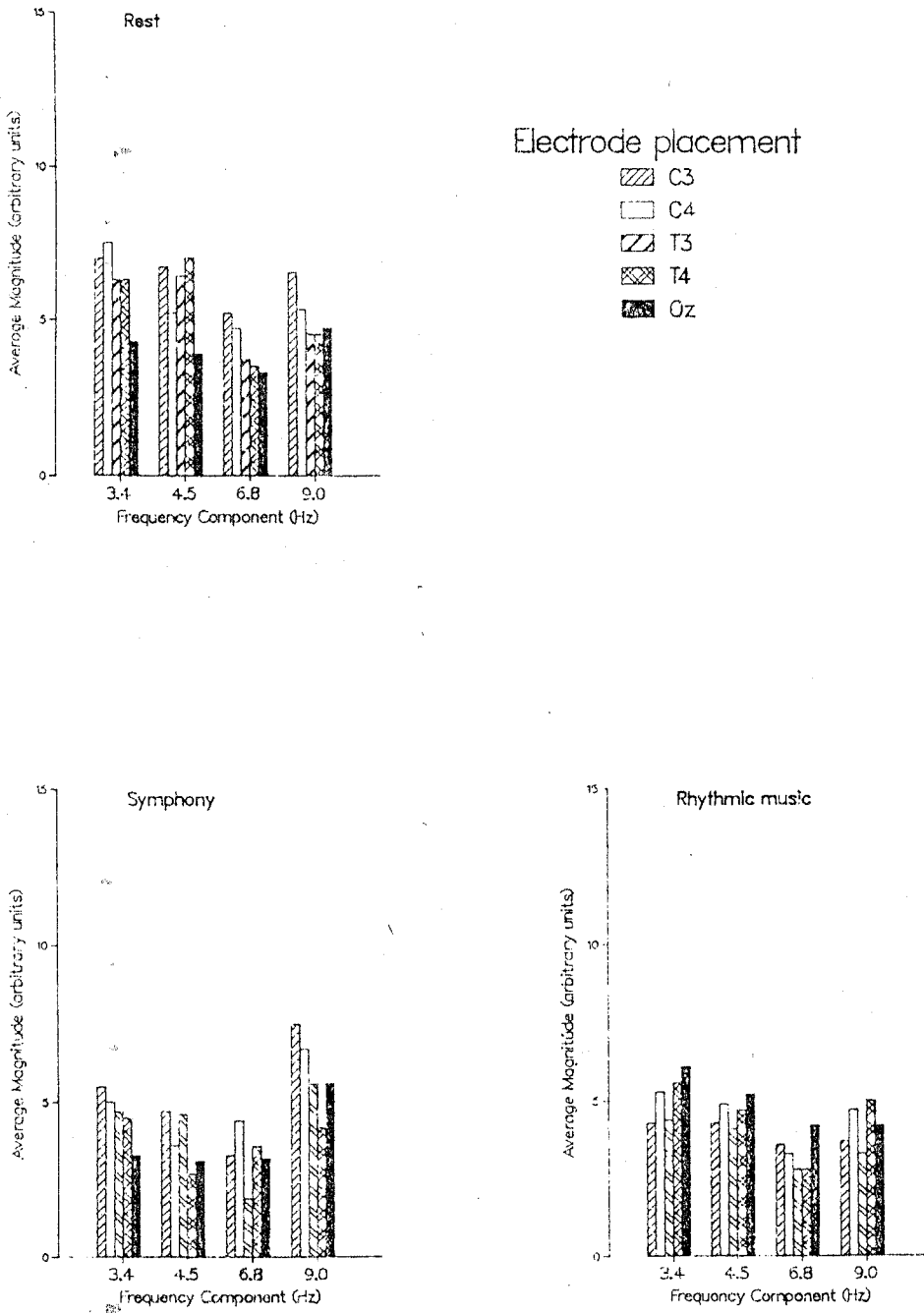

Figure 3 - 8. Average magnitude of EEG frequency components for each electrode placement (condition as indicated). (Subject K. W.)

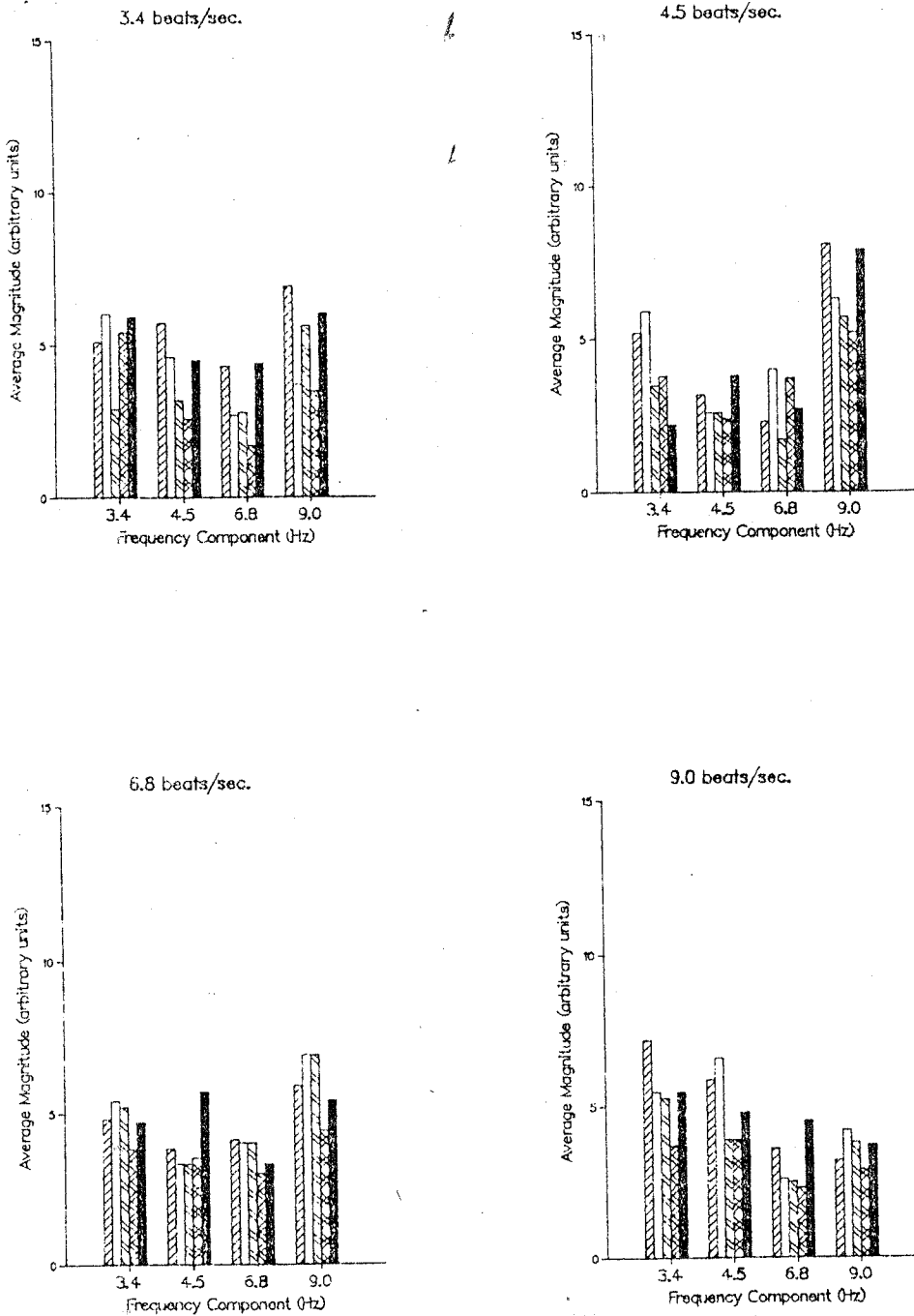

Figure 3 - 9. Average magnitude of EEG frequency components for each electrode placement (condition as indicated). (Subject L.R.)

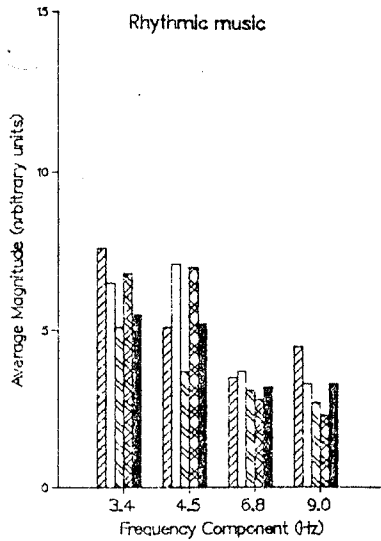
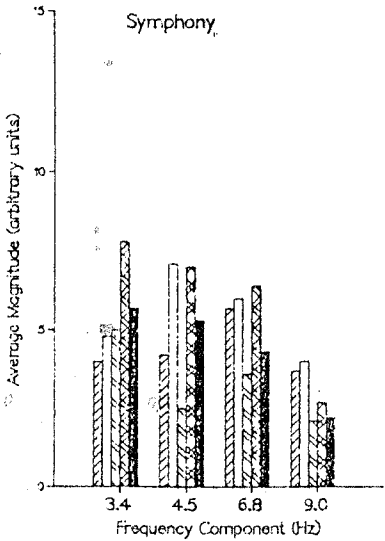
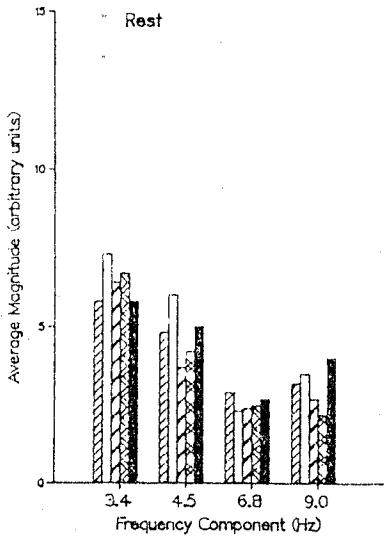

Figure 3 - 10. Average magnitude of EEG frequency components for each electrode placement (condition as indicated). (Subject L.R.)

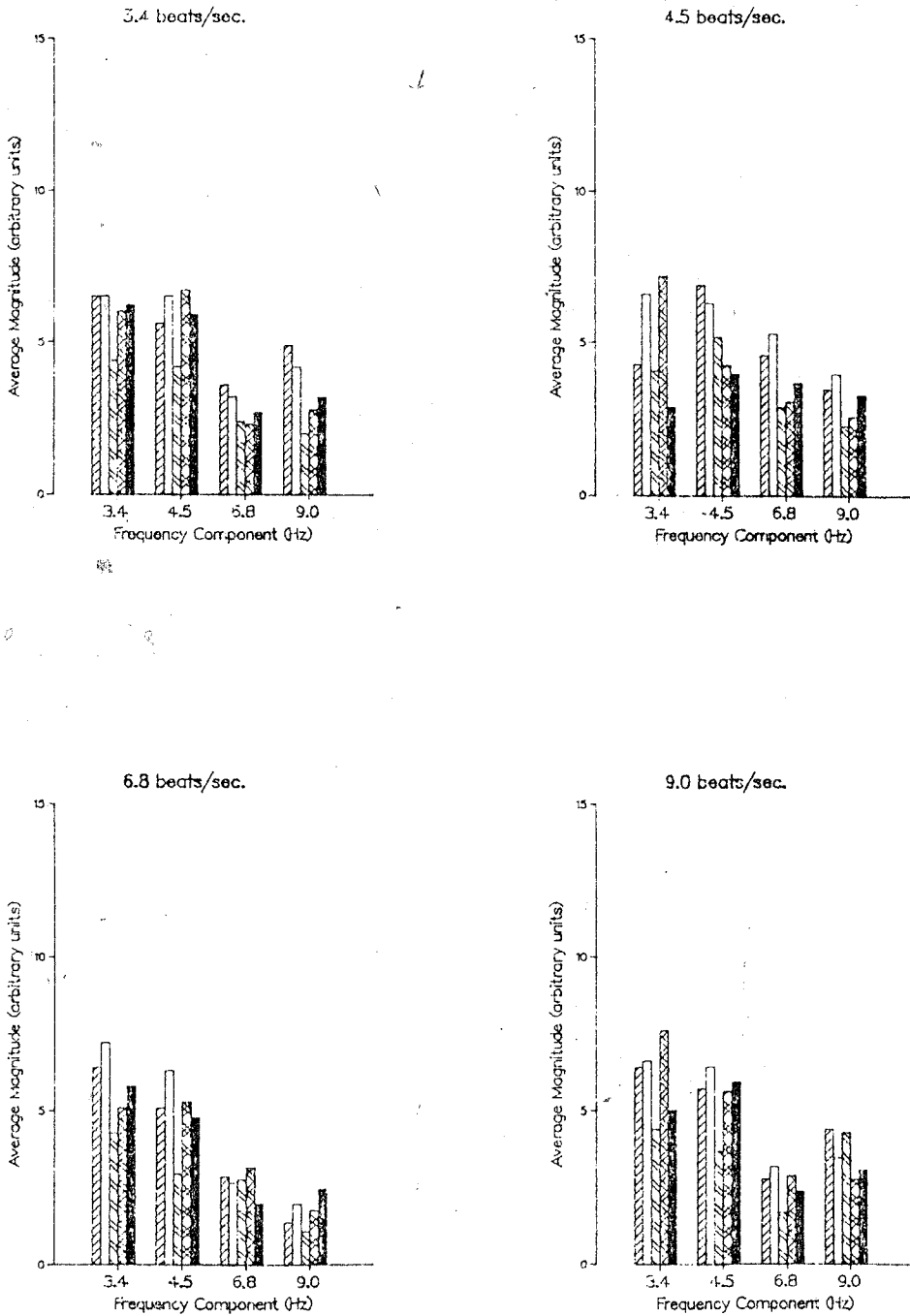

Figure 3 - 11. Average magnitude of EEG frequency components for each electrode placement (condition as indicated). (Subject M. G.)

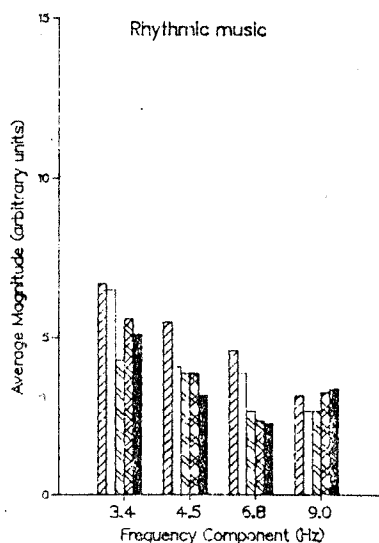
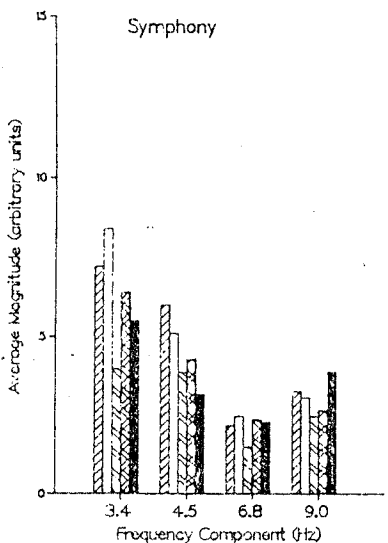
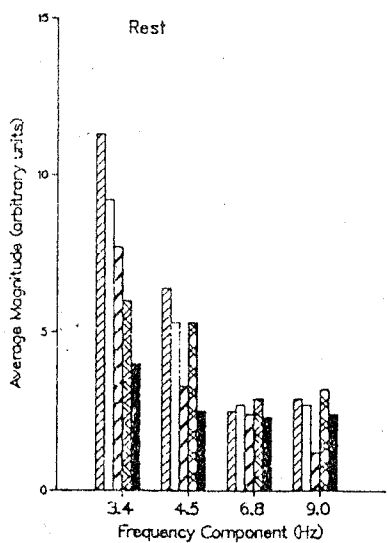

Figure 3 - 12. Average magnitude of EEG frequency components for each electrode placement (condition as indicated). (Subject M. G)

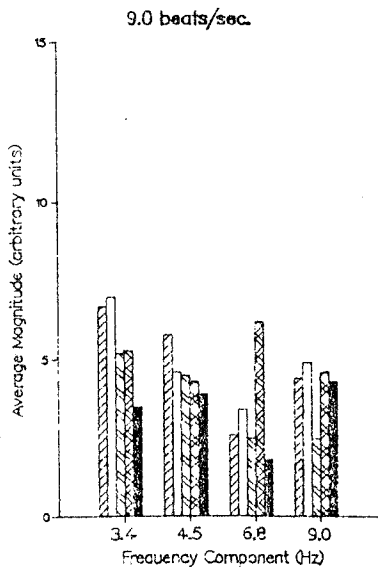
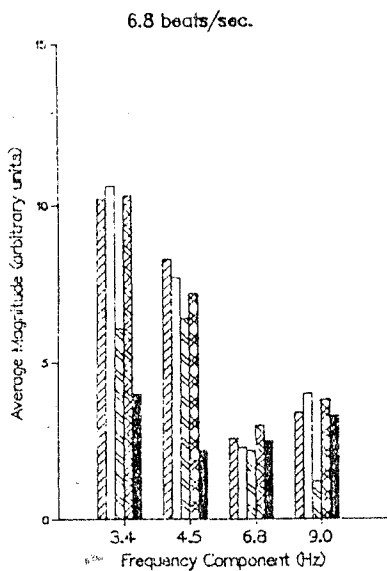
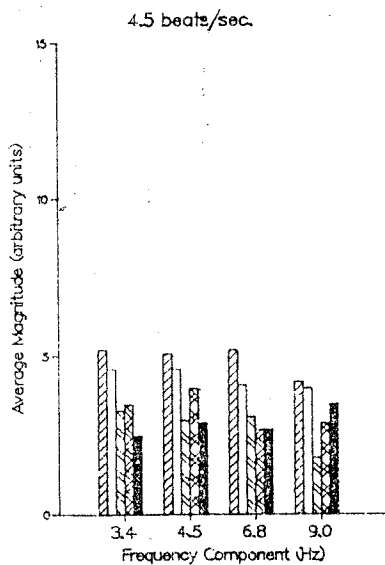
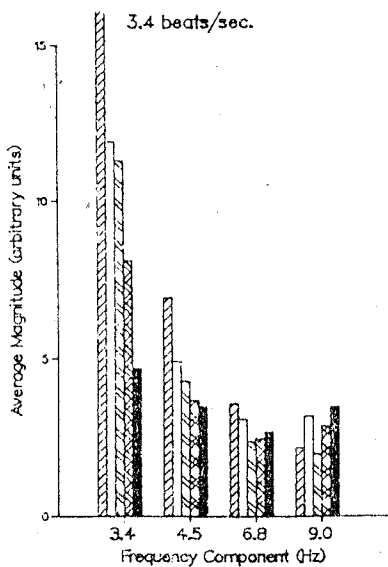

Figure 3 - 13. Average magnitude of EEG frequency components for each electrode placement during photic stimulation (stim. rate as indicated) Subject: G. S.

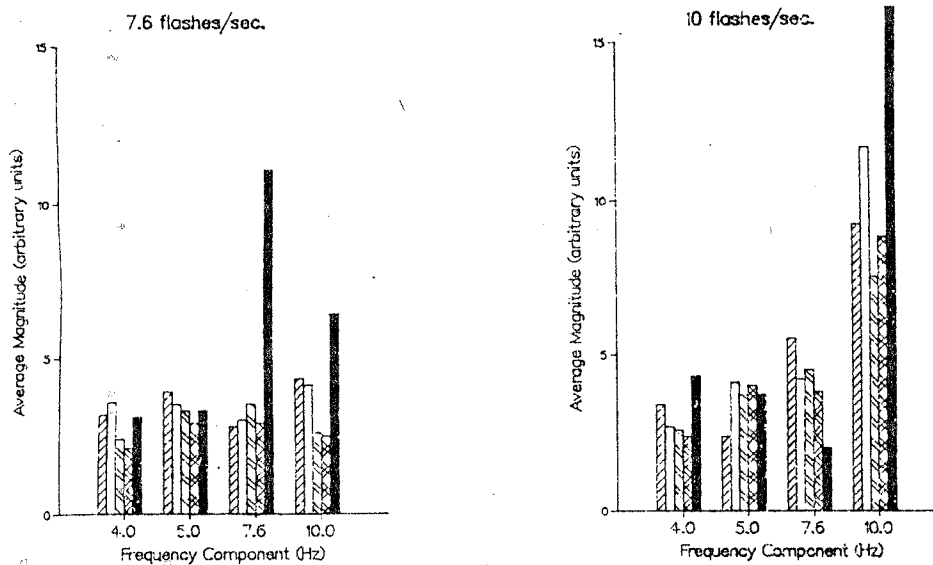
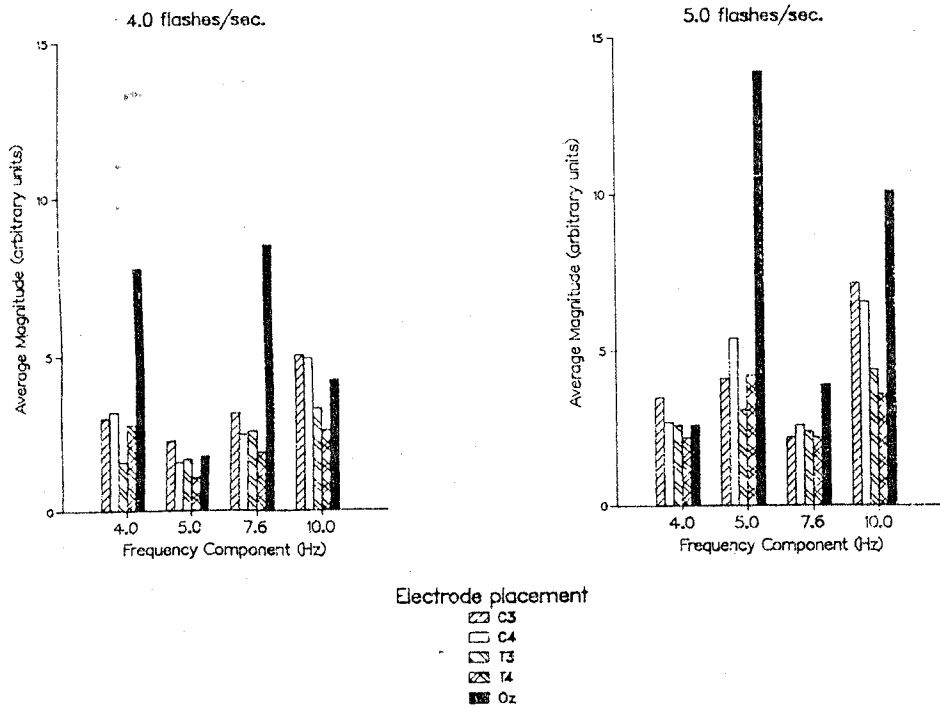

Figure 3 - 14. Average magnitude of EEG frequency components for each electrode placement during photic stimulation (stim. rate as indicated) Subject: D. W.

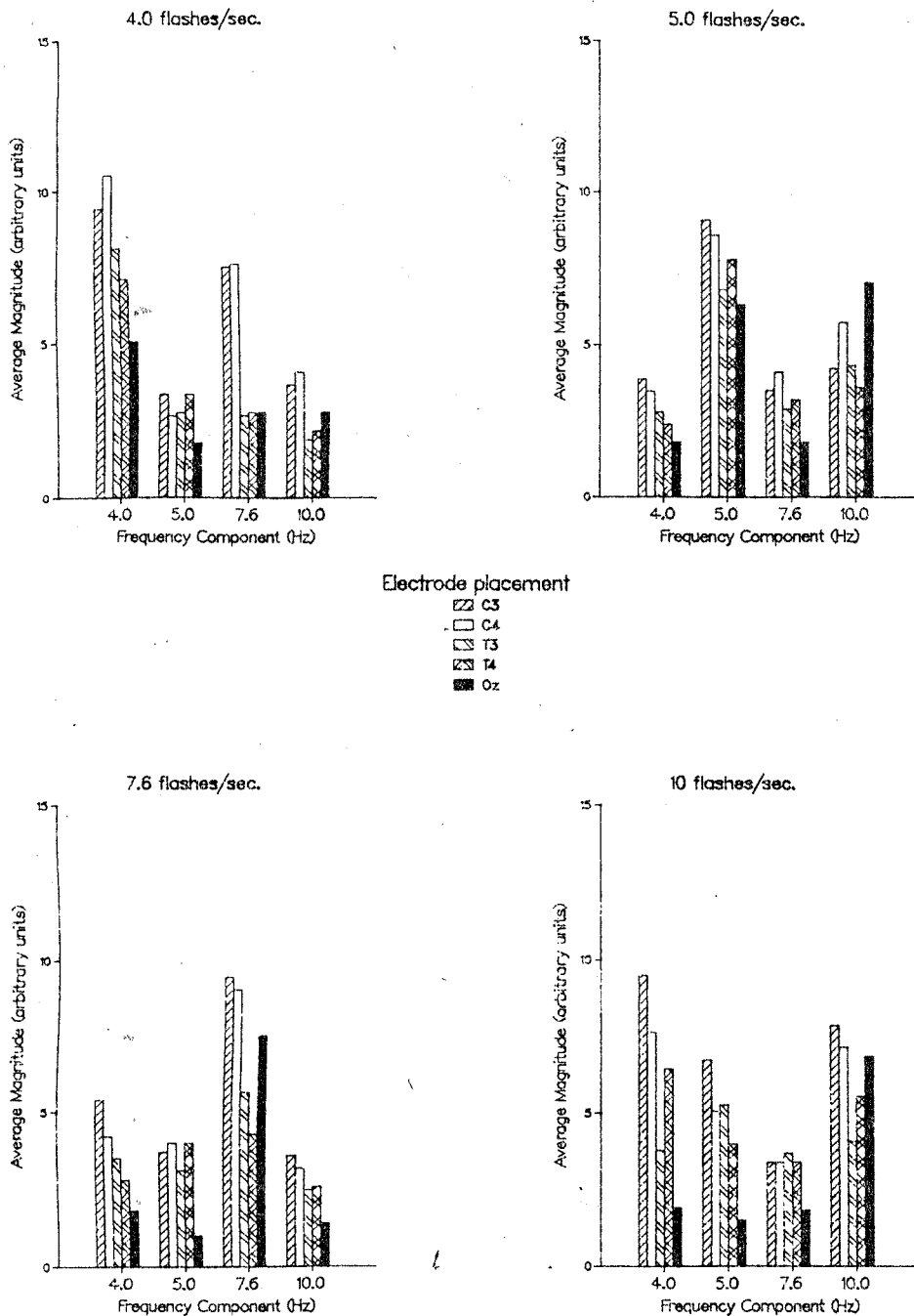

Figure 4 — 1. Frequency analysis (FFT) of EEG for each electrode placement across conditions. (3.8 sec. epoch) Subject: G. S.

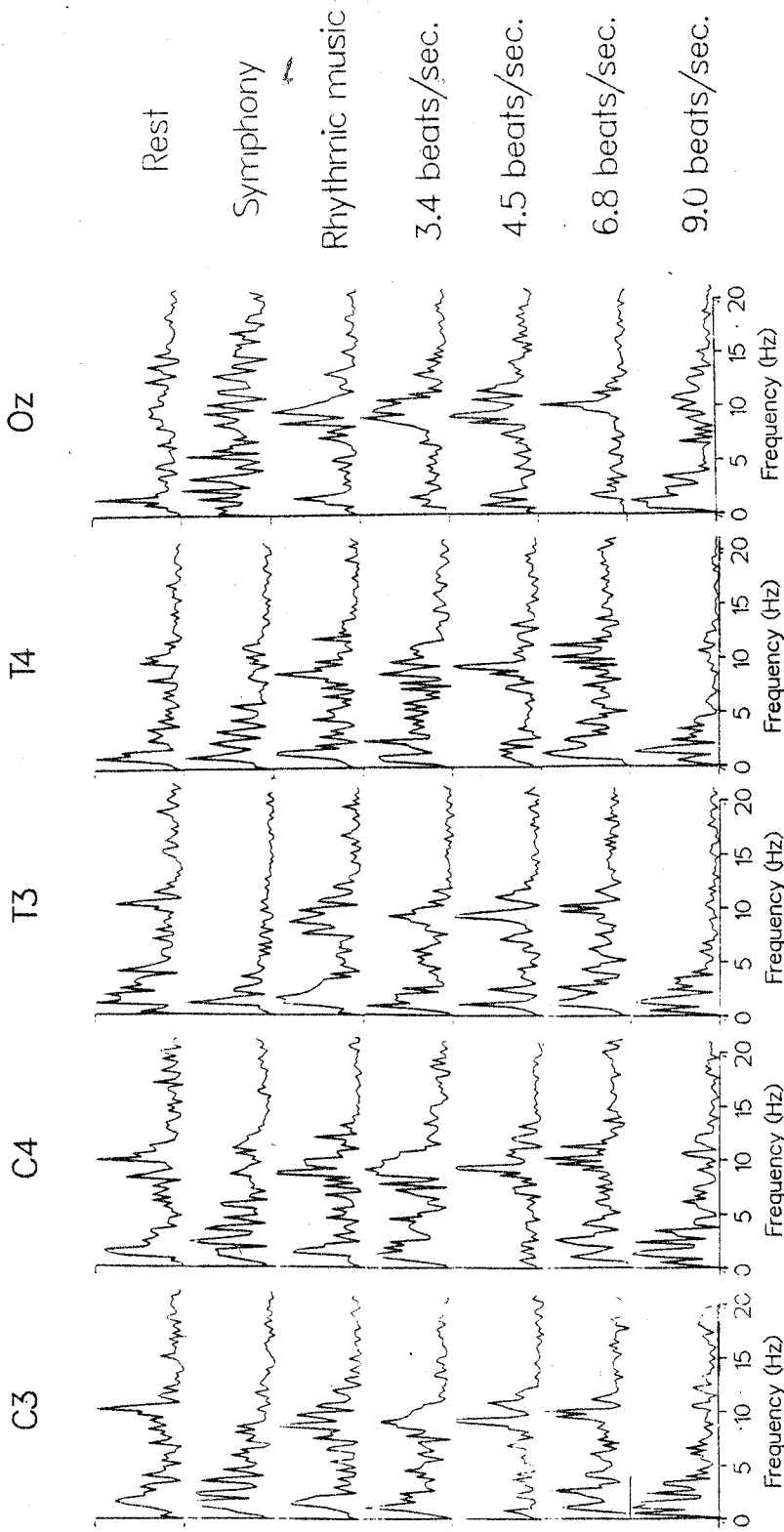

Figure 4 - 2. Frequency analysis (FFT) of EEG for each electrode placement across conditions. (3.8 sec. epoch) Subject: D. W.

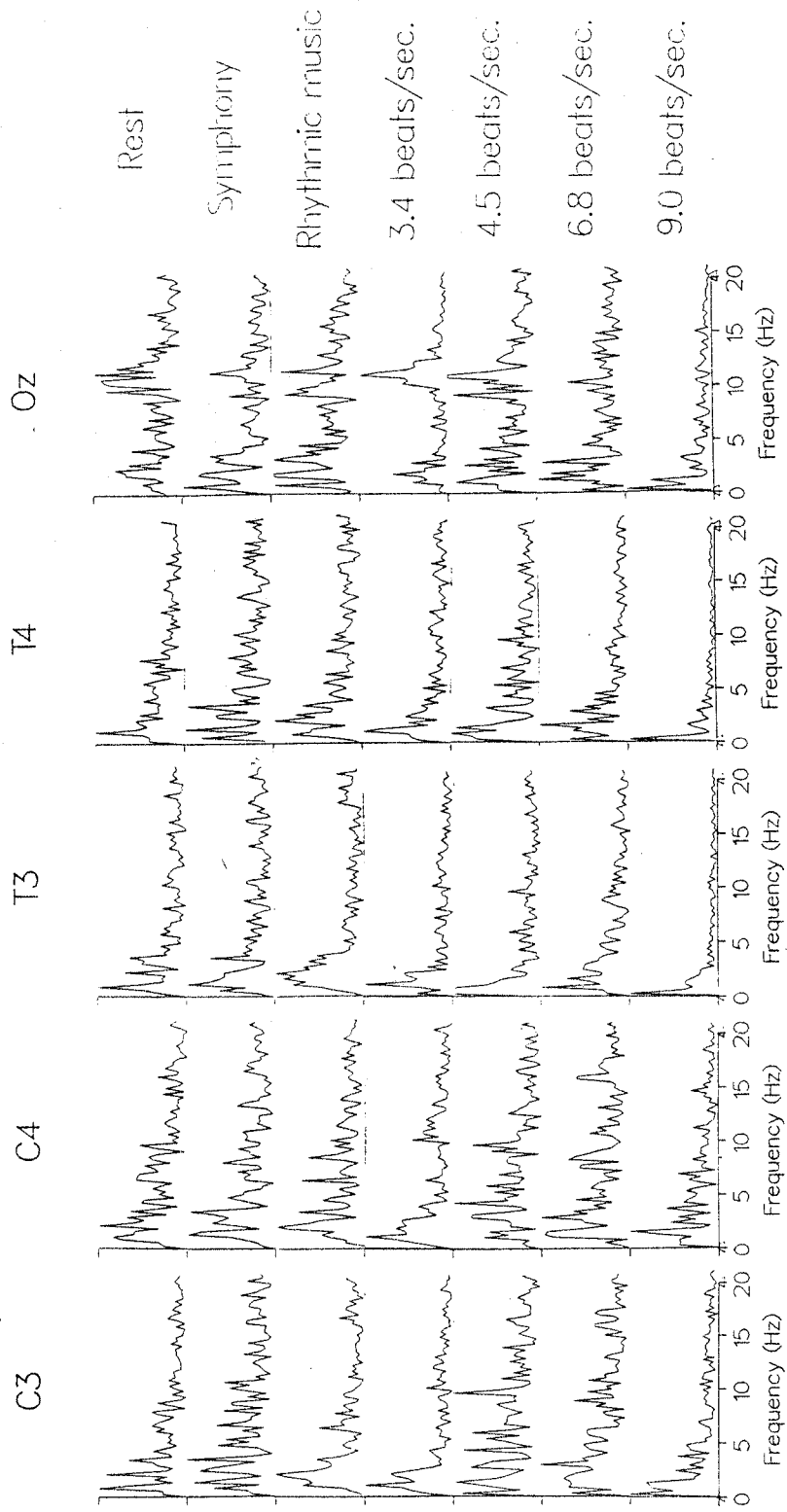

Figure 4 - 3. Frequency analysis (FFT) of EEG for each electrode placement across conditions. (3.8 sec. epoch) Subject: P. R.

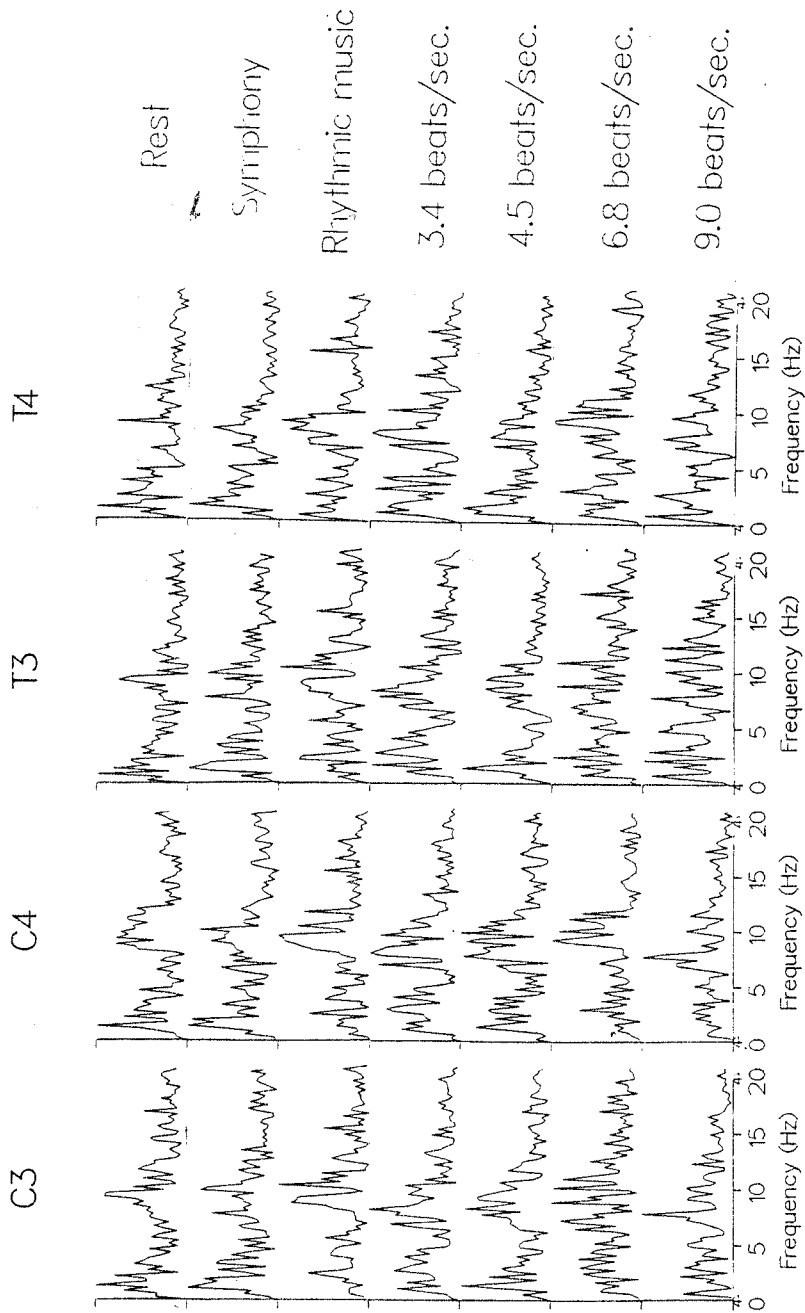

Figure 4 - 4. Frequency analysis (FFT) of EEG for each electrode placement across conditions. (3.8 sec. epoch) Subject: K. W.

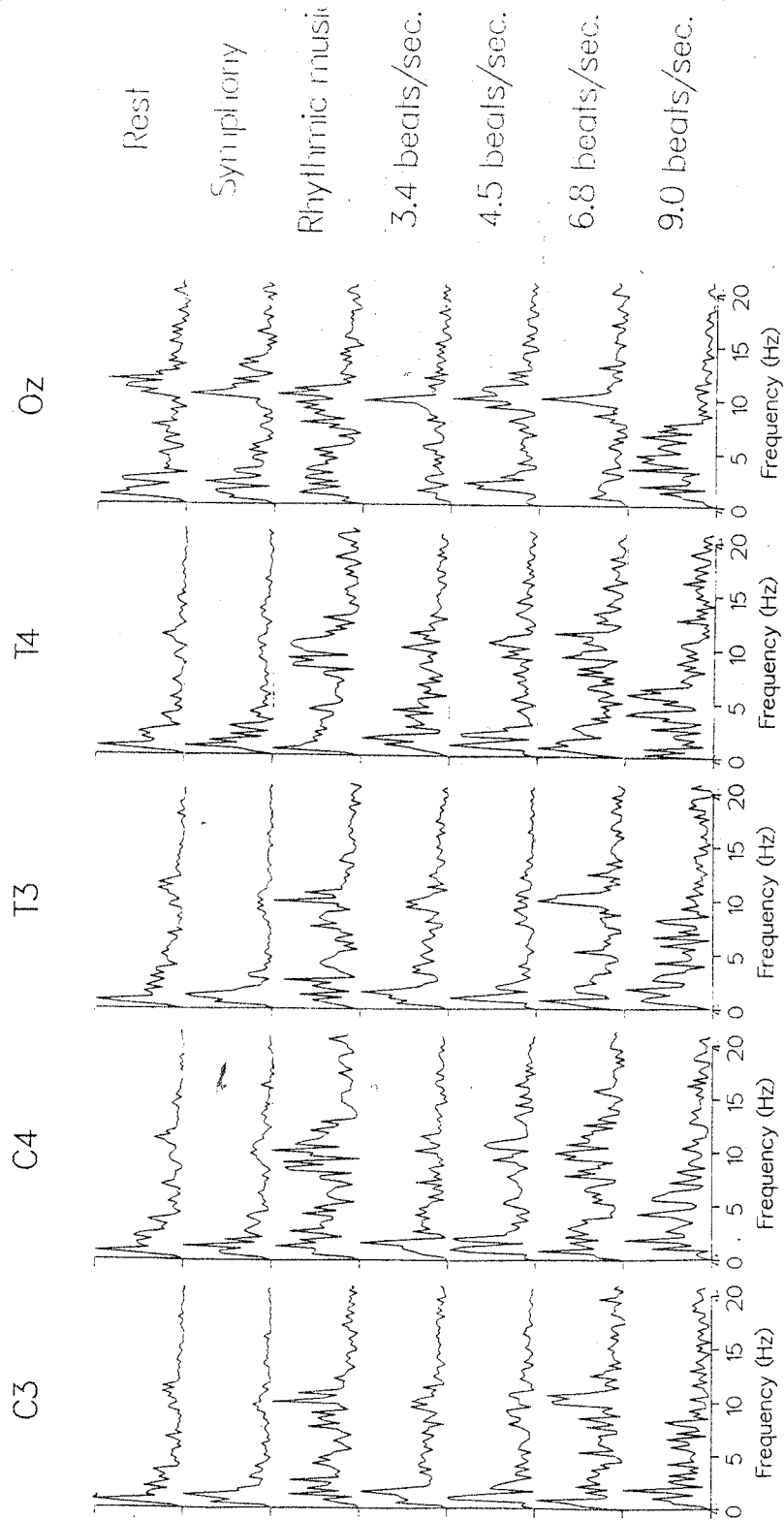

Figure 4 - 5. Frequency analysis (FFT) of EEG for each electrode placement across conditions. (3.8 sec. epoch) Subject: L. R.

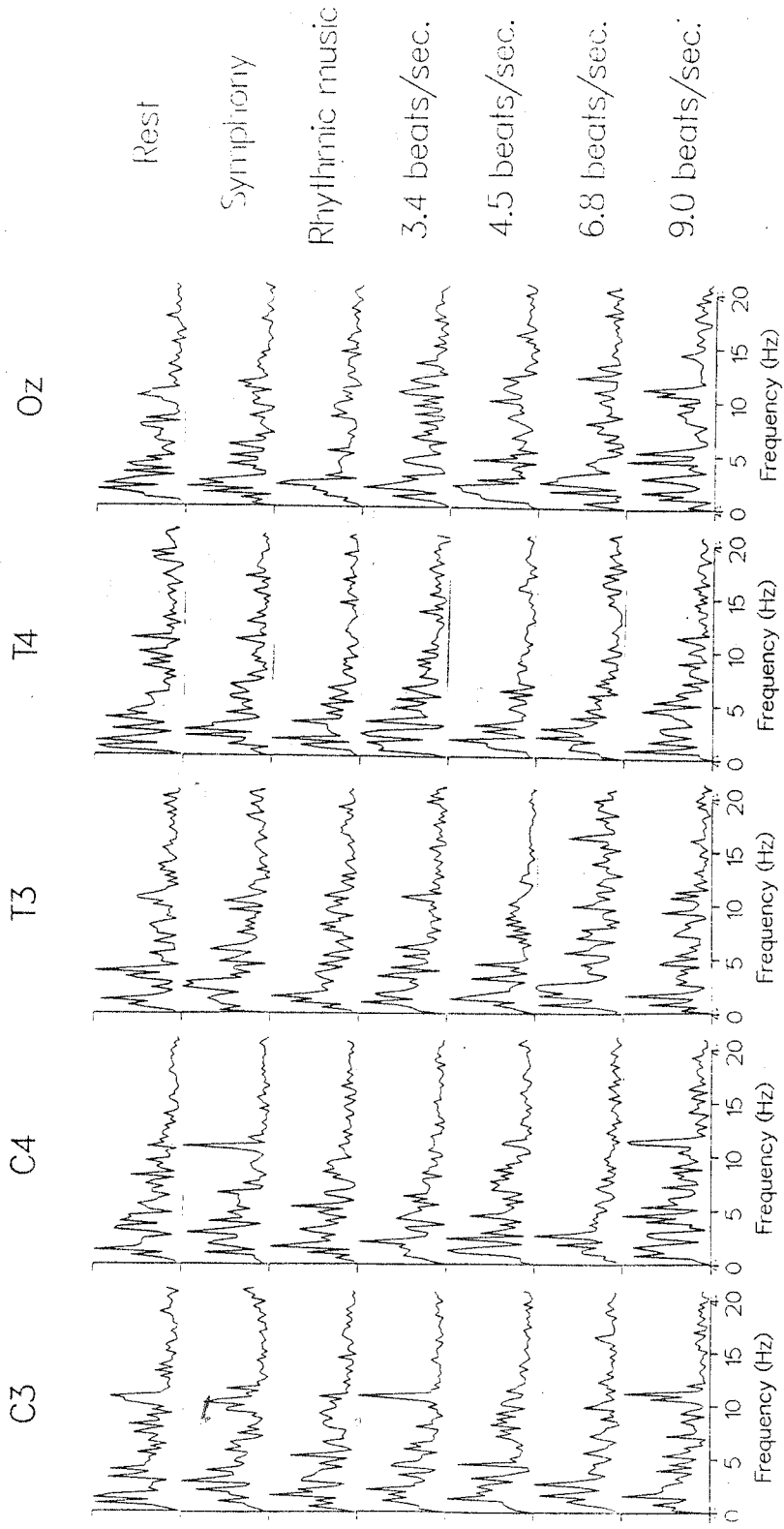

Figure 4 - 6. Frequency analysis (FFT) of EEG for each electrode placement across conditions. (3.8 sec. epoch) Subject: M. G.

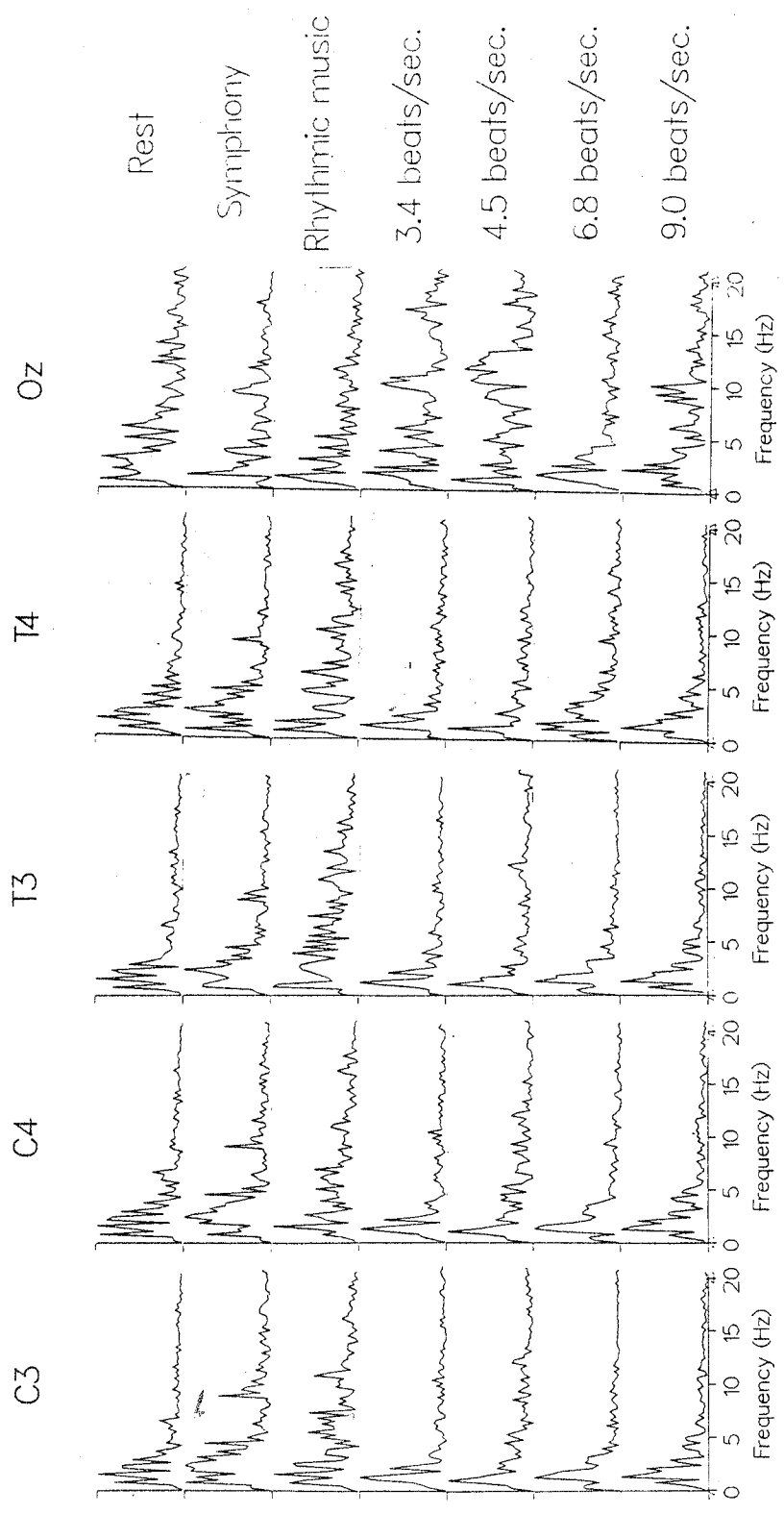

Figure 4 - 7. Frequency analysis (FFT) of EEG for each electrode placement during photic stimulation. (3.8 sec. epochs)
Subject: G. S.

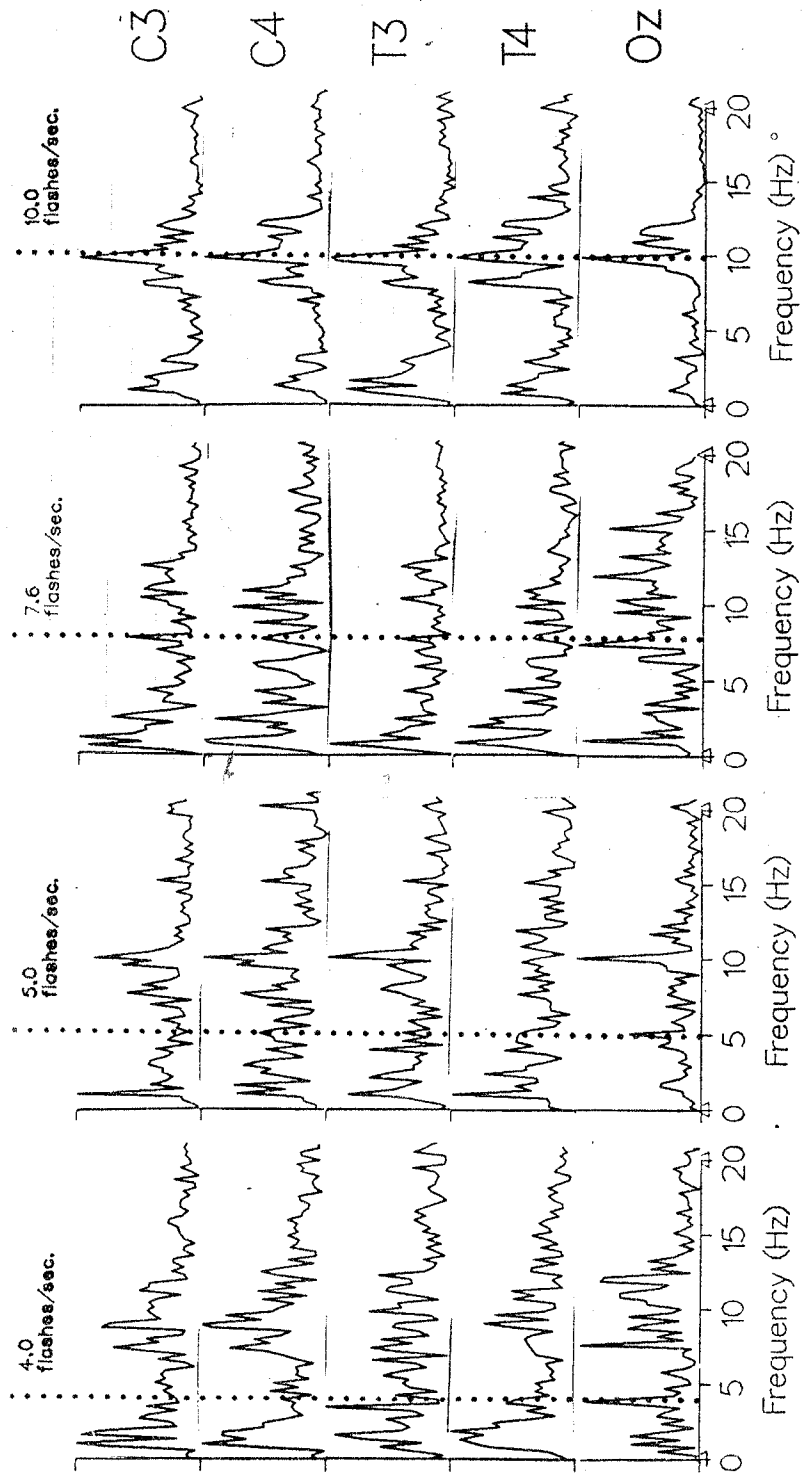
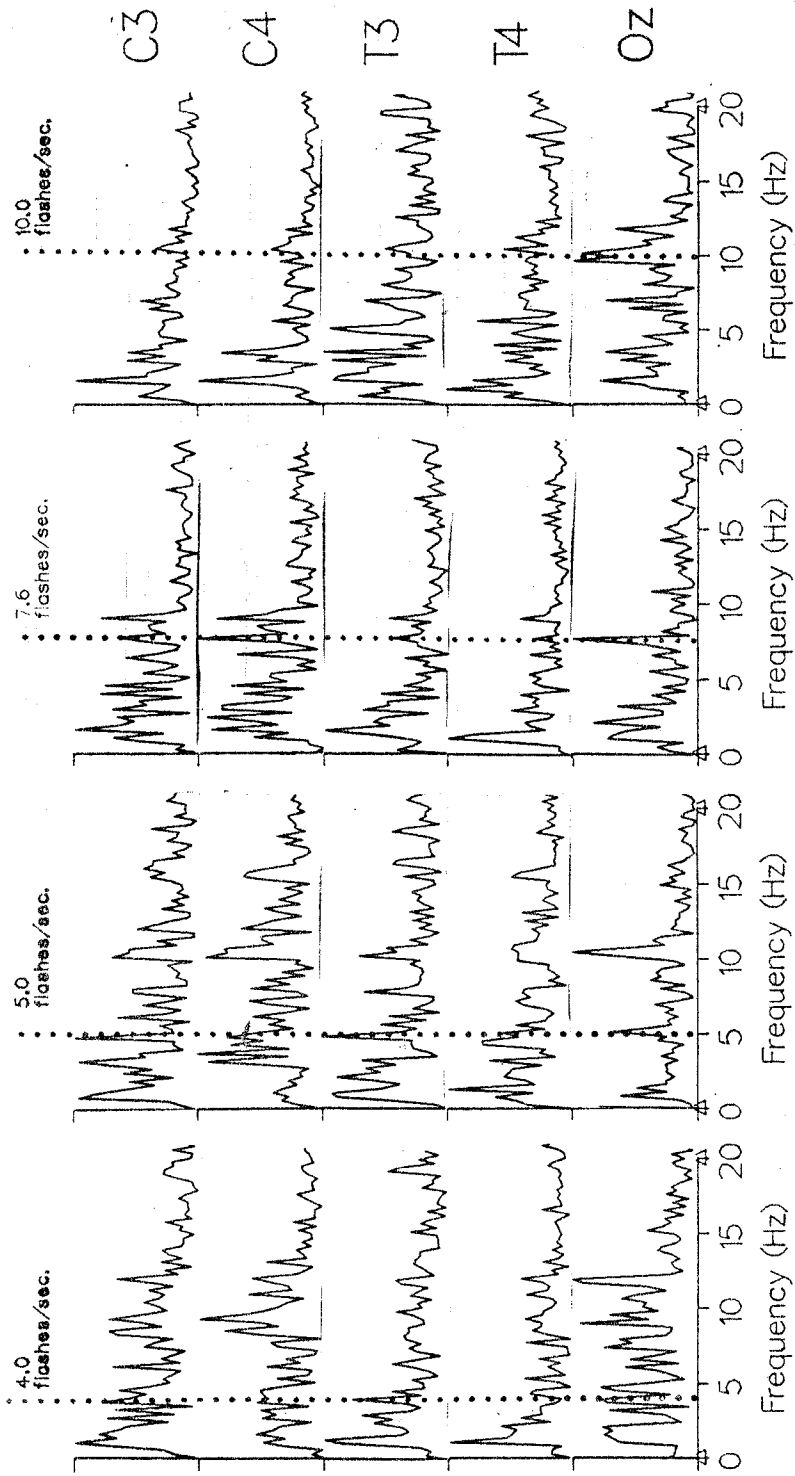

Figure 4 - 8. Frequency analysis (FFT) of EEG for each electrode placement during photic stimulation. (3.8 sec. epochs)
Subject: D. W.



raw data for the photic conditions (Appendix C) but is not discernable in the raw EEG signal during auditory stimulation (Appendix B).

Respiration Rate

Figures 5-1 to 5-8 show respiration rates for each subject for the entire testing session (across conditions). Plots indicate that respiration rate changes markedly within a stimulus condition and varies across subjects. No one consistent pattern of change in respiration can be seen across conditions although respiration appears to be much more stabilized during photic stimulation in both subjects (Figures 5-7 and 5-8) than during auditory stimulation (Figures 5-1 and 5-2 respectively).

Heart Rate

There was no overall change in heart rate across conditions for all subjects. Increases in heart rate variability can be seen to occur at various points throughout the recording session (Figures 6-1 to 6-7).

EMG Data

Rectified EMG signals are plotted with an expanded amplitude scale in order to examine for differential responding of muscle units controlling hand movements while subject is at rest, listening to rhythmic sounds, or tapping one hand to the rhythmic sounds. Although no overall patterns of muscle activity aside from the large potentials synchronous with rhythmic hand movements were observed in the amplified EMG signals there were differences noted in the EMG signal of the arm at rest while the contralateral arm was engaged in tapping or was at rest.

Figure 5 — 1: Average respiration rate across conditions
 Subject : G. S.

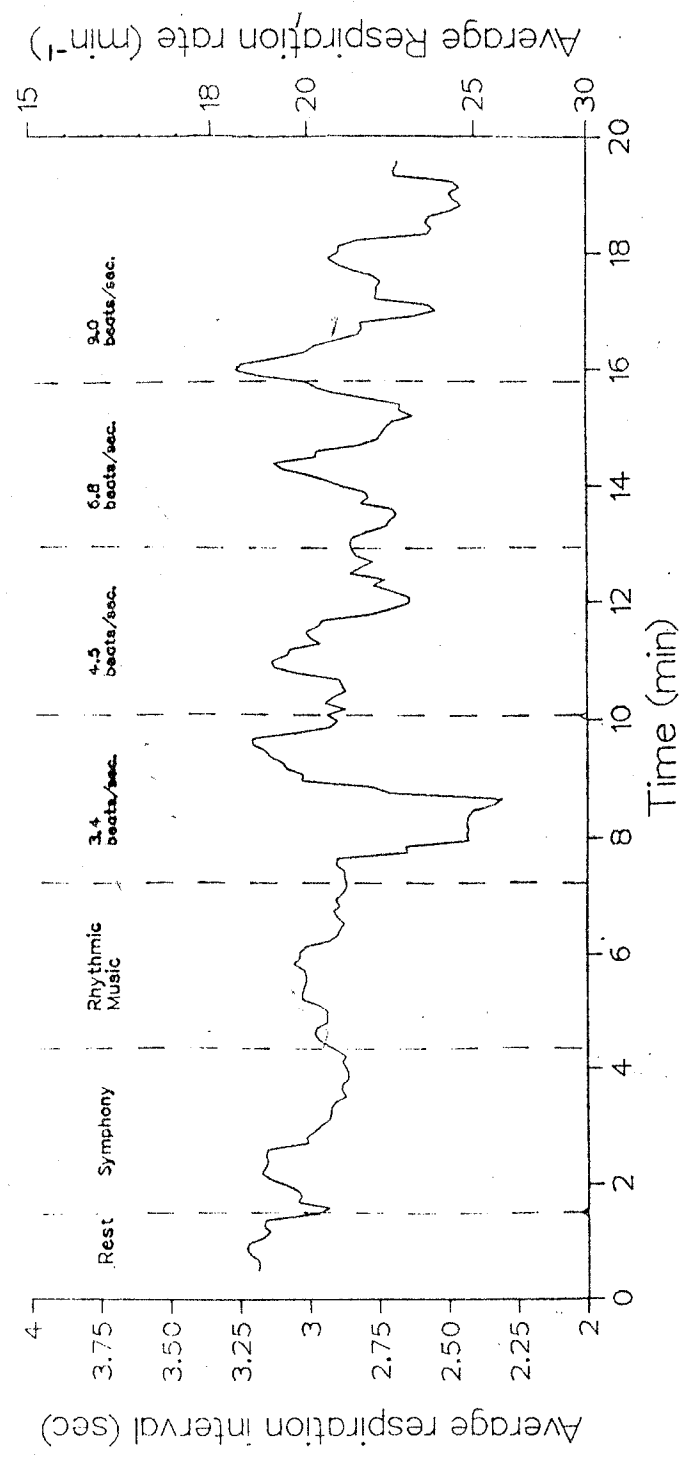

Figure 5 - 2. Average respiration rate across conditions
 Subject : D. W.

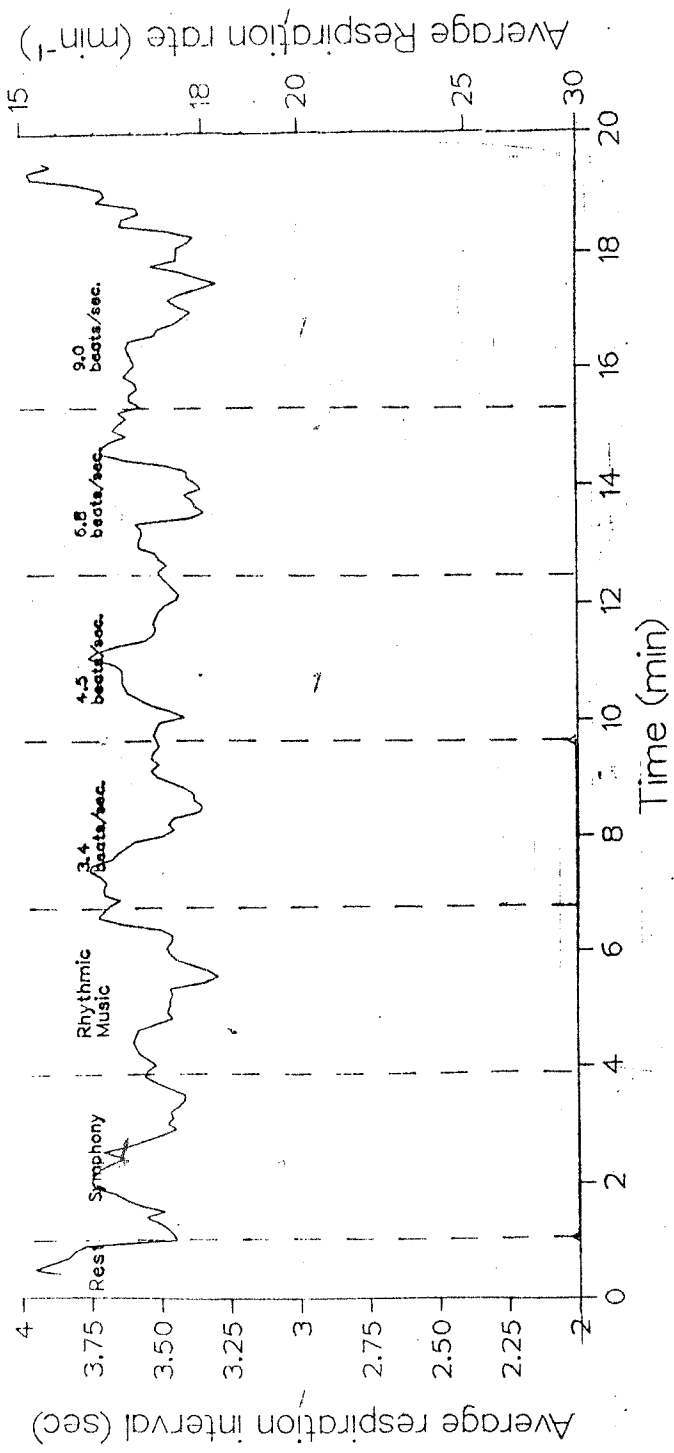

Figure 5 - 3. Average respiration rate across conditions.
 Subject : P. R.

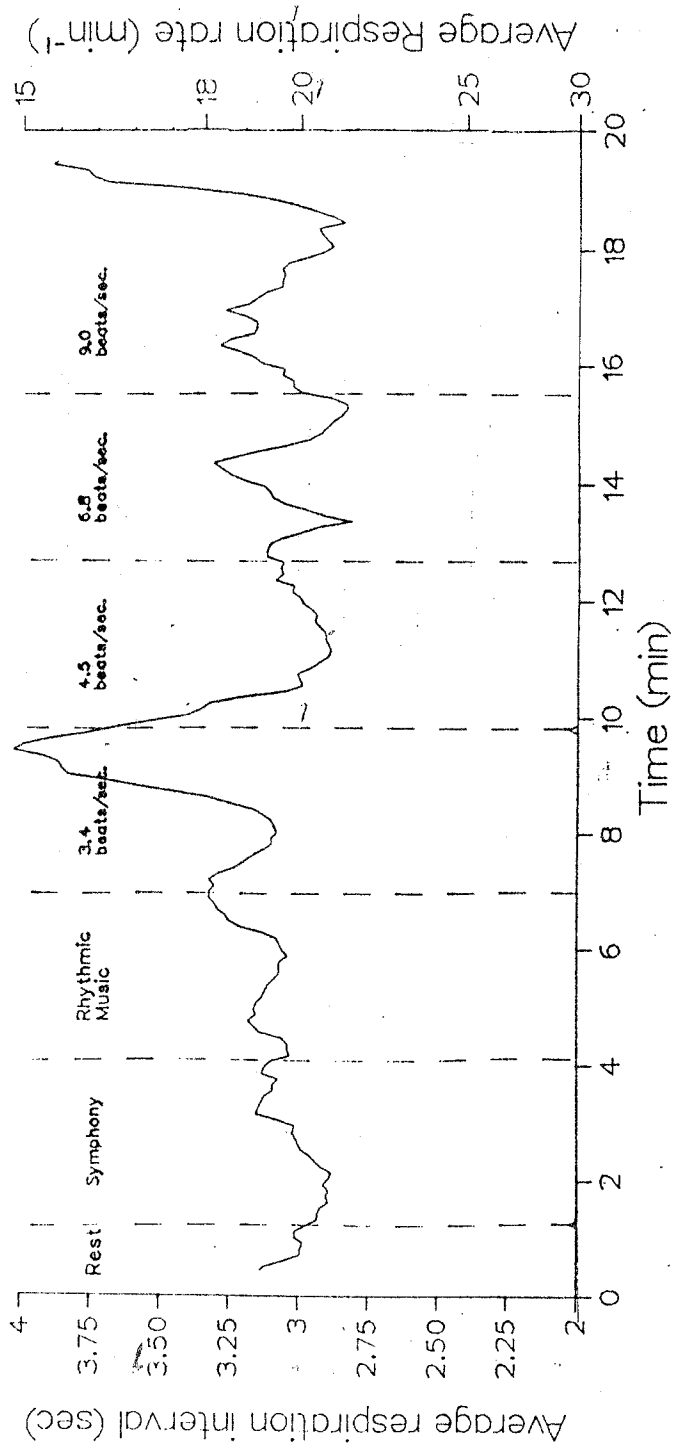

Figure 5 - 4. Average respiration rate across conditions
 Subject : K. W.

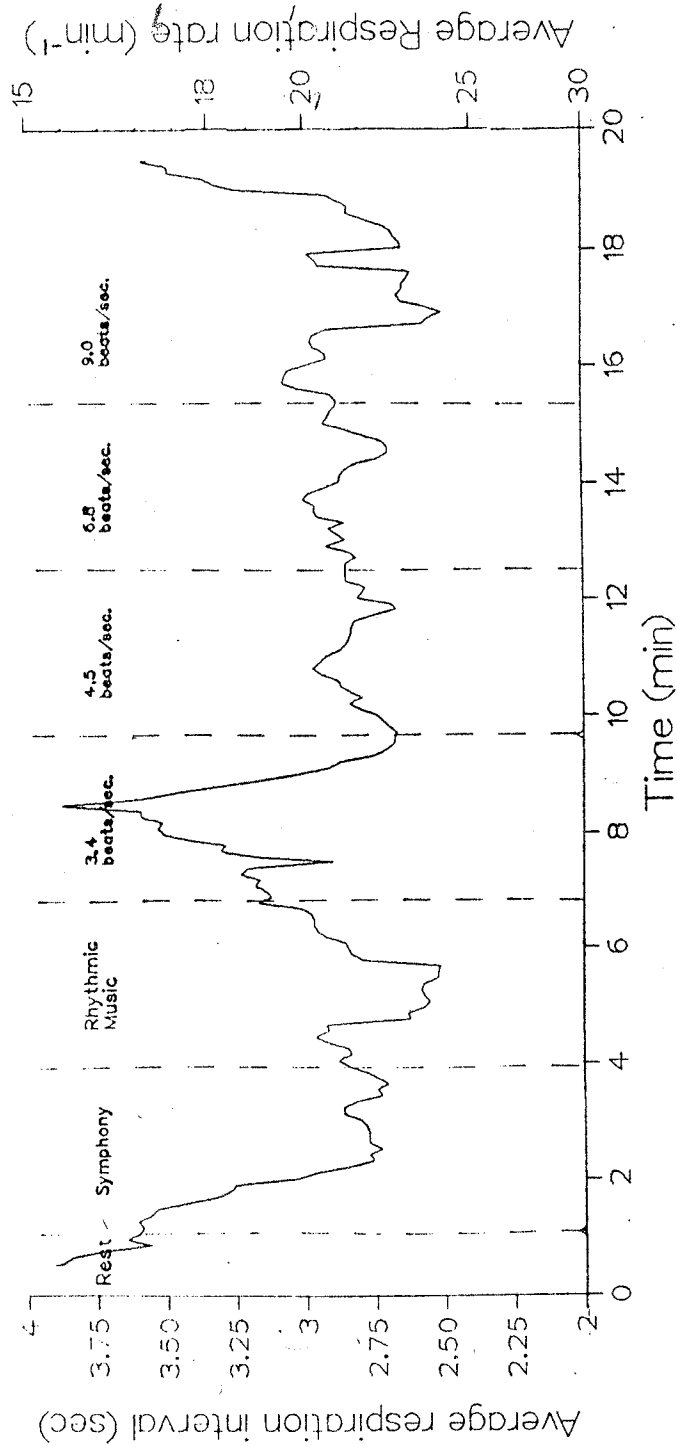

Figure 5 - 5. Average respiration rate across conditions
 Subject : L. R.

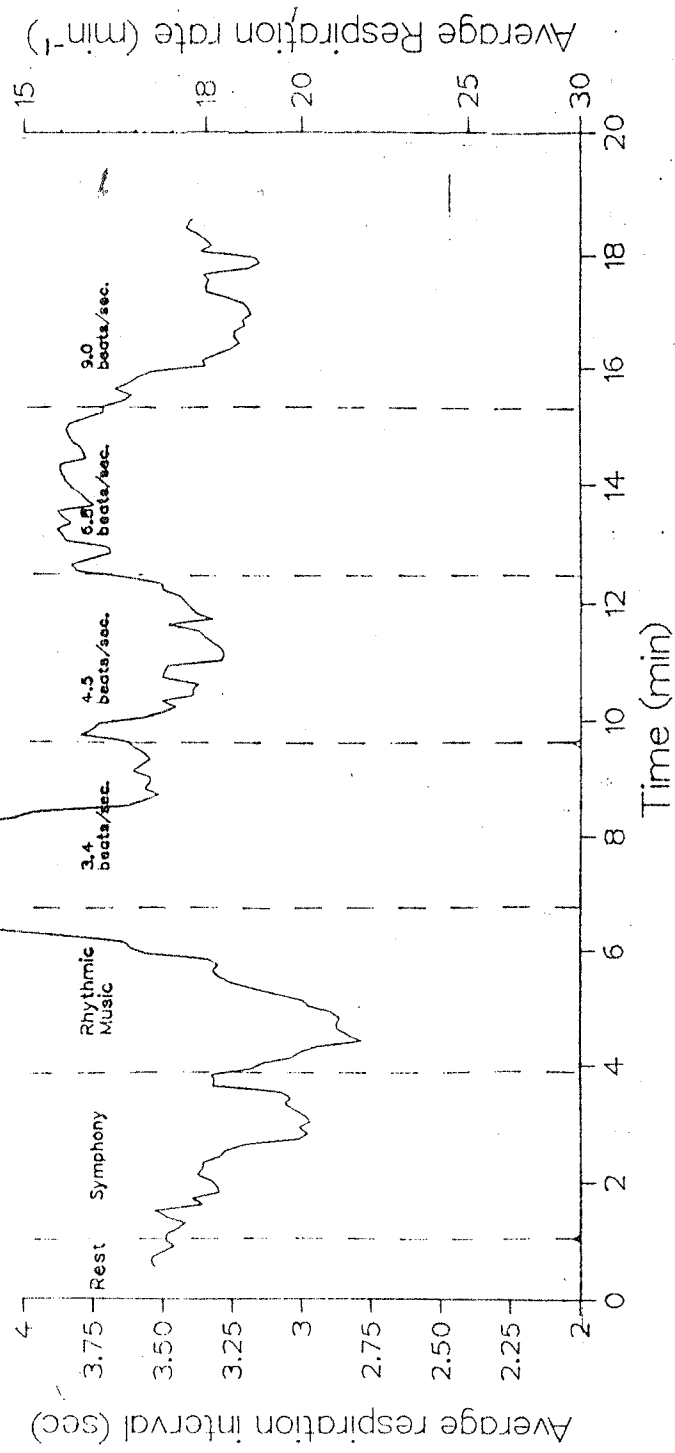

Figure 5 — 6. Average respiration rate across conditions
 Subject : M. G.

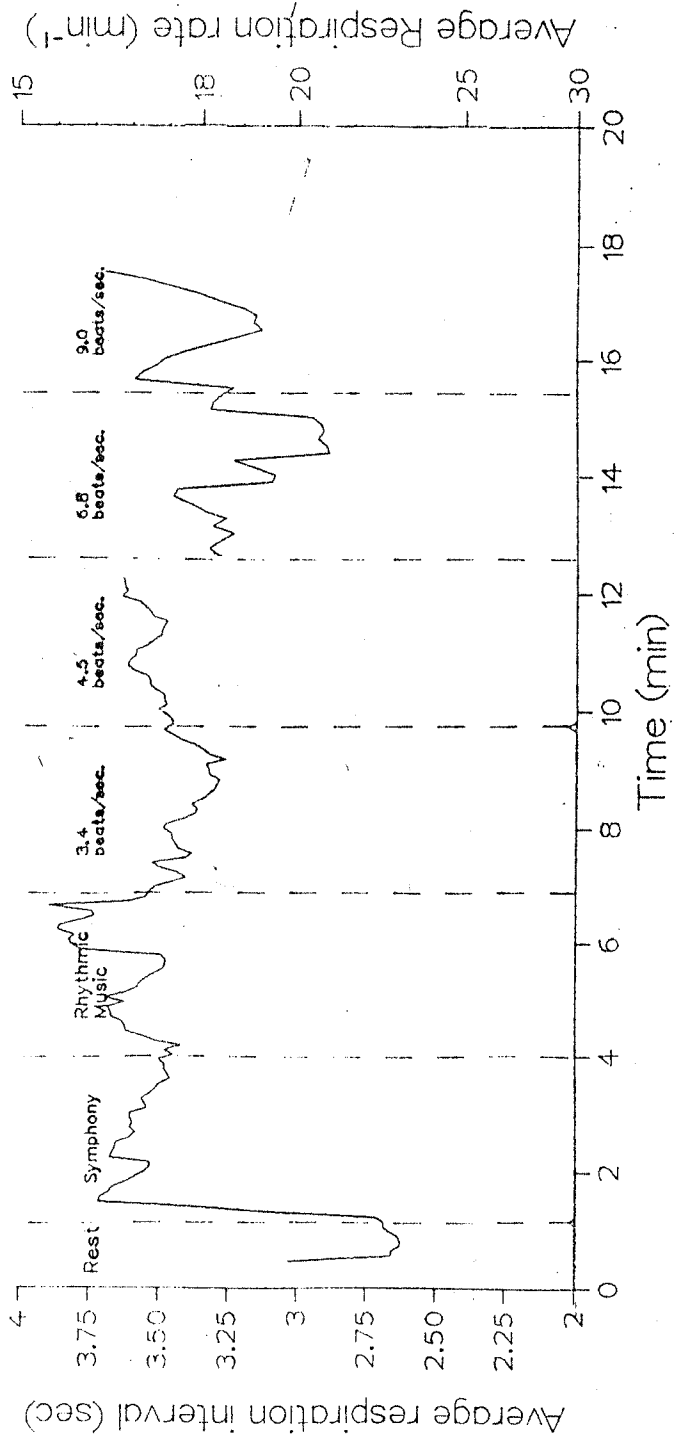

Figure 5 - 7. Average respiration rate across conditions during photic stimulation. Subject : G. S.

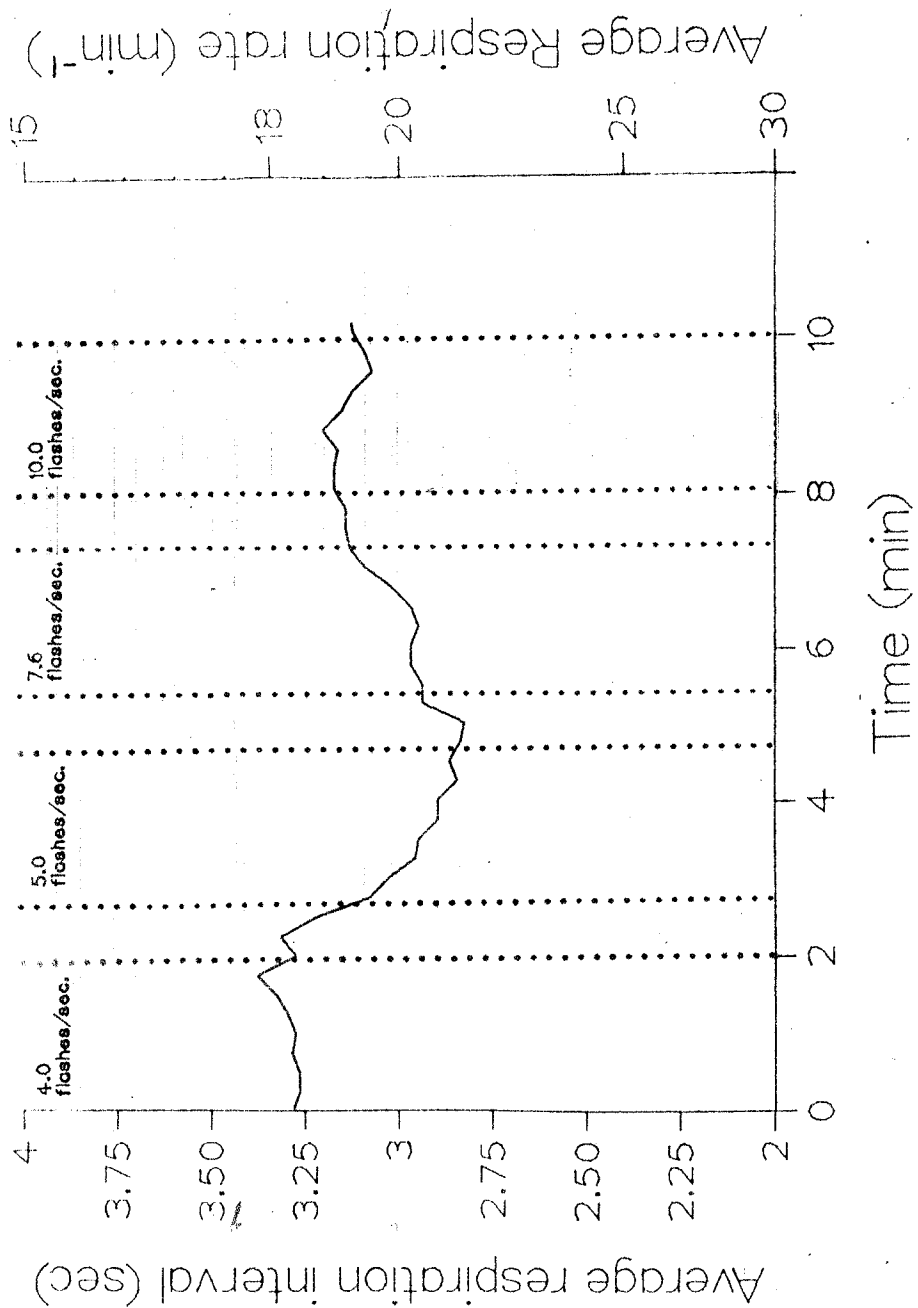

Figure 5 – 8. Average respiration rate across conditions during photic stimulation. Subject : D. W.

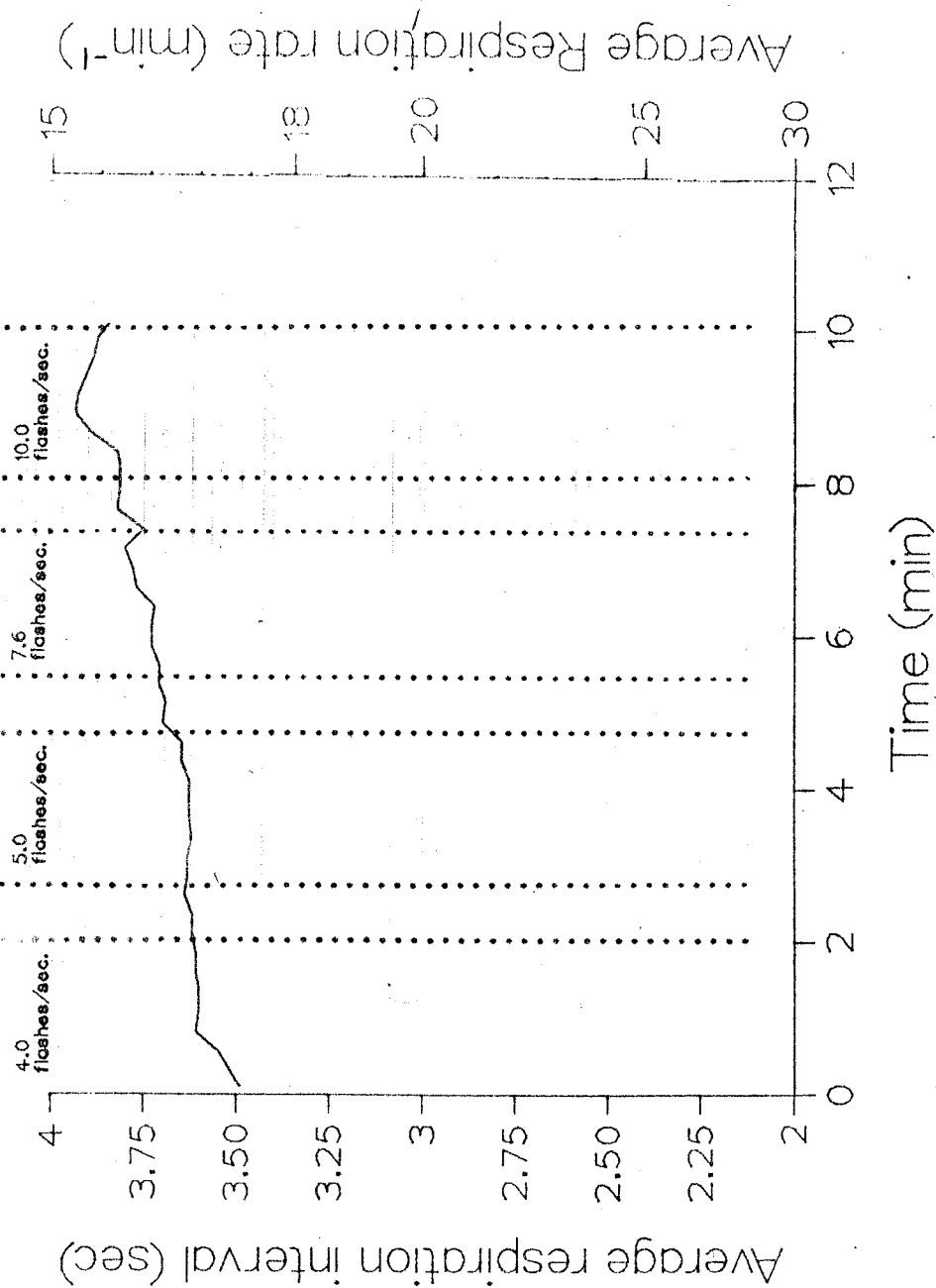

Figure 6 - 1. Average heart rate across conditions
 Subject : G. S.

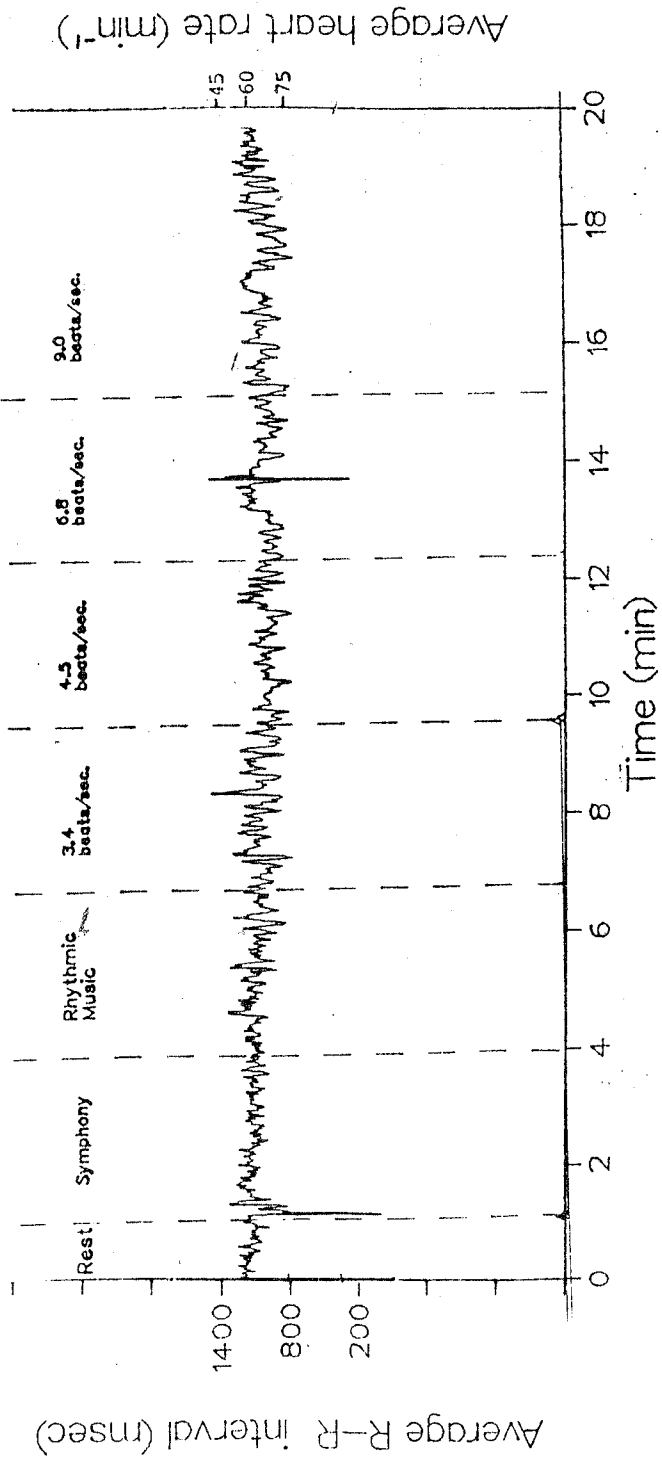

Figure 6 - 2. Average heart rate across conditions
 Subject : D. W.

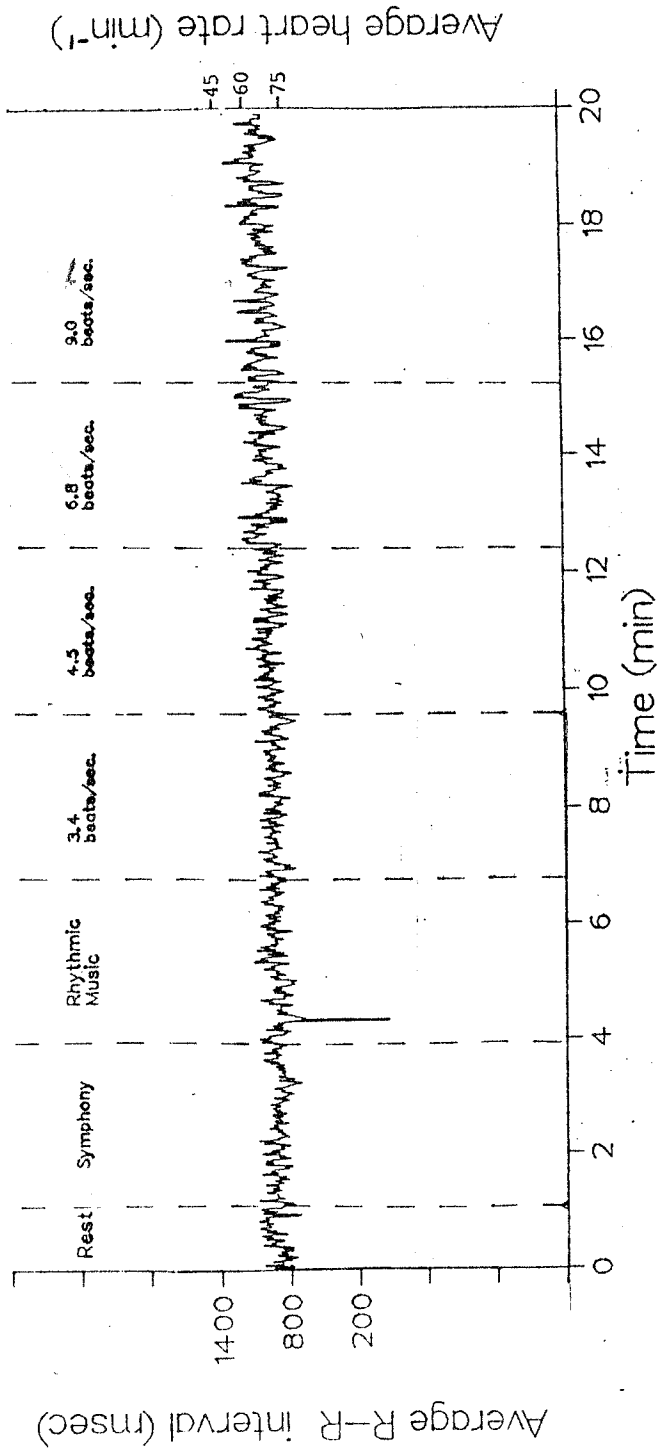

Figure 6 -- 3. Average Heart Rate across conditions
 Subject : P. R.

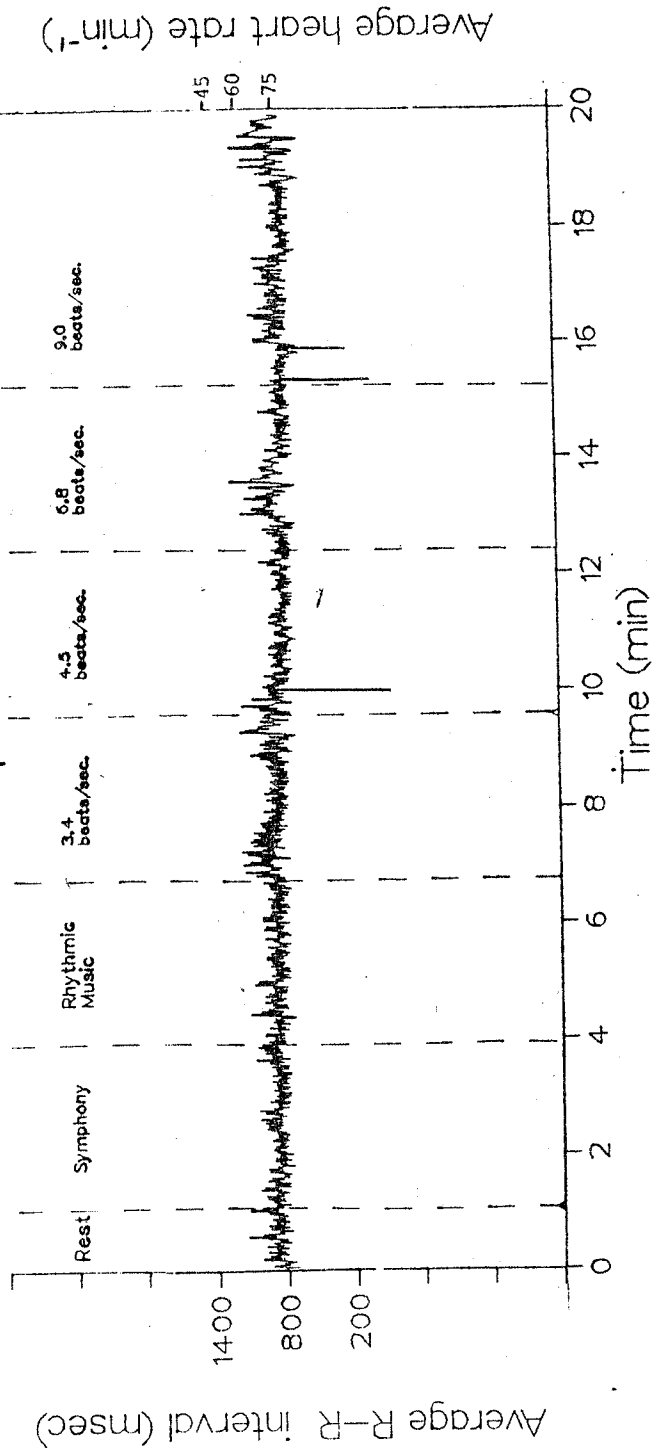

Figure 6 - 4. Average Heart Rate across conditions
 Subject : K. W.

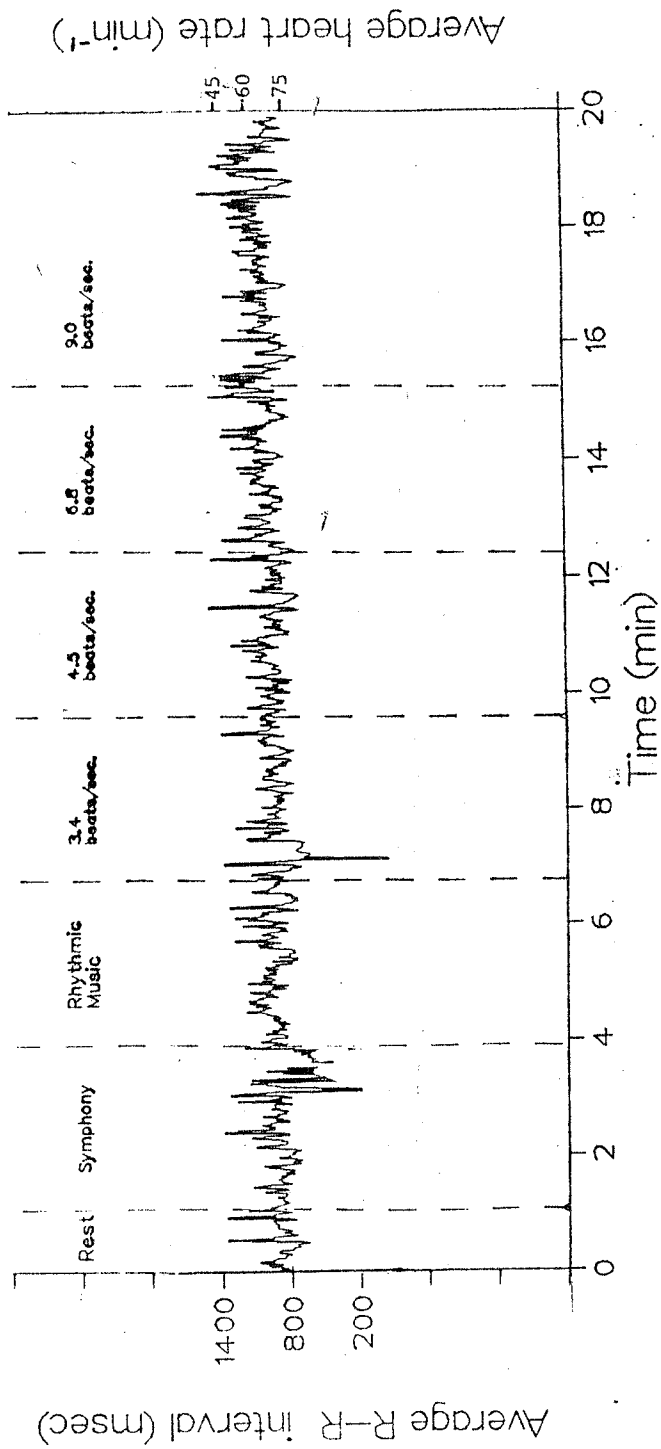

Figure 6 - 5. Average Heart Rate across conditions
 Subject : M. G.

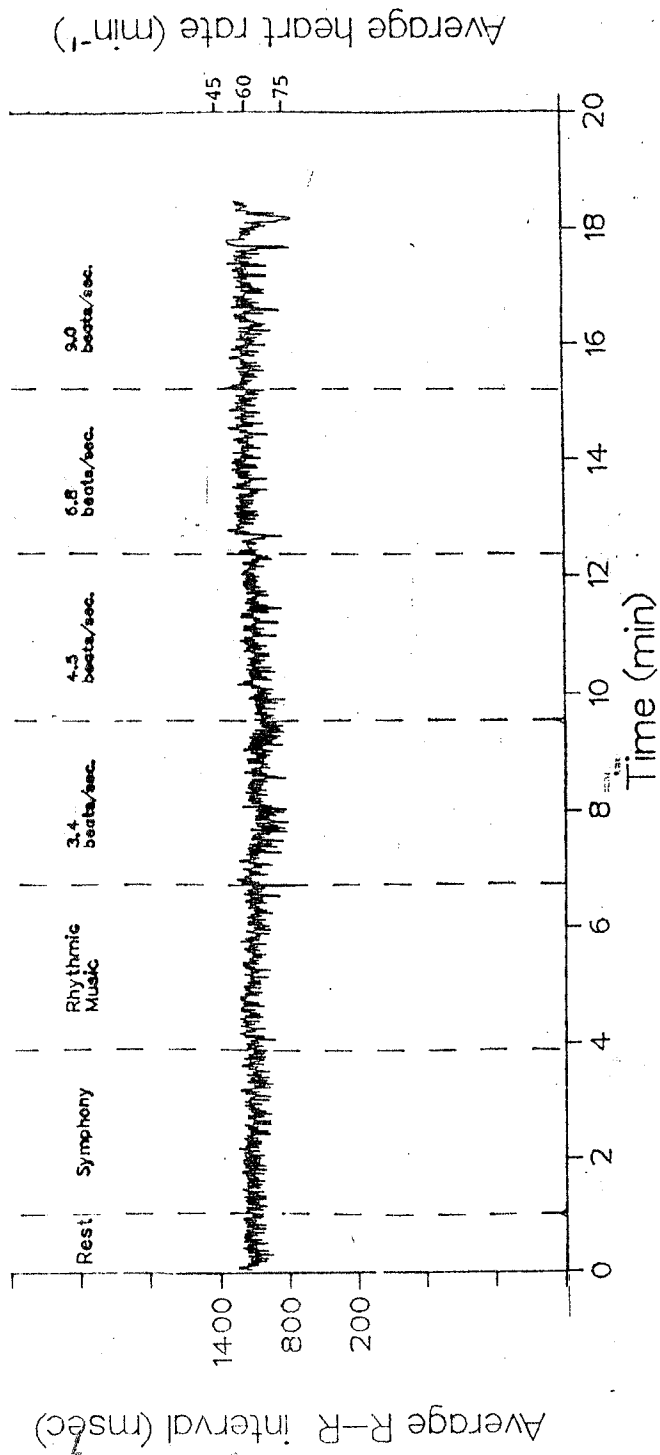

Figure 6 — 6. Average heart rate across conditions during photic stimulation. Subject : G. S.

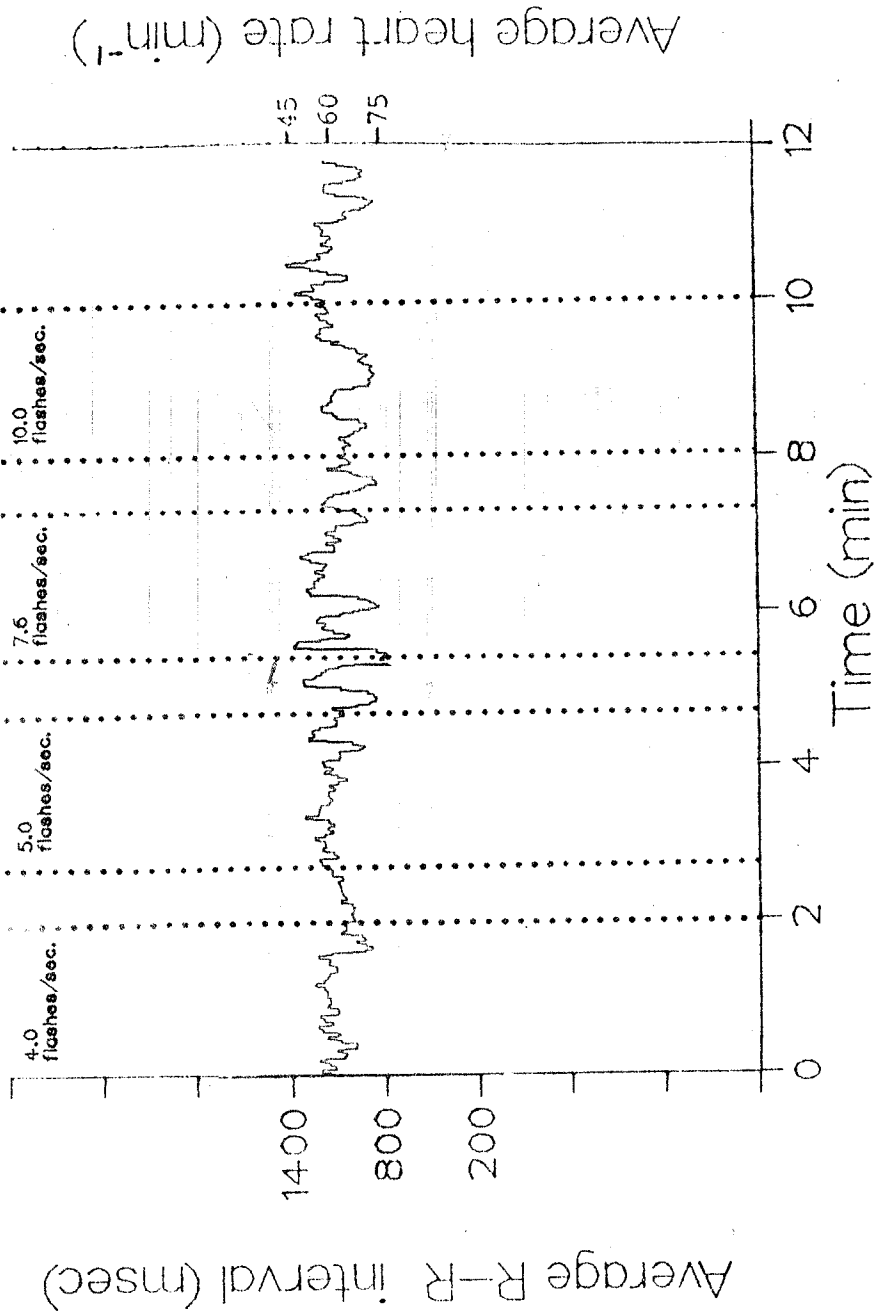
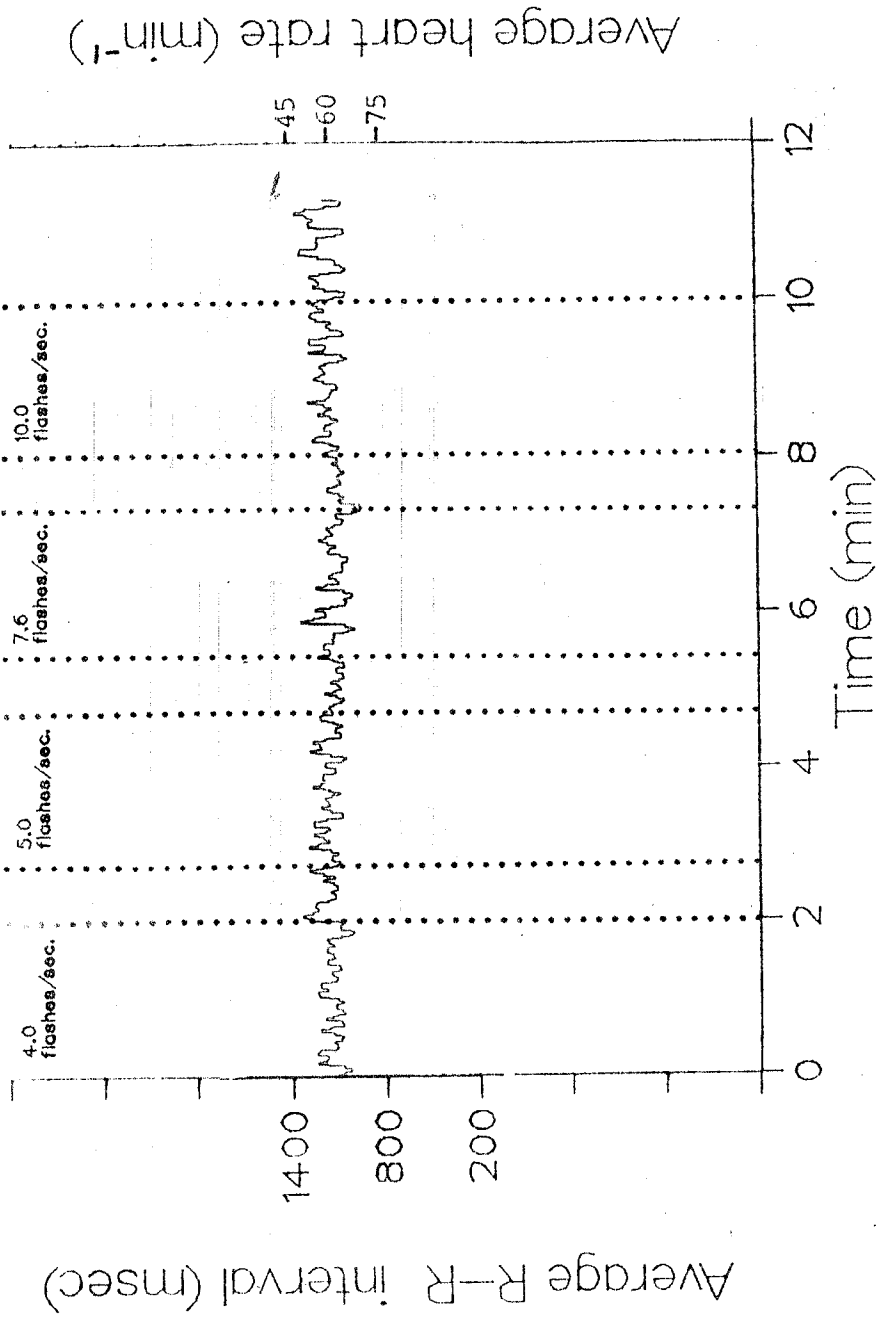

Figure 6 - 7. Average heart rate across conditions during photic stimulation. Subject : D. W.



5

D. Discussion

Examination of EEG recordings during presentation of rhythmic auditory stimulation indicated that there was no presence of auditory driving in terms of increased presence of frequencies in the EEG corresponding to the stimulus frequency in any of the subjects tested. Consequently, it was not possible to make comparisons across measures with regard to the rates of auditory stimulation used (eg., cross-correlation between the EEG signal and auditory signal). Frequency analysis of the EEG signal did not detect any increases in frequency components (that might not be observable in the continuous records) even with repeated stimulation at high intensity levels for durations of up to 3 minutes. It was not apparent that auditory stimulation in the "theta" range (3.5 - 7 Hz) was any more effective than other frequencies in producing changes in the psychophysiological measures taken. However, photic stimulation at similar frequencies was capable of producing clear driving effects with stimulus durations of less than one minute. These can be seen in the continuous plots of EEG for stimulation at 10 flashes per second and in the FFT spectral plots for all rates as prominent peaks in the distribution, even when these spectral plots represent very brief epochs of data (3.84 seconds). Thus, it can be assumed that such analysis techniques would have been capable of detecting auditory driving effects if they had been present.

In examining some of the FFT spectra it can be seen that there is in fact a decrement in the amount of 9.0 Hz activity

5

during stimulation at 9.0 beats/second compared to lower rates (eg., Figure 4-2) a result totally opposite to what would be predicted from other studies, namely that auditory driving would be elicited most easily at stimulation at rates within the range of alpha activity (8 - 12 Hz).

Differences in the overall distribution of power in the frequency spectra of EEG recordings can be seen across different conditions of stimulation as well as across individuals. The relative amount and frequency of spontaneous alpha activity differs across individuals as can be expected and predominates in the Oz electrode position. (It is interesting to note here that photic driving at 10 flashes/sec was somewhat more pronounced in one subject (G. S.) whose resting alpha rate was closer to 10 Hz.). Some subjects appear to have increased alpha activity during the rhythmic instrumental piece compared to the other control conditions (rest and symphonic music). The fact that the rhythmic selection was a slower more 'relaxing' form of music may account for this effect.

One difficulty encountered in the interpretation of the EEG data was the presence of muscle artifact contamination of the temporal electrode placements (T3 and T4) in many subjects. It is not known whether this was a myogenic response to the auditory stimulation similar to the so-called 'sonogenic' responses reported by Bickford et al. (1964) or simply spreading contamination from tension in masseter and temporalis muscles in the subjects occurring throughout the experimental procedure. The

response appeared in some subjects and not others. Therefore, the use of temporally placed electrodes for recording of this nature may not be suitable unless care is taken to reduce these artifacts.

Respiration recordings taken over the duration of the experimental session indicate that there is a large amount of variation within each stimulus condition although no overall pattern of change in relation to the different rates of auditory stimulation (eg., respiration rate does not increase with increased rate of stimulation). Some subjects showed a sudden increase or decrease in breathing rate at the beginning of a new stimulus rate indicative of an orienting response to a change in stimulus frequency. This effect may give the respiration recordings their cyclical appearance over the duration of the experiment.

Although this study attempted to examine psychophysiological responses to naturalistic stimuli under relatively controlled conditions some difficulties with this approach were noted:

(i) The use of tape recorded sounds enabled greater control over the stimulus (tape loops were used for the repetitive drumming sounds in order to reduce fluctuations in the rate of beating and to standardize the stimulus across individuals) however, this results in the loss of lower frequencies (below 25-30 Hz) which are normally present in the stimulus. This may be particularly important in the case of drumming sounds in which

there is a significant amount of somesthetic stimulation from the vibrations produced by the drum. This should be taken into account in those studies in which actual drums are used as the eliciting stimulus (eg., Neher, 1961) or studies which wish to examine the effects of such sounds as they would normally occur in the environment.

(ii) The setting in which this type of stimulation occurs has been noted as an important factor in the production of central nervous system effects. This creates difficulties in measuring physiological responses which are free from artifacts and excessive noise while not interfering with the subjective state, mood, or attentiveness of the subjects. For example, it was found that the use of a repetitive or monotonous stimuli in a situation where the subjects are required not to move results in the inability of the subjects to remain alert over long periods of recording. Most of the subjects tested reported to feel drowsy towards the end of the recording session, although interestingly respiration and heart rate does not decrease over this period time for any of the subjects tested. (In one case a subject reported that they perceived their breathing rate to increase with the rate of beating, however the respiration records show no overall change over these conditions for that subject.) This indicates that individuals may have inaccurate perceptions of their bodily reactions to auditory stimulation of this nature.

(iii) Fourier analysis methods, such as the FFT algorithm, are suitable for analysis of biological signals in the time domain and allow the detection of consistent frequency components in the signal without signal averaging techniques (which would require a much more controlled stimulus). However, some difficulties are encountered in the interpretations of FFT analyzed signals. Since the magnitude of a given frequency component in the FFT is relative to all other frequencies included in the FFT calculation, the presence of large unwanted components in the signal can make comparisons across subjects and conditions difficult by changing the distribution of power in the FFT spectrum. For example, a large d.c. component in the EEG signal due to electrode polarization or low frequency components produced by eye movements may "mask" the strength of frequencies in the range of interest. This can be seen in one subject who produced a large number of eye blinks resulting in the power being shifted to the lower end of the spectrum (Figure 4-6).

The results of this study do not confirm Neher's (1961) findings although some differences between the two studies may account for the conflicting results. Neher used an actual drum as the sound source and as noted earlier this may account for additional stimulation of the subject. (Neher's subjects also produced excessive eye blinking which may have produced biased estimates of EEG activity as well.) More importantly, Neher reports all of his subjects experienced perceptual distortions

during the experiment -- an effect that was not observed in this study. Earlier studies have reported auditory driving to occur in epileptic patients only indicating that auditory entrainment may be closely associated with extreme behavioural changes.

It may be concluded from this study that overt auditory driving responses are not readily produced in subjects in standard laboratory conditions. It also appears that the conflicting reports from earlier studies on the ability to elicit auditory entrainment of brain rhythms may not be solely due to the kind of stimulus used but rather a number of other factors that have yet to be determined. The fact that photic driving was achieved under the same conditions within the same subjects demonstrates that if setting and behavioural state of the subject are important factors for successful auditory driving they are not critical for entrainment with photic stimuli.

It remains unclear however, as to whether other physiological changes are necessary in order to facilitate auditory driving or whether driving responses represent a phenomena peculiar to the visual system itself. The latter point is supported by the fact that maximal photic driving occurs at frequencies nearer to the range of alpha activity (8 - 12 Hz) which is strongly associated with activity in the visual system. Since auditory driving was not detected it could not be determined whether peripheral activation -- respiration changes, arousal levels, body movement, and so on, are capable of

enhancing such effects.

It may be stated with some certainty then, that auditory 'driving' effects are not dependent upon the use of naturalistic stimuli in a laboratory setting (eg., drumming sounds as opposed to repetitive clicks or tones). It was noted however, that there may be profound differences between rhythmic stimulation as it is normally encountered in the environment and as it is presented in a laboratory setting, particularly in the case of rhythmic drumming where the additional stimulation from the vibration of the drum may have a large effect.

As well, it was apparent that although the laboratory environment can be adapted in order to present a specific, "immediate" environment for the subject there are other aspects of psychophysiological recording, such as having subjects restrict their movements, avoid blinking, or to be overly conscious of their eye movements and so on, which may be restrictive in the sense of preventing subjects from experiencing behavioural changes that can occur under normal circumstances.

Regarding the concept of EEG entrainment or "driving" itself, it may also be important to examine more closely the nature of oscillating systems in the brain and what role such systems would have in information processing mechanisms. As noted earlier some have criticized the notion of "partially coupled oscillators" within the brain as an explanation for entrainment phenomena even in the case of observed photic

driving responses. Spekrijse (1966) notes that there is a greater dependency of response amplitude on stimulus amplitude than would be expected in the case of synchronization of external stimuli with self-oscillating brain systems. Furthermore, it seems maladaptive for brain 'circuits' to respond readily to entrainment by external stimuli since this kind of resonance in the nervous system could be conceivably damaging or disruptive to normal brain function in certain situations. For example, stroboscopic stimulation is capable of producing seizures in epileptics and such entrainment must be checked in a normally functioning nervous system in order to prevent such instances of 'runaway' synchronization of brain systems. Accordingly, there has been an increasing interest in the role of 'chaotic' behaviour in physiological systems containing circular connections, feedback loops and so on (Garfinkel, 1983).

One speculation on how physiological processes may in fact differ in the case of repetitive auditory stimulation versus repetitive visual stimulation, is that rhythmic sounds may be processed in a different manner than rhythmic light as a result of brain systems organizing sounds temporally and visual input spatially. In other words, sound is organized in terms of temporal patterns, whereas, visual input is organized in terms of spatial patterns occurring in discrete time intervals (although visual information is usually perceived to be occurring in a time ordered sequence as well). Certain sounds,

as in the case of language, have "meaning" to the individual because of the specific temporal arrangements of those sounds. The resultant 'chunking' of this incoming information due to perceptual processing may result in the temporal aspects of auditory input being selectively transformed in a way that may prevent auditory entrainment from occurring. Further studies of the effects of repetitive sounds on the body need to address this aspect of sound perception in more detail before considering brain processes involved.

Given the necessity for incoming auditory information to be organized in terms of its temporal relationships, it may be unreasonable, on theoretical grounds, to assume the same electrical patterns of activity to be manifested in the brain during repetitive auditory stimulation as are during repetitive visual stimulation. It remains to be seen, then, if sensory driven brain rhythms can be achieved in the auditory system in the same manner as in photic driving phenomena.

Recommendations for further research

This study was conducted as a pilot study in order to examine some of the psychophysiological phenomena reported in previous studies on the effects of rhythmic auditory stimulation on the human nervous system. Although, the examination of EEG entrainment was not conclusive in itself, many interesting aspects of responses to musical sounds became apparent over the duration of the study and warrant further examination of relationships that may exist between sounds encountered in the environment and their effects upon the body. The following recommendations are made with regard to further research in this area.

(i) Studies investigating the effects of strong rhythmic sounds, such as ceremonial drumming, should take into account the effects of somesthetic stimulation from vibrational sources of stimulation. It should be noted that 'entrainment' of neurons in the somatosensory cortex of unanaesthetized monkeys has been observed using high-frequency (30 to 40 Hz) mechanical vibration applied to the contralateral hand (Mountcastle et al., 1969). Vibrations are usually considered as "noise" which must be eliminated from the recording environment but in this case such vibrations may constitute an important environmental stimulus with measureable effects upon the body. An examination of these effects may help to interpret some of the effects that certain

sounds are found to have on behaviour.

➤ (ii) It seems apparent from this study that the successful examination of the physiological changes that are expected to occur during ritualistic ceremonies involving pronounced physical stimulation of the body would most successfully be studied "in the field". Improved telemetry techniques may eventually allow such studies to take place and this would greatly increase both knowledge of physiological changes as they occur in such circumstances and indicate steps that may be taken in order to improve laboratory studies of similar responses.

(iii) In the case of gross physiological changes that may be induced by external stimulation of the body it has yet to be determined the extent to which behavioural states of individuals may enhance or augment such changes. The concept of "hyperarousal" in behavioural phenomena such as those mentioned in this study requires closer examination in order to understand the role of central nervous system effects in mediating altered states of awareness or "consciousness" during such phenomena.

APPENDIX A : SCHEMATIC DIAGRAM OF AUDITORY ENVELOPE DETECTOR.

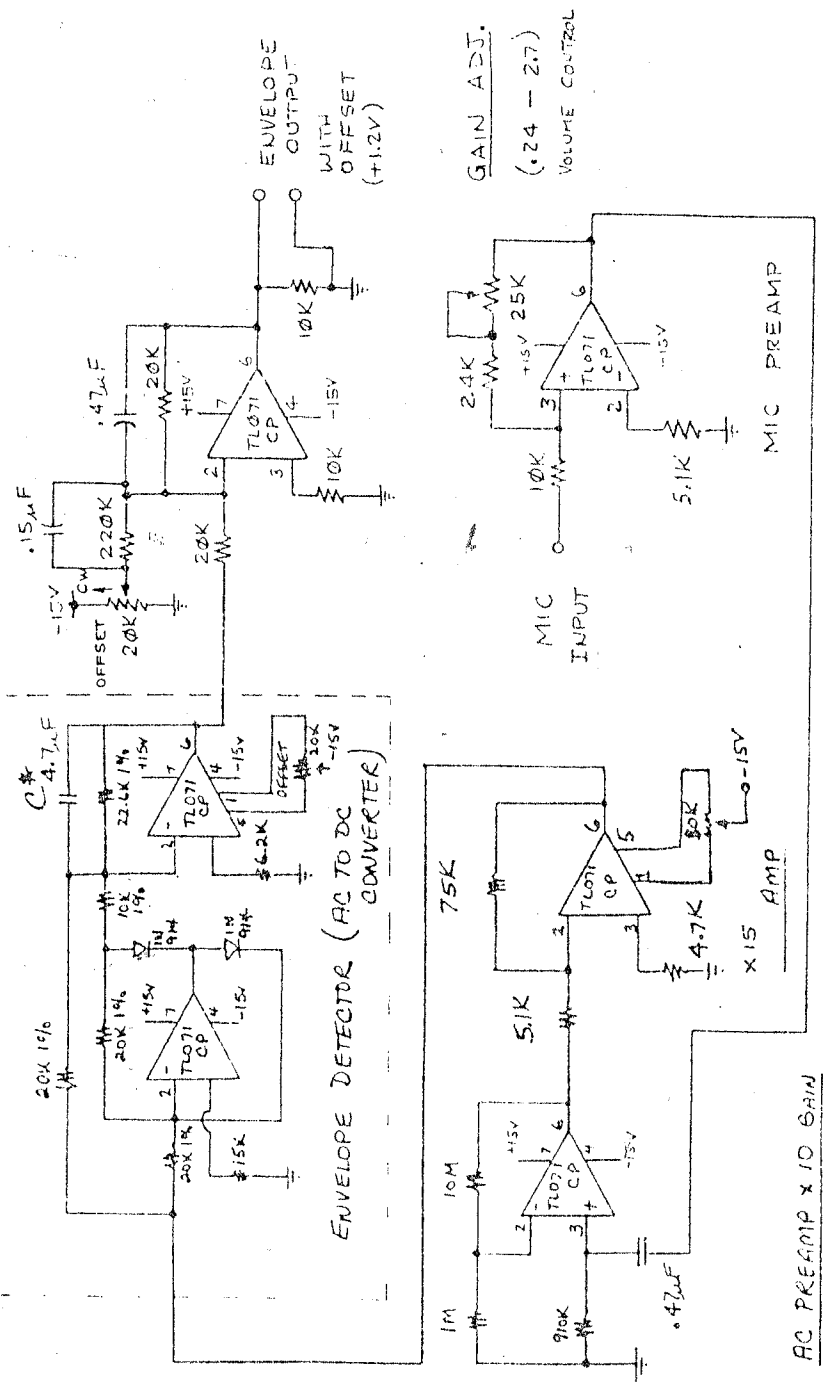

C*: VALUE CHOSEN TO GIVE DESIRED ENVELOPE TIME CONSTANT.

FUNCTION:- INPUT A FROM MICROPHONE (SONY ECM-16) IS AMPLIFIED 25X, AND AC/DC CONVERTER PRODUCES A TIME FUNCTION OF THE AMPLITUDE ENVELOPE. THE OUTPUT ENVELOPE IS A SERIES

SFLW PSYCHOLOGY
AUDIO ENVELOPE AMPLIFIER
CM DAVIS - BABY CRIES
H.F. GARRET, RENS

APPENDIX B : PLOTS OF EEG DATA DURING AUDITORY STIMULATION

EEG DURING AUDITORY STIMULATION AT A RATE OF 3.4 BEATS/SECOND.

(SUBJECT: G. S.)

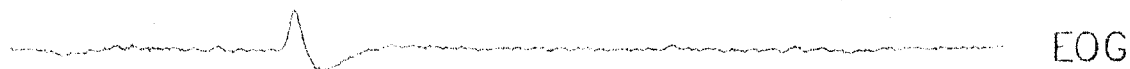
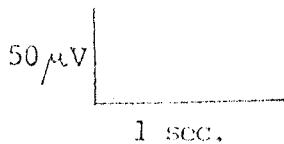
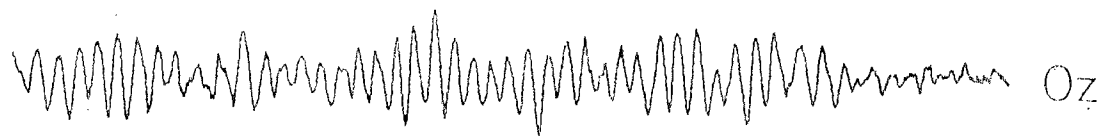
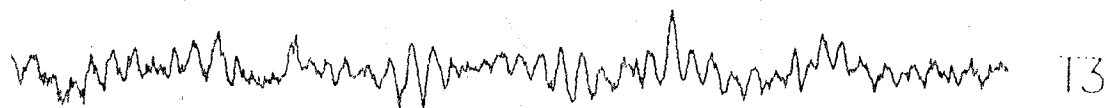
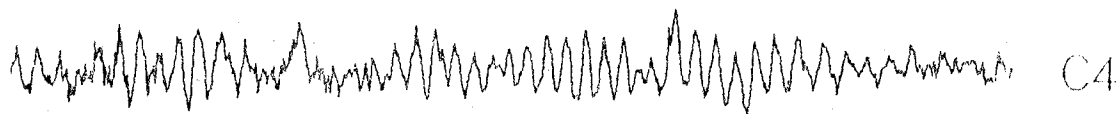
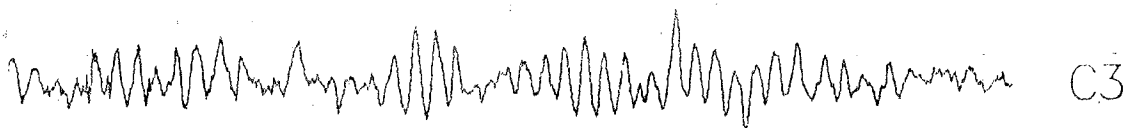

EEG DURING AUDITORY STIMULATION AT A RATE OF 9.0 BEATS/SECOND.

(SUBJECT: G. S.)

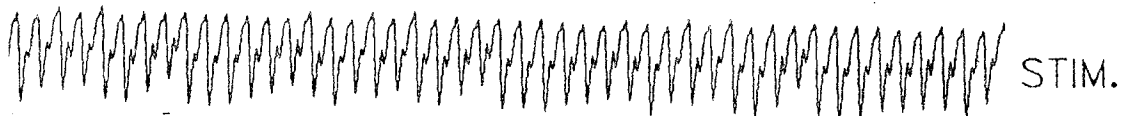
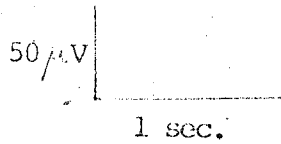
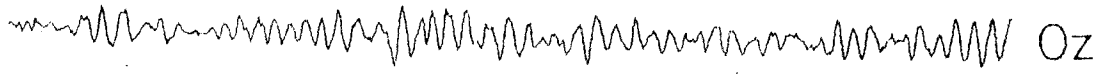

EEG DURING AUDITORY STIMULATION AT A RATE OF 3.4 BEATS/SECOND.

(SUBJECT: D. W.)

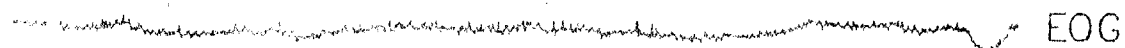
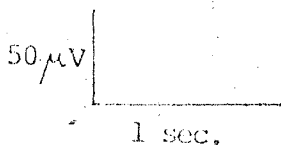

EEG DURING AUDITORY STIMULATION AT A RATE OF 9.0 BEATS/SECOND.

(SUBJECT: D. W.)

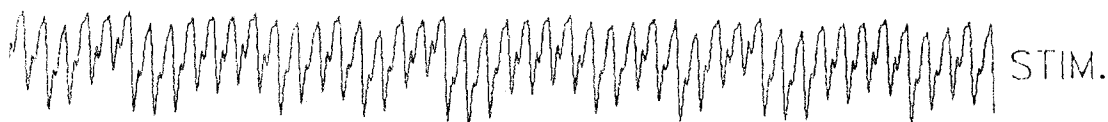
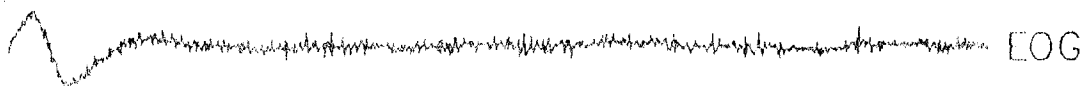
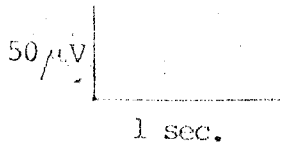
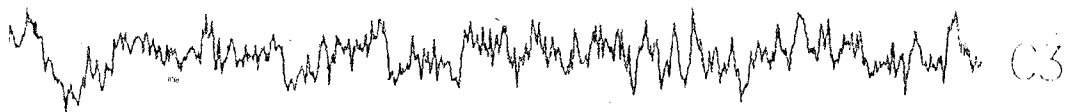

APPENDIX C : PLOTS OF EEG DATA DURING PHOTIC STIMULATION

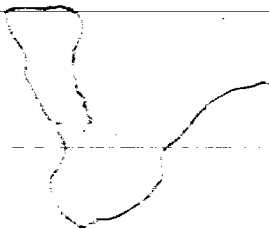
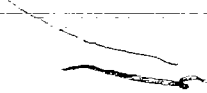

EEG DURING PHOTIC STIMULATION AT A RATE OF 5.0 FLASHES/SECOND.

(SUBJECT: G. S.)

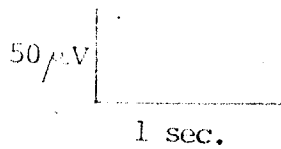
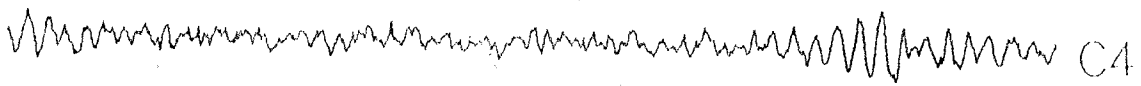

EOG

EEG DURING PHOTIC STIMULATION AT A RATE OF 10.0 FLASHES/SECOND.

(SUBJECT: G. S.)

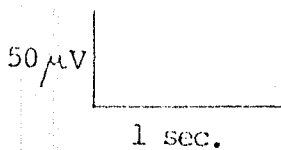
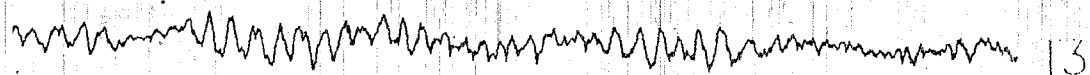
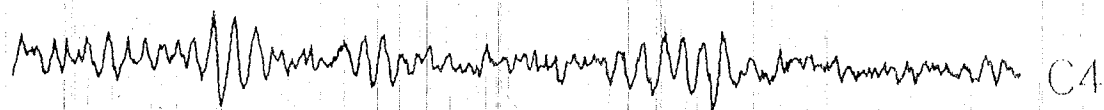

EEG DURING PHOTIC STIMULATION AT A RATE OF 5.0 FLASHES/SECOND.

(SUBJECT: D. W.)

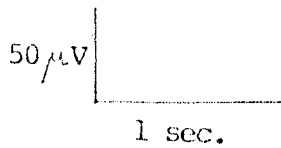
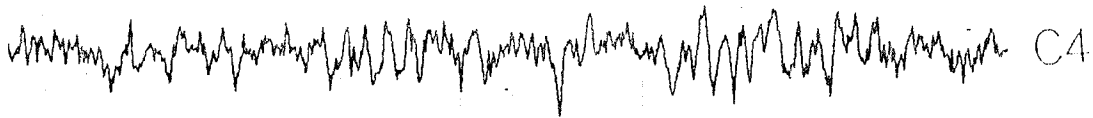

EEG DURING PHOTIC STIMULATION AT A RATE OF 10.0 FLASHES/SECOND.

(SUBJECT: D. W.)



50 μ V

1 sec.

EOG

APPENDIX D : PLOTS OF RECTIFIED EMG DURING AUDITORY STIMULATION

RECTIFIED EMG FOR LEFT AND RIGHT FOREARM PLACEMENTS. SUBJECT
LISTENING TO RHYTHMIC SOUND. (SUBJECT: N. H.)

RIGHT ARM



25 μ V

1 sec

LEFT ARM



RECTIFIED EMG FOR LEFT AND RIGHT FOREARM PLACEMENTS. SUBJECT
TAPPING TO RHYTHMIC SOUND. (SUBJECT: N. H.)

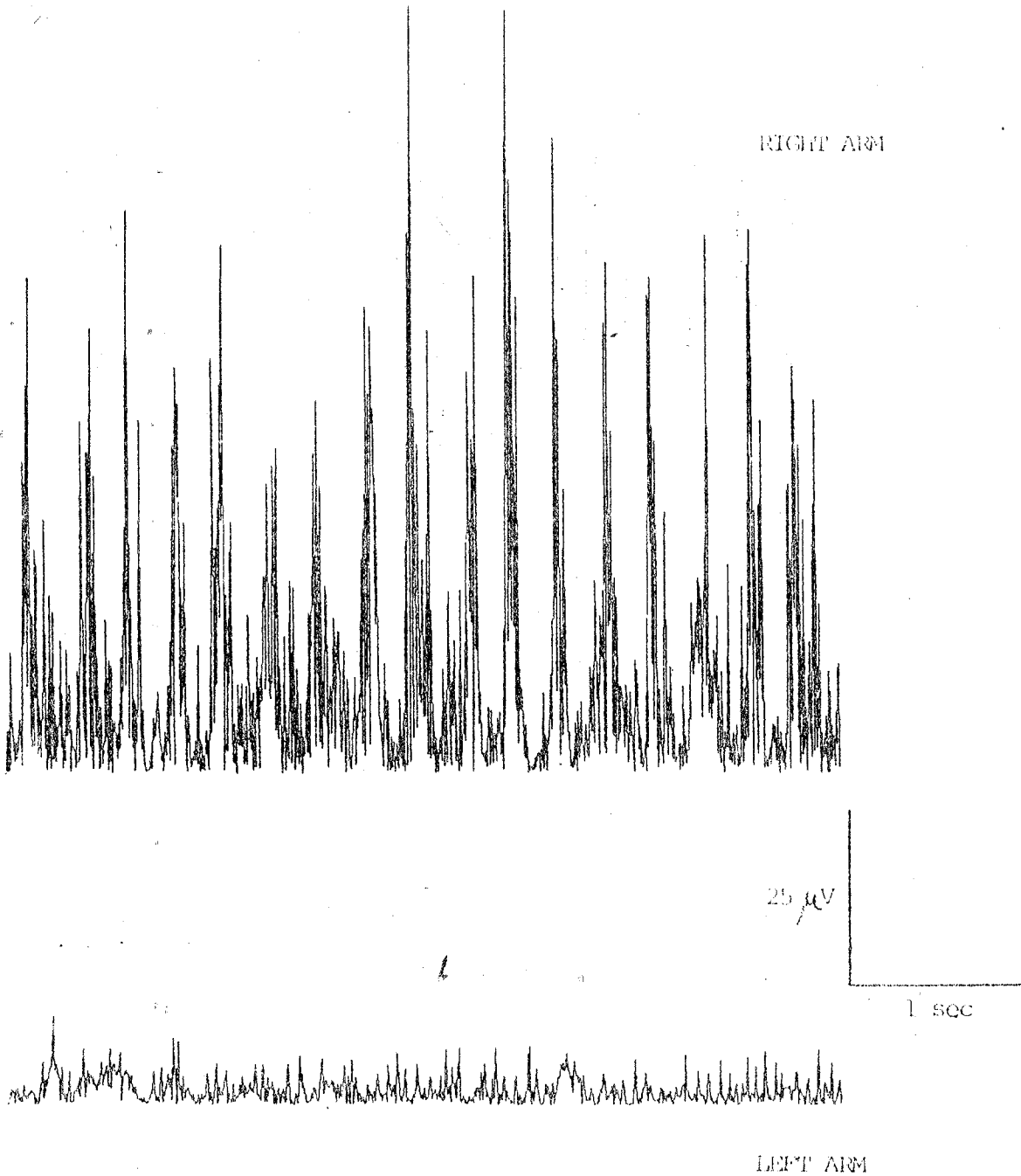

RECTIFIED EMG FOR LEFT AND RIGHT FOREARM PLACEMENTS. SUBJECT
LISTENING TO RHYTHMIC SOUND. (SUBJECT: C. B.)

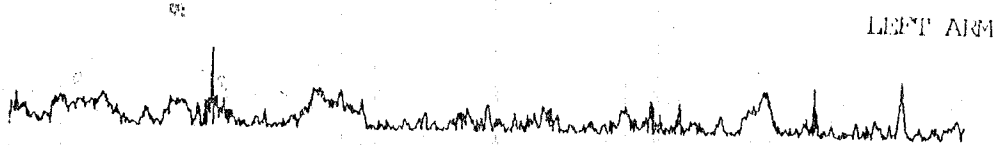
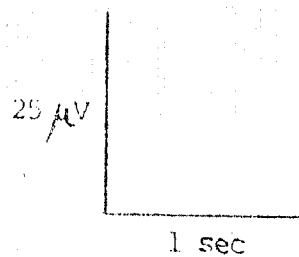
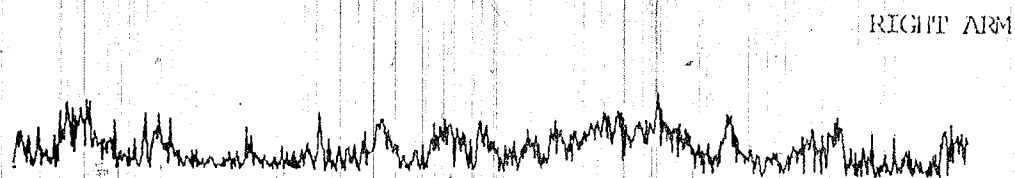

RECTIFIED EMG FOR LEFT AND RIGHT FOREARM PLACEMENTS. SUBJECT
TAPPING TO RHYTHMIC SOUND. (SUBJECT: C. B.)

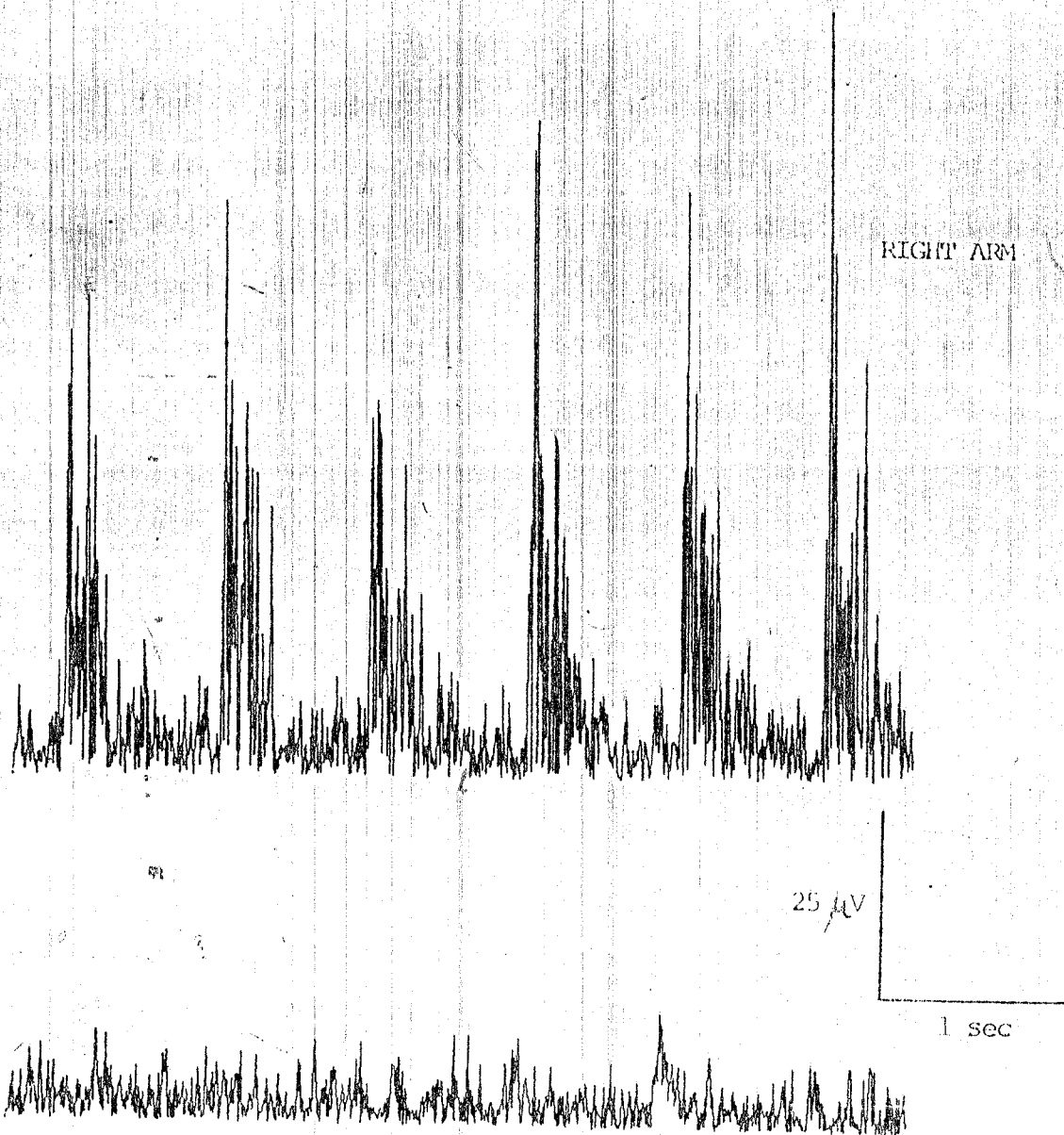

REFERENCE NOTES

1. The term "driving" refers here to the general phenomenon of induced rhythms or the augmentation of existing rhythms in the EEG by repetitive sensory stimulation. Driving responses have been reported in humans in the visual (Adrian & Matthews, 1934; Walter & Walter, 1949) auditory (Neher, 1961) and somesthetic (Mountcastle et al., 1969; Namerow, Scwabassi, & Enns, 1974) sensory modalities.

2. The term "steady state" refers to the condition where, in the case of a repetitive stimulus such as a flickering light source, the interstimulus interval is decreased to the point where there is no longer a one-to-one correspondence between a given stimulus and the response to that stimulus. In this domain of evoked potential research the data are typically presented in the form of plots of frequency components versus stimulus frequency i.e., the response is no longer analyzed in the time domain (see Regan, 1972, p.75 for review).

3. Photic driving was not attained in rats under various levels of barbiturate and non-barbiturate anaesthesia. It was concluded that RAS suppression may inhibit driving responses (Cheyne, 1981).

4. It may be noted here that there exists a condition known as "musicogenic epilepsy" (seizures induced by musical stimuli) however, its occurrence is very rare and the sounds capable of inducing seizures in such individuals are not necessarily rhythmic in nature (Scott, 1977).

5. It should be noted that certain problems may arise in the attempt to distinguish musical rhythms from non-musical rhythms in order to study the effects of 'repetitive' sounds on the brain and nervous system without considering the social - cultural content engendered by such sounds. Given a definition of music as any form of organized sound that may have meaning to an individual it would therefore be impossible to present a rhythmic sound stimulus devoid of any "meaning" to the subject and not resultant in further cognitive processing.

Speculations on the relationship between music and language (see in particular, Pribram, 1982) may provide some insights into the way in which the brain may process sounds such as to distinguish musical from non-musical sounds. Specifically, it is stated that it is necessary to take into consideration the meaning engendered by musical stimuli as distinct from the meaning engendered by language, particularly language that is considered "poetic" in nature. Interestingly, it is noted that repetition and variations on what is expected to be repeated (pragmatic processing) seem to be fundamental to the perception of both music and poetic language, even though music may be devoid of meaning in the 'referential' sense (semantic processing) as in the case of poetic language. Pribram speculates further on different brain structures that may be responsible for these two types (semantic and pragmatic) of organization and processing of music and language suggesting that different brain areas may be involved.

6. In the perception of tones, frequency is often grouped according to such Gestalt principles as "similarity" and "good continuation". For example, if tones from two different frequency ranges are played in rapid succession the listener will perceive them as two parallel streams (stream segregation) indicating that the role of unconscious inference in perception of complex sounds may cause temporal and even spatial distortions of the original sound source (Deutsch, 1982). It has been proposed that rhythmic perception may involve similar principles of organization as well (Beauvillain, 1983).

7. Single frequency components in a discrete Fourier transform (FFT) are relative in magnitude to the entire magnitude or 'power' within the spectrum bounded by the limits of the function $F(t)$ from 0 to $1/2 f_s$ ($1/2 f_s$ being the Nyquist frequency or $1/2$ the sampling frequency f_s). Raw EEG data was smoothed prior to FFT analysis with a filter window of 3 points which effectively reduced the sampling frequency to 66.66 Hz yielding FFT spectra with a maximum frequency of 33.33 Hz.

Magnitude measures of FFT frequency components can be evaluated in various ways, for example, in relation to the entire spectrum or in relation to a frequency band in the spectrum (eg., 8 - 12 Hz for alpha). Since the FFT program used only provided printed output of FFT results it was not possible to perform further computerized analysis of the FFT's (eg. area under the total spectrum). Consequently, histograms were produced by averaging the magnitudes from five consecutive 3.8

second epochs of data (selected from points throughout the stimulus condition) which had been subjected to FFT analysis.

3.8 second epochs provided a spectral resolution (step size) of 0.26 Hz which allowed easier identification of frequency components for this purpose.

REFERENCES

- Adrian, E. D. & Matthews, B. H. C. (1934) The Berger rhythm; potential changes from the occipital lobes in man. Brain 57 p. 355 - 385.
- Anderson, P. & Eccles, J. (1962) Inhibitory Phasing of Neuronal Discharge Nature 196 pp. 645 - 647.
- Ayres, B. (1973) Effects of Infant Carrying Practices on Rhythm in Music. Ethos 1(4) pp. 387-404.
- Bartlett, N. R. & Bartlett, S. C. (1959) Synchronization of a motor response with an anticipated sensory event. Psyc. Rev. 66 pp. 203 - 218.
- Beauvillain, C. (1983) Auditory perception of dissonant polyrhythms. Percept. and Psychophysics 34 pp. 585 - 592.
- Bever, T. G. & Chiarello, R. J. (1974) Cerebral Dominance in Musicians and Non-musicians. Science 185 pp. 537-539.
- Beyerstein, B. (1984) The Myth of Alpha Consciousness. The Sceptical Inquirer (in press).
- Bickford, R. G.; Jacobson, J. L.; Thane, D. & Cody, R. (1964) Nature of average evoked potentials to sound and other stimuli in man. Ann. N. Y. Acad. Sci. 112 pp. 204 - 218.
- Birbaumer, N. (1977) Operant Enhancement of EEG-Theta Activity In J. Beatty & H. Legewie (eds.) Biofeedback and Behavior N. Y. Plenum Press. pp.135-148
- Borchgrevink, H. M. (1982) Prosody and Musical Rhythm are controlled by the speech hemisphere. In Clynes, M. (ed.) Music, Mind, and Brain. The Neuropsychology of Music Plenum Press, New York pp. 151-158.
- Celesia, G. G. (1976) Organization of Auditory Cortical Areas in Man Brain 99 pp. 403 - 414.
- Chapple, E. D. (1970) Culture and Biological Man. Explorations in Behavioral Anthropology Holt, Rinehart, & Winston, New York.
- Cheyne, D. O. (1981) Photic Driving of the Electroencephalogram and Functional Asymmetry in the Rat. Unpublished honours thesis, University of Waterloo, Waterloo.

Clynes, M. & Walker, J. (1982) Neurobiologic Functions of Rhythm, Time, and Pulse in Music. In Clynes, M. (ed.) Music, Mind, and Brain. The Neuropsychology of Music Plenum Press, New York pp. 171-216.

Cohen, S. N., Syndulko, K., Tourtellotte, W. W., & Potvin, A. R. (1980) Critical Frequency of Photic Driving in the Diagnosis of Multiple Sclerosis. Arch. Neurol. 37, pp. 80 - 83.

Creutzfeldt, O. & Houchin, J. (1974) Neuronal Basis of EEG-Waves. In Handbook of Electroencephalography and Clinical Neurophysiology Vol. 2(C) A. Remond (Ed.) Elsevier, Amsterdam.

Creutzfeldt, O. (1978) The Neocortical Link: Thoughts on the Generality of Structure and Function of the Neocortex. In Brazier, M. A. B. & H. Petsche (Eds.) Architectonics of the Cerebral Cortex Raven Press, New York.

De Lange, H. (1958) Research into the dynamic nature of the human fovea-cortex systems with intermittent and modulated light. J. opt. Soc. Amer. 48 pp. 777 - 784.

Deutsch, D. (1982) Organizational Processes in Music. In Clynes, M. (ed.) Music, Mind, and Brain. The Neuropsychology of Music Plenum Press, New York pp. 118 - 135.

Elul, R. (1972) The Genesis of the EEG Int. Rev. Neurobiol. 15 pp. 227 - 272.

Erlmann, V. (1982) Trance and Music in the Hausa Boori Spirit Possession Cult in Niger Ethnomusicology 26 pp. 49-58

Fraisse, P. (1982) Rhythm and Tempo. In The Psychology of Music D. Deutsch (ed.) Academic Press, New York. pp. 149-180.

Gabrielsson, A. (1982) Perception and Performance of Musical Rhythm. In Clynes, M. (ed.) Music, Mind, and Brain. The Neuropsychology of Music Plenum Press, New York pp. 159-170.

Garfinkel, A. (1983) A mathematics for physiology. Am. J. Physiol. 245 pp. R455 - R466.

Gavalas, R. J.; Walter, D. O.; Homer, J. & Adey, W. R. (1970) Effects of low-level, low-frequency electrical fields on EEG and behavior in Macaca Nemestrina. Brain Res. 18 pp. 491 - 501.

Goldman, D. (1952) The effect of rhythmic auditory stimulation on the human EEG. Electroenceph. clin. Neurophysiol. 4, p. 370

Goodman, F. (1972) Speaking in Tongues: A cross-cultural study of glossalalia University of Chicago Press, Chicago.

Golubeva, E. A. (1972) The Driving Reaction as a Method of Study in Differential Psychophysiology. In Biological Bases of Individual Behaviour, Nebylitsyn, V. D. & Gray, J. A. (Eds.), Academic Press, New York.

Hamel, B.; Bourne, J. R., Ward, J. W. & Teschen P. E. (1978) Quantitative Assessment of Photic Driving in Renal Failure. Electroenceph. clin. Neurophysiol. 45 pp. 719 - 730.

Handel, S. & Lawson, G. R. (1983) The contextual nature of rhythmic interpretation. Percept. & Psychophysics 34 pp. 103 - 120.

Huxley, A. Heaven and Hell. London, Chatto & Windus, 1956.

Jilek, W. G. (1982) Indian Healing: Shamanic Ceremonialism in the Pacific Northwest Today. Hancock House Pub. Ltd. Surrey.

Jones, A. M. (1954) African rhythm Africa 24, p. 26

Kasamatsu, A. & Hirai, T. (1966) An electroencephalographic study on the Zen meditation (Zazen). Folia Psychiatrica et Neurologica Japonica 20 p. 315

Laderman, C. (1983) Trances that Heal: Rites, Rituals, and Brain Chemicals. Science Digest July, 1983, pp.80-83;104.

Lawrence, A. F. & Adey, W. R. (1982) Non-linear wave mechanisms in interactions between excitable tissue and electromagnetic fields. Neurol. Res. 4 pp. 115 - 153.

Lex, B. (1979) The Neurobiology of Ritual Trance. In d'Aquili, E. G.; Laughlin, C. D. & McManus, J. (eds.) The Spectrum of Ritual. A Biogenetic Structural Analysis Columbia University Press, New York.

Lindsley, D. B., Bouden, J. W. & Magoun, H. W. (1949) Effects upon the EEG of acute injury to the brain stem activating system. Electroenceph. clin. Neurophysiol. 1, p. 475

Lopes da Silva, F. H.; Hoeks, H.; Smits, H. & Zetterberg, L. H. (1974) Model of brain rhythmic activity. Kybernetik 15 p. 27 - 37.

- Lopes da Silva, F. H. & Storm van Leeuwen W. (1978) The Cortical Alpha Rhythm in Dog: The Depth and Surface Profile of Phase. In Brazier, M. A. B. & H. Petsche (Eds.) Architectonics of the Cerebral Cortex Raven Press, New York.
- Loyd-Smith, D. L. & Henderson L. R. (1951) Epileptic patients showing susceptibility to photic stimulation alone. Electroenceph. clin. Neurophysiol. 3 p. 378.
- Lundin, R. W. (1967) An Objective Psychology of Music Ronald Press, New York.
- Mazziotta, J. C.; Phelps, M. E.; Carson, R. E. & Kuhl, D. E. (1982) Tomographic Mapping of human cerebral metabolism: Auditory Stimulation. Arch. Neurol. 32 pp.921-937.
- Møller, A. R. (1983) Auditory Physiology Academic Press, New York.
- Morrison, R. S. & Dempsey, E. W. (1942) A study of thalamo - cortical relations. Am. J. Physiol. 135, p. 281
- Moruzzi G. & Magoun H. W. (1949) Brain stem reticular formation and activation of the EEG. Electroenceph. clin. Neurophysiol. 1, pp. 455 - 473.
- Mountcastle, V. B.; Talbot, W. H.; Sakata, H. & Hyvarinen, J. (1969) Cortical Neuronal Mechanisms in Flutter-Vibration Studied in Monkeys. Periodicity and Frequency Discrimination. J. Neurophysiol. 32 pp. 452 - 484.
- Namerow, N. S., Sclabassi, R. J. & Enns, N. F. (1974) Somatosensory responses to stimulus trains: normative data. Electroenceph. clin. Neurophysiol. 37, p. 11
- Naquet, R. (1974) Activation and Provocation Methods in Clinical Neurophysiology. In Handbook of Electroencephalography and Clinical Neurophysiology Vol 3 (D) A. Remond (Ed.), Elsevier, Amsterdam.
- Neher, A. (1961) Auditory driving observed with scalp electrodes in normal subjects. Electroenceph. clin. Neurophysiol. 13, p. 449 - 451.
- Neher, A. (1962) A Physiological Explanation of Unusual Behaviour in Ceremonies involving Drums. Human Biology 34, p. 151 - 160.
- Plutchik, R. (1966) Frequency Analysis of Electroencephalographic Rhythms in Humans Exposed to High Intensity Intermittent Auditory Inputs. Perceptual and Motor Skills 23, p. 955

- Pribram, K. H. (1982) Brain mechanism in music: Prologemena for a theory of the meaning of meaning. In Clynes, M. (ed.) Music, Mind, and Brain. The Neuropsychology of Music Plenum Press, New York pp.21-36.
- Prince, R. (1968) Can the EEG be used in the study of Possession States? In Trance and Possession States, Prince, R. (Ed). R. M. Bucke Memorial Society, Montreal.
- Radocy, R. E. & Boyle, J. D. (1979) Psychological Foundations of Musical Behavior Charles C. Thomas, Springfield.
- Ramani, V.; Torres, F.; & Luewenson, R. (1984) Critical Driving Frequency of Photic Driving in the Diagnosis of Multiple Sclerosis Arch. Neurol. 41 pp. 752 - 755.
- Regan, D. (1972) Evoked Potentials in Psychology, Sensory Physiology, and Clinical Medicine. Chapman and Hall, London.
- Robinson, G. M. & Solomon, D. J. (1974) Rhythm is processed by the speech hemisphere. J. Exp. Psych. 102 pp. 508-511.
- Rodenburg, M., Verweij, C. & Van den Brink, G. (1972) Analysis of evoked responses in man elicited by sinusoidally modulated noise, Audiology 11, p. 283
- Rogers, L. J. (1976) Human EEG Response to Certain Rhythmic Patterned Auditory Stimuli, with Possible Relations to EEG Lateral Asymmetry Measures and EEG Correlates of Chanting, Ph.D. Dissertation, University of California, Los Angeles.
- Rogers, L. J. & Walter D. O. (1981) Methods for Finding Single Generators, with application to Auditory Driving of the Human EEG by Complex Stimuli. Journal of Neuroscience Methods 4, p. 256
- Roland, P. E.; Skinhoj, E. Lassen, N. A. (1981) Focal Activations of human cerebral cortex during auditory discrimination. J. Neurophysiol. 45 pp.1139-1151.
- Romani, G. L.; Williamson, S. H. & Kaufman, L. (1982) Tonotopic Organization in the Human Auditory Cortex Science 216 pp. 1339 - 1340.
- Rouget, G. (1980) La musique et la transe: Esquisse d'une théorie générale des relations de la musique et de la possession Paris, Gallimard.
- Sachs, M. (1984) Neural Coding of Complex Sounds: Speech Ann. Rev. Physiol. 46 pp. 261 - 273.
- Sargent, W. (1964) Battle for the Mind. Pan Books, London.

- Scott, D. F. (1977) Musicogenic epilepsy. In M. Critchley & Henson, R. A. (eds.) Music and the Brain. Studies in the Neurology of Music Heinmann Medical Books Ltd., London.
- Spekreijse, H. (1966) Analysis of EEG Responses in Man Evoked by Sine Wave Modulated Light. These Sciences Amsterdam.
- Steriade, M.; Stoica, I. & Stoica, E. (1962) Certain Physiological Conditions Enhancing Potentials Evoked in Man by Rhythmic Photic Stimulation. Electroenceph. clin. Neurophysiol. 14 p. 572.
- Steriade, M. (1970) Ascending Regulating Cerebral Systems. Int. Rev. Neurobiol. 12 pp. 87 - 144.
- Storm van Leeuwen, W.; Lopes da Silva, F. H.; & Kamp, A. (Eds.) (1975) Evoked Responses. In Handbook of Electroencephalography and Clinical Neurophysiology Vol. 8(a) A. Remond (Ed. in chief) Elsevier, Amsterdam.
- Townshend, R. E.; Lubin, A. & Naitoh, P. (1975) Stabilization of Alpha Frequency by Sinusoidally Modulated Light. Electroenceph. clin. Neurophysiol. 39 pp. 515 - 518.
- Ulett, G. A. (1953) Preliminary observations of convulsive and subconvulsive treatments induced by intermittent photic stimulation. Amer. J. Psychiat. 109, p. 741.
- Van der Tweel, L. H. & Verduyn Lunel, H. F. E. (1965) Human Visual Responses to Sinusoidally Modulated Light. Electroenceph. clin. Neurophysiol. 18 pp. 587 - 598.
- Walter, V. J. & Walter W. G. (1949) The central effects of rhythmic sensory stimulation. Electroenceph. clin. Neurophysiol. 1, p. 57 - 86.
- Womack, S. (1980) I haven't stopped drinking I just changed my brand. J. of Drug Issues 10 pp. 301-310.
- Yeston, M. (1976) The Stratification of Musical Rhythm Yale University Press, New Haven.